

SANYO

No. ※ 2120B

LC7462M**Infrared Remote Control Transmitter IC****Preliminary****Functions**

- 32 ⊕ 3 function keys
- 8-bit custom codes
- Operating supply voltage range $V_{DD} = 1.8$ to 3.6 V
- Supply current at the standby mode $I_{DD} = 1$ μ A or less
- Double-pressable operation keys (no priority given)
- Oscillator built in (ceramic resonator: connected externally)

Features

- Two selections of custom code (8 bits)
(SEL pin-selectable ... option)
- Since the custom code is set internally, no external diode is required.
- Since double-press operation provides no priority, the number of external parts can be reduced.

Package Dimensions

unit : mm

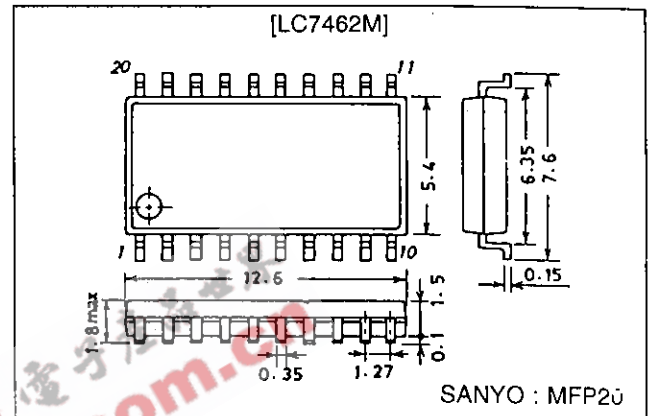
3036B-MFP20**Specifications****Absolute Maximum Ratings at $T_a = 25^\circ\text{C}$**

Parameter	Symbol	Conditions	Ratings	Unit
Maximum supply voltage	$V_{DD \text{ max}}$	V_{DD}	$V_{SS}-0.3$ to $+5.5$	V
Input voltage	V_{IN}	Each input pin	$V_{SS}-0.3$ to $V_{DD}+0.3$	V
Output voltage	V_{OUT}	Each output pin	$V_{SS}-0.3$ to $V_{DD}+0.3$	V
Output current	I_{OUT}	OUT	-35	mA
Allowable power dissipation	$P_d \text{ max}$	$T_a \leq 85^\circ\text{C}$	150	mW
Operating temperature	T_{opr}		-40 to +85	$^\circ\text{C}$
Storage temperature	T_{stg}		-50 to +125	$^\circ\text{C}$

Allowable Operating Conditions at $T_a = 25^\circ\text{C}$

Parameter	Symbol	Conditions	min	typ	max	Unit
Supply voltage	V_{DD}	$V_{DD} = f_{osc} = 455$ kHz	1.8	3.0	3.6	V
Input high-level voltage	V_{IH}	K_{j0} to K_{j3} , SEL	$0.7V_{DD}$		V_{DD}	V
Input low-level voltage	V_{IL}	K_{j0} to K_{j3} , SEL	V_{SS}		$0.3V_{DD}$	V
Oscillation frequency	f_{osc}		400	455	500	kHz

LC7462M

Electrical Characteristics at Ta = 25°C, V_{DD} = 3.0 V

Parameter	Symbol	Conditions	min	typ	max	Unit
Operating supply current	I _{DD}	V _{DD} = Key ON, output: no load			1	mA
Quiescent supply current	I _{DS}	V _{DD} = All keys OFF, OSC stop			1	μA
Output high-level current	I _{OH1}	OUT = V _{DD} = 1.8 V, V _{OH} = 1.0 V		-8		mA
	I _{OH2}	OUT = V _{DD} = 3.0 V, V _{OH} = 1.0 V		-25		mA
Display output current	I _{OL1}	IND = V _{DD} = 1.8 V, V _{OH} = 1.0 V		2		mA
	I _{OL2}	IND = V _{DD} = 3.0 V, V _{OH} = 1.0 V		5		mA
Output high-level voltage	V _{OH}	K _O 0 to K _O 7 = I _{OH} = -0.1 mA			0.3	V
Output low-level voltage	V _{OL}	OUT = I _{OL} = 0.1 mA			0.3	V
Output OFF-state leakage current	I _{OFF}	K _O 0 to K _O 7, IND			1	μA
Input high-level current	I _{IH}	SEL = V _{IN} = V _{DD}			1	μA
Input low-level current	I _{IL}	SEL = V _{IN} = V _{SS}	-1			μA
Input floating voltage	V _{IF}	K _I 0 to K _I 3			0.1V _{DD}	V
Input pull-down resistance	R _{IN}	K _I 0 to K _I 3	75	100	125	kΩ

Pin Assignment

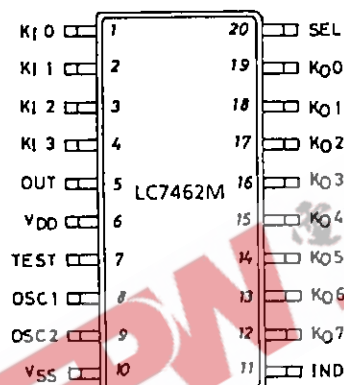

Top view

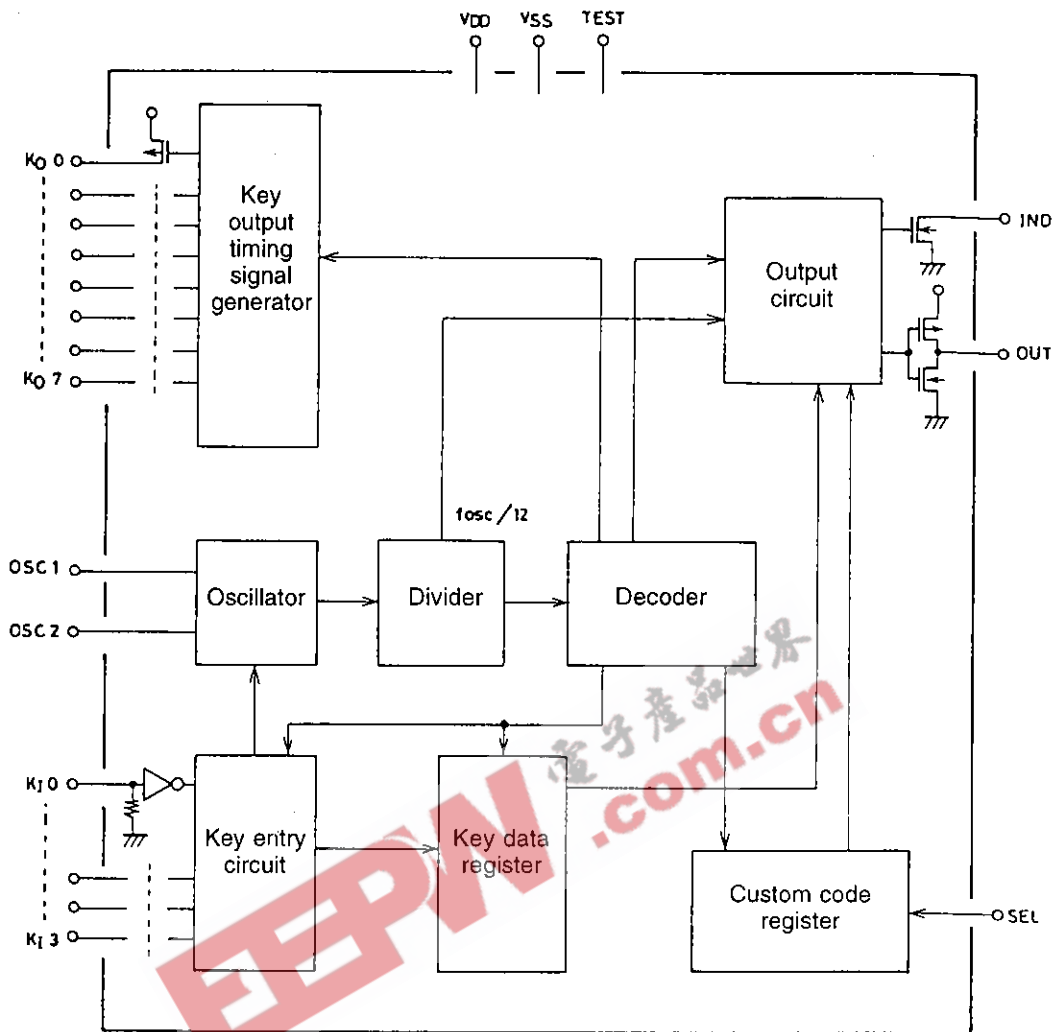

LC7462M

Block Diagram

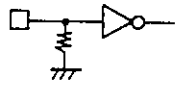
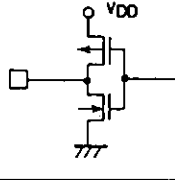
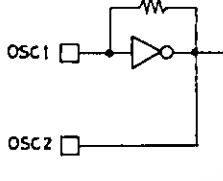

LC7462M

Pin Description

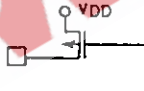
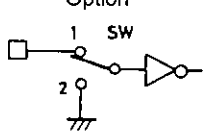
Pin Name	Pin No.	Input/Output	Equivalent Circuit	Pin Function
V _{DD} , V _{SS}	6, 10			Power supply pins: V _{SS} = GND
K _j 0 to K _j 3	1 to 4	Input		Key return signal entry pins
OUT	5	Output		Output pin for transmit LED drive
TEST	7	Input		LSI test pin Normally set to high-level or brought to open state
OSC1 OSC2	8 9	Input/output		Input/output pins for ceramic resonator-used oscillation
IND	11	Output		Output pin for transmit indicator LED drive
K ₀ 0 to K ₀ 7	12 to 19	Output		Key scan timing signal output pins
SEL	20	Input		Either of the two shown below may be selected by option. (1) SW position 1 ON Two selections of custom code by SEL "H" or "L" (2) SW position 2 ON SEL pin: NC (No Connection)

General Description of Function

1. Oscillator

Since a self-bias type amplifier of CMOS inverter is contained, an oscillator can be formed by connecting a ceramic resonator.

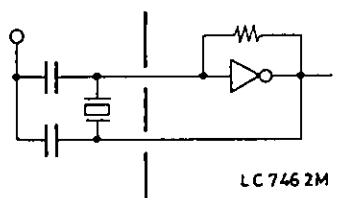

To minimize power dissipation, the oscillator stops oscillating except when key operation is performed.

LC7462M

2. Key entry

Key entry pins K_I0 to K_I3 and timing signal output pins K_O0 to K_O7 provide a key matrix of $4 \times 8 = 32$.

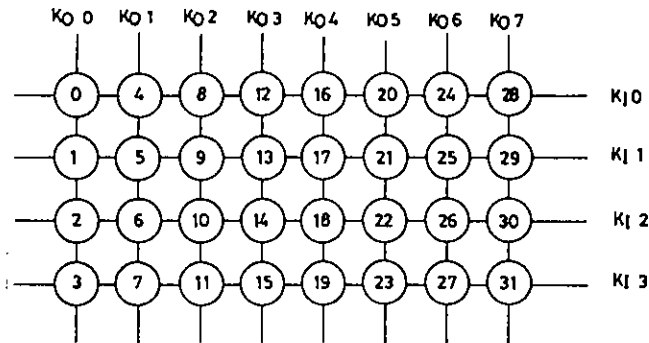

Multi-press of key No. 20 and one of key Nos. 21, 22, 23 may be done, with no priority given in key entry. When the two keys are kept pressed, a series of pulses will be output according to each key entry. If multi-press of keys which are not allowed multi-press is done, no output will be delivered.

3. Data organization

Data consists of 32 bits in all: 8 bits of custom code, 8 bits of key data, and their inverted codes.

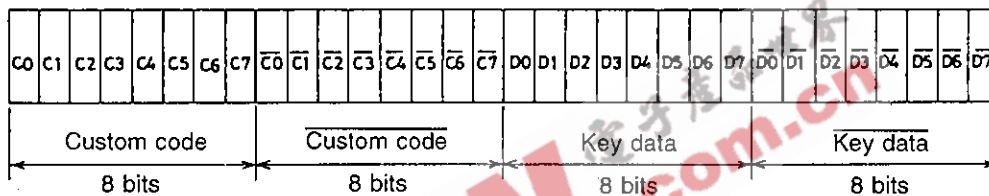

(a) Custom code

The custom code, which consists of 8 bits (C_0 to C_7) in all, is used to distinguish between receiving sets.

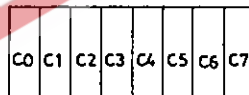

C_0 to C_7 are fixed by the internal mask ROM (impossible to fix externally). Two selections of custom code may be made externally by option (SEL pin-selectable).

Custom code option

	Option 1	Option 2
Custom code to be set internally	2 kinds	1 kind
Function of SEL pin	Two selections of custom code by SEL "H" or "L"	NC (No Connection)

LC7462M

(b) Key data

KEY No.	D ₀	D ₁	D ₂	D ₃	D ₄	D ₅	D ₆	d ₇
0	0	0	0	0	0	0	0	0
1	1	0	0	0	0	0	0	0
2	0	1	0	0	0	0	0	0
3	1	1	0	0	0	0	0	0
4	0	0	1	0	0	0	0	0
5	1	0	1	0	0	0	0	0
⋮	⋮	⋮	⋮	⋮	⋮	⋮	⋮	⋮
28	0	0	1	1	1	0	0	0
29	1	0	1	1	1	0	0	0
30	0	1	1	1	1	0	0	0
31	1	1	1	1	1	0	0	0

Multi-press

KEY No.	D ₀	D ₁	D ₂	D ₃	D ₄	D ₅	D ₆	D ₇
20, 21	1	0	1	0	1	1	0	0
20, 22	0	1	1	0	1	1	0	0
20, 23	1	1	1	0	1	1	0	0

• D₆, D₇ may be preset to "0", "1" beforehand (mask option).

When multi-press of key No. 20 and one of key Nos. 21, 22, 23 is done, multi-bit D₅ will be set to "1", with no priority given in key entry.

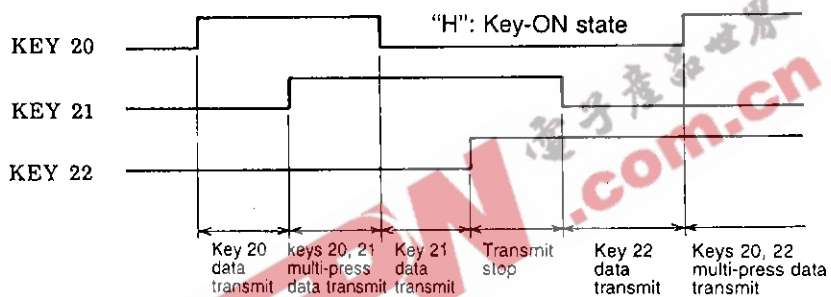

LC7462M

4. Transmit waveforms

The period of time shown below is for $f_{OSC} = 455 \text{ kHz}$.

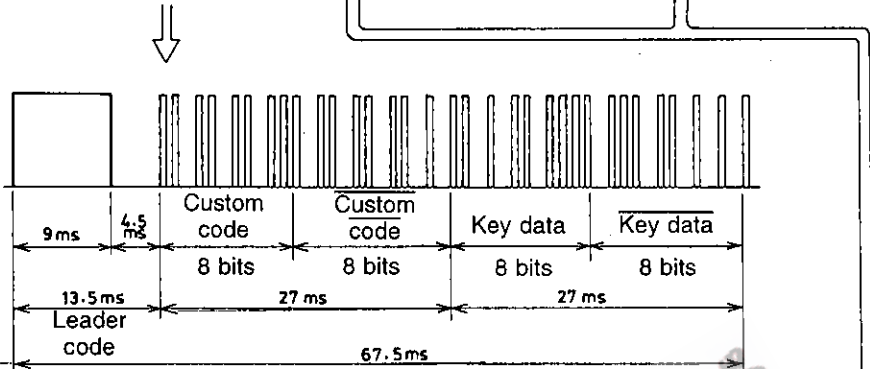
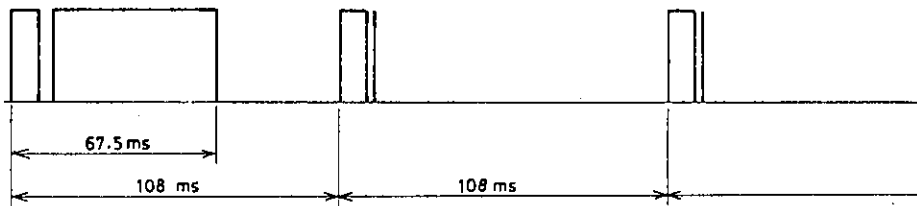

• First time

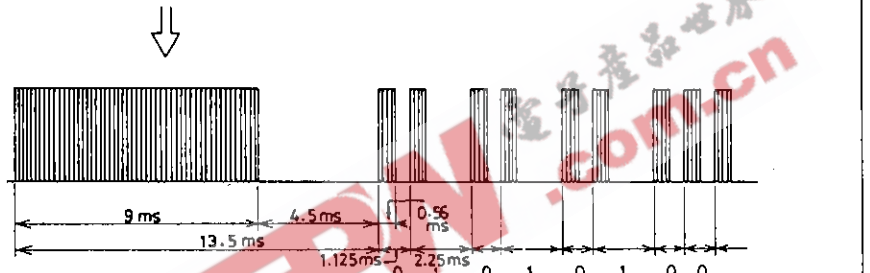

• Second time onward (Transmission is available only when key entry continues.)

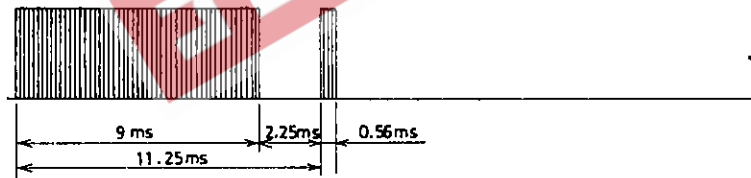

• Carrier waveform

