



No. 4474B

LC7940ND, LC7941ND

Dot-matrix LCD Drivers

Overview

The LC7940ND and LC7941ND are segment driver LSIs for driving large, dot-matrix LCD displays. They read 4-bit parallel or serial input, display data from a controller into an 80-bit latch, and then generate LCD drive signals corresponding to that data.

The LC7940ND and LC7941ND feature mirror-image pin assignments, allowing them to be used together to increase component density. They are designed to be used with the LC7942ND common driver to drive large LCD panels.

Features

- 80 built-in LCD display drive circuits
- 1/8 to 1/128 display duty cycle
- Serial or 4-bit parallel data input
- Chip disable for low power dissipation for large-sized panels
- Bias supply voltages can be supplied externally
- Operating supply voltage and ambient temperature
 - 5V \pm 10% logic supply (V_{DD}) at $T_a = -20$ to $+85^\circ\text{C}$
 - 8 to 20V LCD supply ($V_{DD} - V_{EE}$) at $T_a = -20$ to $+85^\circ\text{C}$
- CMOS process
- 100-pin flat plastic package

Package Dimensions

unit: mm

3180-QIP100D

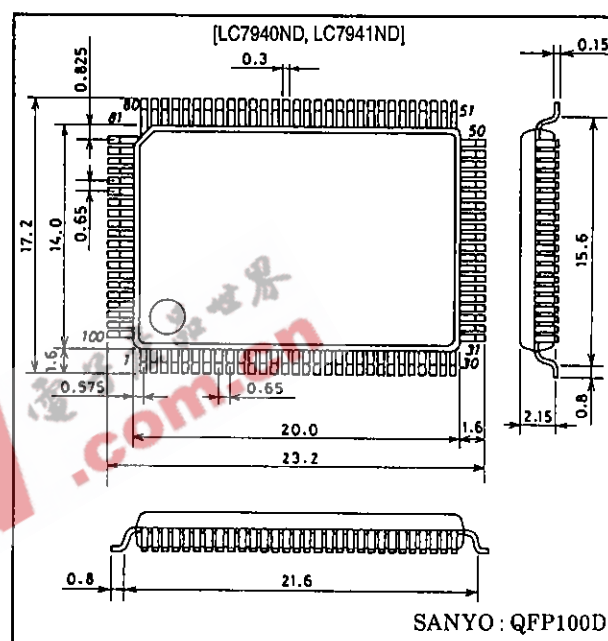

Specifications

Absolute Maximum Ratings at $T_a = 25 \pm 2^\circ\text{C}$, $V_{SS} = 0\text{V}$

Parameter	Symbol	Ratings	Unit
Logic supply voltage	V_{DD} max	-0.3 to +7.0	V
LCD supply voltage. See Note below.	$V_{DD} - V_{EE}$ max	0 to 22	V
Input voltage	V_I max	-0.3 to $V_{DD} + 0.3$	V
Operating temperature range	T_{opr}	-20 to +85	$^\circ\text{C}$
Storage temperature range	T_{slg}	-40 to +125	$^\circ\text{C}$

Note

$$V_{DD} \geq V_1 > V_3 > V_4 > V_{EE}$$

Recommended Operating Conditions at $T_a = -20$ to $+85^\circ\text{C}$, $V_{SS} = 0\text{V}$

Parameter	Symbol	Conditions	Ratings			Unit
			min	typ	max	
Logic supply voltage	V_{DD}		4.5	-	5.5	V
LCD supply voltage	$V_{DD} - V_{EE}$	See Notes 1 and 2.	8	-	20	V
HIGH-level input voltage	V_{IH}	CP, CDI, DI1 to DI3, M, SDI, P/S, DISP OFF and LOAD	$0.8V_{DD}$	-	-	V
LOW-level input voltage	V_{IL}	CP, CDI, DI1 to DI3, M, SDI, P/S, DISP OFF and LOAD	-	-	$0.2V_{DD}$	V
CP shift clock frequency	f_{CP}		-	-	3.3	MHz
CP pulsewidth	t_{WC}		100	-	-	ns
LOAD pulsewidth	t_{WL}		100	-	-	ns
DI x and SDI to CP setup time	t_{SETUP}		80	-	-	ns
DI x and SDI to CP hold time	t_{HOLD}		80	-	-	ns
CP to LOAD time	t_{CL1}		0	-	-	ns
	t_{CL2}		100	-	-	
LOAD to CP time	t_{LC}		100	-	-	ns
CP rise time	t_R		-	-	50	ns
CP fall time	t_F		-	-	50	ns
LOAD rise time	t_{RL}		-	-	50	ns
LOAD fall time	t_{FL}		-	-	50	ns

Notes

- $V_{DD} \geq V_1 > V_3 > V_4 > V_{EE}$
- At turn ON, the LCD supply should be energized after or simultaneously with the logic supply. At turn OFF, the logic supply should be cut after or simultaneously with the LCD supply.

Electrical Characteristics at $T_a = 25 \pm 2^\circ\text{C}$, $V_{SS} = 0\text{V}$, $V_{DD} = 5\text{V} \pm 10\%$

Parameter	Symbol	Conditions	Ratings			Unit
			min	typ	max	
HIGH-level input current	I_{IH}	$V_{IN} = V_{DD}$; LOAD, CP, CDI, P/S, DI1 to DI3, SDI, M, and DISP OFF	-	-	1	μA
LOW-level input current	I_{IL}	$V_{IN} = V_{SS}$; LOAD, CP, CDI, P/S, DI1 to DI3, SDI, M, and DISP OFF	-1	-	-	μA
CDO HIGH-level output voltage	V_{OH}	$I_{OH} = -400 \mu\text{A}$	$V_{DD} - 0.4$	-	-	V
CDO LOW-level output voltage	V_{OL}	$I_{OL} = 400 \mu\text{A}$	-	-	0.4	V
O1 to O80 driver ON resistance	R_{ON}	$V_{DD} - V_{EE} = 18 \text{V}$, $ V_{DE} - V_O = 0.25 \text{V}$. See note.	-	2	4	$\text{k}\Omega$

LC7940ND, LC7941ND

Parameter	Symbol	Conditions	Ratings			Unit
			min	typ	max	
V_{DD} to V_{SS} standby supply current	I_{ST}	$C_{DI} = V_{DD}$, $V_{DD} - V_{EE} = 18\text{ V}$, $f_{CP} = 3.3\text{ MHz}$, no output load ; V_{SS}	-	-	200	μA
V_{DD} to V_{SS} operating supply current	I_{SS}	$V_{DD} - V_{EE} = 18\text{ V}$, $f_{CP} = 3.3\text{ MHz}$, $f_{LOAD} = 5.156\text{ kHz}$, $f_M = 52\text{ Hz}$; V_{SS}	-	-	1.0	mA
V_{DD} to V_{EE} operating supply current	I_{EE}	$V_{DD} - V_{EE} = 18\text{ V}$, $f_{CP} = 3.3\text{ MHz}$, $f_{LOAD} = 5.156\text{ kHz}$, $f_M = 52\text{ Hz}$; V_{EE}	-	-	0.1	mA
CP input capacitance	C_i	$f_{CP} = 3.3\text{ MHz}$; CP	-	5	-	pF

Note

$V_{DE} = V_1$ or V_3 or V_4 or V_{EE} , $V_1 = V_{DD}$, $V_3 = 9/11 \times (V_{DD} - V_{EE})$, $V_4 = 2/11 \times (V_{DD} - V_{EE})$

Switching Characteristics at $T_a = 25 \pm 2^\circ\text{C}$, $V_{SS} = 0\text{V}$, $V_{DD} = 5\text{V} \pm 10\%$

Parameter	Symbol	Conditions	Ratings			Unit
			min	typ	max	
CDO output delay time	t_D	$C_L = 30\text{ pF}$	-	-	200	ns

Switching Characteristics Waveform

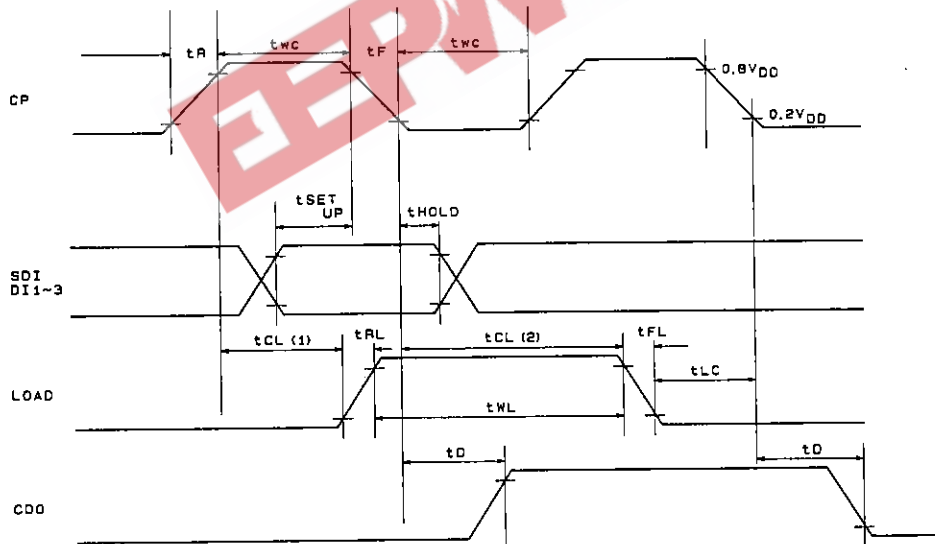

A01857

LC7940ND, LC7941ND

Pin Assignments

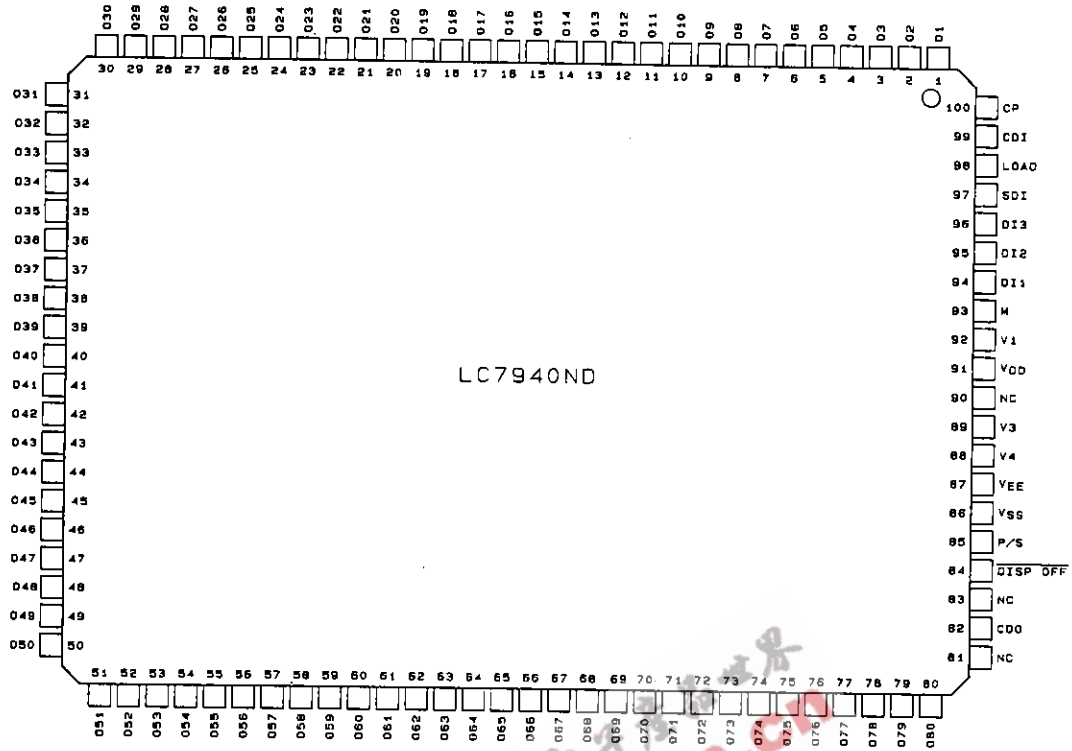

LC7940ND

A01890

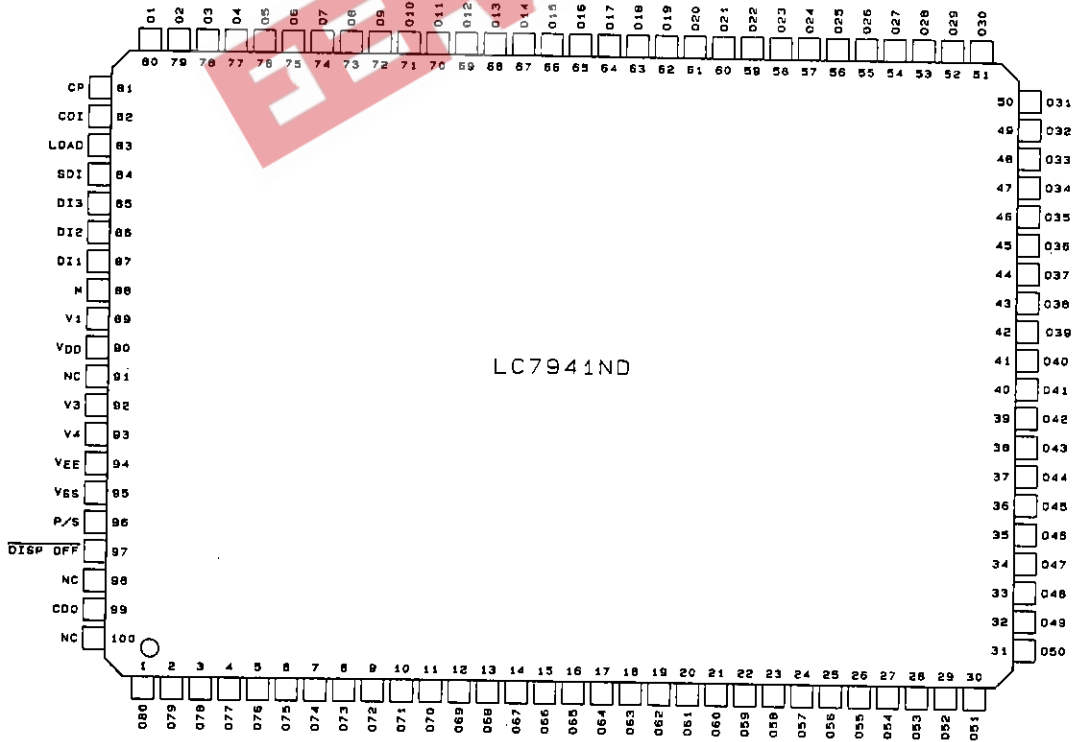

LC7941ND

A01881

Top view

Block Diagram

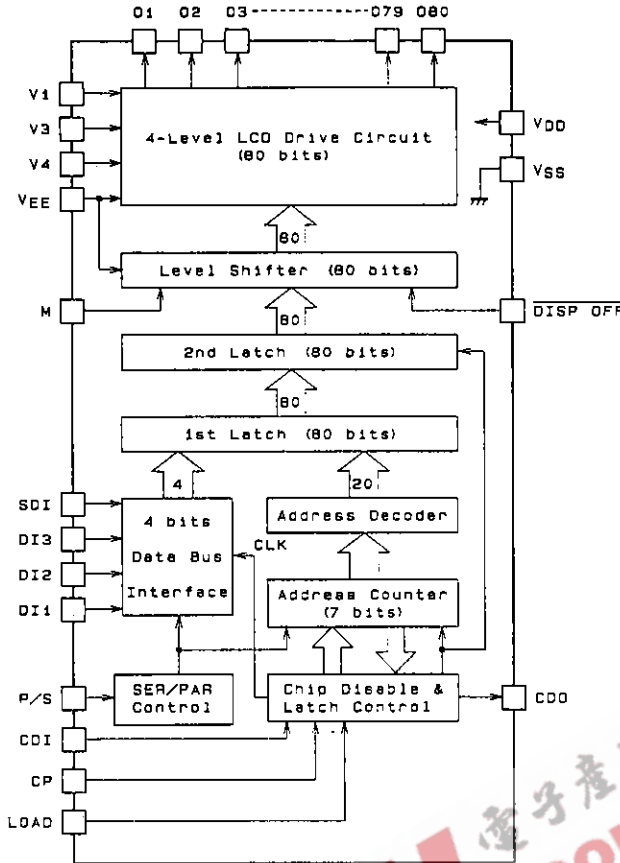

Pin Functions

Pin No.		Symbol	I/O	Function
LC7940ND	LC7941ND			
91	90	VDD	Supply	VDD - VSS is the logic supply. VDD - VEE is the LCD supply.
86	95	VSS		
87	94	VEE		
92	89	V1	Supply	LCD panel drive voltage supplies V1 and VEE are selected levels. V3 and V4 are not-selected levels.
89	92	V3		
88	93	V4		
100	81	CP	I	Display data input clock (falling-edge trigger).
99	82	CDI	I	Chip disable. Data is read in when LOW, and not read in when HIGH.
98	83	LOAD	I	Display data latch clock (falling-edge trigger). On the falling edge, the LCD drive signals set by the display data are output.
97	84	SDI	I	Serial data input.

LC7940ND, LC7941ND

Pin No.		Symbol	I/O	Function																								
LC7940ND	LC7941ND																											
96	85	DI3	I	4-bit parallel data input pins. <table border="1" style="margin-left: 20px;"> <thead> <tr> <th>Data Input</th> <th colspan="3">LCD driver outputs</th> </tr> </thead> <tbody> <tr> <td>SDI</td> <td>O4</td> <td>O8</td> <td rowspan="4" style="text-align: center;">→</td> <td>O80</td> </tr> <tr> <td>DI3</td> <td>O3</td> <td>O7</td> <td>O79</td> </tr> <tr> <td>DI2</td> <td>O2</td> <td>O6</td> <td>O78</td> </tr> <tr> <td>DI1</td> <td>O1</td> <td>O5</td> <td>O77</td> </tr> </tbody> </table>	Data Input	LCD driver outputs			SDI	O4	O8	→	O80	DI3	O3	O7	O79	DI2	O2	O6	O78	DI1	O1	O5	O77			
Data Input	LCD driver outputs																											
SDI	O4	O8			→	O80																						
DI3	O3	O7	O79																									
DI2	O2	O6	O78																									
DI1	O1	O5	O77																									
95	86	DI2																										
94	87	DI1																										
In serial data input mode, DI1 to DI3 should all be tied HIGH or LOW.																												
93	88	M	I	LCD panel drive voltage output alternation control signal.																								
85	96	P/S	I	Data input mode select. 4-bit parallel input when HIGH, and serial input when LOW.																								
82	99	CDO	O	Cascade connection pin for extension segment drivers. Data is read out when HIGH. Goes LOW after data is read out. Connected to the CDI input of the next chip.																								
1 to 80	80 to 1	O1 to O80	O	LCD drive outputs. The output drive level is determined by the display data, M signal and $\overline{\text{DISP OFF}}$ input as shown below. <table border="1" style="margin-left: 20px;"> <thead> <tr> <th>M</th> <th>Q</th> <th>$\overline{\text{DISP OFF}}$</th> <th>Output</th> </tr> </thead> <tbody> <tr> <td>LOW</td> <td>LOW</td> <td>HIGH</td> <td>V_3</td> </tr> <tr> <td>LOW</td> <td>HIGH</td> <td>HIGH</td> <td>V_1</td> </tr> <tr> <td>HIGH</td> <td>LOW</td> <td>HIGH</td> <td>V_4</td> </tr> <tr> <td>HIGH</td> <td>HIGH</td> <td>HIGH</td> <td>V_{EE}</td> </tr> <tr> <td>×</td> <td>×</td> <td>LOW</td> <td>V_1</td> </tr> </tbody> </table>	M	Q	$\overline{\text{DISP OFF}}$	Output	LOW	LOW	HIGH	V_3	LOW	HIGH	HIGH	V_1	HIGH	LOW	HIGH	V_4	HIGH	HIGH	HIGH	V_{EE}	×	×	LOW	V_1
M	Q	$\overline{\text{DISP OFF}}$	Output																									
LOW	LOW	HIGH	V_3																									
LOW	HIGH	HIGH	V_1																									
HIGH	LOW	HIGH	V_4																									
HIGH	HIGH	HIGH	V_{EE}																									
×	×	LOW	V_1																									
Note × = don't care (tied HIGH or LOW)																												
84	97	DISP OFF	I	O1 to O80 output control input pin. When LOW, V_1 is output on the O1 to O80 outputs. See the truth table.																								
81	91	NC	-	No connection.																								
83	98	NC																										
90	100	NC																										

Application Notes

LCD Panel 1

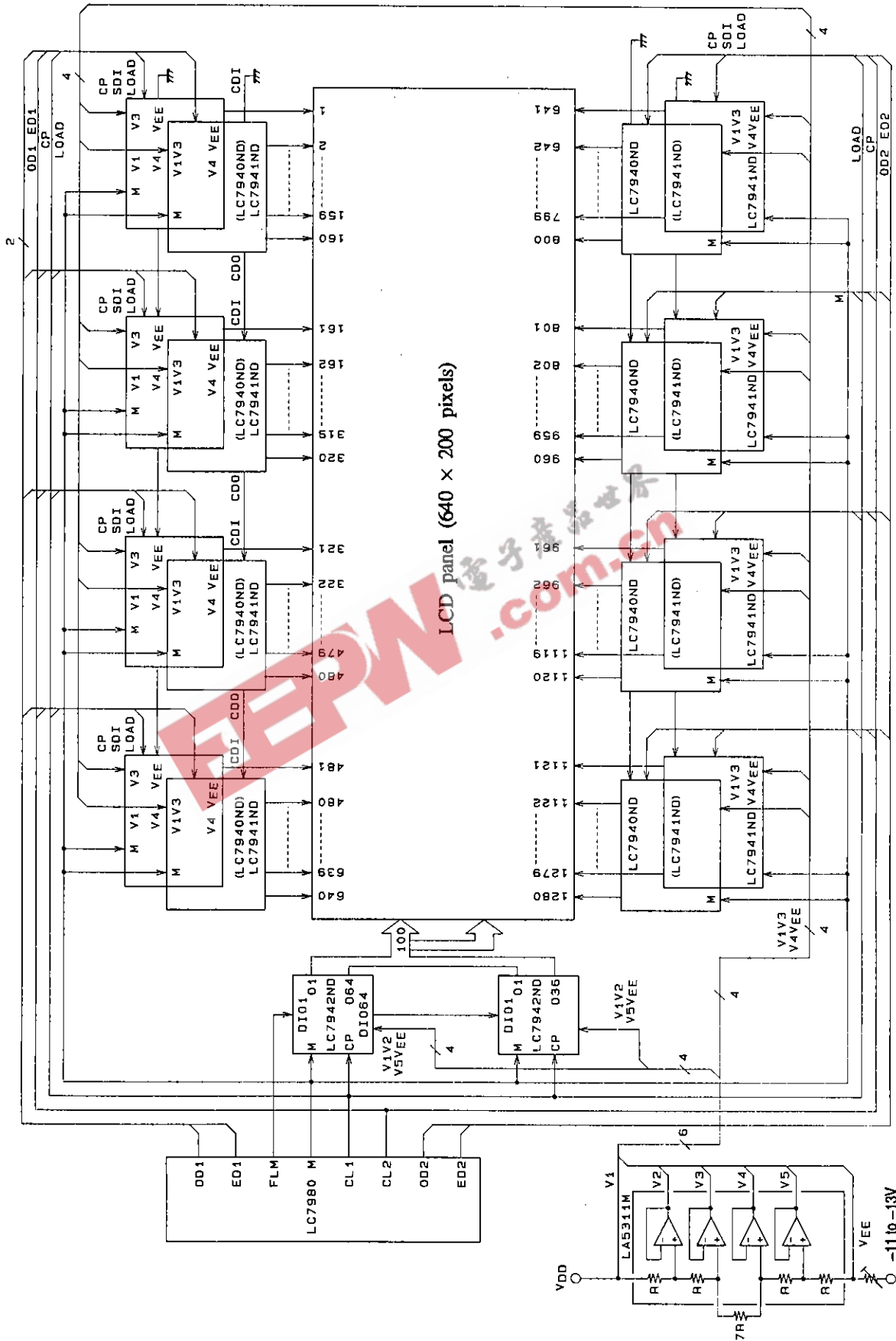

AO1647

LCD Panel 2

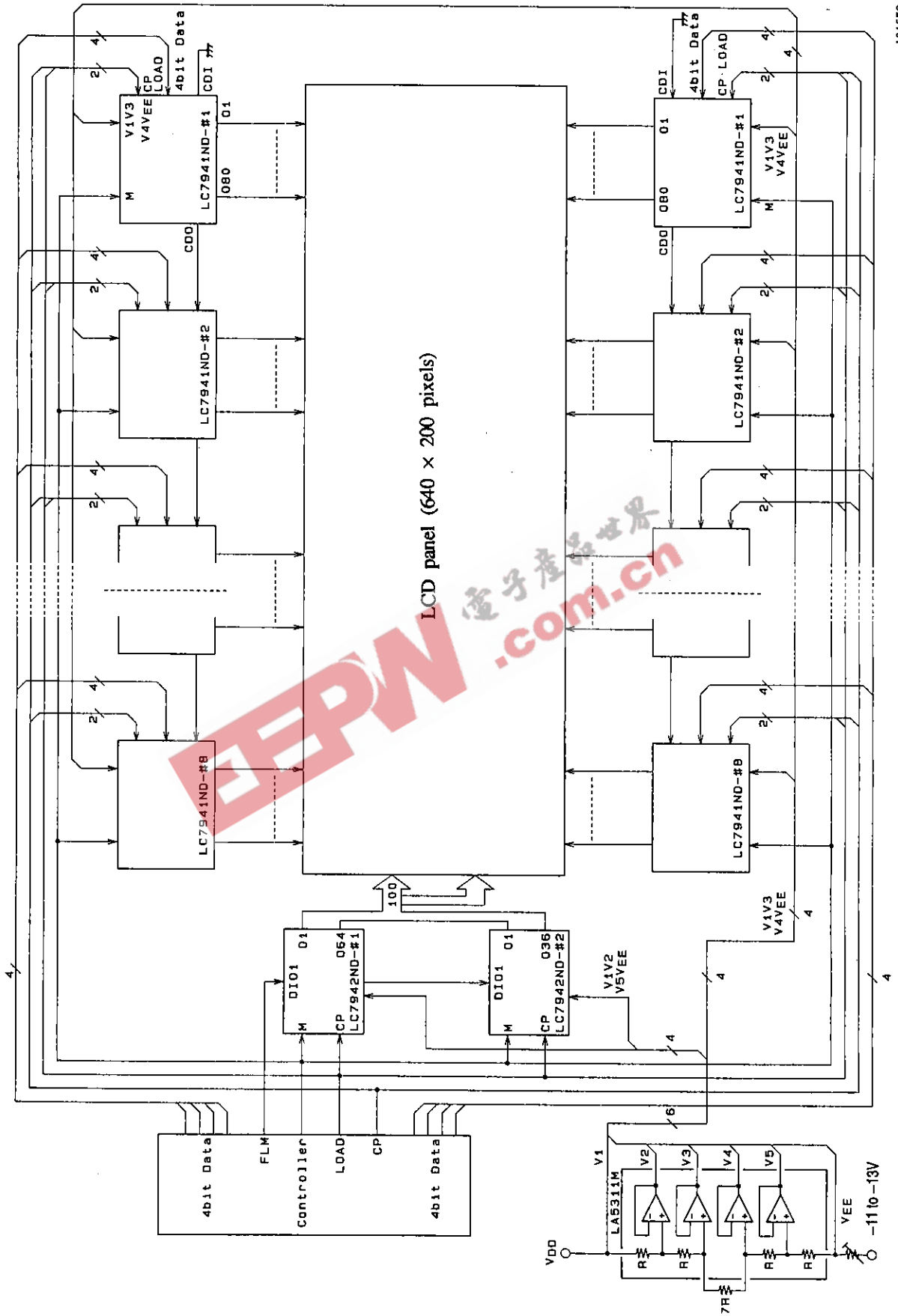

A01652

100 × 240-pixel LCD Panel Application

A 100 × 240-pixel LCD panel requires the following drivers.

- 3 × LC7940ND (or LC7941ND) drivers
- 2 × LC7942ND drivers

An example using 1/100 duty cycle is shown below.

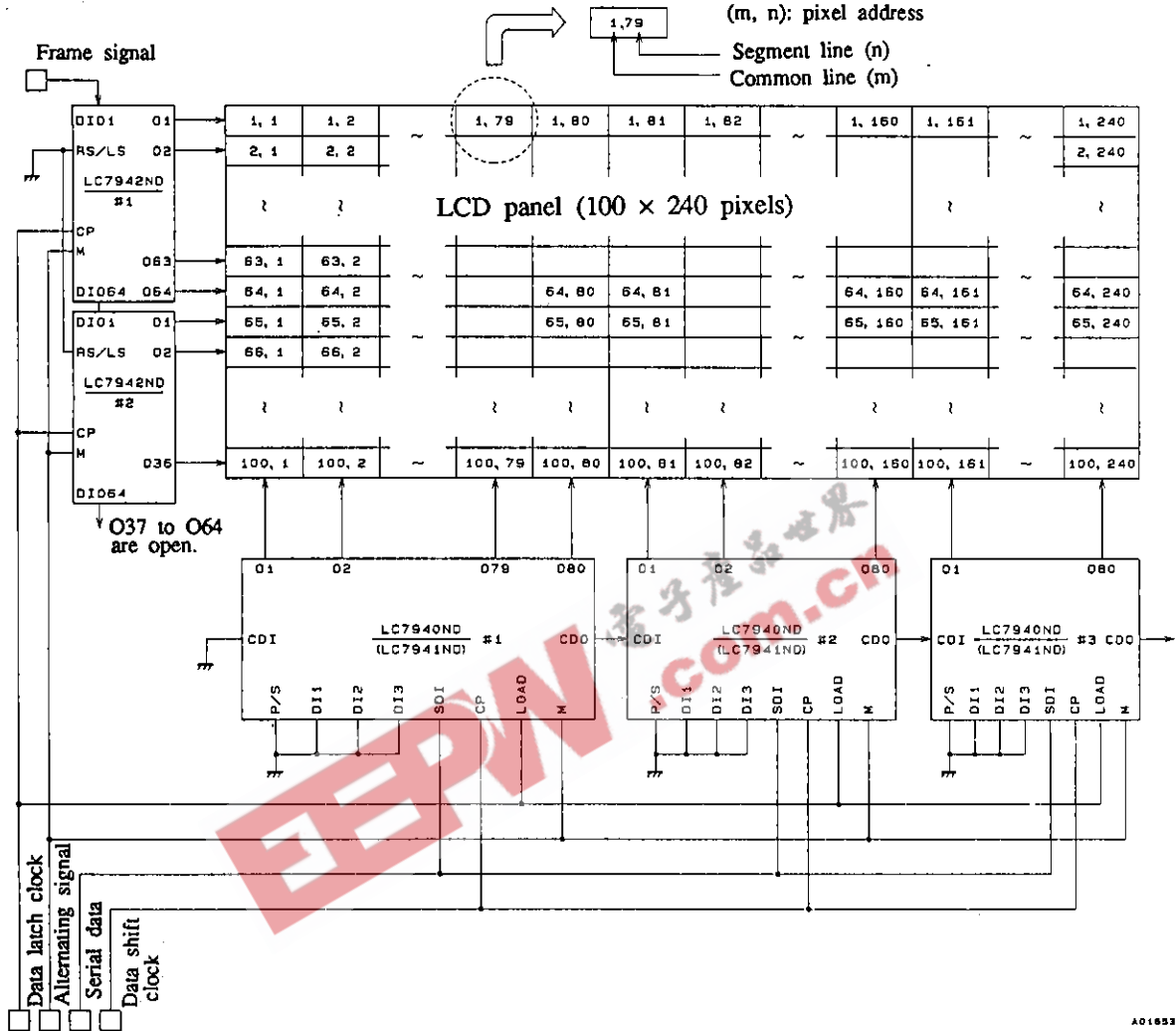

A01693

1. The LC7942ND chips are cascaded by connecting DIO64 on chip 1 to DIO1 on chip 2. For a 100-bit shift register, O37 to O64 on chip 2 are left open.
2. The LC7940ND (or LC7941ND) chips are cascaded by connecting CDO on chip 1 to CDI on chip 2, and

CDO on chip 2 to CDI on chip 3. CDI on chip 1 is tied to GND, and CDO on chip 3 is not used. This configuration allows the input of 240-bit serial data.

100 × 240-pxel LCD Panel Timing Diagram

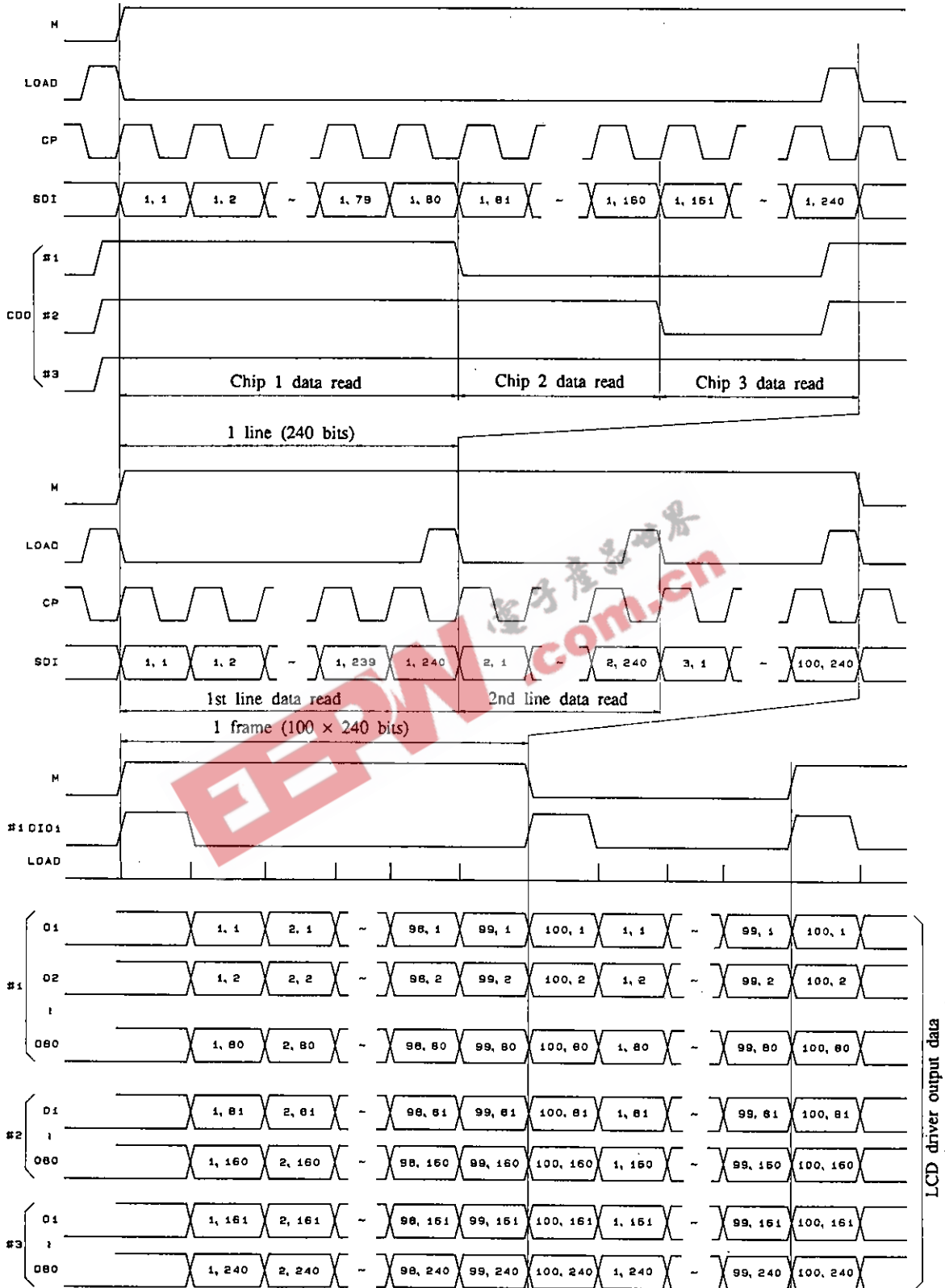

A01654

Segment Data Not Multiples of 4

Example.

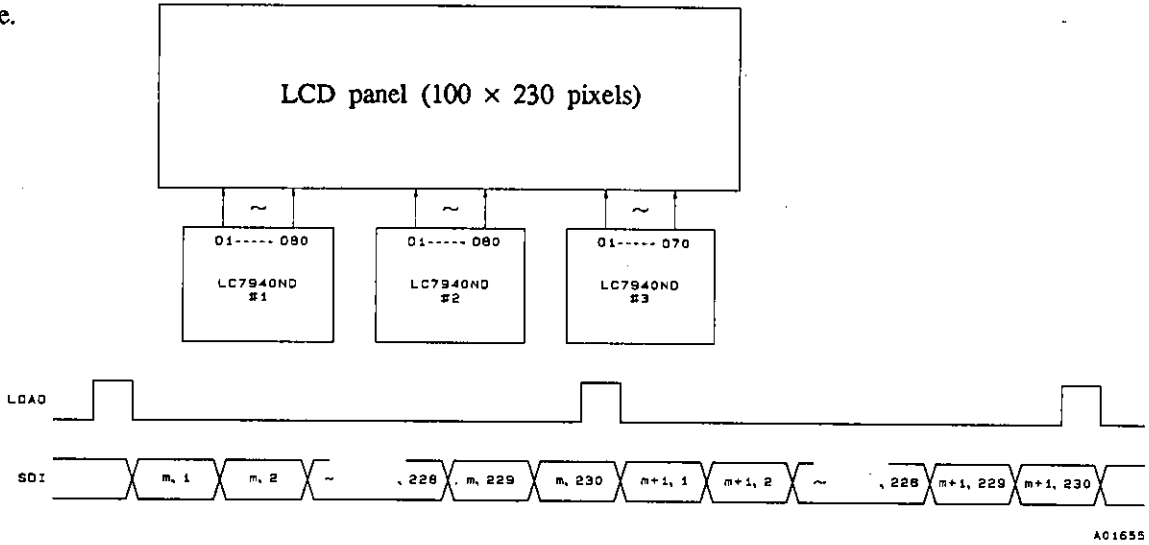

If this timing data is sent, data elements (m, 229), (m, 230), (m+1, 229), (m+1, 230)... will not appear in the output (O69 and O70 on chip 3). This is because the LC7940ND (or LC7941ND) converts serial/parallel data

in 4-bit units, which also decreases power dissipation. For data that is not a multiple of 4, like 230, the following scheme is used.

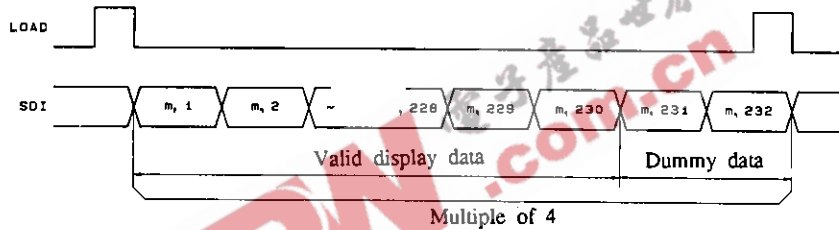

In this case, (m, 231) is output on O71 on chip 3, and (m, 232) on O72 on chip 3. However, these outputs are not connected to the panel and are, therefore, invalid.

- No products described or contained herein are intended for use in surgical implants, life-support systems, aerospace equipment, nuclear power control systems, vehicles, disaster/crime-prevention equipment and the like, the failure of which may directly or indirectly cause injury, death or property loss.
- Anyone purchasing any products described or contained herein for an above-mentioned use shall:
 - ① Accept full responsibility and indemnify and defend SANYO ELECTRIC CO., LTD., its affiliates, subsidiaries and distributors and all their officers and employees, jointly and severally, against any and all claims and litigation and all damages, cost and expenses associated with such use:
 - ② Not impose any responsibility for any fault or negligence which may be cited in any such claim or litigation on SANYO ELECTRIC CO., LTD., its affiliates, subsidiaries and distributors or any of their officers and employees, jointly or severally.
- Information (including circuit diagrams and circuit parameters) herein is for example only; it is not guaranteed for volume production. SANYO believes information herein is accurate and reliable, but no guarantees are made or implied regarding its use or any infringements of intellectual property rights or other rights of third parties.

This catalog provides information as of November, 1995. Specifications and information herein are subject to change without notice.