



LC72722, 72722M, 72722PM

Single-Chip RDS Signal-Processing System LSI



Overview

The LC72722 and LC72722M, LC72722PM are single-chip system ICs that implement the signal processing required by the European Broadcasting Union RDS (Radio Data System) standard and by the US NRSC (National Radio System Committee) RDBS (Radio Broadcast Data System) standard. These ICs include band-pass filter, demodulator, synchronization, and error correction circuits as well as data buffer RAM on chip and perform effective error correction using a soft-decision error correction technique.

Functions

- Band-pass filter: Switched capacitor filter (SCF)
- Demodulator: RDS data clock regeneration and demodulated data reliability information
- Synchronization: Block synchronization detection (with variable backward and forward protection conditions)
- Error correction: Soft-decision/hard-decision error correction
- Buffer RAM: Adequate for 24 blocks of data (about 500 ms) and flag memory
- Data I/O: CCB interface (power on reset)

Features

- Error correction capability improved by soft-decision error correction
- The load on the control microprocessor can be reduced by storing decoded data in the on-chip data buffer RAM.

- Two synchronization detection circuits provide continuous and stable detection of the synchronization timing.
- Data can be read out starting with the backward-protection block data after a synchronization reset.
- Bit slip detection and correction
- Low spurious radiation
- Fully adjustment free
- Operating power-supply voltage: 4.5 to 5.5 V
- Operating temperature: -40 to +85°C
- Package: LC72722 : DIP24S
LC72722M : MFP24S
LC72722PM : MFP24

Package Dimensions

unit: mm

3067A-DIP24S

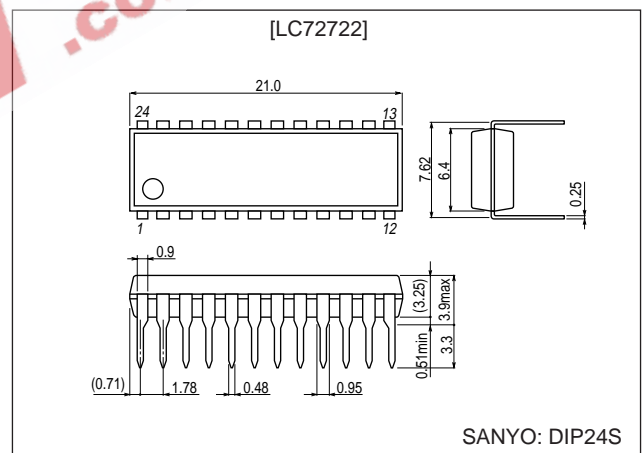

- CCB is a trademark of SANYO ELECTRIC CO., LTD.
- CCB is SANYO's original bus format and all the bus addresses are controlled by SANYO.

■ Any and all SANYO products described or contained herein do not have specifications that can handle applications that require extremely high levels of reliability, such as life-support systems, aircraft's control systems, or other applications whose failure can be reasonably expected to result in serious physical and/or material damage. Consult with your SANYO representative nearest you before using any SANYO products described or contained herein in such applications.

■ SANYO assumes no responsibility for equipment failures that result from using products at values that exceed, even momentarily, rated values (such as maximum ratings, operating condition ranges, or other parameters) listed in products specifications of any and all SANYO products described or contained herein.

SANYO Electric Co.,Ltd. Semiconductor Company

TOKYO OFFICE Tokyo Bldg., 1-10, 1 Chome, Ueno, Taito-ku, TOKYO, 110-8534 JAPAN

LC72722, 72722M, 72722PM

unit: mm

3112A-MFP24S

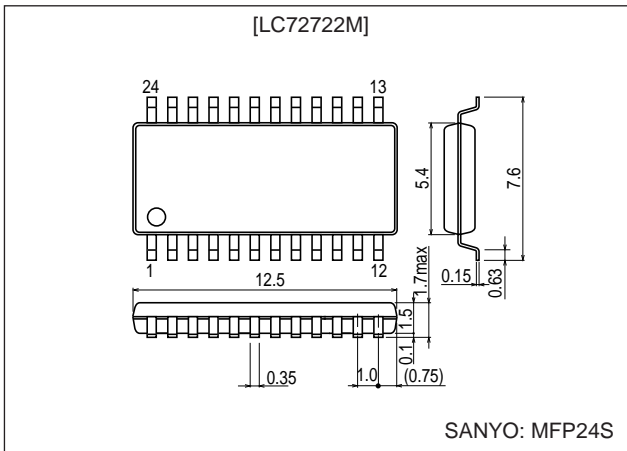

unit: mm

3045C-MFP24

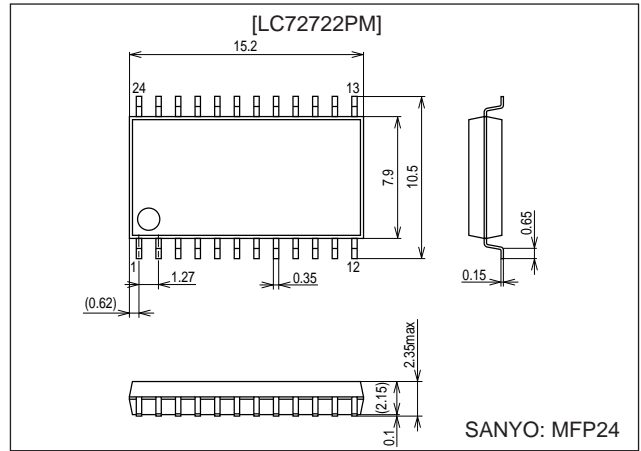

Pin Assignment

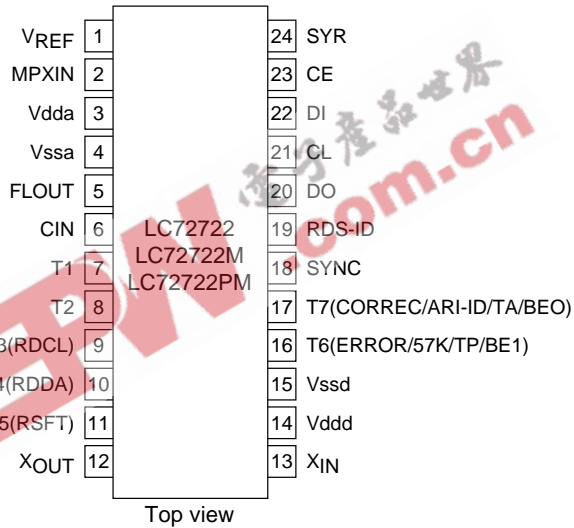

Block Diagram

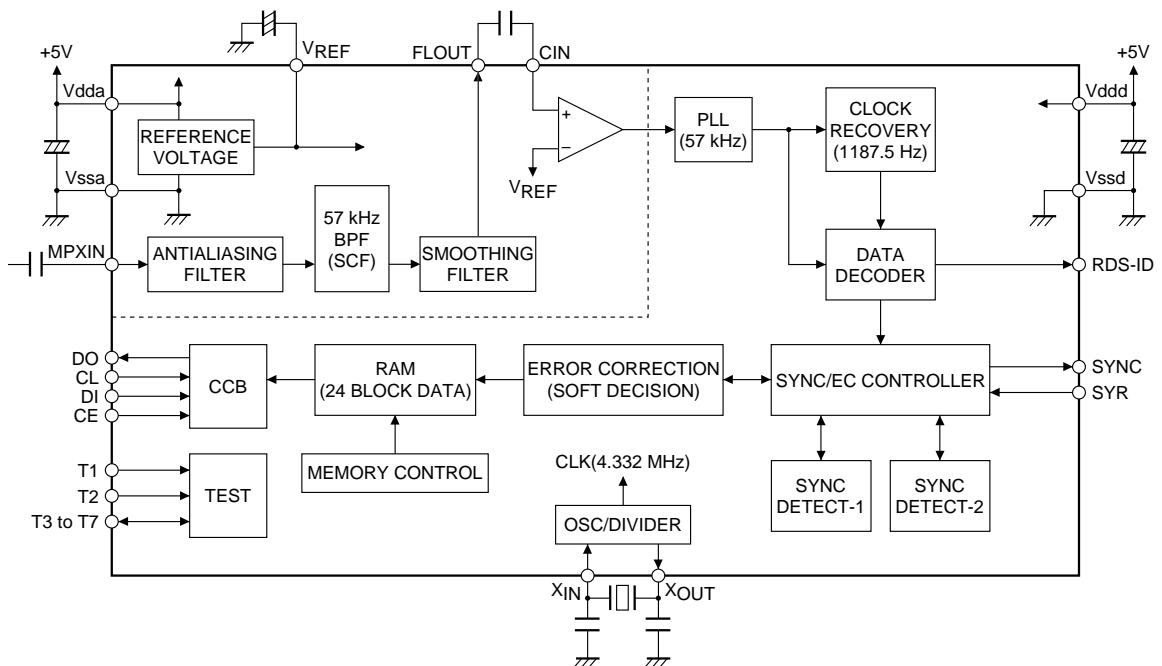

A12364

LC72722, 72722M, 72722PM

Pin Functions

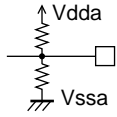
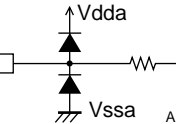
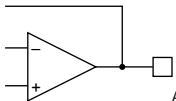
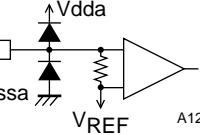
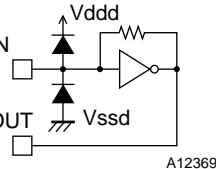
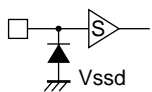
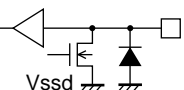
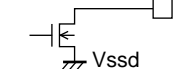
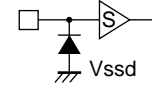
Pin No.	Pin name	Function	I/O	Pin circuit
1	VREF	Reference voltage output ($V_{dda}/2$)	Output	 A12365
2	MPXIN	Baseband (multiplexed) signal input	Input	 A12366
5	FLOUT	Subcarrier output (filter output)	Output	 A12367
6	CIN	Subcarrier input (comparator input)	Input	 A12368
3	Vdda	Analog system power supply (+5 V)	—	—
4	Vssa	Analog system ground	—	—
12	XOUT	Crystal oscillator output (4.332/8.664 MHz)	Output	 A12369
13	XIN	Crystal oscillator input (external reference signal input)	Input	
7	T1	Test input (This pin must always be connected to ground.)	Input	 A12370
8	T2	Test input (standby control) 0: Normal operation, 1: Standby state (crystal oscillator stopped)	Input	
9	T3 (RDCL)	Test I/O (RDS clock output)	I/O*	 A12371
10	T4 (RDDA)	Test I/O (RDS data output)		
11	T5 (RSFT)	Test I/O (soft-decision control data output)		
16	T6 (ERROR/57K/TP/BE1)	Test I/O (error status output, regenerated carrier output, TP output, error block count output)		
17	T7 (CORREC/ARI-ID/TA/BE0)	Test I/O (Error correction status output, SK detection output, TA output, error block count output)	Output	 A12372
18	SYNC	Block synchronization detection output		
19	RDS-ID	RDS detection output	Input	 A12373
20	DO	Data output		
21	CL	Clock input		
22	DI	Data input		
23	CE	Chip enable	—	—
24	SYR	Synchronization and RAM address reset (active high)		
14	Vddd	Digital system power supply (+5 V)	—	—
15	Vssd	Digital system ground	—	—

Note: * Normally function as an output pin. Used as an I/O pin in test mode, which is not available to user applications.

LC72722, 72722M, 72722PM

Specifications

Absolute Maximum Ratings at Ta = 25°C, Vssd = Vssa = 0 V

Parameter	Symbol	Conditions	Ratings	Unit	
Maximum supply voltage	V _{DD} max	V _{ddd} , V _{dda} : V _{dda} ≤ V _{ddd} + 0.3 V	-0.3 to +7.0	V	
Maximum input voltage	V _{IN1} max	CL, DI, CE, SYR, T1, T2, T3, T4, T5, T6, T7, SYNC	-0.3 to +7.0	V	
	V _{IN2} max	XIN	-0.3 to V _{ddd} + 0.3	V	
	V _{IN3} max	MPXIN, CIN	-0.3 to V _{dda} + 0.3	V	
Maximum output voltage	V _{O1} max	DO, SYNC, RDS-ID, T3, T4, T5, T6, T7	-0.3 to +7.0	V	
	V _{O2} max	XOUT	-0.3 to V _{ddd} + 0.3	V	
	V _{O3} max	FLOUT	-0.3 to V _{dda} + 0.3	V	
Maximum output current	I _{O1} max	DO, T3, T4, T5, T6, T7	6.0	mA	
	I _{O2} max	XOUT, FLOUT	3.0	mA	
	I _{O3} max	SYNC, RDS-ID	20.0	mA	
Allowable power dissipation	Pd max	Ta ≤ 85°C	LC72722:DIP24S:	350	mW
			LC72722M:MFP24S:	150	mW
			LC72722PM:MFP24:	175	mW
Operating temperature	Topr		-40 to +85	°C	
Storage temperature	Tstg		-55 to +125	°C	

Allowable Operating Ranges at Ta = -40 to +85°C, Vssd = Vssa = 0 V

Parameter	Symbol	Conditions	Ratings			Unit
			min	typ	max	
Supply voltage	V _{DD1}	V _{ddd} , V _{dda} : V _{ddd} = V _{dda}	4.5	5.0	5.5	V
	V _{DD2}	V _{ddd} : Serial data hold voltage	2.0			V
Input high-level voltage	V _{IH}	CL, DI, CE, SYR, T1, T2	0.7 V _{ddd}		6.5	V
Input low-level voltage	V _{IL}	CL, DI, CE, SYR, T1, T2	0		0.3 V _{ddd}	V
Output voltage	V _O	DO, SYNC, RDS-ID, T3, T4, T5, T6, T7			6.5	V
Input amplitude	V _{IN1}	MPXIN : f = 57 ±2 kHz			50	mVrms
	V _{IN2}	MPXIN : 100% modulation composite	100			mVrms
	V _{XIN}	XIN	400		1500	mVrms
Guaranteed crystal oscillator frequencies	Xtal	XIN, XOUT : Ci ≤ 120 Ω (XS = 0)		4.332		MHz
		XIN, XOUT : Ci ≤ 70 Ω (XS = 1)		8.664		MHz
Crystal oscillator frequency deviation	TXtal	XIN, XOUT : f ₀ = 4.322 MHz, 8.664 MHz			±100	ppm
Data setup time	t _{SU}	DI, CL	0.75			µs
Data hold time	t _{HD}	DI, CL	0.75			µs
Clock low-level time	t _{CL}	CL	0.75			µs
Clock high-level time	t _{CH}	CL	0.75			µs
CE wait time	t _{EL}	CE, CL	0.75			µs
CE setup time	t _{ES}	CE, CL	0.75			µs
CE hold time	t _{EH}	CE, CL	0.75			µs
CE high-level time	t _{CE}	CE			20	ms
Data latch change time	t _{LC}				1.15	µs
Data output time	t _{DC}	DO, CL: Differs depending on the value of the pull-up resistor used.			0.46	µs
	t _{DH}	DO, CE: Differs depending on the value of the			0.46	µs

Electrical Characteristics at Ta = -40 to +85°C, Vssd = Vssa = 0 V

Parameter	Symbol	Conditions	Ratings			Unit
			min	typ	max	
Input resistance	Rmpxin	MPXIN-Vssa : f = 57 kHz		43		kΩ
	Rcin	CIN-Vssa : f = 57 kHz		100		kΩ
Internal feedback resistance	Rf	XIN		1.0		MΩ
Center frequency	fc	FLOUT	56.5	57.0	57.5	kHz
-3 dB bandwidth	BW - 3 dB	FLOUT	2.5	3.0	3.5	kHz
Gain	Gain	MPXIN-FLOUT : f = 57 kHz	28	31	34	dB

Continued on next page.

Continued from preceding page.

Parameter	Symbol	Conditions	Ratings			Unit
			min	typ	max	
Stop band attenuation	Att1	FLOUT : $\Delta f = \pm 7$ kHz	30			dB
	Att2	FLOUT : $f < 45$ kHz, $f > 70$ kHz	40			dB
	Att3	FLOUT : $f < 20$ kHz	50			dB
pull-up resistor used.Reference voltage output	Vref	VREF : Vdda = 5 V		2.5		V
Hysteresis	V _{HIS}	CL, DI, CE, SYR, T1, T2		0.1 V _{ddd}		V
Output low-level voltage	V _{OL1}	DO, T3, T4, T5, T6, T7 : I = 2 mA			0.4	V
	V _{OL2}	SYNC, RDS-ID : I = 8 mA			0.4	V
Input high-level current	I _{H1}	CL, DI, CE, SYR, T1, T2 : V _I = 6.5 V			5.0	μA
	I _{H2}	XIN : V _I = V _{ddd}	2.0		11	μA
Input low-level current	I _{L1}	CL, DI, CE, SYR, T1, T2 : V _I = 0 V			5.0	μA
	I _{L2}	XIN : V _I = 0 V	2.0		11	μA
Output off leakage current	I _{OFF}	DO, SYNC, RDS-ID, T3, T4, T5, T6, T7 : V _O = 6.5 V			5.0	μA
Current drain	I _{dd}	V _{ddd} + V _{dda}		9		mA

CCB Output Data Format

- Each block of output data consists of 32 bits (4 bytes), of which 2 bytes are RDS data and 2 bytes are flag data.
- Any number of 32-bit output data blocks can be output consecutively.
- When there is no data that can be read out in the internal memory, the system outputs blocks of all-zero data consecutively.
- If data readout is interrupted, the next read operation starts with the 32-bit data block whose readout was interrupted. However, if only the last bit remains to be read, it will not be possible to reread that whole block.
- The check bits (10 bits) are not output.
- The data valid/invalid decision is made by referencing the error information flags (E0 to E2) must not be referred to.
- When the first leading bits are not "1010", the read in data is invalid, and the read operation is cancelled.

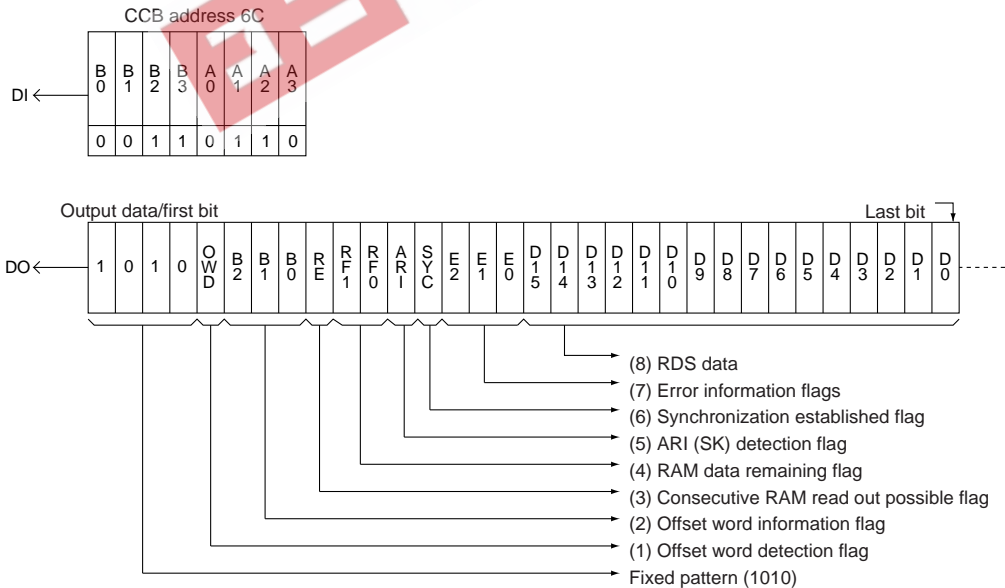

1. Offset word detection flag (1 bit): OWD

OWD	Offset word detection
1	Detected
0	Not detected (protection function operating)

2. Offset word information flag (3 bits): B0 to B2

B2	B1	B0	Offset word
0	0	0	A
0	0	1	B
0	1	0	C
0	1	1	C'
1	0	0	D
1	0	1	E
1	1	0	Unused
1	1	1	Unused

3. Consecutive RAM readout possible flag (1 bit): RE

RE	RAM data information
1	The next data to be read out is in RAM.
0	This data item is the last item in RAM, and the next data is not present.

4. RAM data remaining flag (2 bits): RF0, RF1

RF1	RF0	Remaining data in RAM (number of blocks)
0	0	1 to 7
0	1	8 to 15
1	0	16 to 23
1	1	24

Caution: This value is only meaningful when RE is 1. When RE is 0, there is no data in RAM, even if RF is 00.

If a synchronization reset was applied using SYR, then the backward protection block data that was written to memory is also counted in this value.

5. ARI (SK) detection flag (1 bit): ARI

ARI	SK signal
1	Detected
0	Not detected

6. Synchronization established flag (1 bit): SYC

SYC	Synchronization detection
1	Synchronized
0	Not synchronized

Caution: This flag indicates the synchronization state of the circuit at the point where the data block being output was received.

On the other hand, the SYNC pin (pin 18) output indicates the current synchronization state of the circuit.

7. Error information flags (3 bits): E0 to E2

E2	E1	E0	Number of bits corrected
0	0	0	0 (no errors)
0	0	1	1
0	1	0	2
0	1	1	3
1	0	0	4
1	0	1	5
1	1	0	Correction not possible
1	1	1	Unused

Caution: If the number of errors exceeds the value of the EC0 to EC2 setting (see the section on the CCB input format), the error information flags will be set to the "Correction not possible" value.

When the error flags E0 to E2 are 011 (indicating that correction is not possible) the data must be handled as invalid data.

8. RDS data (16 bits): D0 to D15

This data is output with the MSB first and the LSB last.

Caution: When error correction was not possible, the input data is output without change.

CCB Input Data Format

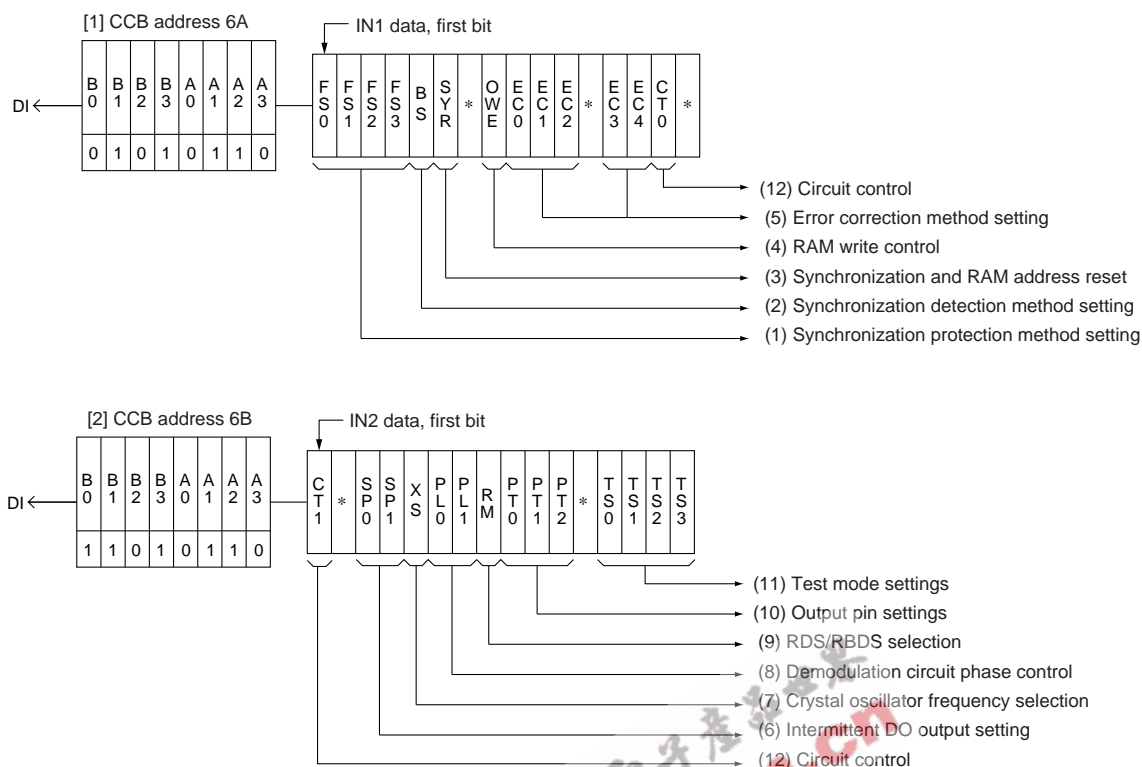

Caution: The bits labeled with an asterisk must be set to 0.

1. Synchronization protection (forward protection) method setting (4 bits): FS0 to FS3

FS3 = 0: If offset words in the correct order could not be detected continuously during the number of blocks specified by FS0 to FS2, take that to be a lost synchronization state.

FS3 = 1: If blocks with uncorrectable errors were received consecutively during the number of blocks specified by FS0 to FS2, take that to be a lost synchronization state.

FS3	FS2	FS1	FS0	Condition for detecting lost synchronization
0	0	0	0	If 3 consecutive blocks matching the FS3 condition are received.
1	0	0	0	If 4 consecutive blocks matching the FS3 condition are received.
0	1	0	0	If 5 consecutive blocks matching the FS3 condition are received.
1	1	0	0	If 6 consecutive blocks matching the FS3 condition are received.
0	0	1	0	If 8 consecutive blocks matching the FS3 condition are received.
1	0	1	0	If 10 consecutive blocks matching the FS3 condition are received.
0	1	1	0	If 12 consecutive blocks matching the FS3 condition are received.
1	1	1	0	If 16 consecutive blocks matching the FS3 condition are received.

Initial value: FS0 = 0, FS1 = 1, FS2 = 0, FS3 = 0

2. Synchronization detection method setting (1 bit): BS

BS	Synchronization detection conditions
0	If, during 3 blocks, 2 blocks of offset words were detected in the correct order.
1	If the offset words were detected in the correct order in 2 consecutive blocks.

Initial value: BS = 0

3. Synchronization and RAM address reset (1 bit): SYR

SYR	Synchronization detection circuit	RAM
0	Normal operation (reset cleared)	Normal write (See the description of the OWE bit.)
1	Forced to the unsynchronized state (synchronization reset)	After the reset is cleared, start writing from the data prior to the establishment of synchronization, i.e. the data in backward protection.

Initial value: SYR = 0

- Caution:
- To apply a synchronization reset, set SYR to 1 temporarily using the CCB, and then set it back to 0 again using the CCB. The circuit will start synchronization capture operation at the point SYR is set to 0.
 - The SYR pin (pin 24) also provides an identical reset control operation. Applications can use either method. However, the control method that is not used must be set to 0 at all times. Any pulse with a width of over 250 ns will suffice.
 - A reset must be applied immediately after the reception channel is changed. If a reset is not applied, reception data from the previous channel may remain in memory.
 - Data read out after a synchronization reset is read out starting with the backward protection block data preceding the establishment of synchronization.

4. RAM write control (1 bit): OWE

OWE	RAM write conditions
0	Only data for which synchronization had been established is written.
1	Data for which synchronization not has been established (unsynchronized data) is also written. (However, this applies when SYR = 0.)

Initial value: OWE = 0

5. Error correction method setting (5 bits): EC0 to EC4

E C 0	E C 1	E C 2	Number of bits corrected	E C 3	E C 4	Soft-decision setting
0	0	0	0 (error detection only)	0	0	Mode 0: Hard decision
1	0	0	1 or fewer bits	1	0	Mode 1: Soft decision A
0	1	0	2 or fewer bits	0	1	Mode 2: Soft decision B
1	1	0	3 or fewer bits	1	1	Illegal value
0	0	1	4 or fewer bits			
1	0	1	5 or fewer bits			
0	1	1	Illegal value			
1	1	1	Illegal value			

Initial values: EC0 = 0, EC1 = 1, EC2 = 0, EC3 = 0, EC4 = 1

- Caution:
- If soft-decision A or soft-decision B is specified, soft-decision control will be performed even if the number of bits corrected is set to 0 (error detection only). With these settings, data will be output for blocks with no errors.
 - As opposed to soft-decision B, the soft-decision A setting suppresses soft decision error correction.

6. Intermittent DO output setting

SP0	SP1	DO output state
0	0	DO goes low when one or more blocks of data are written to memory.
1	0	DO goes low when 4 or more blocks of data are written to memory.
0	1	DO goes low when 8 or more blocks of data are written to memory.
1	1	DO goes low when 12 or more blocks of data are written to memory.

Initial values: SP0 = 0, SP1 = 0

7. Crystal oscillator frequency selection (1 bit): XS

XS = 0: 4.332 MHz

XS = 1: 8.664 MHz

Initial value: XS = 0

8. Demodulation circuit phase control (2 bits): PL0, PL1

PL0	PL1	Demodulation circuit phase control
0	0/1	<Normal operation> when ARI presence or absence is unclear.
1	0	If the circuit determines that the ARI signal is absent: 90° phase
	1	If the circuit determines that the ARI signal is present: 0° phase

Initial values: PL0 = 0, PL1 = 1

Caution: 1. When PL0 is 0 (normal operation), the IC detects the presence or absence of the ARI signal and reproduces the RDS data by automatically controlling the demodulation phase with respect to the reproduced carrier. However, the initial phase following a synchronization reset is set by PL1.

2. If PL0 is set to 1, the demodulation circuit phase is locked according to the PL1 setting at either 90° (PL1 = 0) or 0° (PL1 = 1), allowing RDS data to be reproduced. When ARI is not present, PL1 should be set to 0, since the RDS data is reproduced by detecting at a phase of 90° with respect to the reproduced carrier. When ARI is present, PL1 should be set to 1, since detection is at 0°. In cases where the ARI presence is known in advance, more stable reproduction can be achieved by fixing the demodulation phase in this manner.

9. RDS/RBDS (MMBS) selection (1 bit): RM

RM	RBDS support	Decoding method
0	None	Only RDS data is decoded correctly (Offset word E is not detected.)
1	Provided	RDS and MMBS data is decoded correctly (Offset word E is also detected.)

Initial value: RM = 0

10. Output pin settings (3 bits): PT0 to PT2

These bits control the T3, T4, T5, T6, T7, SYNC, and RDS-ID pins.

Mode	P	P	P	T3	T4	T5	T6				T7				
	T	T	T				RDCL	RDDA	RSFT	ERROR	57K	TP	BE1	CORREC	ARI-ID
0	0	0	0	—	—	—	—	—	—	—	—	—	—	—	—
1	1	0	0	—	—	—	—	—	○	—	—	—	—	○	—
2	0	1	0	○	○	○	—	○	—	—	—	○	—	—	—
3	1	1	0	○	○	○	○	—	—	—	○	—	—	—	—
4	0	0	1	—	—	—	—	—	—	○	—	—	—	—	○
5	1	0	1	—	—	—	—	—	●	—	—	—	—	●	—
6	0	1	1	○	○	○	—	●	—	—	—	—	●	—	—
7	1	1	1	○	○	○	●	—	—	—	—	●	—	—	—

—: Open, ○, ●: Output enabled (● = reverse polarity)

Initial values: PT0 = 1, PT1 = 1, PT2 = 0 (mode 3)

Caution: 1. When PT2 is set to 1, T6 (ERROR/57K/TP), T7 (CORREC/ARI-ID/TA) SYNC, and RDS-ID pins change to active high.

2. The output pins (T3 to T7, SYNC, and RDS-ID) are all open-drain pins, and require external pull-up resistors to output data.

Mode 1 (PT2 = 0)	Pin T6 (TP)
TP = 0 detected	High (1)
TP = 1 detected	Low (0)

TP = Traffic program code

Mode 1 (PT2 = 0)	Pin T7 (TA)
TA = 0 detected	High (1)
TA = 1 detected	Low (0)

TA = Traffic announcement code

Mode 2 (PT2 = 0)	Pin T7 (ARI-ID)
No SK	High (1)
SK present	Low (0)

Mode 3 (PT2 = 0)	Pin T6 (ERROR)	Pin T7 (CORREC)
Correction not possible	Low (0)	Low (0)
Errors corrected	High (1)	Low (0)
No errors	High (1)	High (1)

Mode 4	Pin T6 (BE1)	Pin T7 (BE0)
Number of error blocks (B)		
B = 0	Low (0)	Low (0)
$1 \leq B \leq 20$	Low (0)	High (1)
$20 < B \leq 40$	High (1)	Low (0)
$40 < B \leq 48$	High (1)	High (1)

These pins indicate the number of blocks in a set of 48 blocks that had errors before correction. The output polarity of these pins is fixed at the values listed in the table.

Mode (PT2 = 0)	The SYNC pin
0 to 2	When synchronized: Low (0). When unsynchronized: High (1)
3	When synchronized: Goes high for a fixed period (421 μ s) at the start of a block and then goes low. When unsynchronized: High (1)

Caution: The output indicates the synchronization state for the previous block.

When PT2 = 0	The RDS-ID pin
No RDS	High (1)
RDS present	Low (0)

11. Test mode settings (4 bits): TS0 to TS3

Initial values: TS0 = 0, TS1 = 0, TS2 = 0, TS3 = 0

(Applications must set these bits to the above values.)

Notes: The T1 and T2 pins (pins 7 and 8) are related to test mode as follows:

Pin T1	Pin T2	LSI operation	Notes
0	0	Normal operating mode	These states are user settable
0	1	Standby mode (crystal oscillator stopped)	
1	0/1	LSI test mode	Users cannot use this state

The T1 pin must be tied to V_{SS} (0 V).

12. Circuit control (2 bits): CT0 and CT1

Item	Control
CT0 RSFT control	When set to 1, soft-decision control data (RSFT) is more difficult to generate.
CT1 RDS-ID detection condition	When set to 1, the RDS-ID detection conditions are made more restrictive.

Initial values: CT0 = 0, CT1 = 0

RDCL/RDDA/RSFT and ERROR/CORREC/SYNC Output Timing

Timing 1

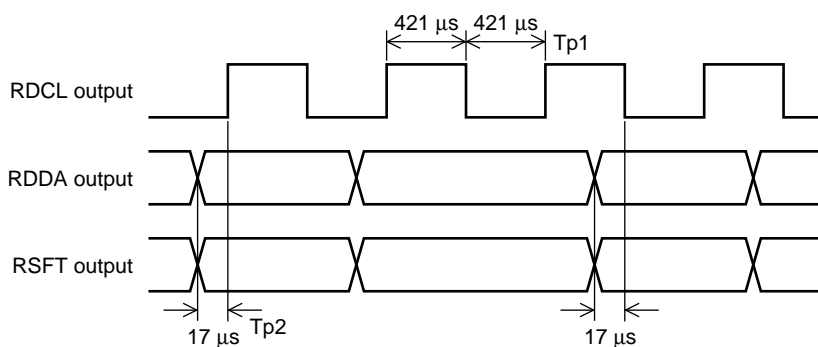

A12377

Timing 2 (mode 3, PT2 = 0)

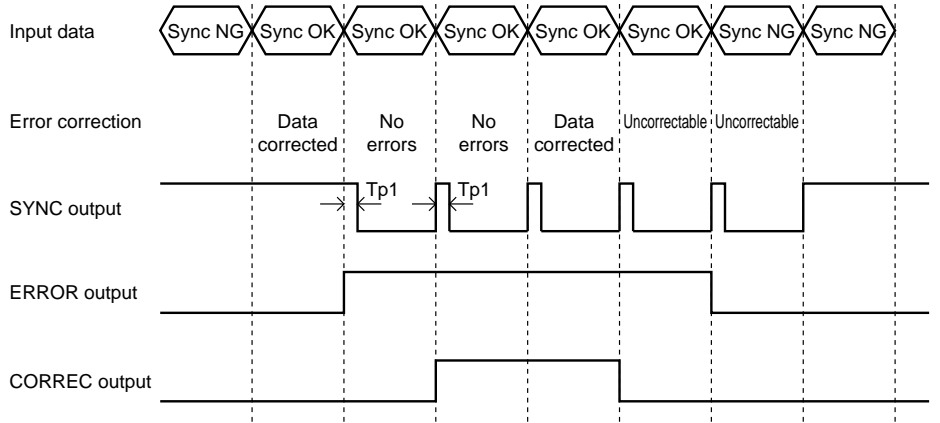

A12378

Serial Data Input and Output Methods

Data is input and output using the CCB (computer control bus), which is the Sanyo audio IC serial bus format. This IC adopts an 8-bit address CCB format.

	I/O mode	(LSB)				Address				(MSB)	Comment
		B0	B1	B2	B3	A0	A1	A2	A3		
1	IN1 (6A)	0	1	0	1	0	1	1	0	<ul style="list-style-type: none"> Control data input mode, also referred to as "serial data input" mode. This is a 16-bit data input mode. 	
2	IN2 (6B)	1	1	0	1	0	1	1	0	<ul style="list-style-type: none"> Control data input mode, also referred to as "serial data input" mode. This is a 16-bit data input mode. 	
3	OUT (6C)	0	0	1	1	0	1	1	0	<ul style="list-style-type: none"> Data output mode, also referred to as "serial data output" mode. The data for multiple blocks can be output sequentially in this mode. 	

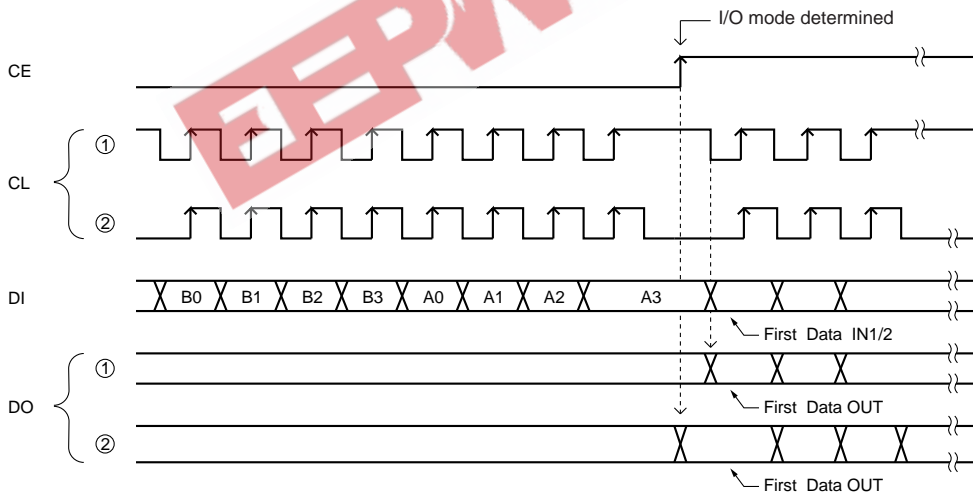

① For the CL normal high state

② For the CL normal low state

A12379

Serial data input (IN1, IN2) $t_{SU}, t_{HD}, t_{EL}, t_{ES}, t_{EH} \geq 0.75 \mu s$ $t_{LC} < 1.15 \mu s$ $t_{CE} < 20 ms$

CL: Normal high

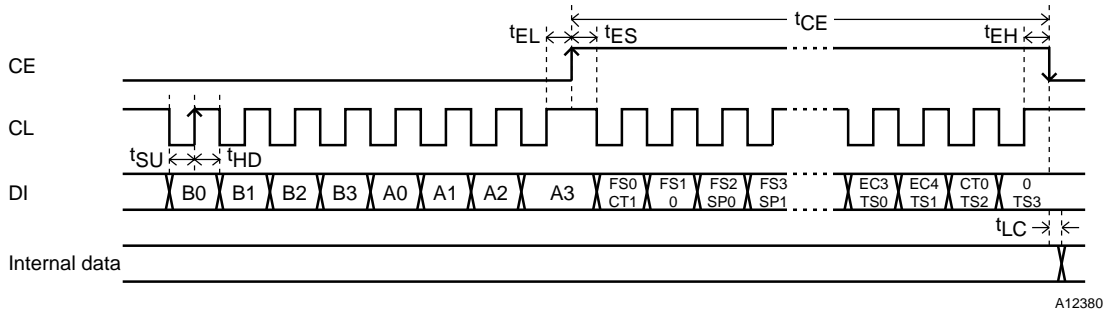

CL: Normal low

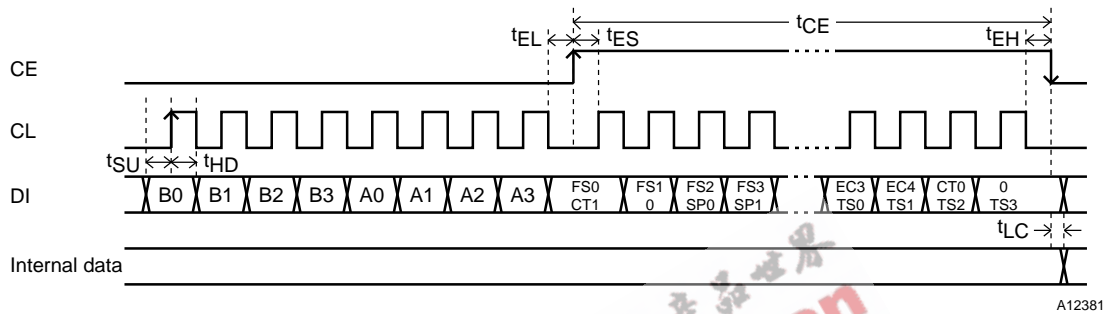

Serial data output (OUT) $t_{SU}, t_{HD}, t_{EL}, t_{ES}, t_{EH} \geq 0.75 \mu s$ $t_{DC}, t_{DH} < 0.46 \mu s$ $t_{CE} < 20 ms$

CL: Normal high

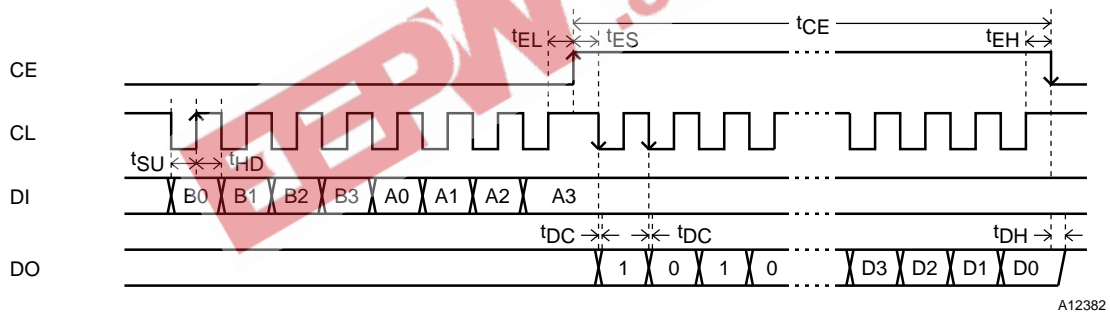

CL: Normal low

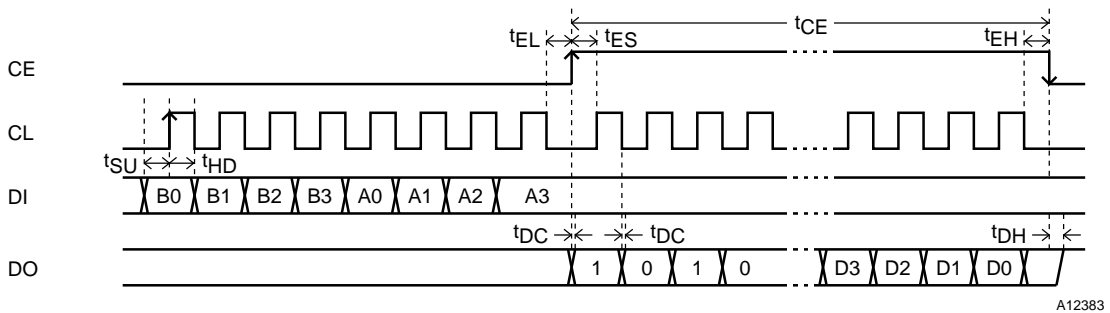

- Notes:
1. Since the DO pin is an n-channel open-drain output, the transition times (t_{DC}, t_{DH}) will differ with the value of the pull-up resistor used.
 2. The CE, CL, DI, and DO pins can be connected to the corresponding pins on other ICs that use the CCB interface. (However, we recommend connecting the DO and CE pins separately if the number of available microcontroller ports allows it.)
 3. Serial data I/O becomes possible after the crystal oscillator starts oscillation.

Serial data timing

CL: Normal high

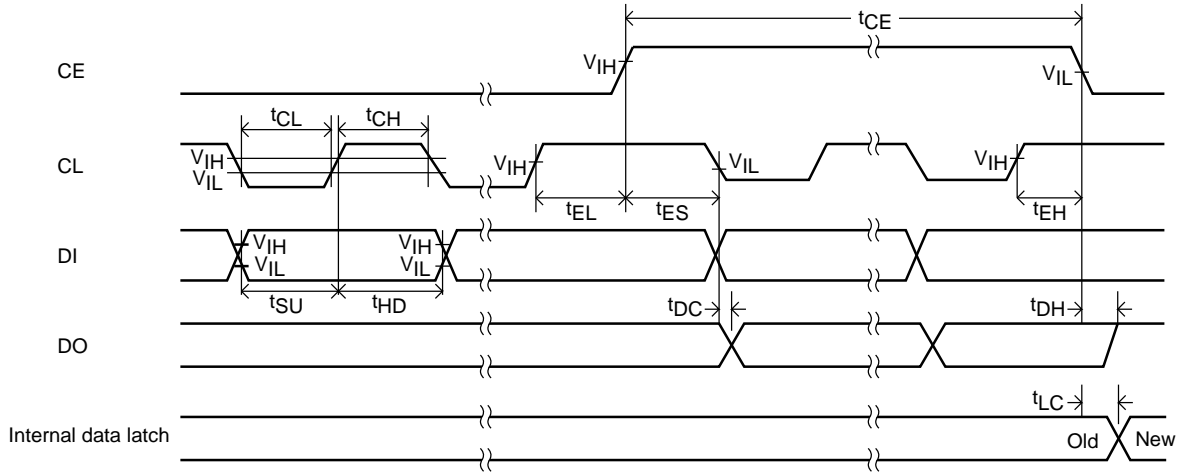

A12384

CL: Normal low

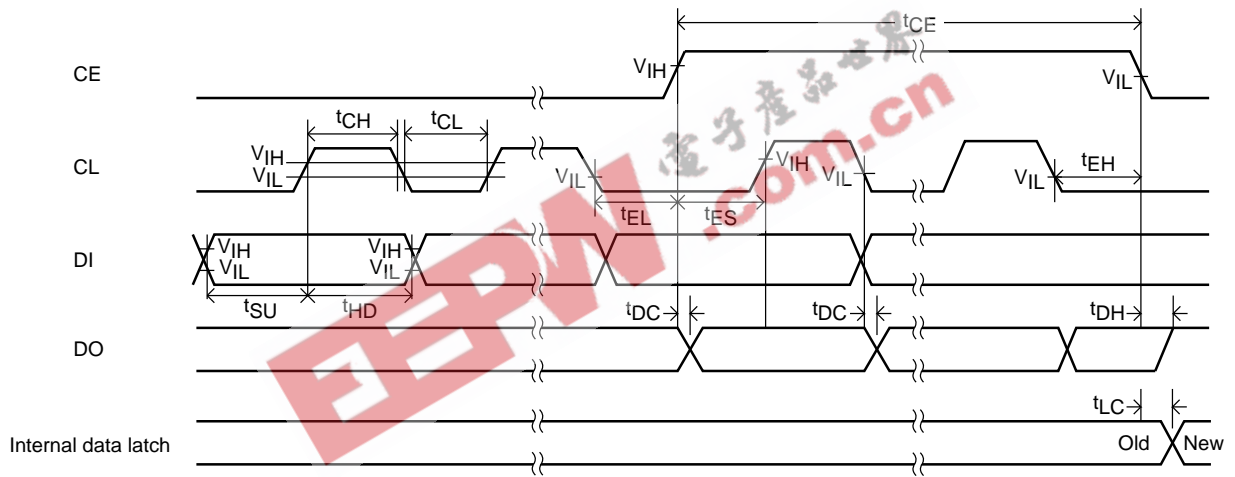

A12385

Parameter	Symbol	Conditions	Ratings			Unit
			min	typ	max	
Data setup time	t_{SU}	DI, CL	0.75			μs
Data hold time	t_{HD}	DI, CL	0.75			μs
Clock low-level time	t_{CL}	CL	0.75			μs
Clock high-level time	t_{CH}	CL	0.75			μs
CE wait time	t_{EL}	CE, CL	0.75			μs
CE setup time	t_{ES}	CE, CL	0.75			μs
CE hold time	t_{EH}	CE, CL	0.75			μs
CE high-level time	t_{CE}	CE			20	ms
Data latch transition time	t_{LC}				1.15	μs
Data output time	t_{DC}	DO, CL			0.46	μs
	t_{DH}	DO, CE	Differs with the value of the pull-up resistor used.		0.46	μs

DO pin operation

This IC incorporates a RAM data buffer that can hold up to 24 blocks of data. At the point where one block of data is written to this RAM, the IC issues a read request by switching the DO pin from high to low when $SP = 00$. (See the CCB input data format.)

The DO pin always goes high for a fixed period ($T_{do} = 265 \mu s$) after a readout and CE goes low. When all the data in the data buffer has been read out, the DO pin is held in the high state until a new block of data has been written to the RAM. (When $SP = 00$) If there is data that has not yet been read remaining in the data buffer, the DO pin goes low after the T_{do} time has elapsed.

After a synchronization reset, the DO pin is held high until synchronization is established. It goes low at the point where the IC synchronizes (When $SP = 00$).

1. When the DO pin is high following the $265 \mu s$ period (T_{do}) after data is read out

Here, the buffer is in the empty state, i.e. the state where new data has not been written. After this, when the DO pin goes low, applications are guaranteed to be able to read out that data without it being overwritten by new data if they start a readout operation within 480 ms of DO going low.

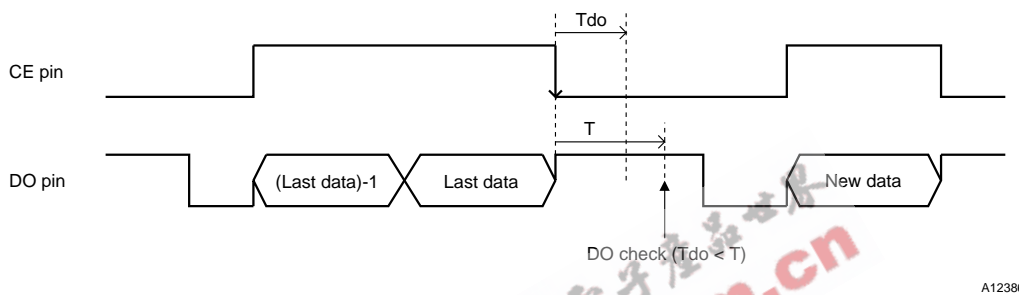

2. When DO goes low $265 \mu s$ after data is read out

Here, there is data that has not been read out remaining in the data buffer. In this case, applications are guaranteed to be able to read out that data without it being overwritten by new data if they start a readout operation within 20 ms of DO going low. (Note that this is the worst case condition.)

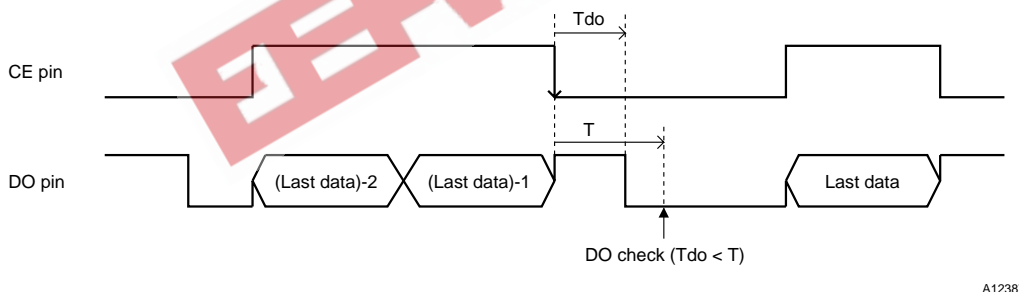

- Notes:
1. Although an application can determine whether or not there is data remaining in the buffer by checking the DO level with the above timing, checking the RE and RF flags in the serial data is a preferable method.
 2. Applications are not limited to reading out one block of data at a time, but rather can read out multiple blocks of data continuously as described above. When using this method, if an application references the RE and RF flags in the data while reading out data, it can determine the amount of data remaining. However, the length of the period for data readout (the period the CE pin remains high) must be kept under 20 ms.
 3. If the DO pin is shared with other ICs that use the CCB interface, the application must identify which IC issued the readout request. One method is to read out data from the LC72722 and either check whether meaningful data has been read (if the LC72722 is not requesting a read, data consisting of all zeros will be read out) or check whether the DO level goes low within the $256 \mu s$ following the completion of the read (if the DO pin goes low, then the request was from another IC).

Sample Application Circuit

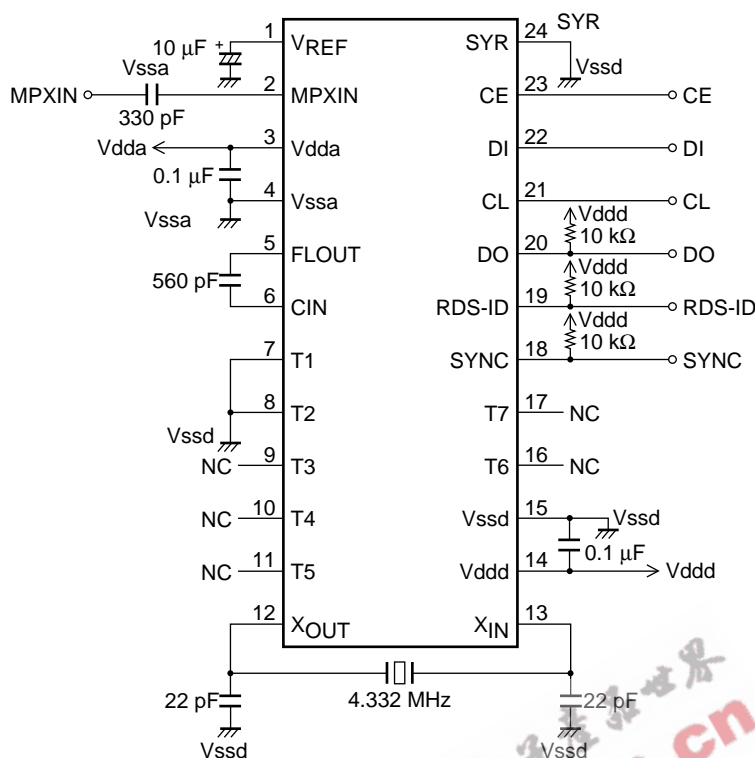

A12388

- Notes: 1. Determine the value of the DO pin pull-up resistor based on the required serial data transfer speed.
 2. If the SYR pin is unused, it must be connected to ground.

- Specifications of any and all SANYO products described or contained herein stipulate the performance, characteristics, and functions of the described products in the independent state, and are not guarantees of the performance, characteristics, and functions of the described products as mounted in the customer's products or equipment. To verify symptoms and states that cannot be evaluated in an independent device, the customer should always evaluate and test devices mounted in the customer's products or equipment.
- SANYO Electric Co., Ltd. strives to supply high-quality high-reliability products. However, any and all semiconductor products fail with some probability. It is possible that these probabilistic failures could give rise to accidents or events that could endanger human lives, that could give rise to smoke or fire, or that could cause damage to other property. When designing equipment, adopt safety measures so that these kinds of accidents or events cannot occur. Such measures include but are not limited to protective circuits and error prevention circuits for safe design, redundant design, and structural design.
- In the event that any or all SANYO products (including technical data, services) described or contained herein are controlled under any of applicable local export control laws and regulations, such products must not be exported without obtaining the export license from the authorities concerned in accordance with the above law.
- No part of this publication may be reproduced or transmitted in any form or by any means, electronic or mechanical, including photocopying and recording, or any information storage or retrieval system, or otherwise, without the prior written permission of SANYO Electric Co., Ltd.
- Any and all information described or contained herein are subject to change without notice due to product/technology improvement, etc. When designing equipment, refer to the "Delivery Specification" for the SANYO product that you intend to use.
- Information (including circuit diagrams and circuit parameters) herein is for example only; it is not guaranteed for volume production. SANYO believes information herein is accurate and reliable, but no guarantees are made or implied regarding its use or any infringements of intellectual property rights or other rights of third parties.

This catalog provides information as of May, 2002. Specifications and information herein are subject to change without notice.