

LM321

Low Power Single Op Amp

General Description

The LM321 brings performance and economy to low power systems. With a high unity gain frequency and a guaranteed $0.4V/\mu s$ slew rate, the quiescent current is only $430\mu A$ /amplifier (5V). The input common mode range includes ground and therefore the device is able to operate in single supply applications as well as in dual supply applications. It is also capable of comfortably driving large capacitive loads.

The LM321 is available in the SOT23-5 package. Overall the LM321 is a low power, wide supply range performance op amp that can be designed into a wide range of applications at an economical price without sacrificing valuable board space.

Features

($V_{CC} = 5V$, $T_A = 25^\circ C$. Typical values unless specified).

- Gain-Bandwidth product 1MHz
- Low supply current 430 μ A
- Low input bias current 45nA
- Wide supply voltage range +3V to +32V
- Stable with high capacitive loads
- Single version of LM324

Applications

- Chargers
- Power supplies
- Industrial: controls, instruments
- Desktops
- Communications infrastructure

Connection Diagram

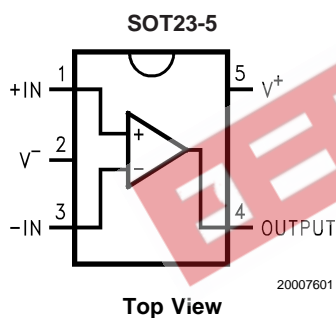

Application Circuit

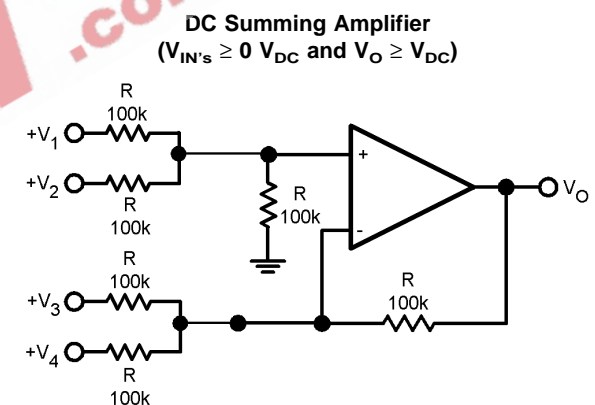

Where: $V_O = V_1 + V_2 - V_3 - V_4$, $(V_1 + V_2) \geq (V_3 + V_4)$ to keep $V_O > 0$ V_{DC}

Ordering Information

Package	Part Number	Package Marking	Transport Media	NSC Drawing
5-Pin SOT-23	LM321MF	A63A	1k Units Tape and Reel	MF05A
	LM321MFX		3k Units Tape and Reel	

Absolute Maximum Ratings (Note 1)

If Military/Aerospace specified devices are required, please contact the National Semiconductor Sales Office/Distributors for availability and specifications.

Differential Input Voltage	±Supply Voltage
Input Current ($V_{IN} < -0.3V$) (Note 6)	50mA
Supply Voltage ($V^+ - V^-$)	32V
Input Voltage	-0.3V to +32V
Output Short Circuit to GND, $V^+ \leq 15V$ and $T_A = 25^\circ C$ (Note 2)	Continuous
Storage Temperature Range	-65°C to 150°C

Junction Temperature (Note 3)	150°C
Mounting Temperature	
Lead Temp (Soldering, 10 sec)	260°C
Infrared (10 sec)	215°C
Thermal Resistance to Ambient (θ_{JA})	265°C/W
ESD Tolerance (Note 10)	300V

Operating Ratings (Note 1)

Temperature Range	-40°C to 85°C
Supply Voltage	3V to 30V

Electrical Characteristics Unless otherwise specified, all limits guaranteed for at $T_A = 25^\circ C$; $V^+ = 5V$, $V^- = 0V$, $V_O = 1.4V$. **Boldface** limits apply at temperature extremes.

Symbol	Parameter	Conditions	Min (Note 5)	Typ (Note 4)	Max (Note 5)	Units
V_{OS}	Input Offset Voltage	(Note 7)		2	7 9	mV
I_{OS}	Input Offset Current			5	50 150	nA
I_B	Input Bias Current (Note 8)			45	250 500	nA
V_{CM}	Input Common-Mode Voltage Range	$V^+ = 30V$ (Note 9) For CMRR $> = 50dB$	0		$V^+ - 1.5$ $V^+ - 2$	V
A_V	Large Signal Voltage Gain	$(V^+ = 15V, R_L = 2k\Omega$ $V_O = 1.4V$ to 11.4V)	25 15	100		V/mV
PSRR	Power Supply Rejection Ratio	$R_S \leq 10k\Omega$, $V^+ \leq 5V$ to 30V	65	100		dB
CMRR	Common Mode Rejection Ratio	$R_S \leq 10k\Omega$	65	85		dB
V_O	Output Swing	V_{OH}	$V^+ = 30V, R_L = 2k\Omega$	26		V
			$V^+ = 30V, R_L = 10k\Omega$	27	28	
		V_{OL}	$V^+ = 5V, R_L = 10k\Omega$		5	20
I_S	Supply Current, No Load	$V^+ = 5V$		0.430 0.7	1.15 1.2	mA
		$V^+ = 30V$		0.660 1.5	2.85 3	
I_{SOURCE}	Output Current Sourcing	$V_{ID} = +1V, V^+ = 15V$, $V_O = 2V$	20 10	40 20		mA
I_{SINK}	Output Current Sinking	$V_{ID} = -1V$ $V^+ = 15V, V_O = 2V$	10 5	20 8		mA
		$V_{ID} = -1V$ $V^+ = 15V, V_O = 0.2V$	12	100		μA
I_O	Output Short Circuit to Ground (Note 2)	$V^+ = 15V$		40	85	mA
SR	Slew Rate	$V^+ = 15V, R_L = 2k\Omega$, $V_{IN} = 0.5$ to 3V $C_L = 100pF$, Unity Gain		0.4		V/ μs
GBW	Gain Bandwidth Product	$V^+ = 30V, f = 100kHz$, $V_{IN} = 10mV, R_L = 2k\Omega$, $C_L = 100pF$		1		MHz
ϕ_m	Phase Margin			60		deg

Electrical Characteristics Unless otherwise specified, all limits guaranteed for at $T_A = 25^\circ\text{C}$; $V^+ = 5\text{V}$, $V^- = 0\text{V}$, $V_O = 1.4\text{V}$. **Boldface** limits apply at temperature extremes. (Continued)

Symbol	Parameter	Conditions	Min (Note 5)	Typ (Note 4)	Max (Note 5)	Units
THD	Total Harmonic Distortion	$f = 1\text{kHz}$, $A_V = 20\text{dB}$ $R_L = 2\text{k}\Omega$, $V_O = 2V_{PP}$, $C_L = 100\text{pF}$, $V^+ = 30\text{V}$		0.015		%
e_n	Equivalent Input Noise Voltage	$f = 1\text{kHz}$, $R_S = 100\Omega$ $V^+ = 30\text{V}$		40		$\text{nV}/\sqrt{\text{Hz}}$

Note 1: Absolute Maximum Ratings indicate limits beyond which damage to the device may occur. Operating Ratings indicate conditions for which the device is intended to be functional, but specific performance is not guaranteed. For guaranteed specifications and the test conditions, see the Electrical Characteristics.

Note 2: Short circuits from the output V^+ can cause excessive heating and eventual destruction. When considering short circuits to ground the maximum output current is approximately 40mA independent of the magnitude of V^+ . At values of supply voltage in excess of +15V, continuous short circuits can exceed the power dissipation ratings and cause eventual destruction.

Note 3: The maximum power dissipation is a function of $T_{J(\text{MAX})}$, θ_{JA} , and T_A . The maximum allowable power dissipation at any ambient temperature is $P_D = (T_{J(\text{MAX})} - T_A) / \theta_{JA}$. All numbers apply for packages soldered directly onto a PC board.

Note 4: Typical values represent the most likely parametric norm.

Note 5: All limits are guaranteed by testing or statistical analysis.

Note 6: This input current will only exist when the voltage at any of the input leads is driven negative. It is due to the collector base junction of the input PNP transistors becoming forward biased and thereby acting as input diode clamps. In addition to this diode action, there is also lateral NPN parasitic transistor action on the IC chip. This transistor action can cause the output voltages of the op amps to go to the V^+ voltage level (or to ground for a large overdrive) for the time duration that an input is driven negative. This is not destructive and normal output states will re-establish when the input voltage, which was negative, again returns to a value greater than -0.36V (at 25°C).

Note 7: $V_O \cong 1.4\text{V}$, $R_S = 0\Omega$ with V^+ from 5V to 30V; and over the full input common-mode range (0V to $V^+ - 1.5\text{V}$) at 25°C .

Note 8: The direction of the input current is out of the IC due to the PNP input stage. This current is essentially constant, independent of the state of the output so no loading change exists on the input lines.

Note 9: The input common-mode voltage of either input signal voltage should not be allowed to go negative by more than 0.3V (at 25°C). The upper end of the common-mode voltage range is $V^+ - 1.5\text{V}$ at 25°C , but either or both inputs can go to +32V without damage, independent of the magnitude of V^+ .

Note 10: Human Body Model, 1.5k Ω in series with 100pF.

Simplified Schematic

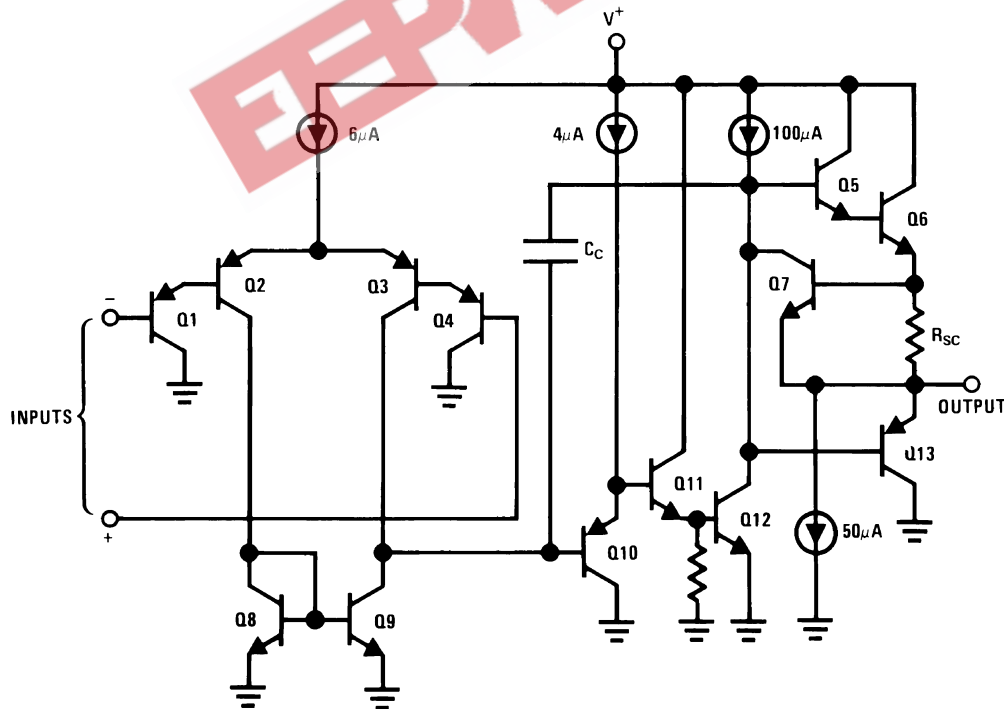

20007603

Typical Performance Characteristics Unless otherwise specified, $V_S = +5V$, single supply, $T_A = 25^\circ C$.

Small Signal Pulse Response

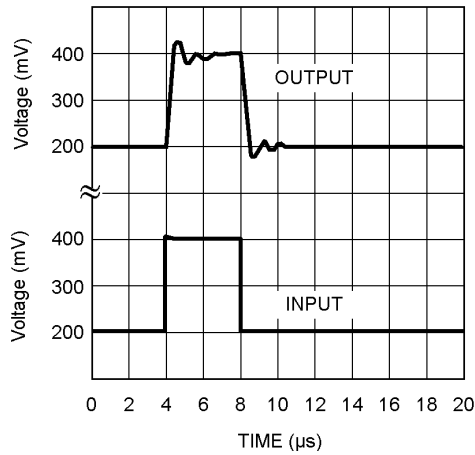

20007604

Large Signal Pulse Response

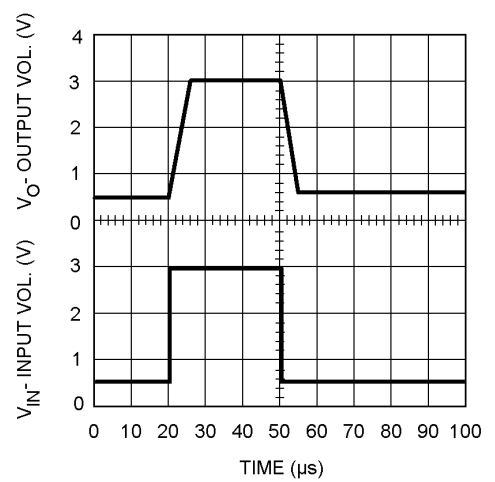

20007605

Supply Current vs. Supply Voltage

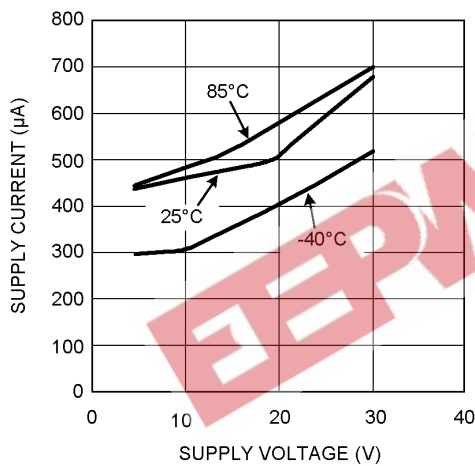

20007612

Sinking Current vs. Output Voltage

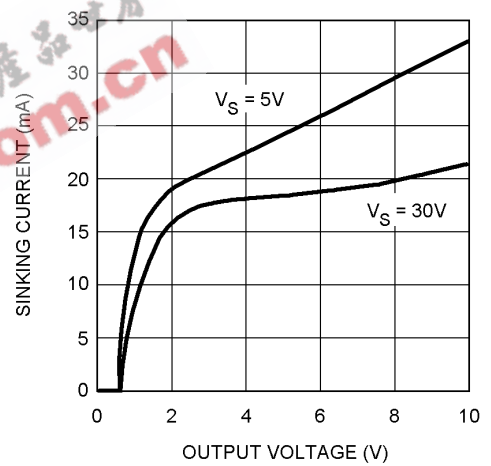

20007613

Source Current vs. Output Voltage

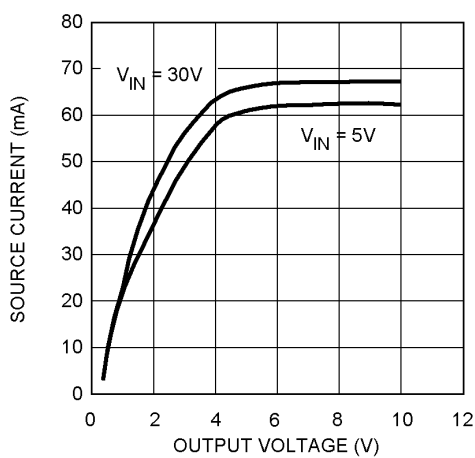

20007617

Open Loop Frequency Response

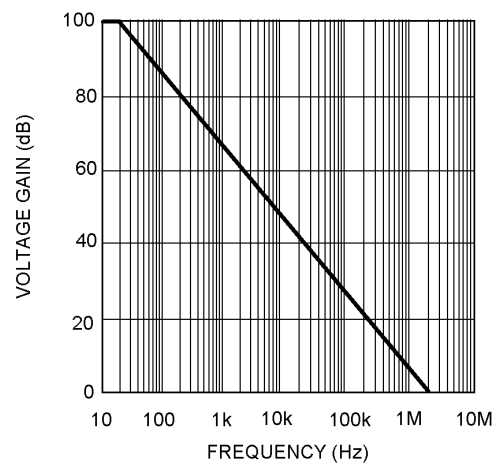

20007614

Application Hints

The LM321 op amp can operate with a single or dual power supply voltage, has true-differential inputs, and remain in the linear mode with an input common-mode voltage of $0 V_{DC}$. This amplifier operates over a wide range of power supply voltages, with little change in performance characteristics. At 25°C amplifier operation is possible down to a minimum supply voltage of 3V .

Large differential input voltages can be easily accommodated and, as input differential voltage protection diodes are not needed, no large input currents result from large differential input voltages. The differential input voltage may be larger than V^+ without damaging the device. Protection should be provided to prevent the input voltages from going negative more than $-0.3 V_{DC}$ (at 25°C). An input clamp diode with a resistor to the IC input terminal can be used.

To reduce the power supply drain, the amplifier has a class A output stage for small signal levels which converts to class B in a large signal mode. This allows the amplifiers to both source and sink large output currents. Therefore both NPN and PNP external current boost transistors can be used to extend the power capability of the basic amplifiers. The output voltage needs to raise approximately 1 diode drop above ground to bias the on-chip vertical PNP transistor for output current sinking applications.

For AC applications, where the load is capacitively coupled to the output of the amplifier, a resistor should be used, from the output of the amplifier to ground to increase the class A bias current and to reduce distortion.

Capacitive loads which are applied directly to the output of the amplifier reduce the loop stability margin. Values of 50pF

can be accommodated using the worst-case non-inverting unity gain connection. Large closed loop gains or resistive isolation should be used if large load capacitance must be driven by the amplifier.

The bias network of the LM321 establishes a supply current which is independent of the magnitude of the power supply voltage over the range of from $3 V_{DC}$ to $30 V_{DC}$.

Output short circuits either to ground or to the positive power supply should be of short time duration. Units can be destroyed, not as a result of the short circuit current causing metal fusing, but rather due to the large increase in IC chip dissipation which will cause eventual failure due to excessive junction temperatures. The larger value of output source current which is available at 25°C provides a larger output current capability at elevated temperatures than a standard IC op amp.

The circuits presented in the section on typical applications emphasize operation on only a single power supply voltage. If complementary power supplies are available, all of the standard op amp circuits can be used. In general, introducing a pseudo-ground (a bias voltage reference of $V^+/2$) will allow operation above and below this value in single power supply systems. Many application circuits are shown which take advantage of the wide input common-mode voltage range which includes ground. In most cases, input biasing is not required and input voltages which range to ground can easily be accommodated.

Typical Applications

Non-Inverting DC Gain (0V Input = 0V Output)

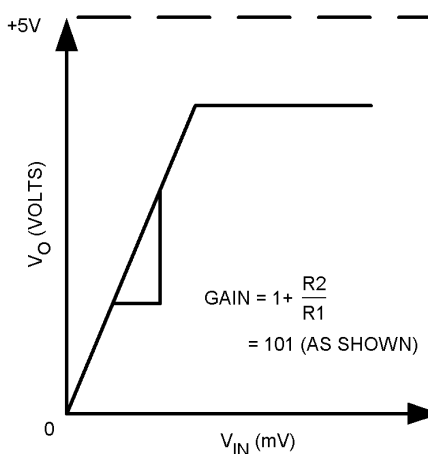
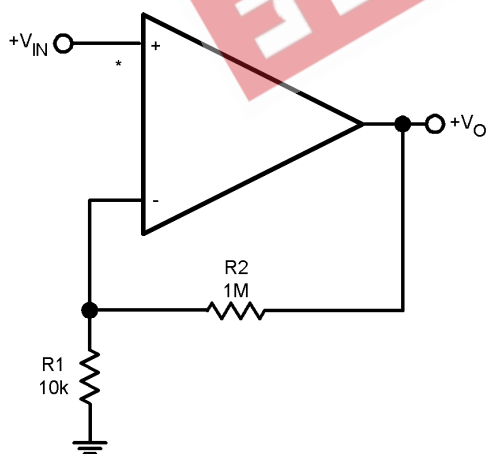

* R NOT NEEDED DUE TO TEMPERATURE INDEPENDENT I_{IN}

20007606

Typical Applications (Continued)

Amplitude Modulator Circuit

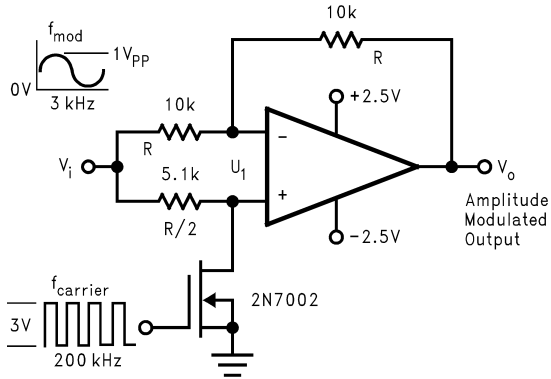

20007602

DC Summing Amplifier ($V_{IN's} \geq 0 V_{DC}$ and $V_O \geq V_{DC}$)

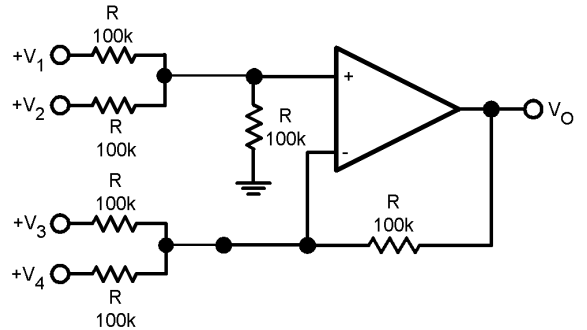

20007607

Where: $V_O = V_1 + V_2 - V_3 - V_4$, $(V_1 + V_2) \geq (V_3 + V_4)$ to keep $V_O > 0 V_{DC}$

Power Amplifier

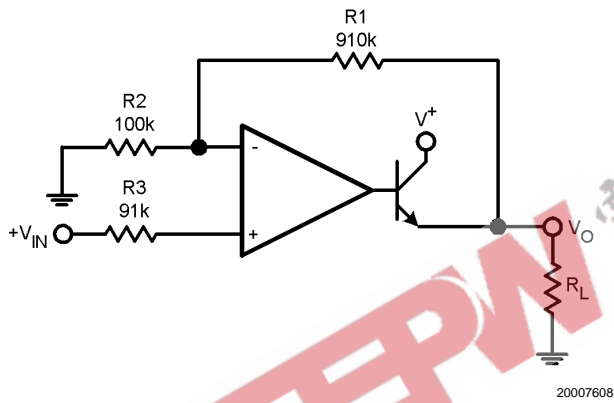

20007608

$V_O = 0 V_{DC}$ for $V_{IN} = 0 V_{DC}$, $A_v = 10$

LED Driver

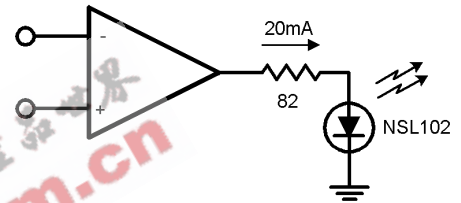

20007609

Fixed Current Sources

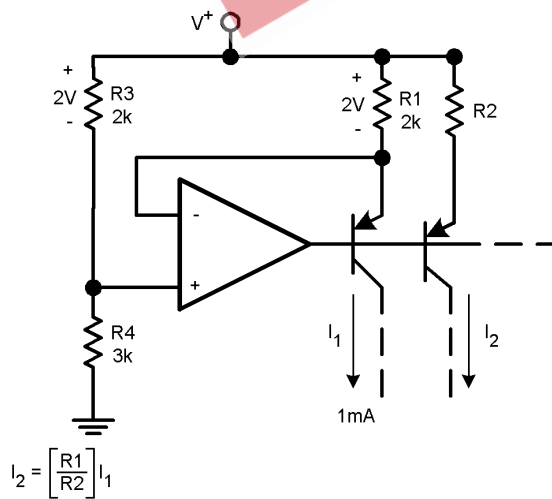

$$I_2 = \left[\frac{R_1}{R_2} \right] I_1$$

20007610

Lamp Driver

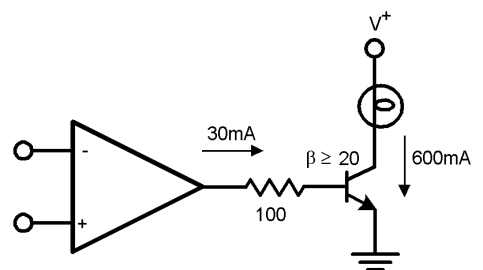

20007611

SOT23-5 Tape and Reel Specification

TAPE DIMENSIONS

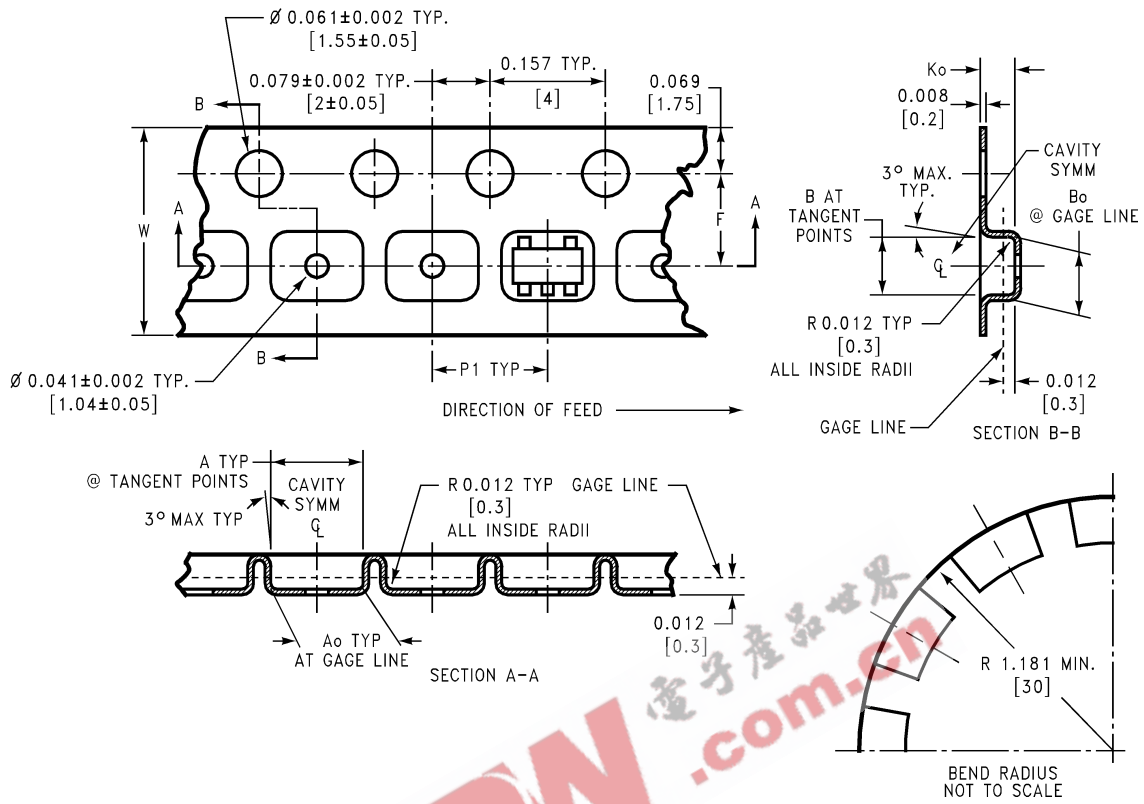

20007615

8mm	0.130 (3.3)	0.124 (3.15)	0.130 (3.3)	0.126 (3.2)	0.138 ± 0.002 (3.5 ± 0.05)	0.055 ± 0.004 (1.4 ± 0.11)	0.157 (4)	0.315 ± 0.012 (8 ± 0.3)
Tape Size	DIM A	DIM A _o	DIM B	DIM B _o	DIM F	DIM K _o	DIM P1	DIM W

SOT23-5 Tape and Reel Specification (Continued)

REEL DIMENSIONS

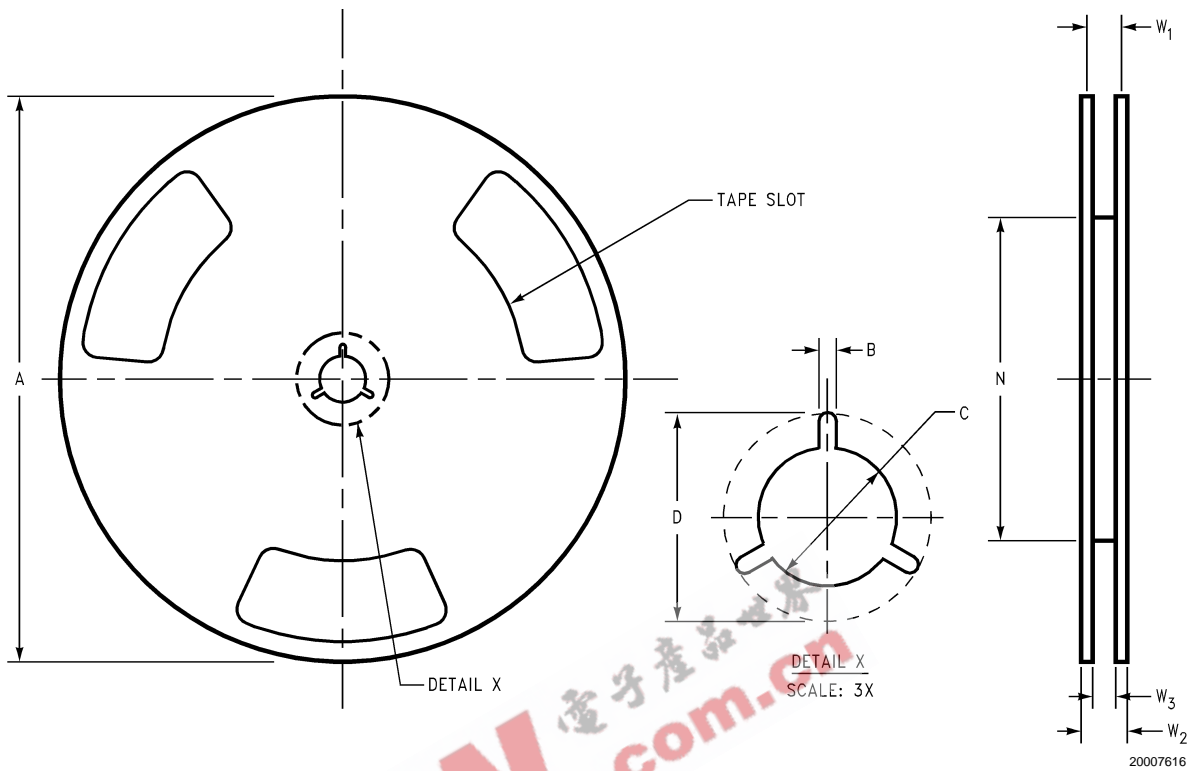

8mm	7.00 330.00	0.059 1.50	0.512 13.00	0.795 20.20	2.165 55.00	0.331 + 0.059/-0.000 8.40 + 1.50/-0.00	0.567 14.40	W1 + 0.078/-0.039 W1 + 2.00/-1.00
Tape Size	A	B	C	D	N	W1	W2	W3

Physical Dimensions inches (millimeters) unless otherwise noted

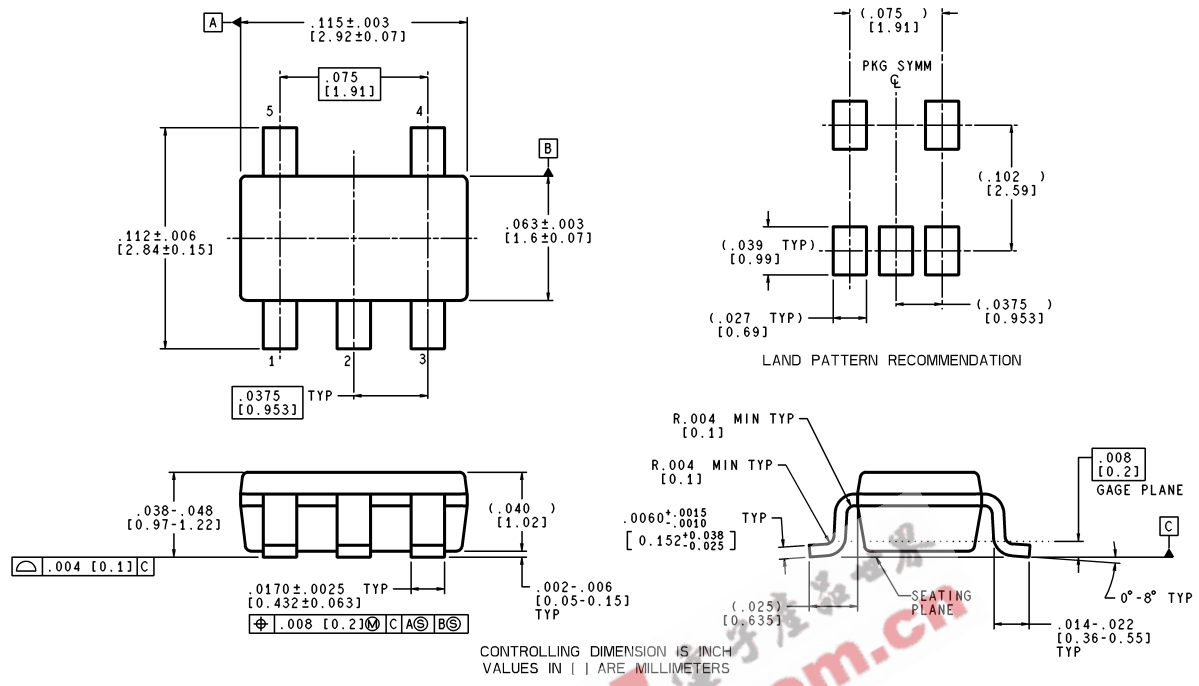

MF05A (Rev A)

5-Pin SOT23
NS Package Number MF05A

LIFE SUPPORT POLICY

NATIONAL'S PRODUCTS ARE NOT AUTHORIZED FOR USE AS CRITICAL COMPONENTS IN LIFE SUPPORT DEVICES OR SYSTEMS WITHOUT THE EXPRESS WRITTEN APPROVAL OF THE PRESIDENT AND GENERAL COUNSEL OF NATIONAL SEMICONDUCTOR CORPORATION. As used herein:

1. Life support devices or systems are devices or systems which, (a) are intended for surgical implant into the body, or (b) support or sustain life, and whose failure to perform when properly used in accordance with instructions for use provided in the labeling, can be reasonably expected to result in a significant injury to the user.
2. A critical component is any component of a life support device or system whose failure to perform can be reasonably expected to cause the failure of the life support device or system, or to affect its safety or effectiveness.

National Semiconductor Corporation
Americas
Tel: 1-800-272-9959
Fax: 1-800-737-7018
Email: support@nsc.com
www.national.com

National Semiconductor Europe
Fax: +49 (0) 180-530 85 86
Email: europe.support@nsc.com
Deutsch Tel: +49 (0) 69 9508 6208
English Tel: +44 (0) 870 24 0 2171
Français Tel: +33 (0) 1 41 91 8790

National Semiconductor Asia Pacific Customer Response Group
Tel: 65-2544466
Fax: 65-2504466
Email: ap.support@nsc.com

National Semiconductor Japan Ltd.
Tel: 81-3-5639-7560
Fax: 81-3-5639-7507