

# LM339, LM339A, LM239, LM239A, LM2901, M2901V, MC3302

## Quad Single Supply Comparators

These comparators are designed for use in level detection, low-level sensing and memory applications in consumer automotive and industrial electronic applications.

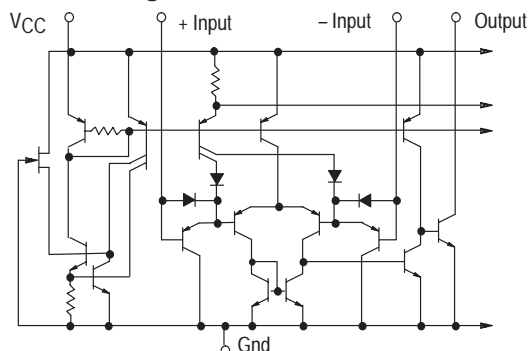
- Single or Split Supply Operation
- Low Input Bias Current: 25 nA (Typ)
- Low Input Offset Current:  $\pm 5.0$  nA (Typ)
- Low Input Offset Voltage:  $\pm 1.0$  mV (Typ) LM139A Series
- Input Common Mode Voltage Range to Gnd
- Low Output Saturation Voltage: 130 mV (Typ) @ 4.0 mA
- TTL and CMOS Compatible
- ESD Clamps on the Inputs Increase Reliability without Affecting Device Operation

### MAXIMUM RATINGS

Rating	Symbol	Value	Unit
Power Supply Voltage LM239, A/LM339A/LM2901, V MC3302	$V_{CC}$	+36 or $\pm 18$ +30 or $\pm 15$	Vdc
Input Differential Voltage Range LM239, A/LM339A/LM2901, V MC3302	$V_{IDR}$	36 30	Vdc
Input Common Mode Voltage Range	$V_{ICMR}$	-0.3 to $V_{CC}$	Vdc
Output Short Circuit to Ground (Note 1)	$I_{SC}$	Continuous	
Power Dissipation @ $T_A = 25^\circ\text{C}$ Plastic Package Derate above $25^\circ\text{C}$	PD	1.0 8.0	W mW/ $^\circ\text{C}$
Junction Temperature	$T_J$	150	$^\circ\text{C}$
Operating Ambient Temperature Range LM239, A MC3302 LM2901 LM2901V LM339, A	$T_A$	-25 to +85 -40 to +85 -40 to +105 -40 to +125 0 to +70	$^\circ\text{C}$
Storage Temperature Range	$T_{stg}$	-65 to +150	$^\circ\text{C}$

NOTE: 1. The maximum output current may be as high as 20 mA, independent of the magnitude of  $V_{CC}$ . Output short circuits to  $V_{CC}$  can cause excessive heating and eventual destruction.

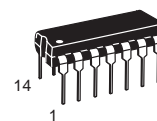
Figure 1. Circuit Schematic



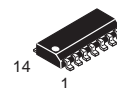
NOTE: Diagram shown is for 1 comparator.



**ON Semiconductor**  
Formerly a Division of Motorola  
<http://onsemi.com>

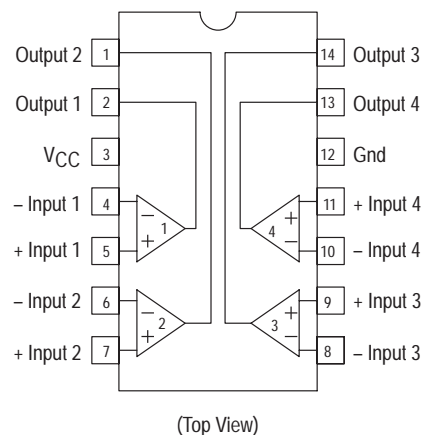


**N, P SUFFIX  
CASE 646**



**SO-14  
D SUFFIX  
CASE 751A**

### PIN CONNECTIONS



### ORDERING INFORMATION

See detailed ordering and shipping information in the package dimensions section on page 5 of this data sheet.

## LM339, LM339A, LM239, LM239A, LM2901, M2901V, MC3302

### ELECTRICAL CHARACTERISTICS ( $V_{CC} = +5.0$ Vdc, $T_A = +25^\circ\text{C}$ , unless otherwise noted)

Characteristic	Symbol	LM239A/339A			LM239/339			LM2901/2901V			MC3302			Unit
		Min	Typ	Max	Min	Typ	Max	Min	Typ	Max	Min	Typ	Max	
Input Offset Voltage (Note 4)	$V_{IO}$	-	$\pm 1.0$	$\pm 2.0$	-	$\pm 2.0$	$\pm 5.0$	-	$\pm 2.0$	$\pm 7.0$	-	$\pm 3.0$	$\pm 20$	mVdc
Input Bias Current (Notes 4, 5) (Output in Analog Range)	$I_{IB}$	-	25	250	-	25	250	-	25	250	-	25	500	nA
Input Offset Current (Note 4)	$I_{IO}$	-	$\pm 5.0$	$\pm 50$	-	$\pm 5.0$	$\pm 50$	-	$\pm 5.0$	$\pm 50$	-	$\pm 3.0$	$\pm 100$	nA
Input Common Mode Voltage Range	$V_{ICMR}$	0	-	$V_{CC} - 1.5$	0	-	$V_{CC} - 1.5$	0	-	$V_{CC} - 1.5$	0	-	$V_{CC} - 1.5$	V
Supply Current $R_L = \infty$ (For All Comparators) $R_L = \infty$ , $V_{CC} = 30$ Vdc	$I_{CC}$	-	0.8	2.0	-	0.8	2.0	-	0.8	2.0	-	0.8	2.0	mA
		-	1.0	2.5	-	1.0	2.5	-	1.0	2.5	-	1.0	2.5	
Voltage Gain $R_L \geq 15$ k $\Omega$ , $V_{CC} = 15$ Vdc	$A_{VOL}$	50	200	-	50	200	-	25	100	-	25	100	-	V/mV
Large Signal Response Time $V_I =$ TTL Logic Swing, $V_{ref} = 1.4$ Vdc, $V_{RL} = 5.0$ Vdc, $R_L = 5.1$ k $\Omega$	-	-	300	-	-	300	-	-	300	-	-	300	-	ns
Response Time (Note 6) $V_{RL} = 5.0$ Vdc, $R_L = 5.1$ k $\Omega$	-	-	1.3	-	-	1.3	-	-	1.3	-	-	1.3	-	$\mu\text{s}$
Output Sink Current $V_I (-) \geq +1.0$ Vdc, $V_I (+) = 0$ , $V_O \leq 1.5$ Vdc	$I_{Sink}$	6.0	16	-	6.0	16	-	6.0	16	-	6.0	16	-	mA
Saturation Voltage $V_I (-) \geq +1.0$ Vdc, $V_I (+) = 0$ , $I_{sink} \leq 4.0$ mA	$V_{sat}$	-	130	400	-	130	400	-	130	400	-	130	500	mV
Output Leakage Current $V_I (+) \geq +1.0$ Vdc, $V_I (-) = 0$ , $V_O = +5.0$ Vdc	$I_{OL}$	-	0.1	-	-	0.1	-	-	0.1	-	-	0.1	-	nA

### PERFORMANCE CHARACTERISTICS ( $V_{CC} = +5.0$ Vdc, $T_A = T_{low}$ to $T_{high}$ [Note 3])

Characteristic	Symbol	LM239A/339A			LM239/339			LM2901/2901V			MC3302			Unit
		Min	Typ	Max	Min	Typ	Max	Min	Typ	Max	Min	Typ	Max	
Input Offset Voltage (Note 4)	$V_{IO}$	-	-	$\pm 4.0$	-	-	$\pm 9.0$	-	-	$\pm 15$	-	-	$\pm 40$	mVdc
Input Bias Current (Notes 4, 5) (Output in Analog Range)	$I_{IB}$	-	-	400	-	-	400	-	-	500	-	-	1000	nA
Input Offset Current (Note 4)	$I_{IO}$	-	-	$\pm 150$	-	-	$\pm 150$	-	-	$\pm 200$	-	-	$\pm 300$	nA
Input Common Mode Voltage Range	$V_{ICMR}$	0	-	$V_{CC} - 2.0$	0	-	$V_{CC} - 2.0$	0	-	$V_{CC} - 2.0$	0	-	$V_{CC} - 2.0$	V
Saturation Voltage $V_I (-) \geq +1.0$ Vdc, $V_I (+) = 0$ , $I_{sink} \leq 4.0$ mA	$V_{sat}$	-	-	700	-	-	700	-	-	700	-	-	700	mV
Output Leakage Current $V_I (+) \geq +1.0$ Vdc, $V_I (-) = 0$ , $V_O = 30$ Vdc	$I_{OL}$	-	-	1.0	-	-	1.0	-	-	1.0	-	-	1.0	$\mu\text{A}$
Differential Input Voltage All $V_I \geq 0$ Vdc	$V_{ID}$	-	-	$V_{CC}$	-	-	$V_{CC}$	-	-	$V_{CC}$	-	-	$V_{CC}$	Vdc

NOTES: 3. (LM239/239A)  $T_{low} = -25^\circ\text{C}$ ,  $T_{high} = +85^\circ\text{C}$

(LM339/339A)  $T_{low} = 0^\circ\text{C}$ ,  $T_{high} = +70^\circ\text{C}$

(MC3302)  $T_{low} = -40^\circ\text{C}$ ,  $T_{high} = +85^\circ\text{C}$

(LM2901)  $T_{low} = -40^\circ\text{C}$ ,  $T_{high} = +105^\circ\text{C}$

(LM2901V)  $T_{low} = -40^\circ\text{C}$ ,  $T_{high} = +125^\circ\text{C}$

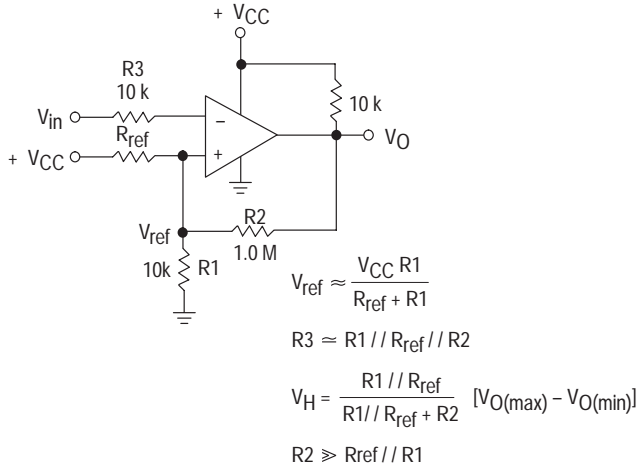
4. At the output switch point,  $V_O = 1.4$  Vdc,  $R_S \leq 100 \Omega$ ,  $5.0$  Vdc  $\leq V_{CC} \leq 30$  Vdc, with the inputs over the full common mode range (0 Vdc to  $V_{CC} - 1.5$  Vdc).

5. The bias current flows out of the inputs due to the PNP input stage. This current is virtually constant, independent of the output state.

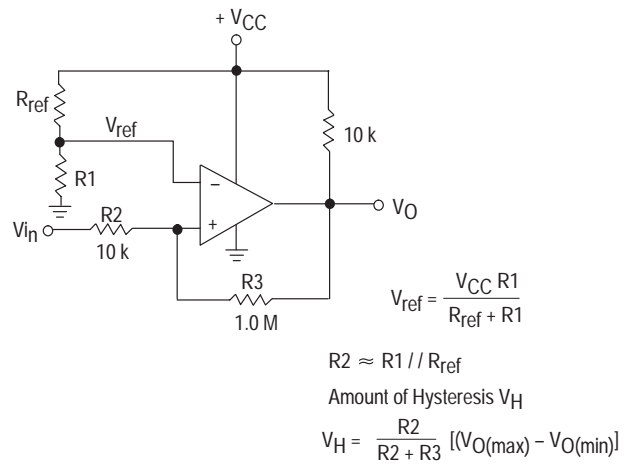
6. The response time specified is for a 100 mV input step with 5.0 mV overdrive. For larger signals, 300 ns is typical.

# LM339, LM339A, LM239, LM239A, LM2901, M2901V, MC3302

**Figure 2. Inverting Comparator with Hysteresis**



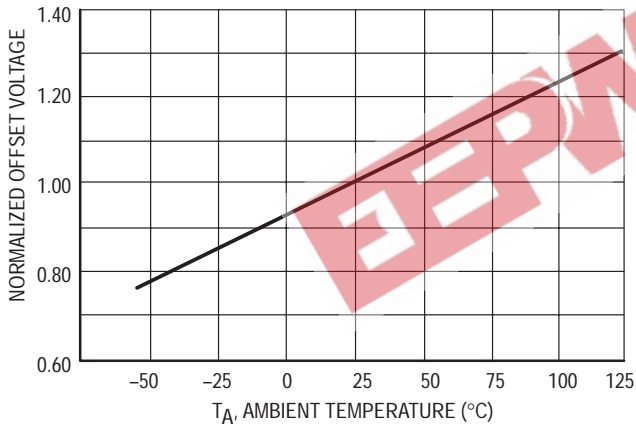
**Figure 3. Noninverting Comparator with Hysteresis**



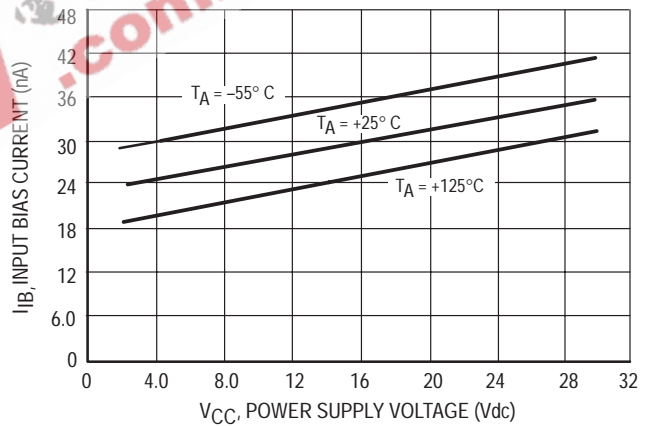
## Typical Characteristics

( $V_{CC} = 15 \text{ Vdc}$ ,  $T_A = +25^\circ\text{C}$  (each comparator) unless otherwise noted.)

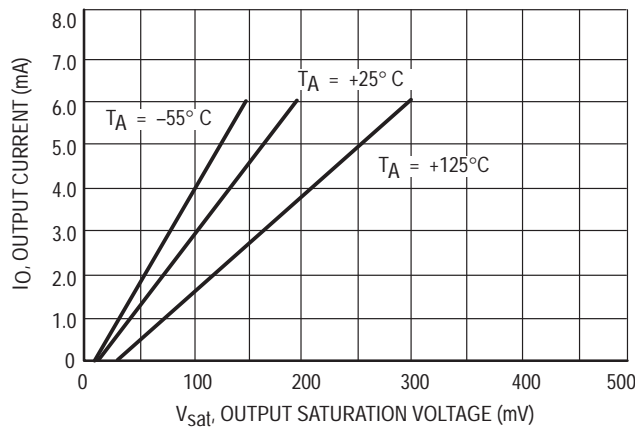
**Figure 4. Normalized Input Offset Voltage**



**Figure 5. Input Bias Current**

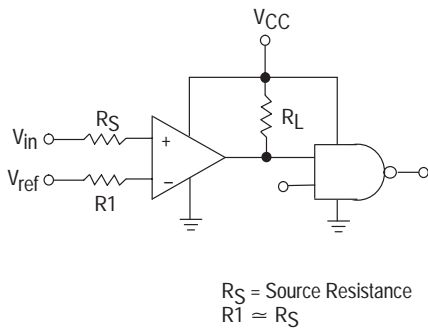


**Figure 6. Output Sink Current versus Output Saturation Voltage**



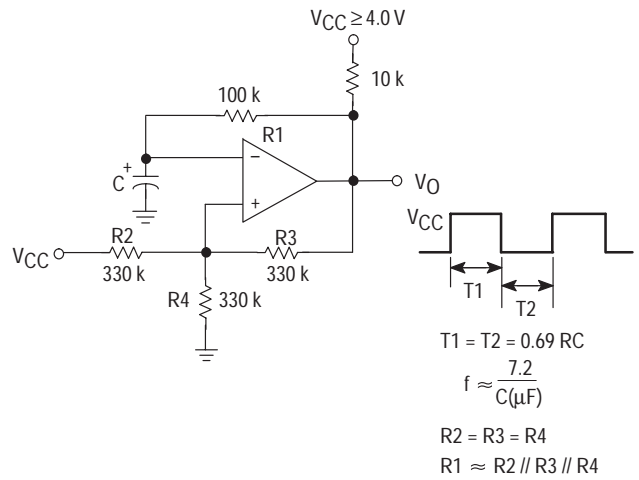
# LM339, LM339A, LM239, LM239A, LM2901, M2901V, MC3302

Figure 7. Driving Logic



Logic	Device	VCC (V)	RL kΩ
CMOS	1/4 MC14001	+15	100
TTL	1/4 MC7400	+5.0	10

Figure 8. Squarewave Oscillator



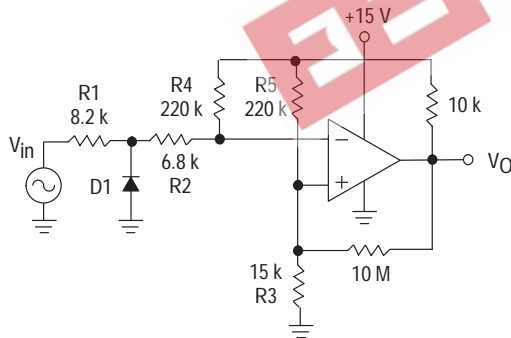
## APPLICATIONS INFORMATION

These quad comparators feature high gain, wide bandwidth characteristics. This gives the device oscillation tendencies if the outputs are capacitively coupled to the inputs via stray capacitance. This oscillation manifests itself during output transitions ( $V_{OL}$  to  $V_{OH}$ ). To alleviate this situation input resistors  $< 10 \text{ k}\Omega$  should be used. The

addition of positive feedback ( $< 10 \text{ mV}$ ) is also recommended. It is good design practice to ground all unused input pins.

Differential input voltages may be larger than supply voltages without damaging the comparator's inputs. Voltages more negative than  $-300 \text{ mV}$  should not be used.

Figure 9. Zero Crossing Detector (Single Supply)



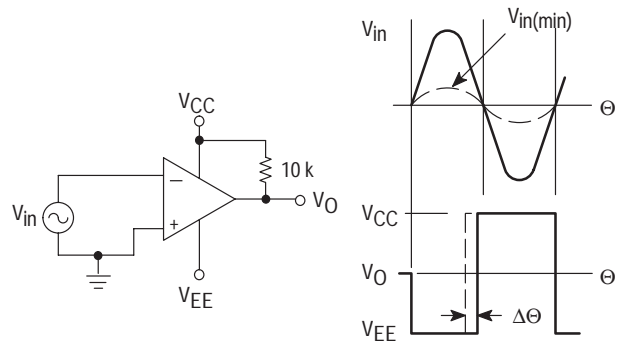
D1 prevents input from going negative by more than 0.6 V.

$$R_1 + R_2 = R_3$$

$$R_3 \leq \frac{R_5}{10} \text{ for small error in zero crossing}$$

Figure 10. Zero Crossing Detector (Split Supplies)

$$V_{in(min)} \approx 0.4 \text{ V peak for } 1\% \text{ phase distortion } (\Delta\theta).$$



## LM339, LM339A, LM239, LM239A, LM2901, M2901V, MC3302

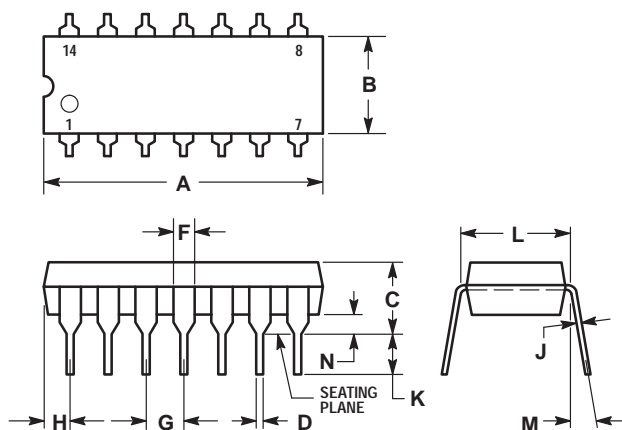
### ORDERING INFORMATION

Device	Package	Shipping
LM239D	SO-14	55 Units / Rail
LM239AD	SO-14	55 Units / Rail
LM239DR2	SO-14	2500 Units / Tape & Reel
LM239ADR2	SO-14	2500 Units / Tape & Reel
LM239N	DIP 14	25 Units / Rail
LM239AN	DIP 14	25 Units / Rail
LM339D	SO-14	55 Units / Rail
LM339AD	SO-14	55 Units / Rail
LM339DR2	SO-14	2500 Units / Tape & Reel
LM339ADR2	SO-14	2500 Units / Tape & Reel
LM339N	DIP 14	25 Units / Rail
LM339AN	DIP 14	25 Units / Rail
LM2901D	SO-14	55 Units / Rail
LM2901DR2	SO-14	2500 Units / Tape & Reel
LM2901N	DIP 14	25 Units / Rail
LM2901VD	SO-14	55 Units / Rail
LM2901VDR2	SO-14	2500 Units / Tape & Reel
LM2901VN	DIP 14	25 Units / Rail

# LM339, LM339A, LM239, LM239A, LM2901, M2901V, MC3302

## PACKAGE DIMENSIONS

N, P SUFFIX  
PLASTIC PACKAGE  
CASE 646-06  
ISSUE L



### NOTES:

- LEADS WITHIN 0.13 (0.005) RADIUS OF TRUE POSITION AT SEATING PLANE AT MAXIMUM MATERIAL CONDITION.
- DIMENSION L TO CENTER OF LEADS WHEN FORMED PARALLEL.
- DIMENSION B DOES NOT INCLUDE MOLD FLASH.
- ROUNDED CORNERS OPTIONAL.

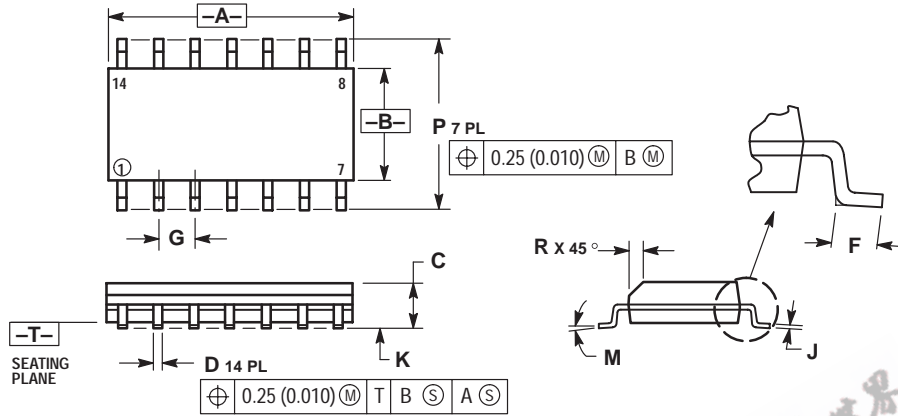
DIM	INCHES		MILLIMETERS	
	MIN	MAX	MIN	MAX
A	0.715	0.770	18.16	19.56
B	0.240	0.260	6.10	6.60
C	0.145	0.185	3.69	4.69
D	0.015	0.021	0.38	0.53
F	0.040	0.070	1.02	1.78
G	0.100 BSC		2.54 BSC	
H	0.052	0.095	1.32	2.41
J	0.008	0.015	0.20	0.38
K	0.115	0.135	2.92	3.43
L	0.300 BSC		7.62 BSC	
M	0°	10°	0°	10°
N	0.015	0.039	0.39	1.01

EEPW.com.cn 电子产品世界

LM339, LM339A, LM239, LM239A, LM2901, M2901V, MC3302

PACKAGE DIMENSIONS

D SUFFIX  
 PLASTIC PACKAGE  
 CASE 751A-03  
 (SO-14)  
 ISSUE F



NOTES:


1. DIMENSIONING AND TOLERANCING PER ANSI Y14.5M, 1982.
2. CONTROLLING DIMENSION: MILLIMETER.
3. DIMENSIONS A AND B DO NOT INCLUDE MOLD PROTRUSION.
4. MAXIMUM MOLD PROTRUSION 0.15 (0.006) PER SIDE.
5. DIMENSION D DOES NOT INCLUDE DAMBAR PROTRUSION. ALLOWABLE DAMBAR PROTRUSION SHALL BE 0.127 (0.005) TOTAL IN EXCESS OF THE D DIMENSION AT MAXIMUM MATERIAL CONDITION.

DIM	MILLIMETERS		INCHES	
	MIN	MAX	MIN	MAX
A	8.55	8.75	0.337	0.344
B	3.80	4.00	0.150	0.157
C	1.35	1.75	0.054	0.068
D	0.35	0.49	0.014	0.019
F	0.40	1.25	0.016	0.049
G	1.27 BSC		0.050 BSC	
J	0.19	0.25	0.008	0.009
K	0.10	0.25	0.004	0.009
M	0°		7°	
P	5.80	6.20	0.228	0.244
R	0.25	0.50	0.010	0.019



## LM339, LM339A, LM239, LM239A, LM2901, M2901V, MC3302

EEPW 电子產品世界  
.com.cn

**ON Semiconductor** and  are trademarks of Semiconductor Components Industries, LLC (SCILLC). SCILLC reserves the right to make changes without further notice to any products herein. SCILLC makes no warranty, representation or guarantee regarding the suitability of its products for any particular purpose, nor does SCILLC assume any liability arising out of the application or use of any product or circuit, and specifically disclaims any and all liability, including without limitation special, consequential or incidental damages. "Typical" parameters which may be provided in SCILLC data sheets and/or specifications can and do vary in different applications and actual performance may vary over time. All operating parameters, including "Typicals" must be validated for each customer application by customer's technical experts. SCILLC does not convey any license under its patent rights nor the rights of others. SCILLC products are not designed, intended, or authorized for use as components in systems intended for surgical implant into the body, or other applications intended to support or sustain life, or for any other application in which the failure of the SCILLC product could create a situation where personal injury or death may occur. Should Buyer purchase or use SCILLC products for any such unintended or unauthorized application, Buyer shall indemnify and hold SCILLC and its officers, employees, subsidiaries, affiliates, and distributors harmless against all claims, costs, damages, and expenses, and reasonable attorney fees arising out of, directly or indirectly, any claim of personal injury or death associated with such unintended or unauthorized use, even if such claim alleges that SCILLC was negligent regarding the design or manufacture of the part. SCILLC is an Equal Opportunity/Affirmative Action Employer.

### PUBLICATION ORDERING INFORMATION

#### USA/EUROPE Literature Fulfillment:

Literature Distribution Center for ON Semiconductor  
P.O. Box 5163, Denver, Colorado 80217 USA  
**Phone:** 303-675-2175 or 800-344-3860 Toll Free USA/Canada  
**Fax:** 303-675-2176 or 800-344-3867 Toll Free USA/Canada  
**Email:** ONlit@hibbertco.com

**Fax Response Line\*:** 303-675-2167  
800-344-3810 Toll Free USA/Canada  
\*To receive a Fax of our publications

**N. America Technical Support:** 800-282-9855 Toll Free USA/Canada

#### ASIA/PACIFIC: LDC for ON Semiconductor – Asia Support

**Phone:** 303-675-2121 (Tue–Fri 9:00am to 1:00pm, Hong Kong Time)  
**Email:** ONlit-asia@hibbertco.com

**JAPAN:** ON Semiconductor, Japan Customer Focus Center  
4-32-1 Nishi-Gotanda, Shinagawa-ku, Tokyo, Japan 141-8549

**Phone:** 81-3-5487-8345  
**Email:** r14153@onsemi.com

**ON Semiconductor Website:** <http://onsemi.com>

For additional information, please contact your local Sales Representative.