

# LM2479

## 120V Triple Bias Clamp

### General Description

The LM2479 is an Integrated 120V triple bias clamp circuit for DC recovery of each of the AC coupled outputs of a CRT driver. It is well matched with the DAC outputs of the LM126X family of pre-amplifiers. Each amplifier has its gain internally set to -18. The IC is packaged in an industry standard 8 lead molded DIP package.

- High input impedance
- Single supply operation
- Matched to the LM126X family of preamplifiers

### Recommended Applications

- CRT monitors requiring DC restoration at the cathodes

### Features

- Wide range integrated triple bias clamp

### Block Diagrams

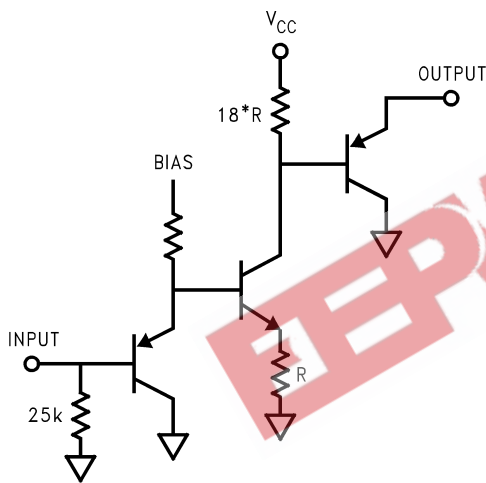

DS101391-1

FIGURE 1. Simplified Schematic (One Channel)

### Package Pinout

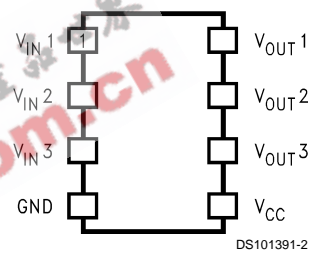

DS101391-2

FIGURE 2. LM2479 Package Pinout  
Order Number LM2479NA  
NS Package Number: N08E

**Absolute Maximum Ratings** (Note 1)

If Military/Aerospace specified devices are required, please contact the National Semiconductor Sales Office/Distributors for availability and specifications.

Supply Voltage, $V_{CC}$	+130V
Input Voltage, $V_{IN}$	0V to 5V
Storage Temperature Range, $T_{STG}$	-65°C to +150°C
Lead Temperature (Soldering, <10sec.)	300°C

ESD Tolerance, Machine Model

200V

**Limits of Operating Ranges** (Note 3)

$V_{CC}$	110 to 125
$V_{OUT}$ , $V_{CC} = 120V$	50 to 120V
Ambient Temperature Range, $T_A$	0 to 70°C

**DC CLAMP ELECTRICAL CHARACTERISTICS TARGETS AND LIMIT**

Unless otherwise noted:  $V_{CC} = +120V$ ,  $V_{IN} = 2.25V_{DC}$ ,  $T_A = 25^\circ C$ .

Symbol	Spec Parameter	Conditions	Min	Typ	Max	Units
$I_{CC}$	Supply Current	All channels		2.3	3.5	mA
$V_{OUT}$	DC Output Voltage		83	87	91	$V_{DC}$
$V_{OUT-Range}$	Output Voltage Range	$V_{IN}$ Range = 1.0V - 4.0V		53		V
$A_V$	DC Voltage Gain		-16	-18	-20	
LE	Linearity Error	See Note 1		5		%
$R_{IN}$	Input Resistance			24K		$\Omega$

**Note 1:** Linearity Error is the variation in DC gain from  $V_{IN} = 1.0V$  to  $V_{IN} = 4.0V$ .

**Note 2:** Absolute Maximum Ratings indicate limits beyond which damage to the device may occur.

**Note 3:** Operating Ratings indicate conditions for which the device is functional, but do not guarantee specific performance limits. For guaranteed specifications and the test conditions, see the Electrical Characteristics. The guaranteed specifications apply only for the test conditions listed. Some performance characteristics may change when the device is not operated under the listed test conditions.

**Note 4:** All voltages are measured with respect to GND, unless otherwise specified.

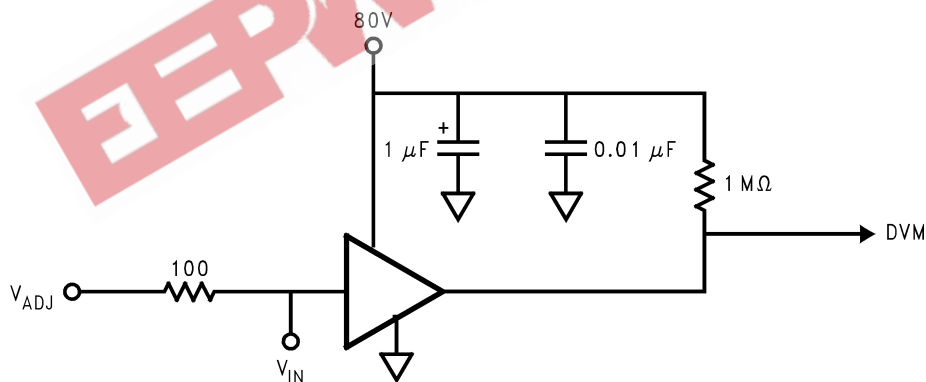
**Test Circuit**

DS101391-3

**FIGURE 3. Test Circuit (One Channel)**

Figure 3 shows the test circuit for evaluation of the LM2479 Clamp Amplifier. A high impedance VM (>100M $\Omega$ ) is used for DC measurements at the output.

## Typical Performance Characteristics

( $V_{CC} = +120V$ ), Test Circuit - Figure 3 unless otherwise specified.

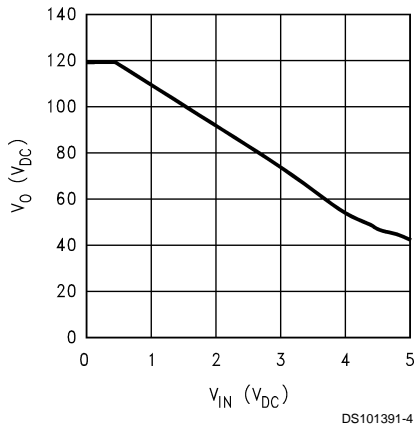

FIGURE 4.  $V_{out}$  vs  $V_{in}$

## THEORY OF OPERATION

The circuit diagram of the LM2479 is shown in Figure 1. The DC clamp circuit amplifies the input signal by -18 and the gain is set by the resistor ratio of  $18R$  and  $R$ . The output requires pull-up resistor to 120V. Figure 2 shows the test circuit used for evaluation of the LM2479 Clamp Amplifier. A high impedance voltmeter ( $100M\Omega$ ) is used for DC measurements at the output. The DC transfer function is shown in Figure 4.

## APPLICATION HINTS

### Power Supply Bypass

The LM2479 should have proper power supply bypassing for optimum performance. A  $0.1\mu F$  capacitor should be connected from the supply pin,  $V_{CC}$ , to ground, as close to the supply and ground pins as is practical. Additionally, a  $1.0\mu F$  electrolycelectrolytic capacitor should be connected from

the supply pin to ground. The electrolytic capacitor should also be placed reasonably close to the LM2479's supply and ground pins.

### Application Circuit

The application circuit shown in Figure 5 is designed to help clamp the voltage at the output of the driver to the desired level. Capacitor  $C_4$  stabilizes the entire node at the anode of the clamp diode,  $D_3$ , by creating a low impedance at high frequencies. Figure 5 also shows the standard application circuit topology when used with an LM246X CRT driver. It shows all the components necessary to optimize performance as well as to protect against damage from a CRT arc event. No additional components are required to protect the LM2479 from arc damage.

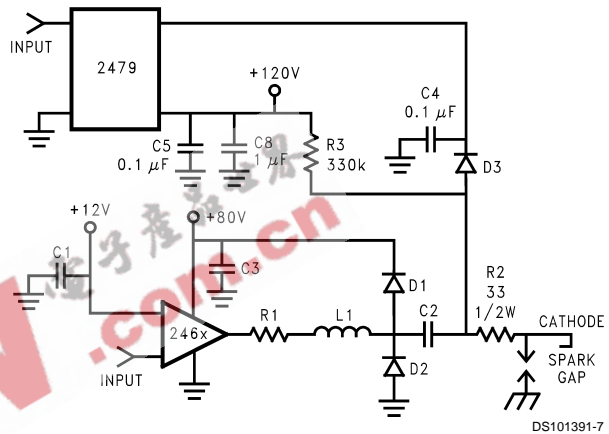
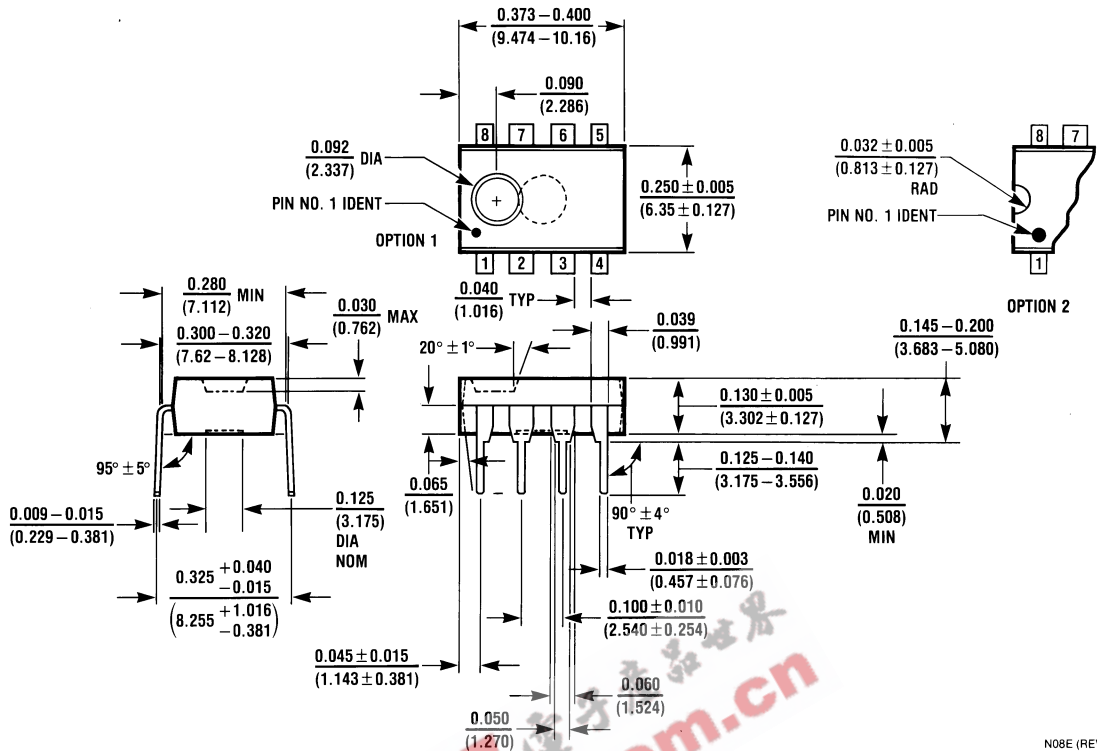

FIGURE 5. One Channel of the LM2479 and LM246X Application Circuit

### Demonstration Hardware

National Semiconductor has designed a demonstration neckboard for the LM126X, LM246X, and the LM2479 chipset. To obtain demonstration boards contact the National Semiconductor Sales Office in your region.

**Physical Dimensions** inches (millimeters) unless otherwise noted



Note: Information contained in this data sheet is preliminary and may be subject to change without notice.

**Molded Dual-In-Line Package (N)**  
**NS Package Number N08E**  
**Order Number LM2479NA**

**LIFE SUPPORT POLICY**

NATIONAL'S PRODUCTS ARE NOT AUTHORIZED FOR USE AS CRITICAL COMPONENTS IN LIFE SUPPORT DEVICES OR SYSTEMS WITHOUT THE EXPRESS WRITTEN APPROVAL OF THE PRESIDENT AND GENERAL COUNSEL OF NATIONAL SEMICONDUCTOR CORPORATION. As used herein:

1. Life support devices or systems are devices or systems which, (a) are intended for surgical implant into the body, or (b) support or sustain life, and whose failure to perform when properly used in accordance with instructions for use provided in the labeling, can be reasonably expected to result in a significant injury to the user.
2. A critical component is any component of a life support device or system whose failure to perform can be reasonably expected to cause the failure of the life support device or system, or to affect its safety or effectiveness.

**National Semiconductor Corporation**  
 Americas  
 Tel: 1-800-272-9959  
 Fax: 1-800-737-7018  
 Email: support@nsc.com  
 www.national.com

**National Semiconductor Europe**  
 Fax: +49 (0) 180-530 85 86  
 Email: europe.support@nsc.com  
 Deutsch Tel: +49 (0) 69 9508 6208  
 English Tel: +44 (0) 870 24 0 2171  
 Français Tel: +33 (0) 1 41 91 8790

**National Semiconductor Asia Pacific Customer Response Group**  
 Tel: 65-2544466  
 Fax: 65-2504466  
 Email: ap.support@nsc.com

**National Semiconductor Japan Ltd.**  
 Tel: 81-3-5639-7560  
 Fax: 81-3-5639-7507