

LM2422 220V Monolithic Triple Channel 30 MHz CRT DTV Driver

General Description

The LM2422 is a triple channel high voltage CRT driver circuit designed for use in DTV applications. The IC contains three high input impedance, wide band amplifiers which directly drive the RGB cathodes of a CRT. Each channel has its gain internally set to -52 and can drive CRT capacitive loads as well as resistive loads present in other applications, limited only by the package's power dissipation.

The IC is packaged in an industry standard 11-lead TO-220 molded plastic power package designed specifically to meet high voltage spacing requirements. See Thermal Considerations section.

Features

- 30 MHz bandwidth
- Greater than $130V_{P-P}$ output swing capability
- 0V to 5V input voltage range
- Stable with 0 pF–20 pF capacitive loads and inductive peaking networks
- Convenient TO-220 staggered thin lead package style

Applications

- HDTV applications using the 1080i format as well as other DTV and standard TV formats.

Connection Diagram

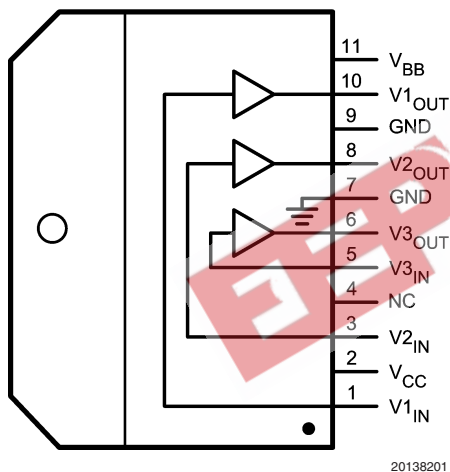

FIGURE 1. Top View
Order Number LM2422
See NS Package Number TE11B

Schematic Diagram

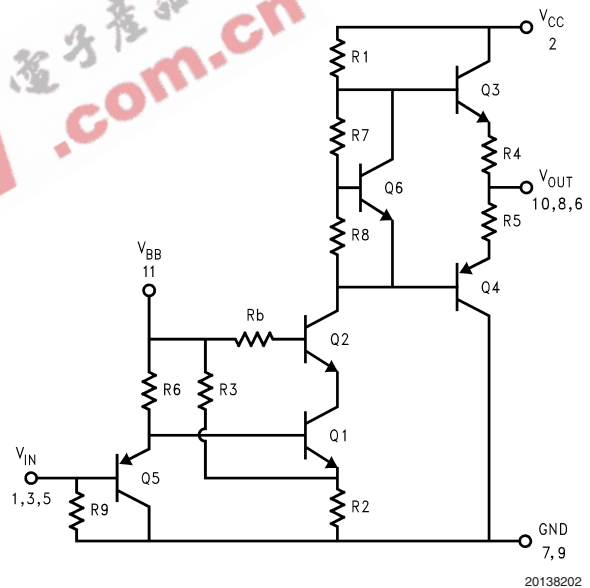

FIGURE 2. Simplified Schematic Diagram
(One Channel)

Absolute Maximum Ratings (Notes 1, 3)

If Military/Aerospace specified devices are required, please contact the National Semiconductor Sales Office/Distributors for availability and specifications.

Supply Voltage (V_{CC})	+250V
Bias Voltage (V_{BB})	+16V
Input Voltage (V_{IN})	-0.5V to V_{BB} +0.5V
Storage Temperature Range (T_{STG})	-65°C to +150°C
Lead Temperature (Soldering, <10 sec.)	300°C
ESD Tolerance, Human Body Model	2 kV
Machine Model	200V
Junction Temperature	150°C
θ_{JC} (typ)	1.8°C/W

Operating Ratings (Note 2)

V_{CC}	+100V to +230V
V_{BB}	+7V to +13V
V_{IN}	+0V to +5V
V_{OUT}	+40V to +215V
Case Temperature (22W max power)	110°C

Do not operate the part without a heat sink. Heat sink must have a thermal resistance under 2.3°C/W. (Note 7)

Electrical Characteristics

(See Figure 3 for Test Circuit). Unless otherwise noted: $V_{CC} = +220V$, $V_{BB} = +12V$, $C_L = 10$ pF, $T_C = 60^\circ\text{C}$. DC Tests: $V_{IN} = +2.7V_{DC}$. AC Tests: Output = 110V_{PP} (80V – 190V) at 1 MHz.

Symbol	Parameter	Conditions	LM2422			Units
			Min	Typ	Max	
I_{CC}	Supply Current	No Input Signal, No Video Input, No Output Load	36	45	54	mA
I_{BB}	Bias Current		18	27	36	mA
$V_{OUT,1}$	DC Output Voltage	No AC Input Signal, $V_{IN} = 2.7V_{DC}$	124	129	134	V_{DC}
$V_{OUT,2}$	DC Output Voltage	No AC Input Signal, $V_{IN} = 1.2V_{DC}$	200	205	210	V_{DC}
A_V	DC Voltage Gain	No AC Input Signal	-49	-52	-55	V/V
ΔA_V	Gain Matching	(Note 4), No AC Input Signal		1.0		dB
LE	Linearity Error	(Notes 4, 5), No AC Input Signal		8		%
t_r	Rise Time, 80V to 190V	(Note 6), 10% to 90%		12		ns
+OS	Overshoot			12		%
t_f	Fall Time, 80V to 190V	(Note 6), 90% to 10%		12		ns
-OS	Overshoot	(Note 6)		4		%

Note 1: Absolute Maximum Ratings indicate limits beyond which damage to the device may occur.

Note 2: Operating ratings indicate conditions for which the device is functional, but do not guarantee specific performance limits. For guaranteed specifications and test conditions, see the Electrical Characteristics. Datasheet min/max specification limits are guaranteed by design, test, or statistical analysis. The guaranteed specifications apply only for the test conditions listed. Some performance characteristics may change when the device is not operated under the listed test conditions.

Note 3: All voltages are measured with respect to GND, unless otherwise specified.

Note 4: Calculated value from Voltage Gain test on each channel.

Note 5: Linearity Error is the variation in DC gain from $V_{IN} = 1.15V$ to $V_{IN} = 4.35V$.

Note 6: Input from signal generator: $t_r, t_f < 1$ ns.

Note 7: Running the 1 MHz to 30 MHz test pattern at 1080i this part will dissipate approximately 22 W. This is the commonly accepted test pattern that is representative of the worst case high frequency content for normal television viewing. This is the pattern used to estimate the worst case power dissipation of the LM2422 in its normal application. It is recommended to use a heat sink with a thermal resistance of 2.3°C/W or better.

AC Test Circuit

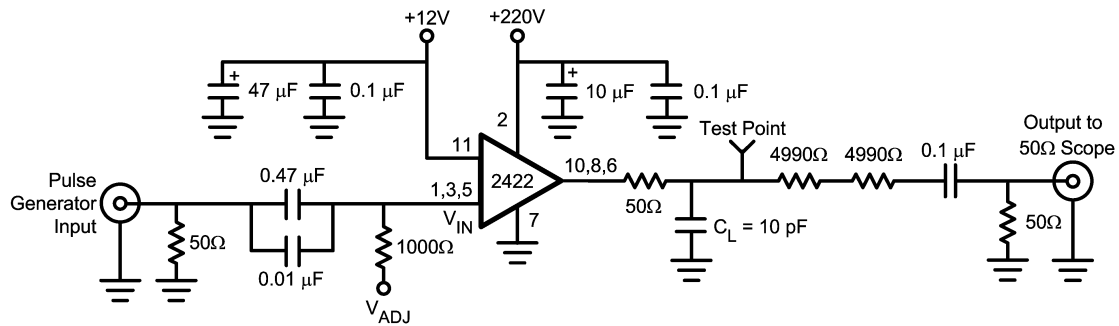

Note: 10 pF load includes parasitic capacitance.

20138203

FIGURE 3. Test Circuit (One Channel)

Figure 3 shows a typical test circuit for evaluation of the LM2422. This circuit is designed to allow testing of the LM2422 in a 50Ω environment without the use of an expensive FET probe. The two 4990Ω resistors form a 400:1 divider with the 50Ω resistor and the oscilloscope. A test point is included for easy use of an oscilloscope probe. The compensation capacitor is used to compensate the network to achieve flat frequency response.

EEPW 电子产品世界
www.eepw.com.cn

Typical Performance Characteristics ($V_{CC} = +220V_{DC}$, $V_{BB} = +12V_{DC}$, $C_L = 10\text{ pF}$, $V_{OUT} = 110V_{PP}$ (80V – 190V), $T_C = 60^\circ\text{C}$, Test Circuit— Figure 3 unless otherwise specified)

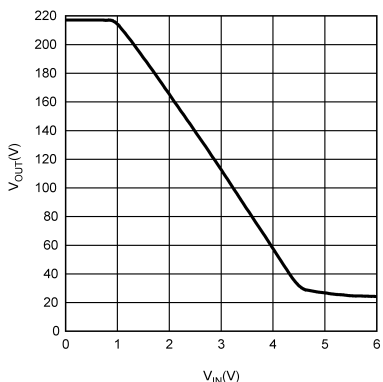

20138204

FIGURE 4. V_{OUT} vs V_{IN}

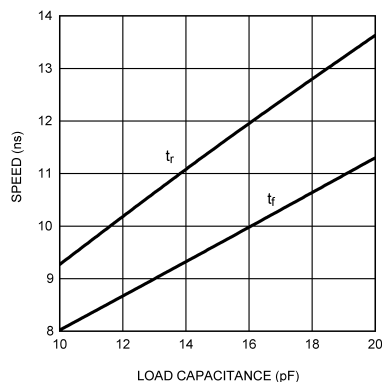

20138207

FIGURE 7. Speed vs Load Capacitance

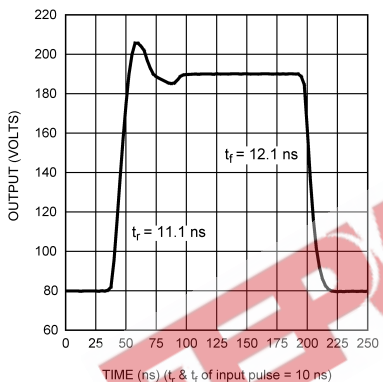

20138205

FIGURE 5. LM2422 Pulse Response

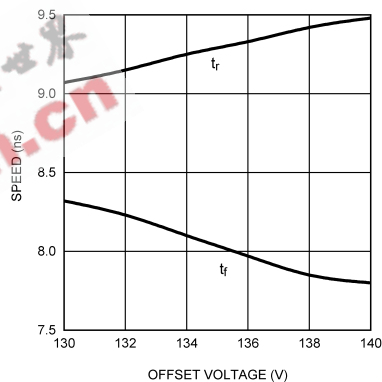

20138208

FIGURE 8. Speed vs Offset

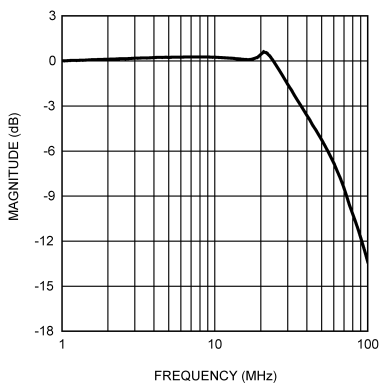

20138206

FIGURE 6. Bandwidth

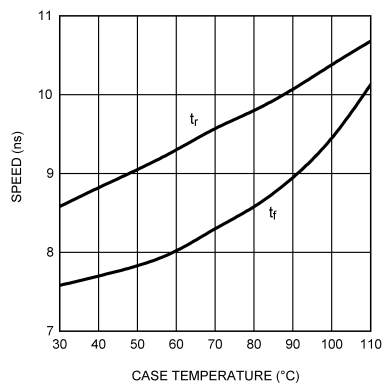

20138209

FIGURE 9. Speed vs Case Temperature

Typical Performance Characteristics ($V_{CC} = +220V_{DC}$, $V_{BB} = +12V_{DC}$, $C_L = 10\text{ pF}$, $V_{OUT} = 110V_{PP}$ (80V – 190V), $T_C = 60^\circ\text{C}$, Test Circuit—*Figure 3* unless otherwise specified)

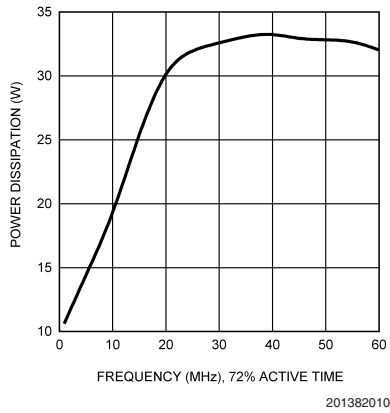

FIGURE 10. Power Dissipation vs Frequency

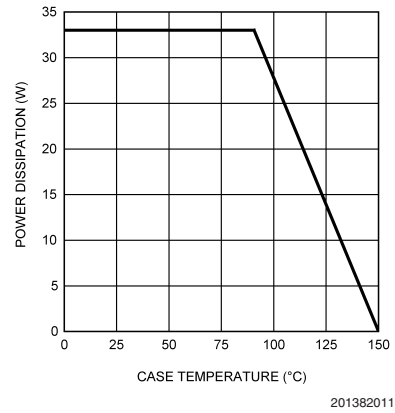

FIGURE 11. Safe Operating Area

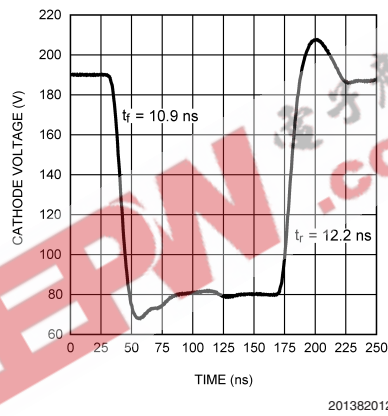

FIGURE 12. LM2422 Cathode Response

Theory of Operation

The LM2422 is a high voltage monolithic three channel CRT driver suitable for DTV applications. The LM2422 operates with 220V and 12V power supplies. The part is housed in the industry standard 11-lead TO-220 molded plastic power package with thin leads for improved metal-to-metal spacing.

The circuit diagram of the LM2422 is shown in *Figure 2*. The PNP emitter follower, Q5, provides input buffering. Q1 and Q2 form a fixed gain cascode amplifier with resistors R1 and R2 setting the gain at -52 . Emitter followers Q3 and Q4 isolate the high output impedance of the cascode stage from the capacitance of the CRT cathode, which decreases the sensitivity of the device to load capacitance. Q6 provides biasing to the output emitter follower stage to reduce cross-over distortion at low signal levels.

Figure 3 shows a typical test circuit for evaluation of the LM2422. This circuit is designed to allow testing of the LM2422 in a 50Ω environment without the use of an expensive FET probe. In this test circuit, the two $4.99\text{ k}\Omega$ resistors form a 400:1 wideband, low capacitance probe when connected to a 50Ω coaxial cable and a 50Ω load (such as a 50Ω oscilloscope input). The input signal from the generator is ac coupled to the base of Q5.

Application Hints

INTRODUCTION

National Semiconductor (NSC) is committed to provide application information that assists our customers in obtaining the best performance possible from our products. The following information is provided in order to support this commitment. The reader should be aware that the optimization of performance was done using a specific printed circuit board designed at NSC. Variations in performance can be realized due to physical changes in the printed circuit board and the application. Therefore, the designer should know that component value changes may be required in order to optimize performance in a given application. The values shown in this document can be used as a starting point for evaluation purposes. When working with high bandwidth circuits, good layout practices are also critical to achieving maximum performance.

IMPORTANT INFORMATION

The LM2422 performance is targeted for the HDTV market. The application circuits shown in this document to optimize performance and to protect against damage from CRT arc over are designed specifically for the LM2422. If another member of the LM242X family is used, please refer to its datasheet.

POWER SUPPLY BYPASS

Since the LM2422 is a wide bandwidth amplifier, proper power supply bypassing is critical for optimum performance. Improper power supply bypassing can result in large overshoot, ringing or oscillation. $0.1\ \mu\text{F}$ capacitors should be connected from the supply pins, V_{CC} and V_{BB} , to ground, as close to the LM2422 as is practical. Additionally, a $22\ \mu\text{F}$ or larger electrolytic capacitor should be connected from both supply pins to ground reasonably close to the LM2422.

ARC PROTECTION

During normal CRT operation, internal arcing may occasionally occur. This fast, high voltage, high-energy pulse can damage the LM2422 output stage. The application circuit

shown in *Figure 13* is designed to help clamp the voltage at the output of the LM2422 to a safe level. The clamp diodes, D1 and D2, should have a fast transient response, high peak current rating, low series impedance and low shunt capacitance. 1SS83 or equivalent diodes are recommended. D1 and D2 should have short, low impedance connections to V_{CC} and ground respectively. The cathode of D1 should be located very close to a separately decoupled bypass capacitor (C3 in *Figure 13*). The ground connection of D2 and the decoupling capacitor should be very close to the LM2422 ground. This will significantly reduce the high frequency voltage transients that the LM2422 would be subjected to during an arc over condition. Resistor R2 limits the arc over current that is seen by the diodes while R1 limits the current into the LM2422 as well as the voltage stress at the outputs of the device. R2 should be a $\frac{1}{2}\text{W}$ solid carbon type resistor. R1 can be a $\frac{1}{4}\text{W}$ metal or carbon film type resistor. Having large value resistors for R1 and R2 would be desirable, but this has the effect of increasing rise and fall times. Inductor L1 is critical to reduce the initial high frequency voltage levels that the LM2422 would be subjected to. The inductor will not only help protect the device but it will also help minimize rise and fall times as well as minimize EMI. For proper arc protection, it is important to not omit any of the arc protection components shown in *Figure 13*.

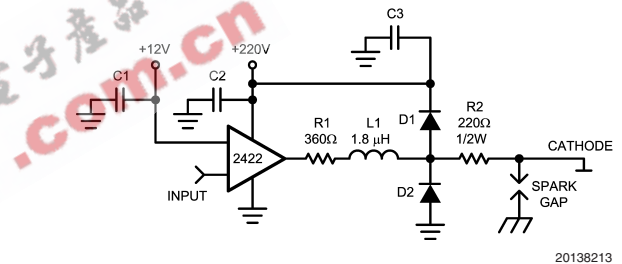

FIGURE 13. One Channel of the LM2422 with the Recommended Application Circuit

EFFECT OF LOAD CAPACITANCE

Figure 7 shows the effect of increased load capacitance on the speed of the device. This demonstrates the importance of knowing the load capacitance in the application. Increasing the load capacitance from $10\ \text{pF}$ to $20\ \text{pF}$ adds about $4.5\ \text{ns}$ to the rise time and $3.5\ \text{ns}$ to the fall time. It is important to keep the board capacitance as low as possible to maximize the speed of the driver.

EFFECT OF OFFSET

Figure 8 shows the variation in rise and fall times when the output offset of the device is varied from 120V to 130V_{DC} . Offset has little effect on the LM2422. The rise time increases less than $0.5\ \text{ns}$ as the offset is increased in voltage and the fall time decreases by about $0.5\ \text{ns}$ with the same offset adjustment.

THERMAL CONSIDERATIONS

Figure 9 shows the performance of the LM2422 in the test circuit shown in *Figure 3* as a function of case temperature. The figure shows that the rise time of the LM2422 increases by about $2\ \text{ns}$ as the case temperature increases from 30°C to 110°C . Over the same case temperature range the fall time increased by about $2.5\ \text{ns}$.

Application Hints (Continued)

Figure 10 shows the maximum power dissipation of the LM2422 vs. Frequency when all three channels of the device are driving into a 10 pF load with a 110V_{P-P} alternating one pixel on, one pixel off. Note that the frequency given in Figure 10 is half of the pixel frequency. The graph assumes a 72% active time (device operating at the specified frequency), which is typical in a TV application. The other 28% of the time the device is assumed to be sitting at the black level (190V in this case). A TV picture will not have frequency content over the whole picture exceeding 20 MHz. It is important to establish the worst case condition under normal viewing to give a realistic worst-case power dissipation for the LM2422. One test is a 1 to 30 MHz sine wave sweep over the active line. This would give a slightly lower power than taking the average of the power between 1 and 30 MHz. This average is 23.5 W. A sine wave will dissipate slightly less power, probably about 21 W or 22 W of power dissipation. All of this information is critical for the designer to establish the heat sink requirement for his application. The designer should note that if the load capacitance is increased the AC component of the total power dissipation will also increase.

The LM2422 case temperature must be maintained below 110°C given the maximum power dissipation estimate of 22W. If the maximum expected ambient temperature is 60°C and the maximum power dissipation is 22W then a maximum heat sink thermal resistance can be calculated:

$$R_{TH} = \frac{110^{\circ}\text{C} - 60^{\circ}\text{C}}{22\text{W}} = 2.3^{\circ}\text{C/W}$$

This example assumes a capacitive load of 10 pF and no resistive load. The designer should note that if the load capacitance is increased the AC component of the total power dissipation will also increase.

OPTIMIZING TRANSIENT RESPONSE

Referring to Figure 13, there are three components (R1, R2 and L1) that can be adjusted to optimize the transient response of the application circuit. Increasing the values of R1 and R2 will slow the circuit down while decreasing overshoot. Increasing the value of L1 will speed up the circuit as well as increase overshoot. It is very important to use inductors with very high self-resonant frequencies, preferably above 300 MHz. Ferrite core inductors from J.W. Miller Magnetics (part # 78FR--K) were used for optimizing the

performance of the device in the NSC application board. The values shown in Figure 13 can be used as a good starting point for the evaluation of the LM2422. Using a variable resistor for R1 will simplify finding the value needed for optimum performance in a given application. Once the optimum value is determined the variable resistor can be replaced with a fixed value. Due to arc over considerations it is recommended that the values shown in Figure 13 not be changed by a large amount.

Figure 12 shows the typical cathode pulse response with an output swing of 110V_{PP} inside a modified production TV set using the LM1237 pre-amp.

PC BOARD LAYOUT CONSIDERATIONS

For optimum performance, an adequate ground plane, isolation between channels, good supply bypassing and minimizing unwanted feedback are necessary. Also, the length of the signal traces from the signal inputs to the LM2422 and from the LM2422 to the CRT cathode should be as short as possible. The following references are recommended:

Ott, Henry W., "Noise Reduction Techniques in Electronic Systems", John Wiley & Sons, New York, 1976.

"Video Amplifier Design for Computer Monitors", National Semiconductor Application Note 1013.

Pease, Robert A., "Troubleshooting Analog Circuits", Butterworth-Heinemann, 1991.

Because of its high small signal bandwidth, the part may oscillate in a TV if feedback occurs around the video channel through the chassis wiring. To prevent this, leads to the video amplifier input circuit should be shielded, and input circuit wiring should be spaced as far as possible from output circuit wiring.

TYPICAL APPLICATION

The typical application for the LM2422 is in HDTV systems with scan rates as high as 1080i. Full resolution of a 1080i system requires 30 MHz of bandwidth matching the capability of the LM2422. Used in conjunction with an AVP with a 1.2V black level output no buffer transistors are required to obtain the correct black level at the cathodes. If the AVP has a black level closer to 2V, then an NPN transistor should be used to drop the video black level voltage closer to 1.2V. Some AVPs have black levels at about 2.5V. This level would require two buffer transistors to drop the black level to the desired 1.2V. For more information on typical applications or for demonstration boards please contact your local National Semiconductor representative.

Physical Dimensions inches (millimeters) unless otherwise noted

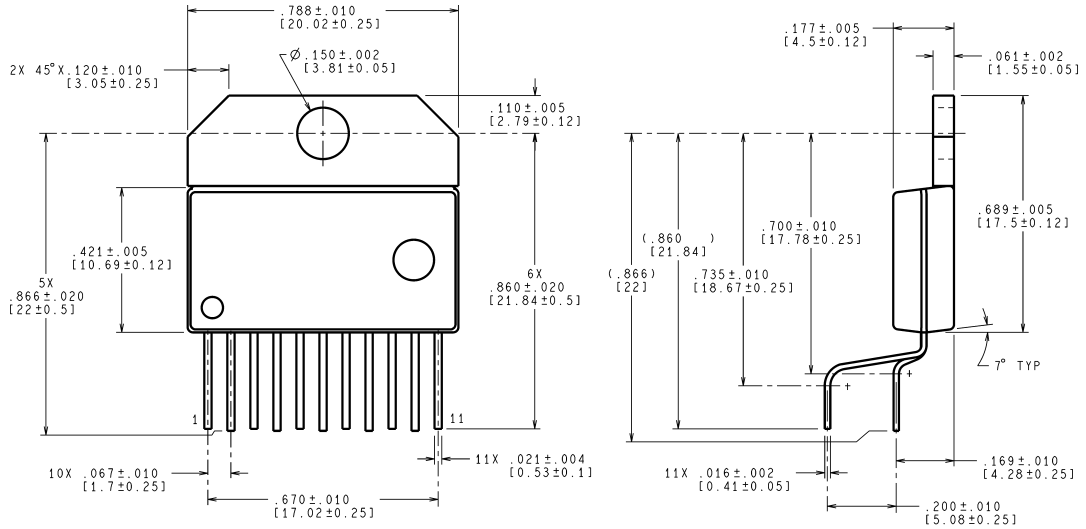

CONTROLLING DIMENSION IS INCH
VALUES IN [] ARE MILLIMETERS

TE11B (Rev A)

NOTE: Available only with lead free plating

NS Package Number TE11B
Order Number LM2422

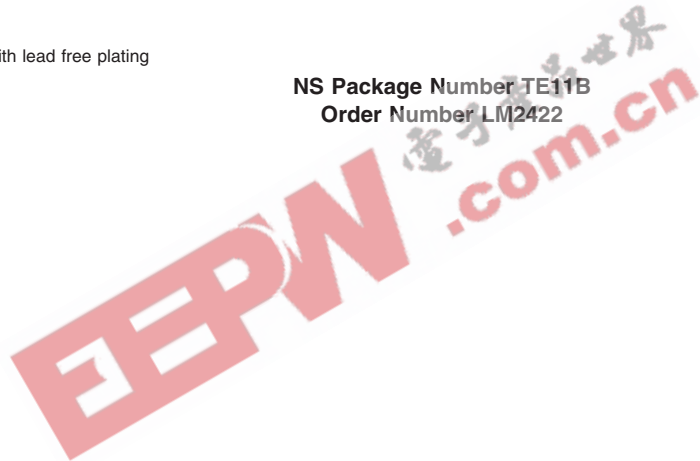

National does not assume any responsibility for use of any circuitry described, no circuit patent licenses are implied and National reserves the right at any time without notice to change said circuitry and specifications.

For the most current product information visit us at www.national.com.

LIFE SUPPORT POLICY

NATIONAL'S PRODUCTS ARE NOT AUTHORIZED FOR USE AS CRITICAL COMPONENTS IN LIFE SUPPORT DEVICES OR SYSTEMS WITHOUT THE EXPRESS WRITTEN APPROVAL OF THE PRESIDENT AND GENERAL COUNSEL OF NATIONAL SEMICONDUCTOR CORPORATION. As used herein:

1. Life support devices or systems are devices or systems which, (a) are intended for surgical implant into the body, or (b) support or sustain life, and whose failure to perform when properly used in accordance with instructions for use provided in the labeling, can be reasonably expected to result in a significant injury to the user.
2. A critical component is any component of a life support device or system whose failure to perform can be reasonably expected to cause the failure of the life support device or system, or to affect its safety or effectiveness.

BANNED SUBSTANCE COMPLIANCE

National Semiconductor manufactures products and uses packing materials that meet the provisions of the Customer Products Stewardship Specification (CSP-9-111C2) and the Banned Substances and Materials of Interest Specification (CSP-9-111S2) and contain no "Banned Substances" as defined in CSP-9-111S2.

Leadfree products are RoHS compliant.



National Semiconductor
Americas Customer
Support Center
Email: new.feedback@nsc.com
Tel: 1-800-272-9959

National Semiconductor
Europe Customer Support Center
Fax: +49 (0) 180-530 85 86
Email: europe.support@nsc.com
Deutsch Tel: +49 (0) 69 9508 6208
English Tel: +44 (0) 870 24 0 2171
Français Tel: +33 (0) 1 41 91 8790

National Semiconductor
Asia Pacific Customer
Support Center
Email: ap.support@nsc.com

National Semiconductor
Japan Customer Support Center
Fax: 81-3-5639-7507
Email: jpn.feedback@nsc.com
Tel: 81-3-5639-7560