

Dual voltage comparator

LM219/319

DESCRIPTION

The LM319 series are precision high-speed dual comparators fabricated on a single monolithic chip. They are designed to operate over a wide range of supply voltages down to a single 5V logic supply and ground. Further, they have higher gain and lower input currents than devices like the μ A710. The uncommitted collector of the output stage makes the LM319 compatible with RTL, DTL, and TTL as well as capable of driving lamps and relays at currents up to 25mA.

Although designed primarily for applications requiring operation from digital logic supplies, the LM319 series are fully specified for power supplies up to $\pm 15V$. It features faster response than the LM111 at the expense of higher power dissipation. However, the high-speed, wide operating voltage range and low package count make the LM319 much more versatile than older devices like the μ A711.

PIN CONFIGURATION

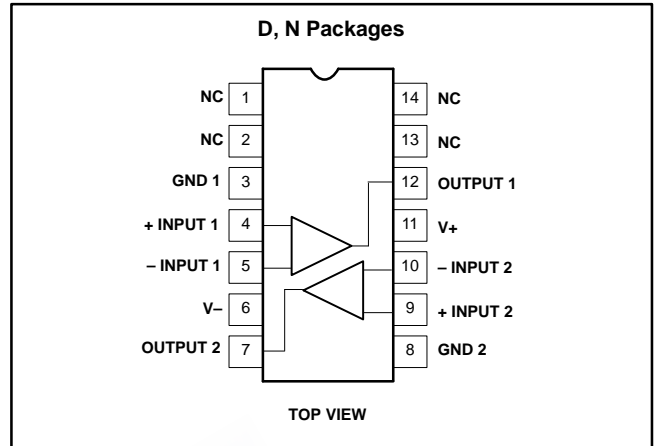

FEATURES

- Two independent comparators
- Operates from a single 5V supply
- Typically 80ns response time at $\pm 15V$
- Minimum fanout of 3 (each side)

- Maximum input current of $1\mu A$ over temperature
- Inputs and outputs can be isolated from system ground
- High common-mode slew rate

EQUIVALENT SCHEMATIC

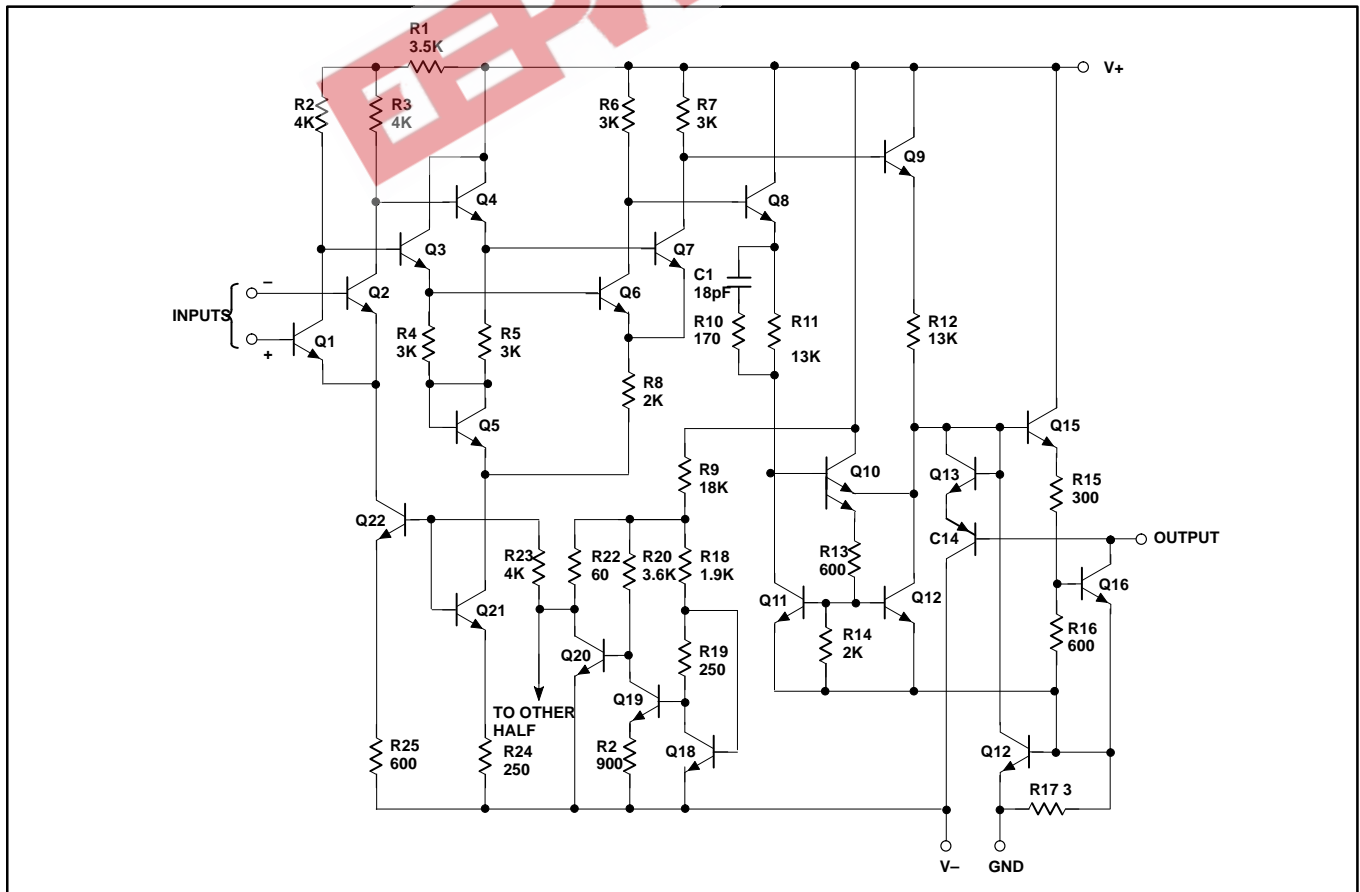

Dual voltage comparator

LM219/319

ORDERING INFORMATION

DESCRIPTION	TEMPERATURE RANGE	ORDER CODE	DWG #
14-Pin Plastic Small Outline (SO) Package	-25 to +85°C	LM219D	0175D
14-Pin Plastic Small Outline (SO) Package	0 to +70°C	LM319D	0175D
14-Pin Plastic Dual In-Line Package (DIP)	0 to +70°C	LM319N	0405B

ABSOLUTE MAXIMUM RATINGS

SYMBOL	PARAMETER	RATING	UNIT
V_S	Total supply voltage	36	V
	Output to negative supply voltage	36	V
	Ground to negative supply voltage	25	V
	Ground to positive supply voltage	18	V
	Differential input voltage	±5	V
V_{IN}	Input voltage ¹	±15	V
	Maximum power dissipation, $T_A=25^\circ\text{C}$ (still-air) ²		
	N package	1420	mW
	D package	1040	mW
	Output short-circuit duration	10	s
T_A	Operating temperature range	LM219	-25 to +85
		LM319	0 to +70
T_{STG}	Storage temperature range	-65 to +150	°C
T_{SOLD}	Lead soldering temperature (10sec max)	300	°C

NOTES:

- For supply voltages less than ±15V, the absolute maximum rating is equal to the supply voltage.
- Derate above 25°C, at the following rates:
N package at 11.4mW/°C
D package at 8.3mW/°C

DC ELECTRICAL CHARACTERISTICS

$V_S=\pm 15\text{V}$, $-25^\circ\text{C} \leq T_A \leq 85^\circ\text{C}$ for LM219, $0^\circ\text{C} \leq T_A \leq 70^\circ\text{C}$ for LM319, unless otherwise specified.

SYMBOL	PARAMETER	TEST CONDITIONS	LM219			LM319			UNIT
			Min	Typ	Max	Min	Typ	Max	
V_{OS}	Input offset voltage ^{1, 2}	$R_S \leq 5\text{k}\Omega$, $T_A=25^\circ\text{C}$ Over temp.		0.7	4.0		2.0	8.0	mV
I_{OS}	Input offset current ^{1, 2}	$T_A=25^\circ\text{C}$ Over temp.		30	75		80	200	nA
I_B	Input bias current ¹	$T_A=25^\circ\text{C}$ Over temp.		150	500		250	1000	nA
A_V	Voltage gain	$T_A=25^\circ\text{C}$	8	40		8	40		V/mV
V_{OL}	Saturation voltage	$V_{IN} \leq -10\text{mV}$, $I_{OUT}=25\text{mA}$, $T_A=25^\circ\text{C}$, $V_+ \geq 4.5\text{V}$, $V_- = 0$		0.75	1.5		0.75	1.5	V
		$V_{IN} \leq -10\text{mV}$, $I_{OUT}=3.2\text{mA}$		0.3	0.6		0.3	0.4	
I_{OH}	Output leakage current	$V_- = 0\text{V}$, $V_{IN} \geq 10\text{mV}$ $V_{OUT}=35\text{V}$, $T_A=25^\circ\text{C}$		0.2	10		0.2	10	μA
V_{IN}	Input voltage range	$V_S=\pm 15\text{V}$ $V_+ = 5\text{V}$, $V_- = 0\text{V}$	1	±13	3	1	±13	3	V
V_{ID}	Differential input voltage				±5			±5	V
I_+	Positive supply current	$V_+ = 5\text{V}$, $V_- = 0\text{V}$, $T_A=25^\circ\text{C}$		4.3			4.3		mA
I_+	Positive supply current	$V_S=\pm 15\text{V}$, $T_A=25^\circ\text{C}$		8.0	12.5		8.0	12.5	mA
I_-	Negative supply current	$V_S=\pm 15\text{V}$, $T_A=25^\circ\text{C}$		3.0	5.0		3.0	5.0	mA

NOTES:

- V_{OS} , I_{OS} and I_B specifications apply for a supply voltage range of $V_S=\pm 15\text{V}$ down to a single 5V supply.
- The offset voltages and offset currents given are the maximum values required to drive the output to within 1V of either supply with a 1mA load. Thus these parameters define an error band and take into account the worst case effects of voltage gain and input impedance.

Dual voltage comparator

LM219/319

AC ELECTRICAL CHARACTERISTICS

SYMBOL	PARAMETER	TEST CONDITIONS	LIMITS			UNIT
			Min	Typ	Max	
t_R	Response time ¹	$V_S = \pm 15V, T_A = 25^\circ C$ $R_L = 500\Omega$ (see test figure)		80		ns

NOTES:

1. The response time specified is for a 100mV step with 5mV overdrive.

TEST CIRCUIT

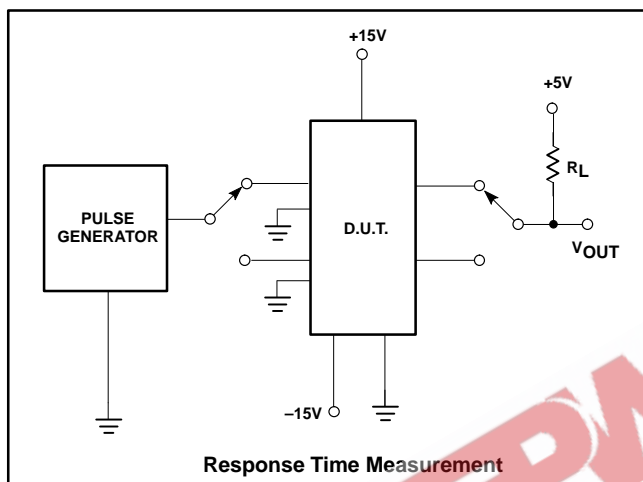

EPW.com.cn 电子产品世界

Dual voltage comparator

LM219/319

TYPICAL PERFORMANCE CHARACTERISTICS

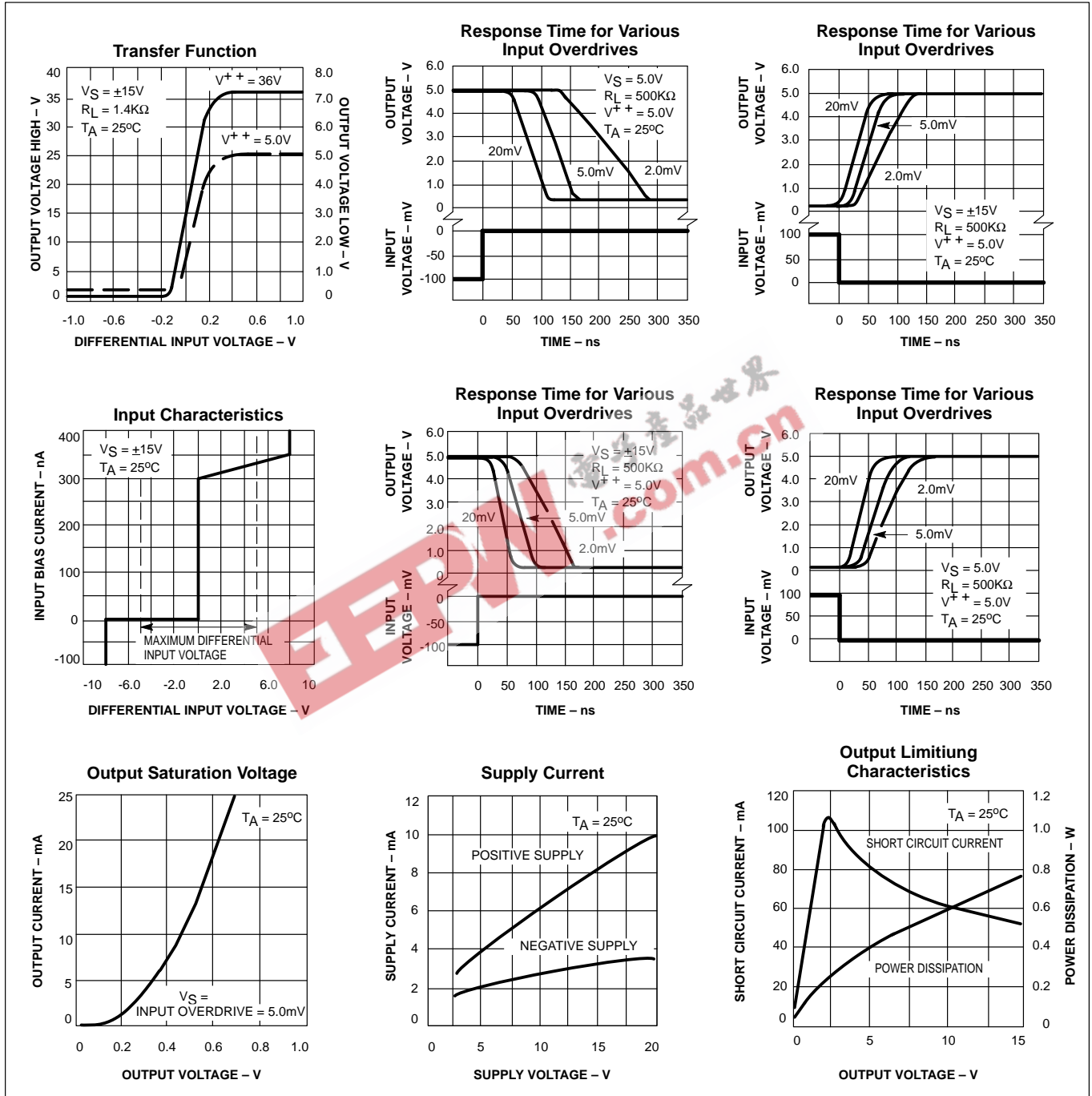

Dual voltage comparator

LM219/319

TYPICAL PERFORMANCE CHARACTERISTICS (Continued)

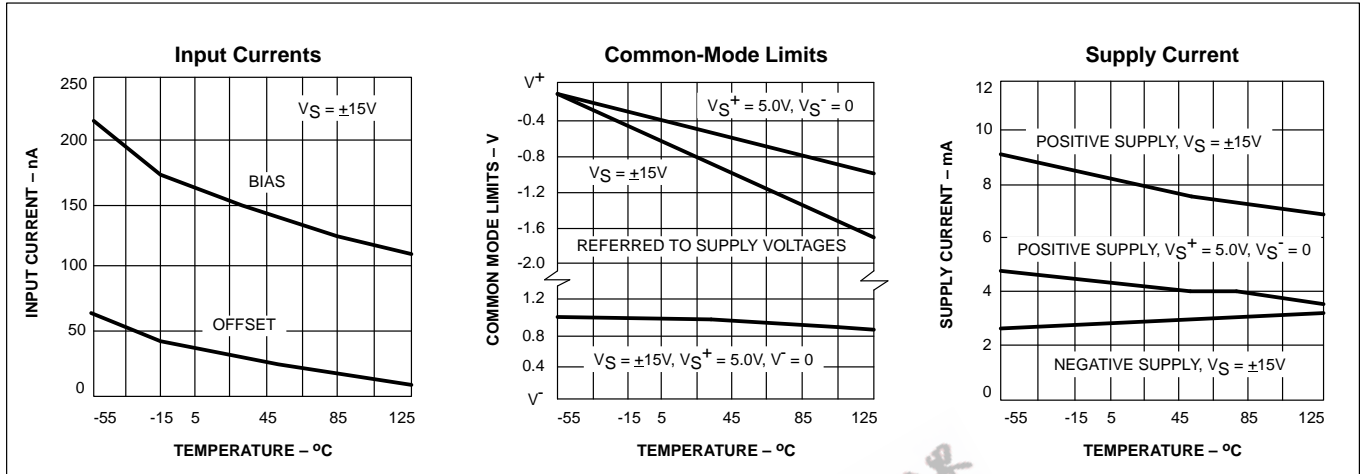

TYPICAL APPLICATIONS

