

# LM4040

## Precision Micropower Shunt Voltage Reference

### General Description

Ideal for space critical applications, the LM4040 precision voltage reference is available in the sub-miniature SC70 and SOT-23 surface-mount package. The LM4040's advanced design eliminates the need for an external stabilizing capacitor while ensuring stability with any capacitive load, thus making the LM4040 easy to use. Further reducing design effort is the availability of several fixed reverse breakdown voltages: 2.048V, 2.500V, 3.000V, 4.096V, 5.000V, 8.192V, and 10.000V. The minimum operating current increases from 60  $\mu$ A for the LM4040-2.5 to 100  $\mu$ A for the LM4040-10.0. All versions have a maximum operating current of 15 mA.

The LM4040 utilizes fuse and zener-zap reverse breakdown voltage trim during wafer sort to ensure that the prime parts have an accuracy of better than  $\pm 0.1\%$  (A grade) at 25°C. Bandgap reference temperature drift curvature correction and low dynamic impedance ensure stable reverse breakdown voltage accuracy over a wide range of operating temperatures and currents.

Also available is the LM4041 with two reverse breakdown voltage versions: adjustable and 1.2V. Please see the LM4041 data sheet.

### Features

- Small packages: SOT-23, TO-92 and SC70
- No output capacitor required
- Tolerates capacitive loads

- Fixed reverse breakdown voltages of 2.048V, 2.500V, 3.000V, 4.096V, 5.000V, 8.192V, and 10.000V

### Key Specifications (LM4040-2.5)

- Output voltage tolerance (A grade, 25°C)  $\pm 0.1\%$  (max)
- Low output noise (10 Hz to 10 kHz) 35  $\mu$ V<sub>rms</sub>(typ)
- Wide operating current range 60  $\mu$ A to 15 mA
- Industrial temperature range -40°C to +85°C
- Extended temperature range -40°C to +125°C
- Low temperature coefficient 100 ppm/°C (max)

### Applications

- Portable, Battery-Powered Equipment
- Data Acquisition Systems
- Instrumentation
- Process Control
- Energy Management
- Product Testing
- Automotive
- Precision Audio Components

### Connection Diagrams

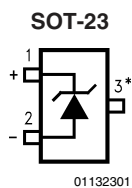

\*This pin must be left floating or connected to pin 2.

Top View

See NS Package Number MF03A  
(JEDEC Registration TO-236AB)

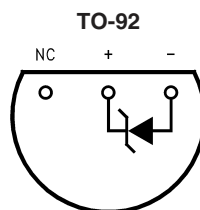

Bottom View

See NS Package Number Z03A

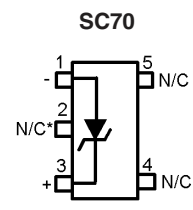

\*This pin must be left floating or connected to pin 1.

Top View

See NS Package Number MAA05A

## Ordering Information Industrial Temperature Range ( $-40^{\circ}\text{C}$ to $+85^{\circ}\text{C}$ )

Reverse Breakdown Voltage Tolerance at $25^{\circ}\text{C}$ and Average Reverse Breakdown Voltage Temperature Coefficient	Package					NS Package Number
	M3 (SOT-23)		M7 (SC70)		Z (TO-92)	
	Supplied as 1000 Units Tape and Reel	Supplied as 3000 Units tape and Reel	Supplied as 1000 Units Tape and Reel	Supplied as 3000 Units Tape and Reel		
$\pm 0.1\%$ , 100 ppm/ $^{\circ}\text{C}$ max (A grade)	LM4040AIM3-2.0 LM4040AIM3-2.5 LM4040AIM3-3.0 LM4040AIM3-4.1 LM4040AIM3-5.0 LM4040AIM3-8.2 LM4040AIM3-10.0	LM4040AIM3X-2.0 LM4040AIM3X-2.5 LM4040AIM3X-3.0 LM4040AIM3X-4.1 LM4040AIM3X-5.0 LM4040AIM3X-8.2 LM4040AIM3X-10.0			LM4040AIZ-2.0 LM4040AIZ-2.5 LM4040AIZ-3.0 LM4040AIZ-4.1 LM4040AIZ-5.0 LM4040AIZ-8.2 LM4040AIZ-10.0	MF03A, Z03A
$\pm 0.2\%$ , 100 ppm/ $^{\circ}\text{C}$ max (B grade)	LM4040BIM3-2.0 LM4040BIM3-2.5 LM4040BIM3-3.0 LM4040BIM3-4.1 LM4040BIM3-5.0 LM4040BIM3-8.2 LM4040BIM3-10.0	LM4040BIM3X-2.0 LM4040BIM3X-2.5 LM4040BIM3X-3.0 LM4040BIM3X-4.1 LM4040BIM3X-5.0 LM4040BIM3X-8.2 LM4040BIM3X-10.0	LM4040BIM7-2.0 LM4040BIM7-2.5 LM4040BIM7-3.0 LM4040BIM7-4.1 LM4040BIM7-5.0	LM4040BIM7X-2.0 LM4040BIM7X-2.5 LM4040BIM7X-3.0 LM4040BIM7X-4.1 LM4040BIM7X-5.0	LM4040BIZ-2.0 LM4040BIZ-2.5 LM4040BIZ-3.0 LM4040BIZ-4.1 LM4040BIZ-5.0 LM4040BIZ-8.2 LM4040BIZ-10.0	MF03A, Z03A, MAA05A
$\pm 0.5\%$ , 100 ppm/ $^{\circ}\text{C}$ max (C grade)	LM4040CIM3-2.0 LM4040CIM3-2.5 LM4040CIM3-3.0 LM4040CIM3-4.1 LM4040CIM3-5.0 LM4040CIM3-8.2 LM4040CIM3-10.0	LM4040CIM3X-2.0 LM4040CIM3X-2.5 LM4040CIM3X-3.0 LM4040CIM3X-4.1 LM4040CIM3X-5.0 LM4040CIM3X-8.2 LM4040CIM3X-10.0	LM4040CIM7-2.0 LM4040CIM7-2.5 LM4040CIM7-3.0 LM4040CIM7-4.1 LM4040CIM7-5.0	LM4040CIM7X-2.0 LM4040CIM7X-2.5 LM4040CIM7X-3.0 LM4040CIM7X-4.1 LM4040CIM7X-5.0	LM4040CIZ-2.0 LM4040CIZ-2.5 LM4040CIZ-3.0 LM4040CIZ-4.1 LM4040CIZ-5.0 LM4040CIZ-8.2 LM4040CIZ-10.0	MF03A, Z03A, MAA05A
$\pm 1.0\%$ , 150 ppm/ $^{\circ}\text{C}$ max (D grade)	LM4040DIM3-2.0 LM4040DIM3-2.5 LM4040DIM3-3.0 LM4040DIM3-4.1 LM4040DIM3-5.0 LM4040DIM3-8.2 LM4040DIM3-10.0	LM4040DIM3X-2.0 LM4040DIM3X-2.5 LM4040DIM3X-3.0 LM4040DIM3X-4.1 LM4040DIM3X-5.0 LM4040DIM3X-8.2 LM4040DIM3X-10.0	LM4040DIM7-2.0 LM4040DIM7-2.5 LM4040DIM7-3.0 LM4040DIM7-4.1 LM4040DIM7-5.0	LM4040DIM7X-2.0 LM4040DIM7X-2.5 LM4040DIM7X-3.0 LM4040DIM7X-4.1 LM4040DIM7X-5.0	LM4040DIZ-2.0 LM4040DIZ-2.5 LM4040DIZ-3.0 LM4040DIZ-4.1 LM4040DIZ-5.0 LM4040DIZ-8.2 LM4040DIZ-10.0	MF03A, Z03A, MAA05A
$\pm 2.0\%$ , 150 ppm/ $^{\circ}\text{C}$ max (E grade)	LM4040EIM3-2.0 LM4040EIM3-2.5 LM4040EIM3-3.0	LM4040EIM3X-2.0 LM4040EIM3X-2.5 LM4040EIM3X-3.0	LM4040EIM7-2.0 LM4040EIM7-2.5 LM4040EIM7-3.0	LM4040EIM7X-2.0 LM4040EIM7X-2.5 LM4040EIM7X-3.0	LM4040EIZ-2.0 LM4040EIZ-2.5 LM4040EIZ-3.0	MF03A, Z03A, MAA05A

**Extended Temperature Range (–40 °C to +125 °C)**

Reverse Breakdown Voltage Tolerance at 25 °C and Average Reverse Breakdown Voltage Temperature Coefficient	Package
	M3 (SOT-23) See NS Package Number MF03A
±0.5%, 100 ppm/°C max (C grade)	LM4040CEM3-2.0, LM4040CEM3-2.5, LM4040CEM3-3.0, LM4040CEM3-5.0
±1.0%, 150 ppm/°C max (D grade)	LM4040DEM3-2.0, LM4040DEM3-2.5, LM4040DEM3-3.0, LM4040DEM3-5.0
±2.0%, 150 ppm/°C max (E grade)	LM4040EEM3-2.0, LM4040EEM3-2.5, LM4040EEM3-3.0

EEPW 电子产品世界  
.com.cn

## SOT-23 AND SC70 Package Marking Information

Only three fields of marking are possible on the SOT-23's and SC70's small surface. This table gives the meaning of the three fields.

Part Marking	Field Definition
RJA SOT-23 only R2A SOT-23 only RKA SOT-23 only R4A SOT-23 only R5A SOT-23 only  R8A SOT-23 only R0A SOT-23 only	First Field:  R = Reference Second Field: J = 2.048V Voltage Option 2 = 2.500V Voltage Option K = 3.000V Voltage Option 4 = 4.096V Voltage Option
RJB R2B RKB R4B R5B R8B SOT-23 only R0B SOT-23 only	5 = 5.000V Voltage Option  8 = 8.192V Voltage Option 0 = 10.000V Voltage Option
RJC R2C RKC R4C R5C R8C SOT-23 only R0C SOT-23 only	Third Field:  A–E = Initial Reverse Breakdown Voltage or Reference Voltage Tolerance  A = $\pm 0.1\%$ , B = $\pm 0.2\%$ , C = $+0.5\%$ , D = $\pm 1.0\%$ , E = $\pm 2.0\%$
RJD R2D RKD R4D R5D R8D SOT-23 only R0D SOT-23 only	
RJE R2E RKE	

**Absolute Maximum Ratings** (Note 1)

If Military/Aerospace specified devices are required, please contact the National Semiconductor Sales Office/Distributors for availability and specifications.

Reverse Current	20 mA
Forward Current	10 mA
Power Dissipation ( $T_A = 25^\circ\text{C}$ ) (Note 2)	
M3 Package	306 mW
Z Package	550 mW
M7 Package	241 mW
Storage Temperature	$-65^\circ\text{C}$ to $+150^\circ\text{C}$
Lead Temperature	
M3 Package	
Vapor phase (60 seconds)	$+215^\circ\text{C}$
Infrared (15 seconds)	$+220^\circ\text{C}$
Z Package	
Soldering (10 seconds)	$+260^\circ\text{C}$
ESD Susceptibility	
Human Body Model (Note 3)	2 kV

Machine Model (Note 3)

200V

See AN-450 "Surface Mounting Methods and Their Effect on Product Reliability" for other methods of soldering surface mount devices.

**Operating Ratings**(Notes 1, 2)

Temperature Range	$(T_{\min} \leq T_A \leq T_{\max})$
Industrial Temperature Range	$-40^\circ\text{C} \leq T_A \leq +85^\circ\text{C}$
Extended Temperature Range	$-40^\circ\text{C} \leq T_A \leq +125^\circ\text{C}$
Reverse Current	
LM4040-2.0	60 $\mu\text{A}$ to 15 mA
LM4040-2.5	60 $\mu\text{A}$ to 15 mA
LM4040-3.0	62 $\mu\text{A}$ to 15 mA
LM4040-4.1	68 $\mu\text{A}$ to 15 mA
LM4040-5.0	74 $\mu\text{A}$ to 15 mA
LM4040-8.2	91 $\mu\text{A}$ to 15 mA
LM4040-10.0	100 $\mu\text{A}$ to 15 mA

**LM4040-2.0****Electrical Characteristics (Industrial Temperature Range)**

**Boldface limits apply for  $T_A = T_J = T_{\min}$  to  $T_{\max}$** ; all other limits  $T_A = T_J = 25^\circ\text{C}$ . The grades A and B designate initial Reverse Breakdown Voltage tolerances of  $\pm 0.1\%$  and  $\pm 0.2\%$ , respectively.

Symbol	Parameter	Conditions	Typical (Note 4)	LM4040AIM3 LM4040AIZ (Limit) (Note 5)	LM4040BIM3 LM4040BIZ LM4040BIM7 (Limit) (Note 5)	Units (Limit)
$V_R$	Reverse Breakdown Voltage	$I_R = 100 \mu\text{A}$	2.048			V
	Reverse Breakdown Voltage Tolerance (Note 6)	$I_R = 100 \mu\text{A}$		$\pm 2.0$ <b><math>\pm 15</math></b>	$\pm 4.1$ <b><math>\pm 17</math></b>	mV (max) mV (max)
$I_{R\text{MIN}}$	Minimum Operating Current		45	60 <b>65</b>	60 <b>65</b>	$\mu\text{A}$ $\mu\text{A}$ (max) $\mu\text{A}$ (max)
$\Delta V_R/\Delta T$	Average Reverse Breakdown Voltage Temperature Coefficient (Note 6)	$I_R = 10 \text{ mA}$	$\pm 20$			ppm/ $^\circ\text{C}$
		$I_R = 1 \text{ mA}$	$\pm 15$	<b><math>\pm 100</math></b>	<b><math>\pm 100</math></b>	ppm/ $^\circ\text{C}$ (max)
		$I_R = 100 \mu\text{A}$	$\pm 15$			ppm/ $^\circ\text{C}$
$\Delta V_R/\Delta I_R$	Reverse Breakdown Voltage Change with Operating Current Change (Note *NO TARGET FOR FNxref NS4914*)	$I_{R\text{MIN}} \leq I_R \leq 1 \text{ mA}$	0.3	0.8 <b>1.0</b>	0.8 <b>1.0</b>	mV mV (max) mV (max)
		$1 \text{ mA} \leq I_R \leq 15 \text{ mA}$	2.5	6.0 <b>8.0</b>	6.0 <b>8.0</b>	mV mV (max) mV (max)
$Z_R$	Reverse Dynamic Impedance	$I_R = 1 \text{ mA}$ , $f = 120 \text{ Hz}$ , $I_{AC} = 0.1 I_R$	0.3	0.8	0.8	$\Omega$ $\Omega$ (max)
$e_N$	Wideband Noise	$I_R = 100 \mu\text{A}$ $10 \text{ Hz} \leq f \leq 10 \text{ kHz}$	35			$\mu\text{V}_{\text{rms}}$

**LM4040-2.0****Electrical Characteristics (Industrial Temperature Range)** (Continued)

**Boldface limits apply for  $T_A = T_J = T_{MIN}$  to  $T_{MAX}$** ; all other limits  $T_A = T_J = 25^\circ\text{C}$ . The grades A and B designate initial Reverse Breakdown Voltage tolerances of  $\pm 0.1\%$  and  $\pm 0.2\%$ , respectively.

Symbol	Parameter	Conditions	Typical (Note 4)	LM4040AIM3 LM4040AIZ (Limit) (Note 5)	LM4040BIM3 LM4040BIZ LM4040BIM7 (Limit) (Note 5)	Units (Limit)
$\Delta V_R$	Reverse Breakdown Voltage Long Term Stability	t = 1000 hrs T = $25^\circ\text{C} \pm 0.1^\circ\text{C}$ $I_R = 100 \mu\text{A}$	120			ppm
$V_{HYST}$	Thermal Hysteresis (Note 8)	$\Delta T = -40^\circ\text{C}$ to $+125^\circ\text{C}$	0.08			%

**LM4040-2.0****Electrical Characteristics (Industrial Temperature Range)**

**Boldface limits apply for  $T_A = T_J = T_{MIN}$  to  $T_{MAX}$** ; all other limits  $T_A = T_J = 25^\circ\text{C}$ . The grades C, D and E designate initial Reverse Breakdown Voltage tolerances of  $\pm 0.5\%$ ,  $\pm 1.0\%$  and  $\pm 2.0\%$ , respectively.

Symbol	Parameter	Conditions	Typical (Note 4)	LM4040CIM3 LM4040CIZ LM4040CIM7 (Limit) (Note 5)	LM4040DIM3 LM4040DIZ LM4040DIM7 (Limit) (Note 5)	LM4040EIM7 LM4040EIZ (Limit) (Note 5)	Units (Limit)	
$V_R$	Reverse Breakdown Voltage	$I_R = 100 \mu\text{A}$	2.048				V	
	Reverse Breakdown Voltage Tolerance (Note 6)	$I_R = 100 \mu\text{A}$		$\pm 10$ <b><math>\pm 23</math></b>	$\pm 20$ <b><math>\pm 40</math></b>	$\pm 41$ <b><math>\pm 60</math></b>	mV (max) mV (max)	
$I_{RMIN}$	Minimum Operating Current		45	60 <b>65</b>	65 <b>70</b>	65 <b>70</b>	$\mu\text{A}$ $\mu\text{A}$ (max) $\mu\text{A}$ (max)	
		$\Delta V_R/\Delta T$	Average Reverse Breakdown Voltage Temperature Coefficient (Note 6)	$I_R = 10 \text{ mA}$ $I_R = 1 \text{ mA}$ $I_R = 100 \mu\text{A}$	$\pm 20$ $\pm 15$ $\pm 15$	<b><math>\pm 100</math></b> <b><math>\pm 150</math></b> <b><math>\pm 150</math></b>	<b><math>\pm 150</math></b>	ppm/ $^\circ\text{C}$ ppm/ $^\circ\text{C}$ (max) ppm/ $^\circ\text{C}$
		$\Delta V_R/\Delta I_R$	Reverse Breakdown Voltage Change with Operating Current Change (Note *NO TARGET FOR FNXref NS4914*)	$I_{RMIN} \leq I_R \leq 1 \text{ mA}$  $1 \text{ mA} \leq I_R \leq 15 \text{ mA}$	0.3  2.5	0.8 <b>1.0</b>  6.0 <b>8.0</b>	1.0 <b>1.2</b>  8.0 <b>10.0</b>	1.0 <b>1.2</b>  8.0 <b>10.0</b>
$Z_R$	Reverse Dynamic Impedance	$I_R = 1 \text{ mA}$ , f = 120 Hz $I_{AC} = 0.1 I_R$	0.3	0.9	1.1	1.1	$\Omega$ $\Omega$ (max)	
$e_N$	Wideband Noise	$I_R = 100 \mu\text{A}$ 10 Hz $\leq f \leq$ 10 kHz	35				$\mu\text{V}_{rms}$	
$\Delta V_R$	Reverse Breakdown Voltage Long Term Stability	t = 1000 hrs T = $25^\circ\text{C} \pm 0.1^\circ\text{C}$ $I_R = 100 \mu\text{A}$	120				ppm	
$V_{HYST}$	Thermal Hysteresis (Note 8)	$\Delta T = -40^\circ\text{C}$ to $+125^\circ\text{C}$	0.08				%	

## LM4040-2.0 Electrical Characteristics (Extended Temperature Range)

**Boldface limits apply for  $T_A = T_J = T_{MIN}$  to  $T_{MAX}$** ; all other limits  $T_A = T_J = 25^\circ\text{C}$ . The grades C, D and E designate initial Reverse Breakdown Voltage tolerances of  $\pm 0.5\%$ ,  $\pm 1.0\%$  and  $\pm 2.0\%$ , respectively.

Symbol	Parameter	Conditions	Typical (Note 4)	LM4040CEM3 (Limit) (Note 5)	LM4040DEM3 (Limit) (Note 5)	LM4040EEM3 (Limit) (Note 5)	Units (Limit)
$V_R$	Reverse Breakdown Voltage	$I_R = 100 \mu\text{A}$	2.048				V
	Reverse Breakdown Voltage Tolerance (Note 6)	$I_R = 100 \mu\text{A}$		$\pm 10$ <b><math>\pm 30</math></b>	$\pm 20$ <b><math>\pm 50</math></b>	$\pm 41$ <b><math>\pm 70</math></b>	mV (max) mV (max)
$I_{RMIN}$	Minimum Operating Current		45	60 <b>68</b>	65 <b>73</b>	65 <b>73</b>	$\mu\text{A}$ $\mu\text{A}$ (max) $\mu\text{A}$ (max)
$\Delta V_R/\Delta T$	Average Reverse Breakdown Voltage Temperature Coefficient (Note 6)	$I_R = 10 \text{ mA}$	$\pm 20$				ppm/ $^\circ\text{C}$
		$I_R = 1 \text{ mA}$	$\pm 15$	<b><math>\pm 100</math></b>	<b><math>\pm 150</math></b>	<b><math>\pm 150</math></b>	ppm/ $^\circ\text{C}$ (max)
		$I_R = 100 \mu\text{A}$	$\pm 15$				ppm/ $^\circ\text{C}$
$\Delta V_R/\Delta I_R$	Reverse Breakdown Voltage Change with Operating Current Change (Note 7)	$I_{RMIN} \leq I_R \leq 1 \text{ mA}$	0.3	0.8 <b>1.0</b>	1.0 <b>1.2</b>	1.0 <b>1.2</b>	mV mV (max) mV (max)
		$1 \text{ mA} \leq I_R \leq 15 \text{ mA}$	2.5	6.0 <b>8.0</b>	8.0 <b>10.0</b>	8.0 <b>10.0</b>	mV mV (max) mV (max)
$Z_R$	Reverse Dynamic Impedance	$I_R = 1 \text{ mA}$ , $f = 120 \text{ Hz}$ , $I_{AC} = 0.1 I_R$	0.3	0.9	1.1	1.1	$\Omega$ $\Omega$ (max)
$e_N$	Wideband Noise	$I_R = 100 \mu\text{A}$ $10 \text{ Hz} \leq f \leq 10 \text{ kHz}$	35				$\mu\text{V}_{\text{rms}}$
$\Delta V_R$	Reverse Breakdown Voltage Long Term Stability	$t = 1000 \text{ hrs}$ $T = 25^\circ\text{C} \pm 0.1^\circ\text{C}$ $I_R = 100 \mu\text{A}$	120				ppm
$V_{HYST}$	Thermal Hysteresis (Note 8)	$\Delta T = -40^\circ\text{C}$ to $+125^\circ\text{C}$	0.08				%

## LM4040-2.5 Electrical Characteristics (Industrial Temperature Range)

**Boldface limits apply for  $T_A = T_J = T_{MIN}$  to  $T_{MAX}$** ; all other limits  $T_A = T_J = 25^\circ\text{C}$ . The grades A and B designate initial Reverse Breakdown Voltage tolerances of  $\pm 0.1\%$  and  $\pm 0.2\%$ , respectively.

Symbol	Parameter	Conditions	Typical (Note 4)	LM4040AIM3 LM4040AIZ (Limit) (Note 5)	LM4040BIM3 LM4040BIZ LM4040BIM7 Limits (Note 5)	Units (Limit)
$V_R$	Reverse Breakdown Voltage	$I_R = 100 \mu\text{A}$	2.500			V
	Reverse Breakdown Voltage Tolerance (Note 6)	$I_R = 100 \mu\text{A}$		$\pm 2.5$ <b><math>\pm 19</math></b>	$\pm 5.0$ <b><math>\pm 21</math></b>	mV (max) mV (max)
$I_{RMIN}$	Minimum Operating Current		45	60 <b>65</b>	60 <b>65</b>	$\mu\text{A}$ $\mu\text{A}$ (max) $\mu\text{A}$ (max)

**LM4040-2.5****Electrical Characteristics (Industrial Temperature Range)** (Continued)

**Boldface limits apply for  $T_A = T_J = T_{MIN}$  to  $T_{MAX}$** ; all other limits  $T_A = T_J = 25^\circ\text{C}$ . The grades A and B designate initial Reverse Breakdown Voltage tolerances of  $\pm 0.1\%$  and  $\pm 0.2\%$ , respectively.

Symbol	Parameter	Conditions	Typical (Note 4)	LM4040AIM3 LM4040AIZ (Limit) (Note 5)	LM4040BIM3 LM4040BIZ LM4040BIM7 Limits (Note 5)	Units (Limit)
$\Delta V_R/\Delta T$	Average Reverse Breakdown Voltage Temperature Coefficient (Note 6)	$I_R = 10\text{ mA}$ $I_R = 1\text{ mA}$ $I_R = 100\text{ }\mu\text{A}$	$\pm 20$ $\pm 15$ $\pm 15$	<b><math>\pm 100</math></b>	<b><math>\pm 100</math></b>	ppm/ $^\circ\text{C}$ ppm/ $^\circ\text{C}$ (max) ppm/ $^\circ\text{C}$
$\Delta V_R/\Delta I_R$	Reverse Breakdown Voltage Change with Operating Current Change (Note 7)	$I_{RMIN} \leq I_R \leq 1\text{ mA}$	0.3	0.8 <b>1.0</b>	0.8 <b>1.0</b>	mV mV (max) mV (max)
		$1\text{ mA} \leq I_R \leq 15\text{ mA}$	2.5	6.0 <b>8.0</b>	6.0 <b>8.0</b>	mV mV (max) mV (max)
$Z_R$	Reverse Dynamic Impedance	$I_R = 1\text{ mA}$ , $f = 120\text{ Hz}$ , $I_{AC} = 0.1 I_R$	0.3	0.8	0.8	$\Omega$ $\Omega$ (max)
$e_N$	Wideband Noise	$I_R = 100\text{ }\mu\text{A}$ $10\text{ Hz} \leq f \leq 10\text{ kHz}$	35			$\mu\text{V}_{\text{rms}}$
$\Delta V_R$	Reverse Breakdown Voltage Long Term Stability	$t = 1000\text{ hrs}$ $T = 25^\circ\text{C} \pm 0.1^\circ\text{C}$ $I_R = 100\text{ }\mu\text{A}$	120			ppm
$V_{HYST}$	Thermal Hysteresis (Note 8)	$\Delta T = -40^\circ\text{C}$ to $+125^\circ\text{C}$	0.08			%

**LM4040-2.5****Electrical Characteristics (Industrial Temperature Range)**

**Boldface limits apply for  $T_A = T_J = T_{MIN}$  to  $T_{MAX}$** ; all other limits  $T_A = T_J = 25^\circ\text{C}$ . The grades C, D and E designate initial Reverse Breakdown Voltage tolerances of  $\pm 0.5\%$ ,  $\pm 1.0\%$  and  $\pm 2.0\%$ , respectively.

Symbol	Parameter	Conditions	Typical (Note 4)	LM4040CIM3 LM4040DIZ LM4040CIM7 Limits (Note 5)	LM4040DIM3 LM4040DIZ LM4040DIM7 Limits (Note 5)	LM4040EIM7 LM4040EIZ Limits (Note 5)	Units (Limit)
$V_R$	Reverse Breakdown Voltage	$I_R = 100\text{ }\mu\text{A}$	2.500				V
	Reverse Breakdown Voltage Tolerance (Note 6)	$I_R = 100\text{ }\mu\text{A}$		$\pm 12$ <b><math>\pm 29</math></b>	$\pm 25$ <b><math>\pm 49</math></b>	$\pm 50$ <b><math>\pm 74</math></b>	mV (max) mV (max)
$I_{RMIN}$	Minimum Operating Current		45	60 <b>65</b>	65 <b>70</b>	65 <b>70</b>	$\mu\text{A}$ $\mu\text{A}$ (max) $\mu\text{A}$ (max)
		$I_R = 10\text{ mA}$	$\pm 20$				ppm/ $^\circ\text{C}$
		$I_R = 1\text{ mA}$ $I_R = 100\text{ }\mu\text{A}$	$\pm 15$ $\pm 15$	<b><math>\pm 100</math></b>	<b><math>\pm 150</math></b>	<b><math>\pm 150</math></b>	ppm/ $^\circ\text{C}$ (max) ppm/ $^\circ\text{C}$



**LM4040-2.5****Electrical Characteristics (Industrial Temperature Range)** (Continued)

**Boldface limits apply for  $T_A = T_J = T_{MIN}$  to  $T_{MAX}$** ; all other limits  $T_A = T_J = 25^\circ\text{C}$ . The grades C, D and E designate initial Reverse Breakdown Voltage tolerances of  $\pm 0.5\%$ ,  $\pm 1.0\%$  and  $\pm 2.0\%$ , respectively.

Symbol	Parameter	Conditions	Typical (Note 4)	LM4040CIM3 LM4040DIZ LM4040CIM7 Limits (Note 5)	LM4040DIM3 LM4040DIZ LM4040DIM7 Limits (Note 5)	LM4040EIM7 LM4040EIZ Limits (Note 5)	Units (Limit)
$\Delta V_R/\Delta I_R$	Reverse Breakdown Voltage Change with Operating Current Change (Note 7)	$I_{RMIN} \leq I_R \leq 1 \text{ mA}$	0.3	0.8 <b>1.0</b>	1.0 <b>1.2</b>	1.0 <b>1.2</b>	mV mV (max) mV (max)
		$1 \text{ mA} \leq I_R \leq 15 \text{ mA}$	2.5	6.0 <b>8.0</b>	8.0 <b>10.0</b>	8.0 <b>10.0</b>	mV mV (max) mV (max)
$Z_R$	Reverse Dynamic Impedance	$I_R = 1 \text{ mA}$ , $f = 120 \text{ Hz}$ $I_{AC} = 0.1 I_R$	0.3	0.9	1.1	1.1	$\Omega$ $\Omega(\text{max})$
$e_N$	Wideband Noise	$I_R = 100 \mu\text{A}$ $10 \text{ Hz} \leq f \leq 10 \text{ kHz}$	35				$\mu\text{V}_{\text{rms}}$
$\Delta V_R$	Reverse Breakdown Voltage Long Term Stability	$t = 1000 \text{ hrs}$ $T = 25^\circ\text{C} \pm 0.1^\circ\text{C}$ $I_R = 100 \mu\text{A}$	120				ppm
$V_{\text{HYST}}$	Thermal Hysteresis (Note 8)	$\Delta T = -40^\circ\text{C}$ to $+125^\circ\text{C}$	0.08				%

**LM4040-2.5****Electrical Characteristics (Extended Temperature Range)**

**Boldface limits apply for  $T_A = T_J = T_{MIN}$  to  $T_{MAX}$** ; all other limits  $T_A = T_J = 25^\circ\text{C}$ . The grades C, D and E designate initial Reverse Breakdown Voltage tolerances of  $\pm 0.5\%$ ,  $\pm 1.0\%$  and  $\pm 2.0\%$ , respectively.

Symbol	Parameter	Conditions	Typical (Note 4)	LM4040CEM3 Limits (Note 5)	LM4040DEM3 Limits (Note 5)	LM4040EEM3 Limits (Note 5)	Units (Limit)
$V_R$	Reverse Breakdown Voltage	$I_R = 100 \mu\text{A}$	2.500				V
	Reverse Breakdown Voltage Tolerance (Note 6)	$I_R = 100 \mu\text{A}$		$\pm 12$ <b><math>\pm 38</math></b>	$\pm 25$ <b><math>\pm 63</math></b>	$\pm 50$ <b><math>\pm 88</math></b>	mV (max) mV (max)
$I_{RMIN}$	Minimum Operating Current		45	60 <b>68</b>	65 <b>73</b>	65 <b>73</b>	$\mu\text{A}$ $\mu\text{A}$ (max) $\mu\text{A}$ (max)
$\Delta V_R/\Delta T$	Average Reverse Breakdown Voltage Temperature Coefficient (Note 6)	$I_R = 10 \text{ mA}$	$\pm 20$				ppm/ $^\circ\text{C}$
		$I_R = 1 \text{ mA}$	$\pm 15$	<b><math>\pm 100</math></b>	<b><math>\pm 150</math></b>	<b><math>\pm 150</math></b>	ppm/ $^\circ\text{C}$ (max)
		$I_R = 100 \mu\text{A}$	$\pm 15$				ppm/ $^\circ\text{C}$
$\Delta V_R/\Delta I_R$	Reverse Breakdown Voltage Change with Operating Current Change (Note 7)	$I_{RMIN} \leq I_R \leq 1 \text{ mA}$	0.3	0.8 <b>1.0</b>	1.0 <b>1.2</b>	1.0 <b>1.2</b>	mV mV (max) mV (max)
		$1 \text{ mA} \leq I_R \leq 15 \text{ mA}$	2.5	6.0 <b>8.0</b>	8.0 <b>10.0</b>	8.0 <b>10.0</b>	mV mV (max) mV (max)

**LM4040-2.5****Electrical Characteristics (Extended Temperature Range)** (Continued)

**Boldface limits apply for  $T_A = T_J = T_{MIN}$  to  $T_{MAX}$** ; all other limits  $T_A = T_J = 25^\circ\text{C}$ . The grades C, D and E designate initial Reverse Breakdown Voltage tolerances of  $\pm 0.5\%$ ,  $\pm 1.0\%$  and  $\pm 2.0\%$ , respectively.

Symbol	Parameter	Conditions	Typical (Note 4)	LM4040CEM3 Limits (Note 5)	LM4040DEM3 Limits (Note 5)	LM4040EEM3 Limits (Note 5)	Units (Limit)
$Z_R$	Reverse Dynamic Impedance	$I_R = 1 \text{ mA}$ , $f = 120 \text{ Hz}$ , $I_{AC} = 0.1 I_R$	0.3	0.9	1.1	1.1	$\Omega$ $\Omega$ (max)
$e_N$	Wideband Noise	$I_R = 100 \mu\text{A}$ $10 \text{ Hz} \leq f \leq 10 \text{ kHz}$	35				$\mu\text{V}_{\text{rms}}$
$\Delta V_R$	Reverse Breakdown Voltage Long Term Stability	$t = 1000 \text{ hrs}$ $T = 25^\circ\text{C} \pm 0.1^\circ\text{C}$ $I_R = 100 \mu\text{A}$	120				ppm
$V_{\text{HYST}}$	Thermal Hysteresis (Note 8)	$\Delta T = -40^\circ\text{C}$ to $+125^\circ\text{C}$	0.08				%

**LM4040-3.0****Electrical Characteristics (Industrial Temperature Range)**

**Boldface limits apply for  $T_A = T_J = T_{MIN}$  to  $T_{MAX}$** ; all other limits  $T_A = T_J = 25^\circ\text{C}$ . The grades A and B designate initial Reverse Breakdown Voltage tolerances of  $\pm 0.1\%$  and  $\pm 0.2\%$ , respectively.

Symbol	Parameter	Conditions	Typical (Note 4)	LM4040AIM3 LM4040AIZ (Limit) (Note 5)	LM4040BIM3 LM4040BIZ LM4040BIM7 Limits (Note 5)	Units (Limit)
$V_R$	Reverse Breakdown Voltage	$I_R = 100 \mu\text{A}$	3.000			V
	Reverse Breakdown Voltage Tolerance (Note 6)	$I_R = 100 \mu\text{A}$		$\pm 3.0$ <b><math>\pm 22</math></b>	$\pm 6.0$ <b><math>\pm 26</math></b>	mV (max) mV (max)
$I_{R\text{MIN}}$	Minimum Operating Current		47	62 <b>67</b>	62 <b>67</b>	$\mu\text{A}$ $\mu\text{A}$ (max) $\mu\text{A}$ (max)
		$I_R = 10 \text{ mA}$	$\pm 20$	<b><math>\pm 100</math></b>	<b><math>\pm 100</math></b>	ppm/ $^\circ\text{C}$
		$I_R = 1 \text{ mA}$	$\pm 15$			ppm/ $^\circ\text{C}$ (max)
$I_R = 100 \mu\text{A}$	$\pm 15$		ppm/ $^\circ\text{C}$			
$\Delta V_R / \Delta I_R$	Reverse Breakdown Voltage Change with Operating Current Change (Note 7)	$I_{R\text{MIN}} \leq I_R \leq 1 \text{ mA}$	0.6	0.8 <b>1.1</b>	0.8 <b>1.1</b>	mV mV (max) mV (max)
		$1 \text{ mA} \leq I_R \leq 15 \text{ mA}$	2.7	6.0 <b>9.0</b>	6.0 <b>9.0</b>	mV mV (max) mV (max)
$Z_R$	Reverse Dynamic Impedance	$I_R = 1 \text{ mA}$ , $f = 120 \text{ Hz}$ , $I_{AC} = 0.1 I_R$	0.4	0.9	0.9	$\Omega$ $\Omega$ (max)
$e_N$	Wideband Noise	$I_R = 100 \mu\text{A}$ $10 \text{ Hz} \leq f \leq 10 \text{ kHz}$	35			$\mu\text{V}_{\text{rms}}$
$\Delta V_R$	Reverse Breakdown Voltage Long Term Stability	$t = 1000 \text{ hrs}$ $T = 25^\circ\text{C} \pm 0.1^\circ\text{C}$ $I_R = 100 \mu\text{A}$	120			ppm
$V_{\text{HYST}}$	Thermal Hysteresis (Note 8)	$\Delta T = -40^\circ\text{C}$ to $+125^\circ\text{C}$	0.08			%

### LM4040-3.0 Electrical Characteristics (Industrial Temperature Range)

**Boldface limits apply for  $T_A = T_J = T_{MIN}$  to  $T_{MAX}$** ; all other limits  $T_A = T_J = 25^\circ\text{C}$ . The grades C, D and E designate initial Reverse Breakdown Voltage tolerances of  $\pm 0.5\%$ ,  $\pm 1.0\%$  and  $\pm 2.0\%$ , respectively.

Symbol	Parameter	Conditions	Typical (Note 4)	LM4040CIM3 LM4040DIZ LM4040CIM7 Limits (Note 5)	LM4040DIM3 LM4040DIZ LM4040DIM7 Limits (Note 5)	LM4040EIM7 LM4040EIZ Limits (Note 5)	Units (Limit)	
$V_R$	Reverse Breakdown Voltage	$I_R = 100 \mu\text{A}$	3.000				V	
	Reverse Breakdown Voltage Tolerance (Note 6)	$I_R = 100 \mu\text{A}$		$\pm 15$ <b><math>\pm 34</math></b>	$\pm 30$ <b><math>\pm 59</math></b>	$\pm 60$ <b><math>\pm 89</math></b>	mV (max) mV (max)	
$I_{RMIN}$	Minimum Operating Current		45	60 <b>65</b>	65 <b>70</b>	65 <b>70</b>	$\mu\text{A}$ $\mu\text{A}$ (max) $\mu\text{A}$ (max)	
		Average Reverse Breakdown Voltage Temperature Coefficient (Note 6)	$I_R = 10 \text{ mA}$ $I_R = 1 \text{ mA}$ $I_R = 100 \mu\text{A}$	$\pm 20$ $\pm 15$ $\pm 15$	<b><math>\pm 100</math></b>	<b><math>\pm 150</math></b>	<b><math>\pm 150</math></b>	ppm/ $^\circ\text{C}$ ppm/ $^\circ\text{C}$ (max) ppm/ $^\circ\text{C}$
		Reverse Breakdown Voltage Change with Operating Current Change (Note 7)	$I_{RMIN} \leq I_R \leq 1 \text{ mA}$  $1 \text{ mA} \leq I_R \leq 15 \text{ mA}$	0.4  2.7	0.8 1.1 6.0 9.0	1.1 1.3 8.0 11.0	1.1 1.3 8.0 11.0	mV mV (max) mV (max) mV (max) mV (max)
$Z_R$	Reverse Dynamic Impedance	$I_R = 1 \text{ mA}$ , $f = 120 \text{ Hz}$ $I_{AC} = 0.1 I_R$	0.4	0.9	1.2	1.2	$\Omega$ $\Omega$ (max)	
$e_N$	Wideband Noise	$I_R = 100 \mu\text{A}$ $10 \text{ Hz} \leq f \leq 10 \text{ kHz}$	35				$\mu\text{V}_{rms}$	
$\Delta V_R$	Reverse Breakdown Voltage Long Term Stability	$t = 1000 \text{ hrs}$ $T = 25^\circ\text{C} \pm 0.1^\circ\text{C}$ $I_R = 100 \mu\text{A}$	120				ppm	
$V_{HYST}$	Thermal Hysteresis (Note 8)	$\Delta T = -40^\circ\text{C}$ to $+125^\circ\text{C}$	0.08				%	

### LM4040-3.0 Electrical Characteristics (Extended Temperature Range)

**Boldface limits apply for  $T_A = T_J = T_{MIN}$  to  $T_{MAX}$** ; all other limits  $T_A = T_J = 25^\circ\text{C}$ . The grades C, D and E designate initial Reverse Breakdown Voltage tolerances of  $\pm 0.5\%$ ,  $\pm 1.0\%$  and  $\pm 2.0\%$ , respectively.

Symbol	Parameter	Conditions	Typical (Note 4)	LM4040CEM3 Limits (Note 5)	LM4040DEM3 Limits (Note 5)	LM4040EEM3 Limits (Note 5)	Units (Limit)
$V_R$	Reverse Breakdown Voltage	$I_R = 100 \mu\text{A}$	3.000				V
	Reverse Breakdown Voltage Tolerance (Note 6)	$I_R = 100 \mu\text{A}$		$\pm 15$ <b><math>\pm 45</math></b>	$\pm 30$ <b><math>\pm 75</math></b>	$\pm 60$ <b><math>\pm 105</math></b>	mV (max) mV (max)
$I_{RMIN}$	Minimum Operating Current		47	62 <b>70</b>	67 <b>75</b>	67 <b>75</b>	$\mu\text{A}$ $\mu\text{A}$ (max) $\mu\text{A}$ (max)

**LM4040-3.0****Electrical Characteristics (Extended Temperature Range)** (Continued)

**Boldface limits apply for  $T_A = T_J = T_{MIN}$  to  $T_{MAX}$** ; all other limits  $T_A = T_J = 25^\circ\text{C}$ . The grades C, D and E designate initial Reverse Breakdown Voltage tolerances of  $\pm 0.5\%$ ,  $\pm 1.0\%$  and  $\pm 2.0\%$ , respectively.

Symbol	Parameter	Conditions	Typical (Note 4)	LM4040CEM3 Limits (Note 5)	LM4040DEM3 Limits (Note 5)	LM4040EEM3 Limits (Note 5)	Units (Limit)
$\Delta V_R/\Delta T$	Average Reverse Breakdown Voltage Temperature Coefficient (Note 6)	$I_R = 10\text{ mA}$	$\pm 20$				ppm/ $^\circ\text{C}$
		$I_R = 1\text{ mA}$	$\pm 15$	<b><math>\pm 100</math></b>	<b><math>\pm 150</math></b>	<b><math>\pm 150</math></b>	ppm/ $^\circ\text{C}$ (max)
		$I_R = 100\text{ }\mu\text{A}$	$\pm 15$				ppm/ $^\circ\text{C}$
$\Delta V_R/\Delta I_R$	Reverse Breakdown Voltage Change with Operating Current Change (Note 7)	$I_{RMIN} \leq I_R \leq 1\text{ mA}$	0.4	0.8	1.1	1.1	mV
				<b>1.1</b>	<b>1.3</b>	<b>1.3</b>	mV (max)
		$1\text{ mA} \leq I_R \leq 15\text{ mA}$	2.7	6.0	8.0	8.0	mV
				<b>9.0</b>	<b>11.0</b>	<b>11.0</b>	mV (max)
$Z_R$	Reverse Dynamic Impedance	$I_R = 1\text{ mA}$ , $f = 120\text{ Hz}$ , $I_{AC} = 0.1 I_R$	0.4	0.9	1.2	1.2	$\Omega$ $\Omega$ (max)
$e_N$	Wideband Noise	$I_R = 100\text{ }\mu\text{A}$ $10\text{ Hz} \leq f \leq 10\text{ kHz}$	35				$\mu\text{V}_{rms}$
$\Delta V_R$	Reverse Breakdown Voltage Long Term Stability	$t = 1000\text{ hrs}$ $T = 25^\circ\text{C} \pm 0.1^\circ\text{C}$ $I_R = 100\text{ }\mu\text{A}$	120				ppm
$V_{HYST}$	Thermal Hysteresis (Note 8)	$\Delta T = -40^\circ\text{C}$ to $+125^\circ\text{C}$	0.08				%

**LM4040-4.1****Electrical Characteristics (Industrial Temperature Range)**

**Boldface limits apply for  $T_A = T_J = T_{MIN}$  to  $T_{MAX}$** ; all other limits  $T_A = T_J = 25^\circ\text{C}$ . The grades A and B designate initial Reverse Breakdown Voltage tolerances of  $\pm 0.1\%$  and  $\pm 0.2\%$ , respectively.

Symbol	Parameter	Conditions	Typical (Note 4)	LM4040AIM3 LM4040AIZ Limits (Note 5)	LM4040BIM3 LM4040BIZ LM4040BIM7 Limits (Note 5)	Units (Limit)
$V_R$	Reverse Breakdown Voltage	$I_R = 100\text{ }\mu\text{A}$	4.096			V
	Reverse Breakdown Voltage Tolerance (Note 6)	$I_R = 100\text{ }\mu\text{A}$		$\pm 4.1$ <b><math>\pm 31</math></b>	$\pm 8.2$ <b><math>\pm 35</math></b>	mV (max) mV (max)
$I_{RMIN}$	Minimum Operating Current		50	68 <b>73</b>	68 <b>73</b>	$\mu\text{A}$ $\mu\text{A}$ (max) $\mu\text{A}$ (max)
$\Delta V_R/\Delta T$	Average Reverse Breakdown Voltage Temperature Coefficient (Note 6)	$I_R = 10\text{ mA}$	$\pm 30$			ppm/ $^\circ\text{C}$
		$I_R = 1\text{ mA}$	$\pm 20$	<b><math>\pm 100</math></b>	<b><math>\pm 100</math></b>	ppm/ $^\circ\text{C}$ (max)
		$I_R = 100\text{ }\mu\text{A}$	$\pm 20$			ppm/ $^\circ\text{C}$
$\Delta V_R/\Delta I_R$	Reverse Breakdown Voltage Change with Operating Current Change (Note 7)	$I_{RMIN} \leq I_R \leq 1\text{ mA}$	0.5	0.9	0.9	mV
				<b>1.2</b>	<b>1.2</b>	mV (max)
		$1\text{ mA} \leq I_R \leq 15\text{ mA}$	3.0	7.0	7.0	mV
				<b>10.0</b>	<b>10.0</b>	mV (max) mV (max)

**LM4040-4.1****Electrical Characteristics (Industrial Temperature Range)** (Continued)

**Boldface limits apply for  $T_A = T_J = T_{MIN}$  to  $T_{MAX}$ ; all other limits  $T_A = T_J = 25^\circ\text{C}$ .** The grades A and B designate initial Reverse Breakdown Voltage tolerances of  $\pm 0.1\%$  and  $\pm 0.2\%$ , respectively.

Symbol	Parameter	Conditions	Typical (Note 4)	<b>LM4040AIM3 LM4040AIZ Limits (Note 5)</b>	<b>LM4040BIM3 LM4040BIZ LM4040BIM7 Limits (Note 5)</b>	Units (Limit)
$Z_R$	Reverse Dynamic Impedance	$I_R = 1 \text{ mA}$ , $f = 120 \text{ Hz}$ , $I_{AC} = 0.1 I_R$	0.5	1.0	1.0	$\Omega$ $\Omega$ (max)
$e_N$	Wideband Noise	$I_R = 100 \mu\text{A}$ $10 \text{ Hz} \leq f \leq 10 \text{ kHz}$	80			$\mu\text{V}_{\text{rms}}$
$\Delta V_R$	Reverse Breakdown Voltage Long Term Stability	$t = 1000 \text{ hrs}$ $T = 25^\circ\text{C} \pm 0.1^\circ\text{C}$ $I_R = 100 \mu\text{A}$	120			ppm
$V_{\text{HYST}}$	Thermal Hysteresis (Note 8)	$\Delta T = -40^\circ\text{C}$ to $+125^\circ\text{C}$	0.08			%

EEPW 电子产品世界  
.com.cn

## LM4040-4.1 Electrical Characteristics (Industrial Temperature Range)

**Boldface limits apply for  $T_A = T_J = T_{MIN}$  to  $T_{MAX}$** ; all other limits  $T_A = T_J = 25^\circ\text{C}$ . The grades C and D designate initial Reverse Breakdown Voltage tolerances of  $\pm 0.5\%$  and  $\pm 1.0\%$ , respectively.

Symbol	Parameter	Conditions	Typical (Note 4)	LM4040CIM3 LM4040CIZ LM4040CIM7 Limits (Note 5)	LM4040DIM3 LM4040BIZ LM4040DIM7 Limits (Note 5)	Units (Limit)
$V_R$	Reverse Breakdown Voltage	$I_R = 100 \mu\text{A}$	4.096			V
	Reverse Breakdown Voltage Tolerance (Note 6)	$I_R = 100 \mu\text{A}$		$\pm 20$ <b><math>\pm 47</math></b>	$\pm 41$ <b><math>\pm 81</math></b>	mV (max) mV (max)
$I_{RMIN}$	Minimum Operating Current		50	68 <b>73</b>	73 <b>78</b>	$\mu\text{A}$ $\mu\text{A}$ (max) $\mu\text{A}$ (max)
$\Delta V_R/\Delta T$	Average Reverse Breakdown Voltage Temperature Coefficient (Note 6)	$I_R = 10 \text{ mA}$ $I_R = 1 \text{ mA}$ $I_R = 100 \mu\text{A}$	$\pm 30$ $\pm 20$ $\pm 20$	<b><math>\pm 100</math></b>	<b><math>\pm 150</math></b>	ppm/ $^\circ\text{C}$ ppm/ $^\circ\text{C}$ (max) ppm/ $^\circ\text{C}$
$\Delta V_R/\Delta I_R$	Reverse Breakdown Voltage Change with Operating Current Change (Note 7)	$I_{RMIN} \leq I_R \leq 1 \text{ mA}$	0.5	0.9 1.2	1.2 <b>1.5</b>	mV mV (max) mV (max)
		$1 \text{ mA} \leq I_R \leq 15 \text{ mA}$	3.0	7.0 <b>10.0</b>	9.0 <b>13.0</b>	mV mV (max) mV (max)
$Z_R$	Reverse Dynamic Impedance	$I_R = 1 \text{ mA}$ , $f = 120 \text{ Hz}$ , $I_{AC} = 0.1 I_R$	0.5	1.0	1.3	$\Omega$ $\Omega$ (max)
$e_N$	Wideband Noise	$I_R = 100 \mu\text{A}$ $10 \text{ Hz} \leq f \leq 10 \text{ kHz}$	80			$\mu\text{V}_{rms}$
$\Delta V_R$	Reverse Breakdown Voltage Long Term Stability	$t = 1000 \text{ hrs}$ $T = 25^\circ\text{C} \pm 0.1^\circ\text{C}$ $I_R = 100 \mu\text{A}$	120			ppm
$V_{HYST}$	Thermal Hysteresis (Note 8)	$\Delta T = -40^\circ\text{C}$ to $+125^\circ\text{C}$	0.08			%

## LM4040-5.0 Electrical Characteristics (Industrial Temperature Range)

**Boldface limits apply for  $T_A = T_J = T_{MIN}$  to  $T_{MAX}$** ; all other limits  $T_A = T_J = 25^\circ\text{C}$ . The grades A and B designate initial Reverse Breakdown Voltage tolerances of  $\pm 0.1\%$  and  $\pm 0.2\%$ , respectively.

Symbol	Parameter	Conditions	Typical (Note 4)	LM4040AIM3 LM4040AIZ Limits (Note 5)	LM4040BIM3 LM4040BIZ LM4040BIM7 Limits (Note 5)	Units (Limit)
$V_R$	Reverse Breakdown Voltage	$I_R = 100 \mu\text{A}$	5.000			V
	Reverse Breakdown Voltage Tolerance (Note 6)	$I_R = 100 \mu\text{A}$		$\pm 5.0$ <b><math>\pm 38</math></b>	$\pm 10$ <b><math>\pm 43</math></b>	mV (max) mV (max)
$I_{RMIN}$	Minimum Operating Current		54	74 <b>80</b>	74 <b>80</b>	$\mu\text{A}$ $\mu\text{A}$ (max) $\mu\text{A}$ (max)
		$I_R = 10 \text{ mA}$	$\pm 30$			ppm/ $^\circ\text{C}$
		$I_R = 1 \text{ mA}$ $I_R = 100 \mu\text{A}$	$\pm 20$ $\pm 20$	<b><math>\pm 100</math></b>	<b><math>\pm 100</math></b>	ppm/ $^\circ\text{C}$ (max) ppm/ $^\circ\text{C}$
$\Delta V_R / \Delta I_R$	Reverse Breakdown Voltage Change with Operating Current Change (Note 7)	$I_{RMIN} \leq I_R \leq 1 \text{ mA}$	0.5	1.0 1.4	1.0 1.4	mV mV (max) mV (max)
		$1 \text{ mA} \leq I_R \leq 15 \text{ mA}$	3.5	8.0 12.0	8.0 12.0	mV mV (max) mV (max)
$Z_R$	Reverse Dynamic Impedance	$I_R = 1 \text{ mA}$ , $f = 120 \text{ Hz}$ , $I_{AC} = 0.1 I_R$	0.5	1.1	1.1	$\Omega$ $\Omega$ (max)
$e_N$	Wideband Noise	$I_R = 100 \mu\text{A}$ $10 \text{ Hz} \leq f \leq 10 \text{ kHz}$	80			$\mu\text{V}_{rms}$
$\Delta V_R$	Reverse Breakdown Voltage Long Term Stability	$t = 1000 \text{ hrs}$ $T = 25^\circ\text{C} \pm 0.1^\circ\text{C}$ $I_R = 100 \mu\text{A}$	120			ppm
$V_{HYST}$	Thermal Hysteresis (Note 8)	$\Delta T = -40^\circ\text{C}$ to $+125^\circ\text{C}$	0.08			%

## LM4040-5.0 Electrical Characteristics (Industrial Temperature Range)

**Boldface limits apply for  $T_A = T_J = T_{MIN}$  to  $T_{MAX}$** ; all other limits  $T_A = T_J = 25^\circ\text{C}$ . The grades C and D designate initial Reverse Breakdown Voltage tolerances of  $\pm 0.5\%$  and  $\pm 1.0\%$ , respectively.

Symbol	Parameter	Conditions	Typical (Note 4)	LM4040CIM3 LM4040CIZ LM4040CIM7 Limits (Note 5)	LM4040DIM3 LM4040BIZ LM4040DIM7 Limits (Note 5)	Units (Limit)
$V_R$	Reverse Breakdown Voltage	$I_R = 100 \mu\text{A}$	5.000			V
	Reverse Breakdown Voltage Tolerance (Note 6)	$I_R = 100 \mu\text{A}$		$\pm 25$ <b><math>\pm 58</math></b>	$\pm 50$ <b><math>\pm 99</math></b>	mV (max) mV (max)
$I_{RMIN}$	Minimum Operating Current		54	74 <b>80</b>	79 <b>85</b>	$\mu\text{A}$ $\mu\text{A}$ (max) $\mu\text{A}$ (max)
		$I_R = 10 \text{ mA}$	$\pm 30$			ppm/ $^\circ\text{C}$
		$I_R = 1 \text{ mA}$ $I_R = 100 \mu\text{A}$	$\pm 20$ $\pm 20$	<b><math>\pm 100</math></b>	<b><math>\pm 150</math></b>	ppm/ $^\circ\text{C}$ (max) ppm/ $^\circ\text{C}$
$\Delta V_R / \Delta I_R$	Reverse Breakdown Voltage Change with Operating Current Change (Note 7)	$I_{RMIN} \leq I_R \leq 1 \text{ mA}$	0.5	1.0 1.4	1.3 <b>1.8</b>	mV mV (max) mV (max)
		$1 \text{ mA} \leq I_R \leq 15 \text{ mA}$	3.5	8.0 <b>12.0</b>	10.0 <b>15.0</b>	mV mV (max) mV (max)
$Z_R$	Reverse Dynamic Impedance	$I_R = 1 \text{ mA}$ , $f = 120 \text{ Hz}$ , $I_{AC} = 0.1 I_R$	0.5	1.1	1.5	$\Omega$ $\Omega$ (max)
$e_N$	Wideband Noise	$I_R = 100 \mu\text{A}$ $10 \text{ Hz} \leq f \leq 10 \text{ kHz}$	80			$\mu\text{V}_{rms}$
$\Delta V_R$	Reverse Breakdown Voltage Long Term Stability	$t = 1000 \text{ hrs}$ $T = 25^\circ\text{C} \pm 0.1^\circ\text{C}$ $I_R = 100 \mu\text{A}$	120			ppm
$V_{HYST}$	Thermal Hysteresis (Note 8)	$\Delta T = -40^\circ\text{C}$ to $+125^\circ\text{C}$	0.08			%



**LM4040-5.0****Electrical Characteristics (Extended Temperature Range)**

**Boldface limits apply for  $T_A = T_J = T_{MIN}$  to  $T_{MAX}$** ; all other limits  $T_A = T_J = 25^\circ\text{C}$ . The grades C and D designate initial Reverse Breakdown Voltage tolerances of  $\pm 0.5\%$  and  $\pm 1.0\%$ , respectively.

Symbol	Parameter	Conditions	Typical (Note 4)	LM4040CEM3 Limits (Note 5)	LM4040DEM3 Limits (Note 5)	Units (Limit)	
$V_R$	Reverse Breakdown Voltage	$I_R = 100 \mu\text{A}$	5.000			V	
	Reverse Breakdown Voltage Tolerance (Note 6)	$I_R = 100 \mu\text{A}$		$\pm 25$ <b><math>\pm 75</math></b>	$\pm 50$ <b><math>\pm 125</math></b>	mV (max) mV (max)	
$I_{RMIN}$	Minimum Operating Current		54	74 <b>83</b>	79 <b>88</b>	$\mu\text{A}$ $\mu\text{A}$ (max) $\mu\text{A}$ (max)	
		Average Reverse Breakdown Voltage Temperature Coefficient (Note 6)	$I_R = 10 \text{ mA}$ $I_R = 1 \text{ mA}$ $I_R = 100 \mu\text{A}$	$\pm 30$ $\pm 20$ $\pm 20$			ppm/ $^\circ\text{C}$ ppm/ $^\circ\text{C}$ (max) ppm/ $^\circ\text{C}$
		Reverse Breakdown Voltage Change with Operating Current Change (Note 7)	$I_{RMIN} \leq I_R \leq 1 \text{ mA}$  $1 \text{ mA} \leq I_R \leq 15 \text{ mA}$	0.5  3.5	1.0 1.4 <b>12.0</b>	1.0 <b>1.8</b> 8.0 <b>15.0</b>	mV mV (max) mV (max) mV mV (max) mV (max)
$Z_R$	Reverse Dynamic Impedance	$I_R = 1 \text{ mA}$ , $f = 120 \text{ Hz}$ , $I_{AC} = 0.1 I_R$	0.5	1.1	1.1	$\Omega$ $\Omega$ (max)	
$e_N$	Wideband Noise	$I_R = 100 \mu\text{A}$ $10 \text{ Hz} \leq f \leq 10 \text{ kHz}$	80			$\mu\text{V}_{rms}$	
$\Delta V_R$	Reverse Breakdown Voltage Long Term Stability	$t = 1000 \text{ hrs}$ $T = 25^\circ\text{C} \pm 0.1^\circ\text{C}$ $I_R = 100 \mu\text{A}$	120			ppm	
$V_{HYST}$	Thermal Hysteresis (Note 8)	$\Delta T = -40^\circ\text{C}$ to $+125^\circ\text{C}$	0.08			%	

## LM4040-8.2 Electrical Characteristics (Industrial Temperature Range)

**Boldface limits apply for  $T_A = T_J = T_{MIN}$  to  $T_{MAX}$** ; all other limits  $T_A = T_J = 25^\circ\text{C}$ . The grades A and B designate initial Reverse Breakdown Voltage tolerances of  $\pm 0.1\%$  and  $\pm 0.2\%$ , respectively.

Symbol	Parameter	Conditions	Typical (Note 4)	LM4040AIM3 LM4040AIZ Limits (Note 5)	LM4040BIM3 LM4040BIZ Limits (Note 5)	Units (Limit)
$V_R$	Reverse Breakdown Voltage	$I_R = 150 \mu\text{A}$	8.192			V
	Reverse Breakdown Voltage Tolerance (Note 6)	$I_R = 150 \mu\text{A}$		$\pm 8.2$ <b><math>\pm 61</math></b>	$\pm 16$ <b><math>\pm 70</math></b>	mV (max) mV (max)
$I_{RMIN}$	Minimum Operating Current		67	91 <b>95</b>	91 <b>95</b>	$\mu\text{A}$ $\mu\text{A}$ (max) $\mu\text{A}$ (max)
		$I_R = 10 \text{ mA}$	$\pm 40$			$\text{ppm}/^\circ\text{C}$
		$I_R = 1 \text{ mA}$ $I_R = 150 \mu\text{A}$	$\pm 20$ $\pm 20$	<b><math>\pm 100</math></b>	<b><math>\pm 100</math></b>	$\text{ppm}/^\circ\text{C}$ (max) $\text{ppm}/^\circ\text{C}$
$\Delta V_R / \Delta I_R$	Reverse Breakdown Voltage Change with Operating Current Change (Note 7)	$I_{RMIN} \leq I_R \leq 1 \text{ mA}$	0.6	1.3 <b>2.5</b>	1.3 <b>2.5</b>	mV mV (max) mV (max)
		$1 \text{ mA} \leq I_R \leq 15 \text{ mA}$	7.0	10.0 <b>18.0</b>	10.0 <b>18.0</b>	mV mV (max) mV (max)
						$\Omega$
						$\Omega$ (max)
$Z_R$	Reverse Dynamic Impedance	$I_R = 1 \text{ mA}$ , $f = 120 \text{ Hz}$ , $I_{AC} = 0.1 I_R$	0.6	1.5	1.5	$\Omega$ $\Omega$ (max)
$e_N$	Wideband Noise	$I_R = 150 \mu\text{A}$ $10 \text{ Hz} \leq f \leq 10 \text{ kHz}$	130			$\mu\text{V}_{\text{rms}}$
$\Delta V_R$	Reverse Breakdown Voltage Long Term Stability	$t = 1000 \text{ hrs}$ $T = 25^\circ\text{C} \pm 0.1^\circ\text{C}$ $I_R = 150 \mu\text{A}$	120			ppm
$V_{HYST}$	Thermal Hysteresis (Note 8)	$\Delta T = -40^\circ\text{C}$ to $+125^\circ\text{C}$	0.08			%

## LM4040-8.2 Electrical Characteristics (Industrial Temperature Range)

**Boldface limits apply for  $T_A = T_J = T_{MIN}$  to  $T_{MAX}$** ; all other limits  $T_A = T_J = 25^\circ\text{C}$ . The grades C and D designate initial Reverse Breakdown Voltage tolerances of  $\pm 0.5\%$  and  $\pm 1.0\%$ , respectively.

Symbol	Parameter	Conditions	Typical (Note 4)	LM4040CIM3 LM4040CIZ Limits (Note 5)	LM4040DIM3 LM4040DIZ Limits (Note 5)	Units (Limit)
$V_R$	Reverse Breakdown Voltage	$I_R = 150 \mu\text{A}$	8.192			V
	Reverse Breakdown Voltage Tolerance (Note 6)	$I_R = 150 \mu\text{A}$		$\pm 41$ <b><math>\pm 94</math></b>	$\pm 82$ <b><math>\pm 162</math></b>	mV (max) mV (max)
$I_{RMIN}$	Minimum Operating Current		67	91	96	$\mu\text{A}$
				<b>95</b>	<b>100</b>	$\mu\text{A}$ (max) $\mu\text{A}$ (max)
$\Delta V_R/\Delta T$	Average Reverse Breakdown Voltage Temperature Coefficient (Note 6)	$I_R = 10 \text{ mA}$	$\pm 40$			$\text{ppm}/^\circ\text{C}$
		$I_R = 1 \text{ mA}$	$\pm 20$	<b><math>\pm 100</math></b>	<b><math>\pm 150</math></b>	$\text{ppm}/^\circ\text{C}$ (max)
		$I_R = 150 \mu\text{A}$	$\pm 20$			$\text{ppm}/^\circ\text{C}$
$\Delta V_R/\Delta I_R$	Reverse Breakdown Voltage Change with Operating Current Change (Note 7)	$I_{RMIN} \leq I_R \leq 1 \text{ mA}$	0.6	1.3	1.7	mV
				<b>2.5</b>	<b>3.0</b>	mV (max) mV (max)
		$1 \text{ mA} \leq I_R \leq 15 \text{ mA}$	7.0	10.0	15.0	mV (max)
				<b>18.0</b>	<b>24.0</b>	mV (max) mV (max)
$Z_R$	Reverse Dynamic Impedance	$I_R = 1 \text{ mA}$ , $f = 120 \text{ Hz}$ , $I_{AC} = 0.1 I_R$	0.6	1.5	1.9	$\Omega$
						$\Omega$ (max)
$e_N$	Wideband Noise	$I_R = 150 \mu\text{A}$ $10 \text{ Hz} \leq f \leq 10 \text{ kHz}$	130			$\mu\text{V}_{\text{rms}}$
$\Delta V_R$	Reverse Breakdown Voltage Long Term Stability	$t = 1000 \text{ hrs}$ $T = 25^\circ\text{C} \pm 0.1^\circ\text{C}$ $I_R = 150 \mu\text{A}$	120			ppm
$V_{HYST}$	Thermal Hysteresis (Note 8)	$\Delta T = -40^\circ\text{C}$ to $+125^\circ\text{C}$	0.08			%

## LM4040-10.0 Electrical Characteristics (Industrial Temperature Range)

**Boldface limits apply for  $T_A = T_J = T_{MIN}$  to  $T_{MAX}$** ; all other limits  $T_A = T_J = 25^\circ\text{C}$ . The grades A and B designate initial Reverse Breakdown Voltage tolerances of  $\pm 0.1\%$  and  $\pm 0.2\%$ , respectively.

Symbol	Parameter	Conditions	Typical (Note 4)	LM4040AIM3 LM4040AIZ Limits (Note 5)	LM4040BIM3 LM4040BIZ Limits (Note 5)	Units (Limit)
$V_R$	Reverse Breakdown Voltage	$I_R = 150\ \mu\text{A}$	10.00			V
	Reverse Breakdown Voltage Tolerance (Note 6)	$I_R = 150\ \mu\text{A}$		$\pm 10$ <b><math>\pm 75</math></b>	$\pm 20$ <b><math>\pm 85</math></b>	mV (max) mV (max)
$I_{RMIN}$	Minimum Operating Current		75			$\mu\text{A}$
				100	100	$\mu\text{A}$ (max)
				<b>103</b>	<b>103</b>	$\mu\text{A}$ (max)
$\Delta V_R/\Delta T$	Average Reverse Breakdown Voltage Temperature Coefficient (Note 6)	$I_R = 10\ \text{mA}$	$\pm 40$			ppm/ $^\circ\text{C}$
		$I_R = 1\ \text{mA}$	$\pm 20$	<b><math>\pm 100</math></b>	<b><math>\pm 100</math></b>	ppm/ $^\circ\text{C}$ (max)
		$I_R = 150\ \mu\text{A}$	$\pm 20$			ppm/ $^\circ\text{C}$
$\Delta V_R/\Delta I_R$	Reverse Breakdown Voltage Change with Operating Current Change (Note 7)	$I_{RMIN} \leq I_R \leq 1\ \text{mA}$	0.8	1.5 <b>3.5</b>	1.5 <b>3.5</b>	mV mV (max) mV (max)
		$1\ \text{mA} \leq I_R \leq 15\ \text{mA}$	8.0	12.0 <b>23.0</b>	12.0 <b>23.0</b>	mV mV (max) mV (max)
$Z_R$	Reverse Dynamic Impedance	$I_R = 1\ \text{mA}$ , $f = 120\ \text{Hz}$ , $I_{AC} = 0.1\ I_R$	0.7			$\Omega$
				1.7	1.7	$\Omega$ (max)
$e_N$	Wideband Noise	$I_R = 150\ \mu\text{A}$ $10\ \text{Hz} \leq f \leq 10\ \text{kHz}$	180			$\mu\text{V}_{\text{rms}}$
$\Delta V_R$	Reverse Breakdown Voltage Long Term Stability	$t = 1000\ \text{hrs}$ $T = 25^\circ\text{C} \pm 0.1^\circ\text{C}$ $I_R = 150\ \mu\text{A}$	120			ppm
$V_{HYST}$	Thermal Hysteresis (Note 8)	$\Delta T = -40^\circ\text{C}$ to $+125^\circ\text{C}$	0.08			%

## LM4040-10.0 Electrical Characteristics (Industrial Temperature Range)

**Boldface limits apply for  $T_A = T_J = T_{MIN}$  to  $T_{MAX}$** ; all other limits  $T_A = T_J = 25^\circ\text{C}$ . The grades C and D designate initial Reverse Breakdown Voltage tolerances of  $\pm 0.5\%$  and  $\pm 1.0\%$ , respectively.

Symbol	Parameter	Conditions	Typical (Note 4)	LM4040CIM3 LM4040CIZ Limits (Note 5)	LM4040DIM3 LM4040DIZ Limits (Note 5)	Units (Limit)
$V_R$	Reverse Breakdown Voltage	$I_R = 150 \mu\text{A}$	10.00			V
	Reverse Breakdown Voltage Tolerance (Note 6)	$I_R = 150 \mu\text{A}$		$\pm 50$ <b><math>\pm 115</math></b>	$\pm 100$ <b><math>\pm 198</math></b>	mV (max) mV (max)
$I_{RMIN}$	Minimum Operating Current		75			$\mu\text{A}$
				100	110	$\mu\text{A}$ (max)
				<b>103</b>	<b>113</b>	$\mu\text{A}$ (max)
$\Delta V_R/\Delta T$	Average Reverse Breakdown Voltage Temperature Coefficient (Note 6)	$I_R = 10 \text{ mA}$	$\pm 40$			ppm/ $^\circ\text{C}$
		$I_R = 1 \text{ mA}$	$\pm 20$	<b><math>\pm 100</math></b>	<b><math>\pm 150</math></b>	ppm/ $^\circ\text{C}$ (max)
		$I_R = 150 \mu\text{A}$	$\pm 20$			ppm/ $^\circ\text{C}$
$\Delta V_R/\Delta I_R$	Reverse Breakdown Voltage Change with Operating Current Change (Note 7)	$I_{RMIN} \leq I_R \leq 1 \text{ mA}$	0.8	1.5 <b>3.5</b>	2.0 <b>4.0</b>	mV mV (max) mV (max)
		$1 \text{ mA} \leq I_R \leq 15 \text{ mA}$	8.0	12.0 <b>23.0</b>	18.0 <b>29.0</b>	mV mV (max) mV (max)
$Z_R$	Reverse Dynamic Impedance	$I_R = 1 \text{ mA}$ , $f = 120 \text{ Hz}$ , $I_{AC} = 0.1 I_R$	0.7	1.7	2.3	$\Omega$ $\Omega$ (max)
$e_N$	Wideband Noise	$I_R = 150 \mu\text{A}$ $10 \text{ Hz} \leq f \leq 10 \text{ kHz}$	180			$\mu\text{V}_{rms}$
$\Delta V_R$	Reverse Breakdown Voltage Long Term Stability	$t = 1000 \text{ hrs}$ $T = 25^\circ\text{C} \pm 0.1^\circ\text{C}$  $I_R = 150 \mu\text{A}$	120			ppm
$V_{HYST}$	Thermal Hysteresis (Note 8)	$\Delta T = -40^\circ\text{C}$ to $+125^\circ\text{C}$	0.08			%

## Electrical Characteristics(Notes)

**Note 1:** Absolute Maximum Ratings indicate limits beyond which damage to the device may occur. Operating Ratings indicate conditions for which the device is functional, but do not guarantee specific performance limits. For guaranteed specifications and test conditions, see the Electrical Characteristics. The guaranteed specifications apply only for the test conditions listed. Some performance characteristics may degrade when the device is not operated under the listed test conditions.

**Note 2:** The maximum power dissipation must be derated at elevated temperatures and is dictated by  $T_{Jmax}$  (maximum junction temperature),  $\theta_{JA}$  (junction to ambient thermal resistance), and  $T_A$  (ambient temperature). The maximum allowable power dissipation at any temperature is  $PD_{max} = (T_{Jmax} - T_A)/\theta_{JA}$  or the number given in the Absolute Maximum Ratings, whichever is lower. For the LM4040,  $T_{Jmax} = 125^\circ\text{C}$ , and the typical thermal resistance ( $\theta_{JA}$ ), when board mounted, is  $326^\circ\text{C/W}$  for the SOT-23 package, and  $180^\circ\text{C/W}$  with  $0.4''$  lead length and  $170^\circ\text{C/W}$  with  $0.125''$  lead length for the TO-92 package and  $415^\circ\text{C/W}$  for the SC70 Package.

**Note 3:** The human body model is a  $100\text{ pF}$  capacitor discharged through a  $1.5\text{ k}\Omega$  resistor into each pin. The machine model is a  $200\text{ pF}$  capacitor discharged directly into each pin.

**Note 4:** Typical values are at  $T_J = 25^\circ\text{C}$  and represent most likely parametric norm.

**Note 5:** Limits are 100% production tested at  $25^\circ\text{C}$ . Limits over temperature are guaranteed through correlation using Statistical Quality Control (SQC) methods. The limits are used to calculate National's AOQL.

**Note 6:** The boldface (over-temperature) limit for Reverse Breakdown Voltage Tolerance is defined as the room temperature Reverse Breakdown Voltage Tolerance  $\pm[(\Delta V_R/\Delta T)(\max\Delta T)(V_R)]$ . Where,  $\Delta V_R/\Delta T$  is the  $V_R$  temperature coefficient,  $\max\Delta T$  is the maximum difference in temperature from the reference point of  $25^\circ\text{C}$  to  $T_{MIN}$  or  $T_{MAX}$ , and  $V_R$  is the reverse breakdown voltage. The total over-temperature tolerance for the different grades in the industrial temperature range where  $\max\Delta T = 65^\circ\text{C}$  is shown below:

$$\text{A-grade: } \pm 0.75\% = \pm 0.1\% \pm 100\text{ ppm}/^\circ\text{C} \times 65^\circ\text{C}$$

$$\text{B-grade: } \pm 0.85\% = \pm 0.2\% \pm 100\text{ ppm}/^\circ\text{C} \times 65^\circ\text{C}$$

$$\text{C-grade: } \pm 1.15\% = \pm 0.5\% \pm 100\text{ ppm}/^\circ\text{C} \times 65^\circ\text{C}$$

$$\text{D-grade: } \pm 1.98\% = \pm 1.0\% \pm 150\text{ ppm}/^\circ\text{C} \times 65^\circ\text{C}$$

$$\text{E-grade: } \pm 2.98\% = \pm 2.0\% \pm 150\text{ ppm}/^\circ\text{C} \times 65^\circ\text{C}$$

The total over-temperature tolerance for the different grades in the extended temperature range where  $\max\Delta T = 100^\circ\text{C}$  is shown below:

$$\text{C-grade: } \pm 1.5\% = \pm 0.5\% \pm 100\text{ ppm}/^\circ\text{C} \times 100^\circ\text{C}$$

$$\text{D-grade: } \pm 2.5\% = \pm 1.0\% \pm 150\text{ ppm}/^\circ\text{C} \times 100^\circ\text{C}$$

$$\text{E-grade: } \pm 3.5\% = \pm 2.0\% \pm 150\text{ ppm}/^\circ\text{C} \times 100^\circ\text{C}$$

Therefore, as an example, the A-grade LM4040-2.5 has an over-temperature Reverse Breakdown Voltage tolerance of  $\pm 2.5\text{V} \times 0.75\% = \pm 19\text{ mV}$ .

**Note 7:** Load regulation is measured on pulse basis from no load to the specified load current. Output changes due to die temperature change must be taken into account separately.

**Note 8:** Thermal hysteresis is defined as the difference in voltage measured at  $+25^\circ\text{C}$  after cycling to temperature  $-40^\circ\text{C}$  and the  $25^\circ\text{C}$  measurement after cycling to temperature  $+125^\circ\text{C}$ .

# Typical Performance Characteristics

Temperature Drift for Different Average Temperature Coefficient

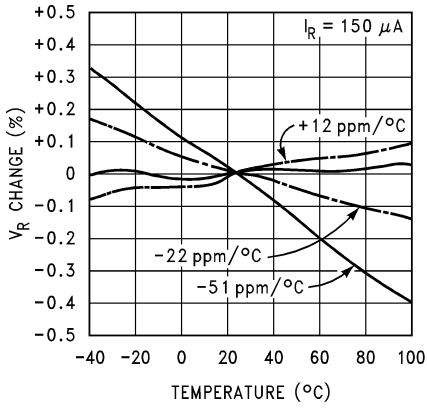

01132304

Output Impedance vs Frequency

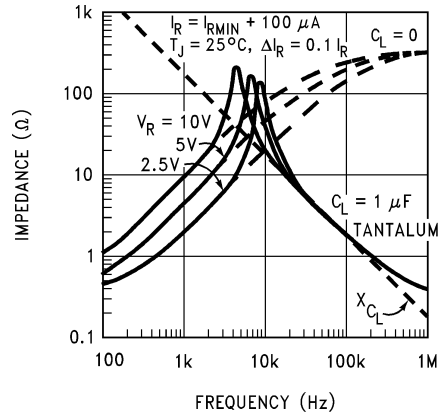

01132310

Output Impedance vs Frequency

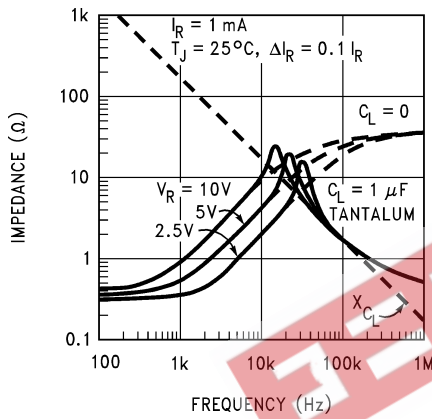

01132311

Reverse Characteristics and Minimum Operating Current

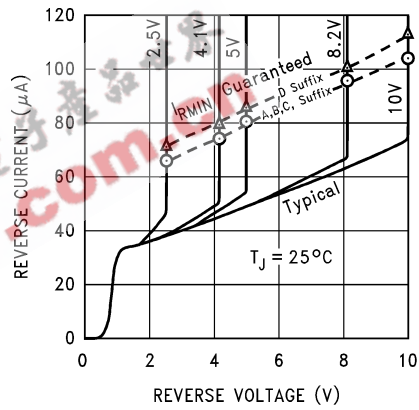

01132312

Noise Voltage vs Frequency

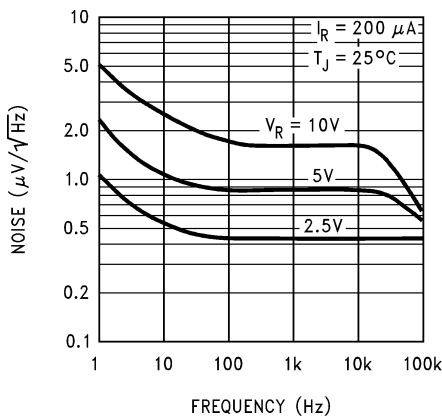

01132313

### Start-Up Characteristics

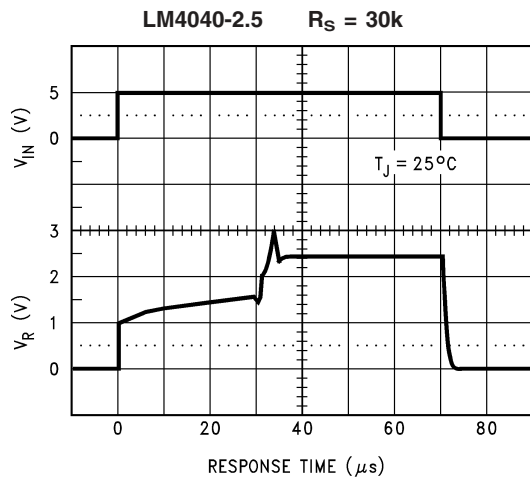
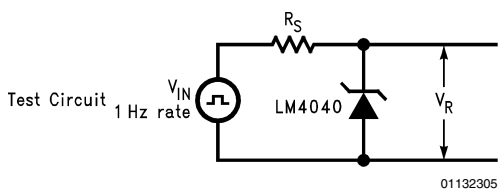

01132307

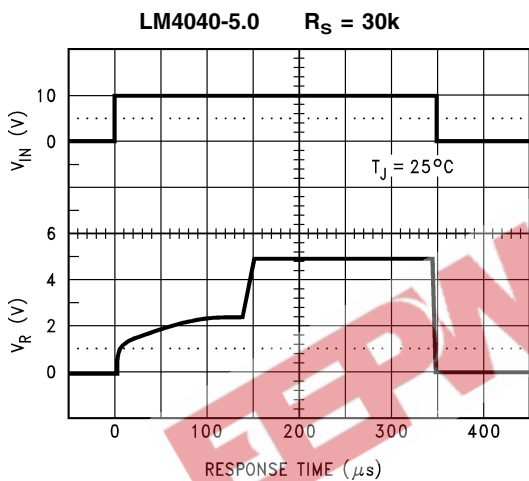

01132308

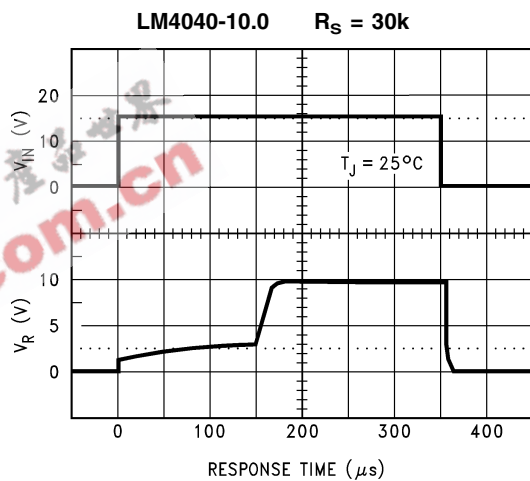

01132309

### Functional Block Diagram

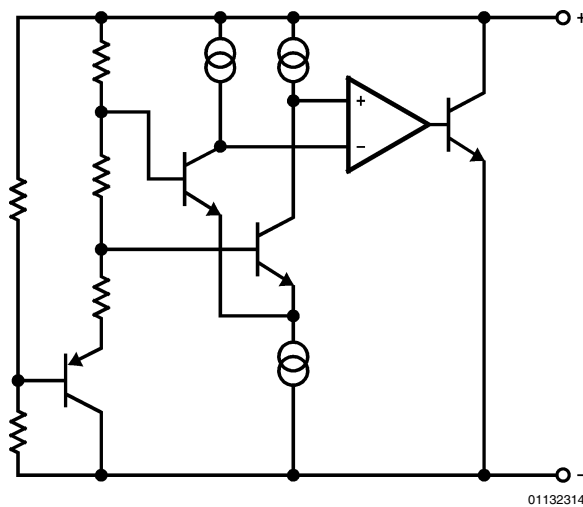



## Applications Information

The LM4040 is a precision micro-power curvature-corrected bandgap shunt voltage reference. For space critical applications, the LM4040 is available in the sub-miniature SOT-23 and SC70 surface-mount package. The LM4040 has been designed for stable operation without the need of an external capacitor connected between the “+” pin and the “-” pin. If, however, a bypass capacitor is used, the LM4040 remains stable. Reducing design effort is the availability of several fixed reverse breakdown voltages: 2.048V, 2.500V, 3.000V, 4.096V, 5.000V, 6.000, 8.192V, and 10.000V. The minimum operating current increases from 60  $\mu$ A for the LM4040-2.048 and LM4040-2.5 to 100  $\mu$ A for the LM4040-10.0. All versions have a maximum operating current of 15 mA.

LM4040s in the SOT-23 packages have a parasitic Schottky diode between pin 2 (-) and pin 3 (Die attach interface contact). Therefore, pin 3 of the SOT-23 package must be left floating or connected to pin 2.

LM4040s in the SC70 have a parasitic Schottky diode between pin 1 (-) and pin 2 (Die attach interface contact). Therefore, pin 2 must be left floating or connected to pin 1.

The 4.096V version allows single +5V 12-bit ADCs or DACs to operate with an LSB equal to 1 mV. For 12-bit ADCs or DACs that operate on supplies of 10V or greater, the 8.192V version gives 2 mV per LSB.

The typical thermal hysteresis specification is defined as the change in +25°C voltage measured after thermal cycling.

## Typical Applications

The device is thermal cycled to temperature -40°C and then measured at 25°C. Next the device is thermal cycled to temperature +125°C and again measured at 25°C. The resulting  $V_{OUT}$  delta shift between the 25°C measurements is thermal hysteresis. Thermal hysteresis is common in precision references and is induced by thermal-mechanical package stress. Changes in environmental storage temperature, operating temperature and board mounting temperature are all factors that can contribute to thermal hysteresis.

In a conventional shunt regulator application (*Figure 1*), an external series resistor ( $R_S$ ) is connected between the supply voltage and the LM4040.  $R_S$  determines the current that flows through the load ( $I_L$ ) and the LM4040 ( $I_Q$ ). Since load current and supply voltage may vary,  $R_S$  should be small enough to supply at least the minimum acceptable  $I_Q$  to the LM4040 even when the supply voltage is at its minimum and the load current is at its maximum value. When the supply voltage is at its maximum and  $I_L$  is at its minimum,  $R_S$  should be large enough so that the current flowing through the LM4040 is less than 15 mA.

$R_S$  is determined by the supply voltage, ( $V_S$ ), the load and operating current, ( $I_L$  and  $I_Q$ ), and the LM4040's reverse breakdown voltage,  $V_R$ .

$$R_S = \frac{V_S - V_R}{I_L + I_Q}$$

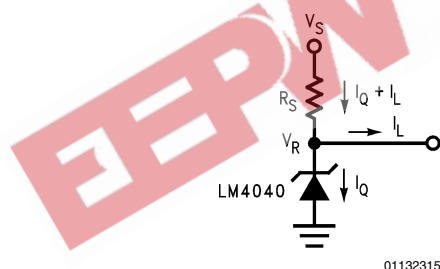

01132315

FIGURE 1. Shunt Regulator

Typical Applications (Continued)

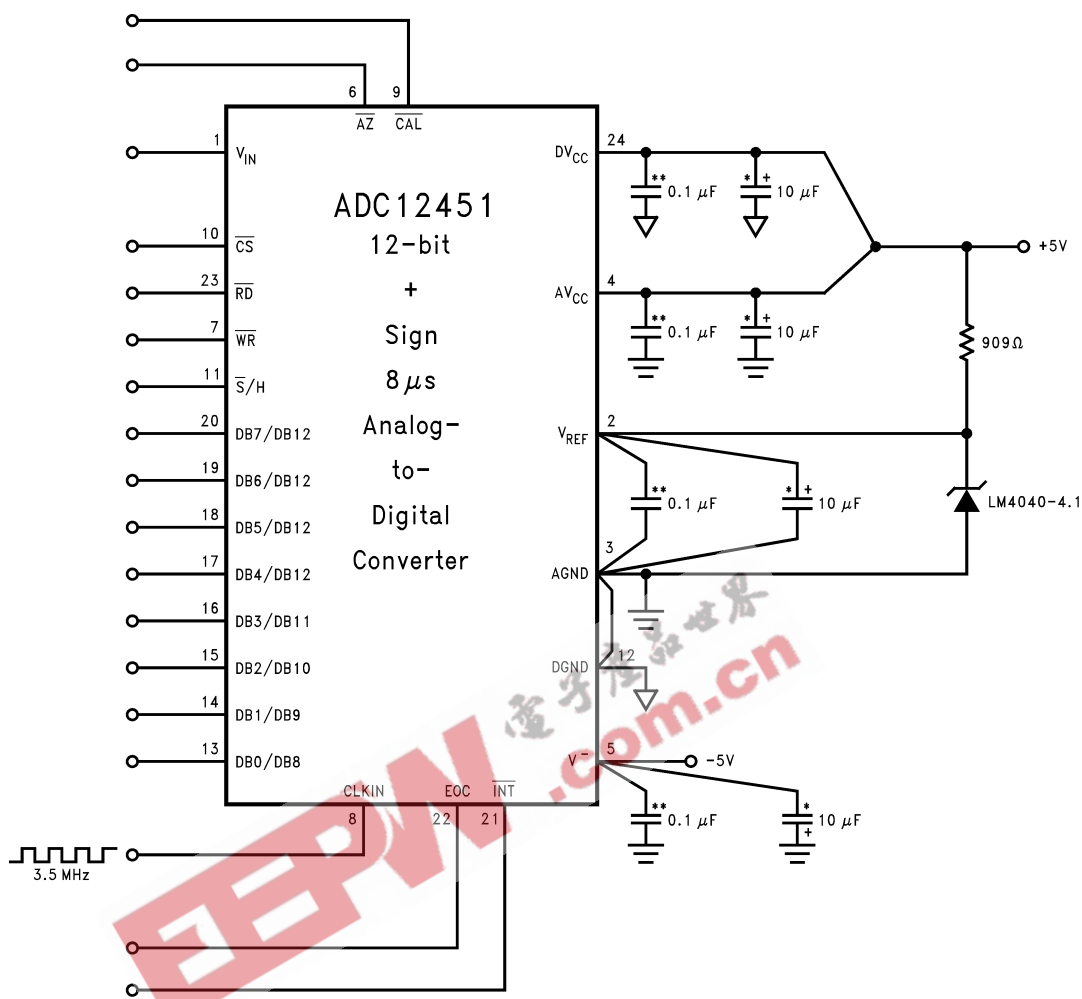

\*\*Ceramic monolithic  
\*Tantalum

01132316

FIGURE 2. LM4040-4.1's Nominal 4.096 breakdown voltage gives ADC12451 1 mV/LSB

## Typical Applications (Continued)

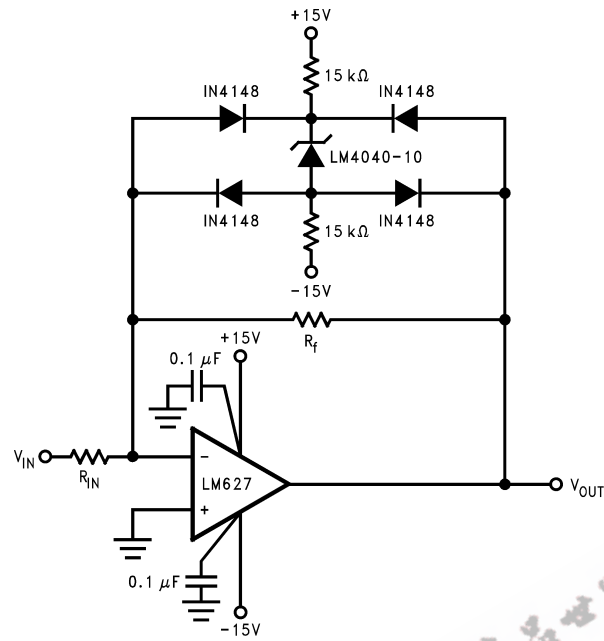

FIGURE 3. Bounded amplifier reduces saturation-induced delays and can prevent succeeding stage damage. Nominal clamping voltage is  $\pm 11.5V$  (LM4040's reverse breakdown voltage +2 diode  $V_F$ ).

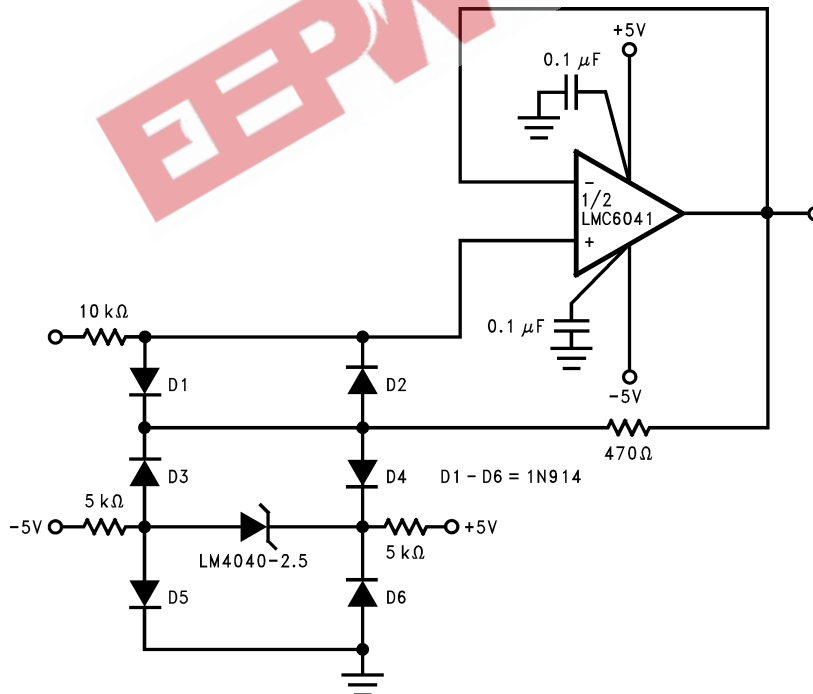
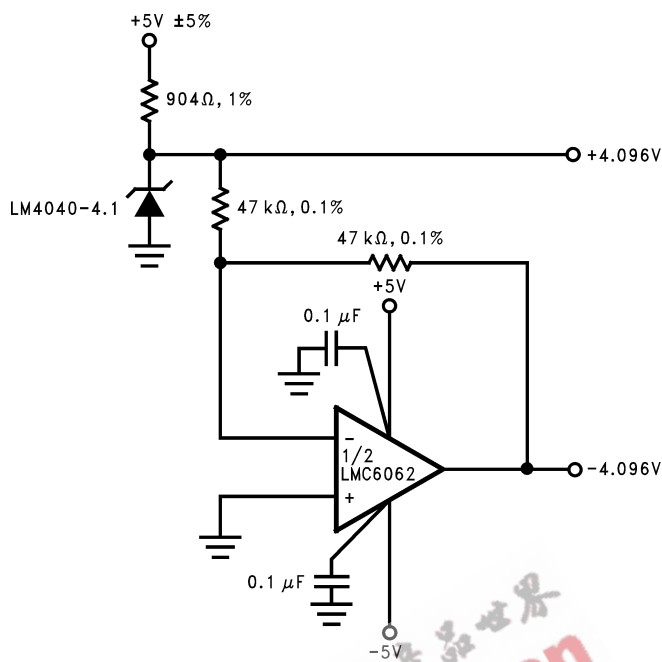

FIGURE 4. Protecting Op Amp input. The bounding voltage is  $\pm 4V$  with the LM4040-2.5 (LM4040's reverse breakdown voltage + 3 diode  $V_F$ ).

Typical Applications (Continued)



01132319

FIGURE 5. Precision ±4.096V Reference

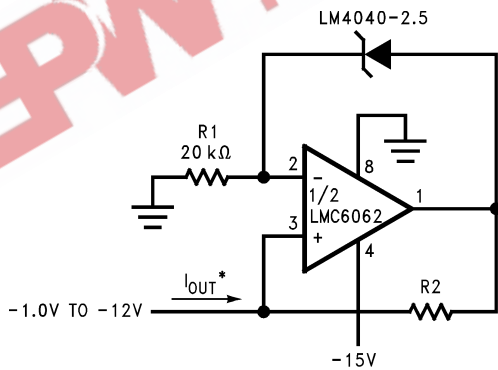

01132321

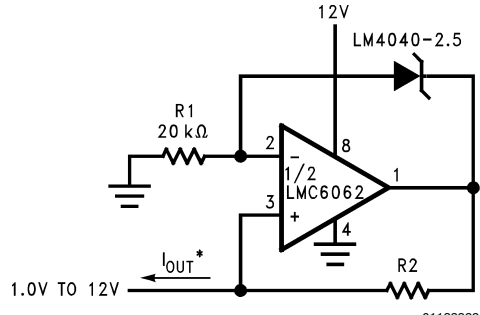

01132322

$$*I_{OUT} = \frac{2.5V}{R2}$$

FIGURE 6. Precision 1 μA to 1 mA Current Sources

**Physical Dimensions** inches (millimeters)  
unless otherwise noted

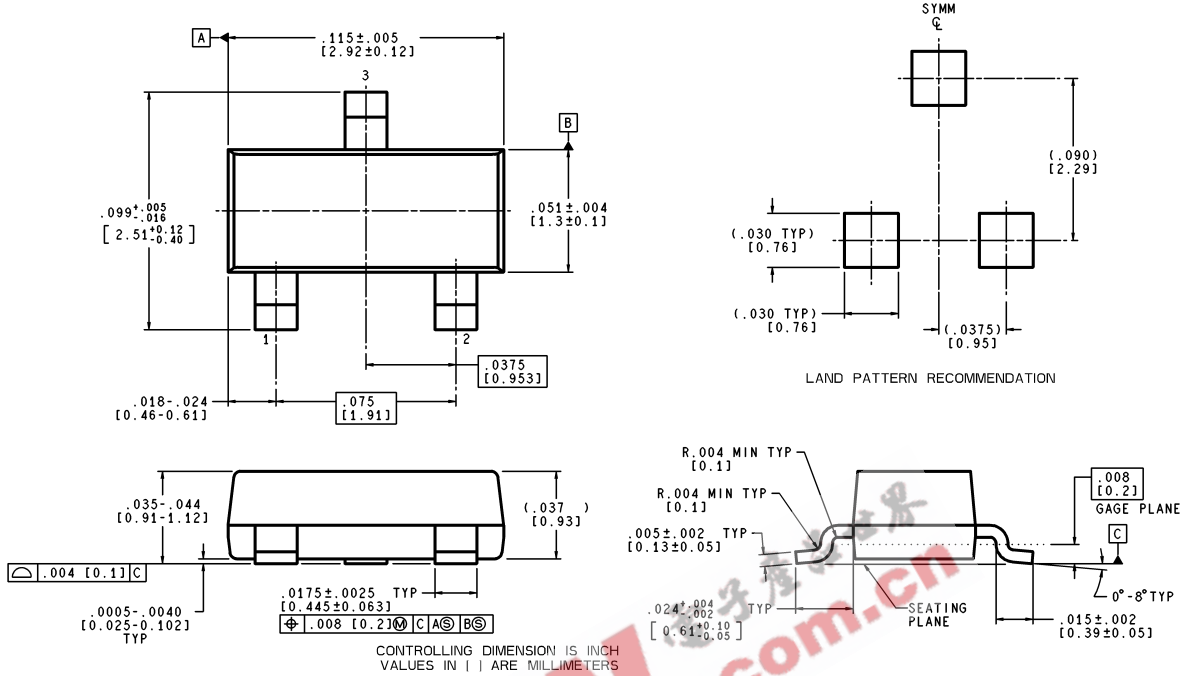

MF03A (Rev A)

**Plastic Surface Mount Package (M3)**  
**NS Package Number MF03A**  
**(JEDEC Registration TO-236AB)**

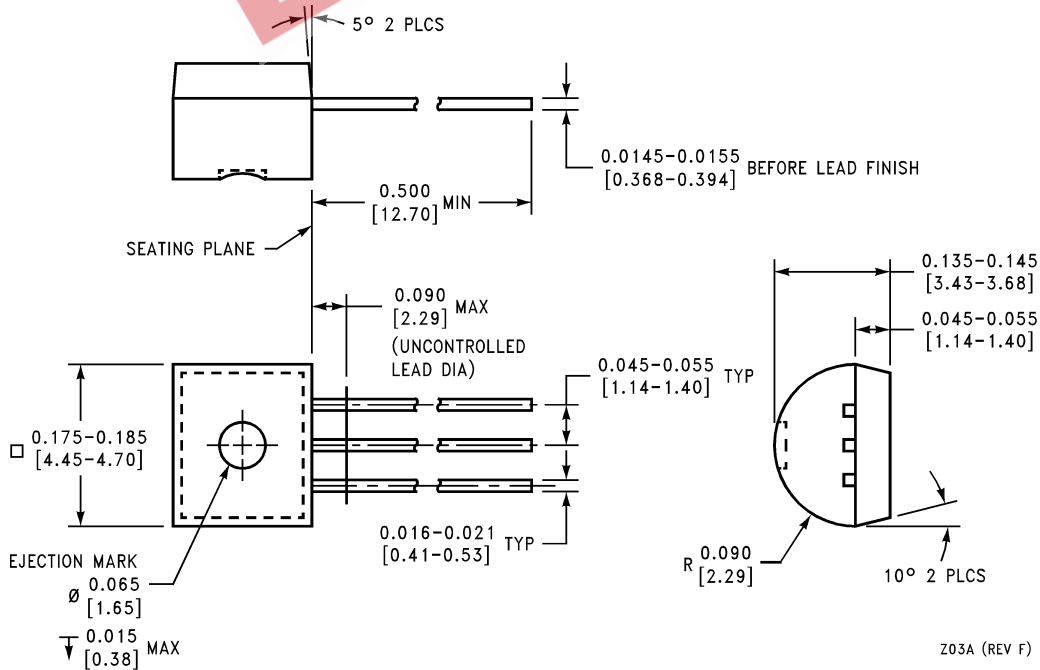

Z03A (REV F)

**Plastic Package (Z)**  
**NS Package Number Z03A**

**Physical Dimensions** inches (millimeters) unless otherwise noted (Continued)

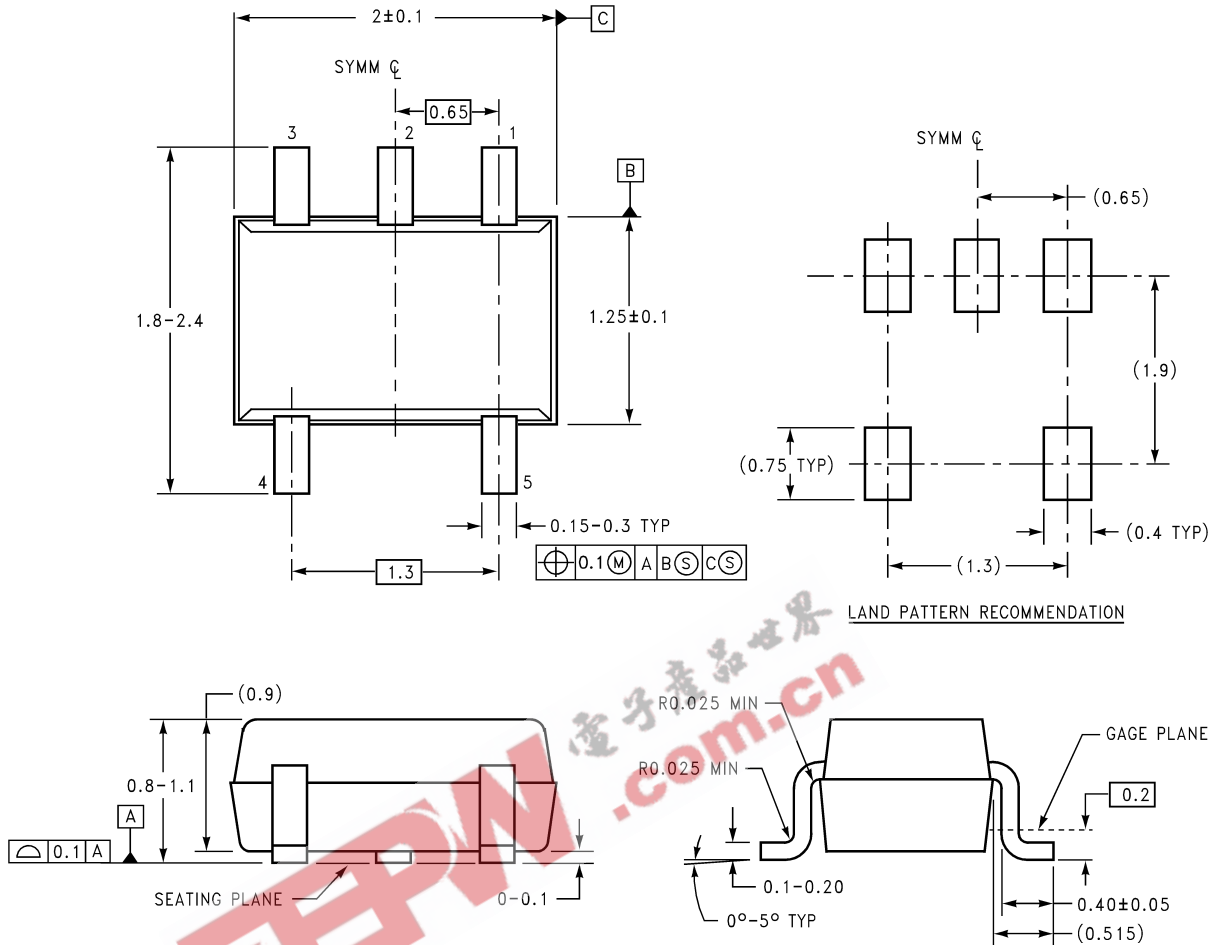

DIMENSIONS ARE IN MILLIMETERS

MAA05A (REV B)

**Molded Package (SC70)**  
**NS Package Number MAA05A**

**LIFE SUPPORT POLICY**

NATIONAL'S PRODUCTS ARE NOT AUTHORIZED FOR USE AS CRITICAL COMPONENTS IN LIFE SUPPORT DEVICES OR SYSTEMS WITHOUT THE EXPRESS WRITTEN APPROVAL OF THE PRESIDENT AND GENERAL COUNSEL OF NATIONAL SEMICONDUCTOR CORPORATION. As used herein:

1. Life support devices or systems are devices or systems which, (a) are intended for surgical implant into the body, or (b) support or sustain life, and whose failure to perform when properly used in accordance with instructions for use provided in the labeling, can be reasonably expected to result in a significant injury to the user.
2. A critical component is any component of a life support device or system whose failure to perform can be reasonably expected to cause the failure of the life support device or system, or to affect its safety or effectiveness.

 **National Semiconductor Corporation**  
Americas  
Email: support@nsc.com

www.national.com

**National Semiconductor Europe**  
Fax: +49 (0) 180-530 85 86  
Email: europe.support@nsc.com  
Deutsch Tel: +49 (0) 69 9508 6208  
English Tel: +44 (0) 870 24 0 2171  
Français Tel: +33 (0) 1 41 91 8790

**National Semiconductor Asia Pacific Customer Response Group**  
Tel: 65-2544466  
Fax: 65-2504466  
Email: ap.support@nsc.com

**National Semiconductor Japan Ltd.**  
Tel: 81-3-5639-7560  
Fax: 81-3-5639-7507