

LM139, LM139A, LM239, LM239A, LM339, LM339A, LM2901, LM2901V QUAD DIFFERENTIAL COMPARATORS

SLCS006L – OCTOBER 1979 – REVISED JUNE 2004

- Single Supply or Dual Supplies
- Wide Range of Supply Voltage:
 - Max Rating . . . 2 V to 36 V
 - Tested to 30 V . . . Non-V Devices
 - Tested to 32 V . . . V-Suffix Devices
- Low Supply-Current Drain Independent of Supply Voltage . . . 0.8 mA Typ
- Low Input Bias Current . . . 25 nA Typ
- Low Input Offset Current . . . 3 nA Typ (LM139)
- Low Input Offset Voltage . . . 2 mV Typ
- Common-Mode Input Voltage Range Includes Ground
- Differential Input Voltage Range Equal to Maximum-Rated Supply Voltage . . . ± 36 V
- Low Output Saturation Voltage
- Output Compatible With TTL, MOS, and CMOS

description/ordering information

These devices consist of four independent voltage comparators that are designed to operate from a single power supply over a wide range of voltages. Operation from dual supplies also is possible as long as the difference between the two supplies is 2 V to 36 V, and V_{CC} is at least 1.5 V more positive than the input common-mode voltage. Current drain is independent of the supply voltage. The outputs can be connected to other open-collector outputs to achieve wired-AND relationships.

The LM139 and LM139A are characterized for operation over the full military temperature range of -55°C to 125°C . The LM239 and LM239A are characterized for operation from -25°C to 125°C . The LM339 and LM339A are characterized for operation from 0°C to 70°C . The LM2901 is characterized for operation from -40°C to 125°C .

LM139, LM139A . . . D, J, OR W PACKAGE

LM239 . . . D, N, OR PW PACKAGE

LM239A . . . D PACKAGE

LM339, LM339A . . . D, DB, N, NS, OR PW PACKAGE

LM2901 . . . D, N, NS, OR PW PACKAGE

(TOP VIEW)

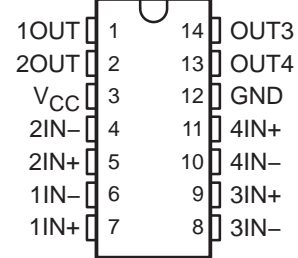

LM139, LM139A . . . FK PACKAGE

(TOP VIEW)

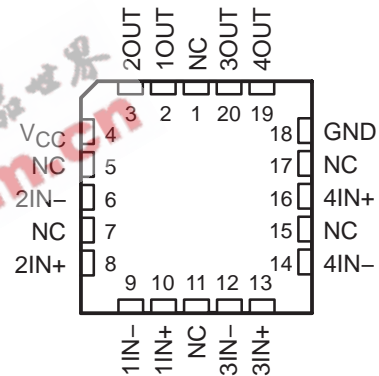

NC – No internal connection



Please be aware that an important notice concerning availability, standard warranty, and use in critical applications of Texas Instruments semiconductor products and disclaimers thereto appears at the end of this data sheet.

PRODUCTION DATA information is current as of publication date. Products conform to specifications per the terms of Texas Instruments standard warranty. Production processing does not necessarily include testing of all parameters.

 **TEXAS
INSTRUMENTS**

POST OFFICE BOX 655303 • DALLAS, TEXAS 75265

Copyright © 2004, Texas Instruments Incorporated
On products compliant to MIL-PRF-38535, all parameters are tested unless otherwise noted. On all other products, production processing does not necessarily include testing of all parameters.

**LM139, LM139A, LM239, LM239A,
LM339, LM339A, LM2901, LM2901V
QUAD DIFFERENTIAL COMPARATORS**

SLCS006L – OCTOBER 1979 – REVISED JUNE 2004

description/ordering information (continued)

ORDERING INFORMATION

T_A	V_{IOmax} AT 25°C	MAX V_{CC}	PACKAGE†		ORDERABLE PART NUMBER	TOP-SIDE MARKING
0°C to 70°C	5 mV	30 V	PDIP (N)	Tube of 25	LM339N	LM339N
			SOIC (D)	Tube of 50	LM339D	LM339
				Reel of 2500	LM339DR	
			SOP (NS)	Reel of 2000	LM339NSR	LM339
			SSOP (DB)	Reel of 2000	LM339DBR	LM339
	TSSOP (PW)	Tube of 90	LM339PW	L339		
		Reel of 2000	LM339PWR			
	2 mV	30 V	PDIP (N)	Tube of 25	LM339AN	LM339AN
			SOIC (D)	Tube of 50	LM339AD	LM339A
				Reel of 2500	LM339ADR	
SOP (NS)			Reel of 2000	LM339ANSR	LM339A	
SSOP (DB)			Reel of 2000	LM339ADBR	L339A	
TSSOP (PW)	Tube of 90	LM339APW	L339A			
	Reel of 2000	LM339APWR				
-25°C to 85°C	5 mV	30 V	PDIP (N)	Tube of 25	LM239N	LM239N
			SOIC (D)	Tube of 50	LM239D	LM239
				Reel of 2500	LM239DR	
			TSSOP (PW)	Tube of 90	LM239PW	L239
	Reel of 2000	LM239PWR				
	2 mV	30 V	SOIC (D)	Tube of 50	LM239AD	LM239A
			Reel of 2500	LM239ADR		
PDIP (N)			Tube of 25	LM2901N	LM2901N	
-40°C to 125°C	7 mV	30 V	SOIC (D)	Tube of 50	LM2901D	LM2901
			Reel of 2500	LM2901DR		
			SOP (NS)	Reel of 2000	LM2901NSR	LM2901
			TSSOP (PW)	Tube of 90	LM2901PW	L2901
	Reel of 2000	LM2901PWR				
	7 mV	32 V	SOIC (D)	Reel of 2500	LM2901VQDR	L2901V
			TSSOP (PW)	Reel of 2000	LM2901VQPWR	L2901V
		2 mV	32 V	SOIC (D)	Reel of 2500	LM2901AVQDR
TSSOP (PW)				Reel of 2000	LM2901AVQPWR	L2901AV

† Package drawings, standard packing quantities, thermal data, symbolization, and PCB design guidelines are available at www.ti.com/sc/package.

**LM139, LM139A, LM239, LM239A,
LM339, LM339A, LM2901, LM2901V
QUAD DIFFERENTIAL COMPARATORS**

SLCS006L – OCTOBER 1979 – REVISED JUNE 2004

description/ordering information (continued)

ORDERING INFORMATION

T _A	V _{IO} max AT 25°C	MAX V _{CC}	PACKAGE†		ORDERABLE PART NUMBER	TOP-SIDE MARKING
–55°C to 125°C	5 mV	30 V	CFP (W)	Tube of 25	LM139W	LM139W
			CDIP (J)	Tube of 25	LM139J	LM139J
			LCCC (FK)	Tube of 55	LM139FK	LM139FK
			SOIC (D)	Tube of 50	LM139D	LM139D
	Reel of 2500	LM139DR				
	2 mV	30 V	CFP (W)	Tube of 25	LM139AW	LM139AW
			CDIP (J)	Tube of 25	LM139AJ	LM139AJ
			LCCC (FK)	Tube of 55	LM139AFK	LM139AFK
SOIC (D)			Tube of 50	LM139AD	LM139AD	
	Reel of 2500	LM139ADR				

† Package drawings, standard packing quantities, thermal data, symbolization, and PCB design guidelines are available at www.ti.com/sc/package.

symbol (each comparator)



schematic (each comparator)

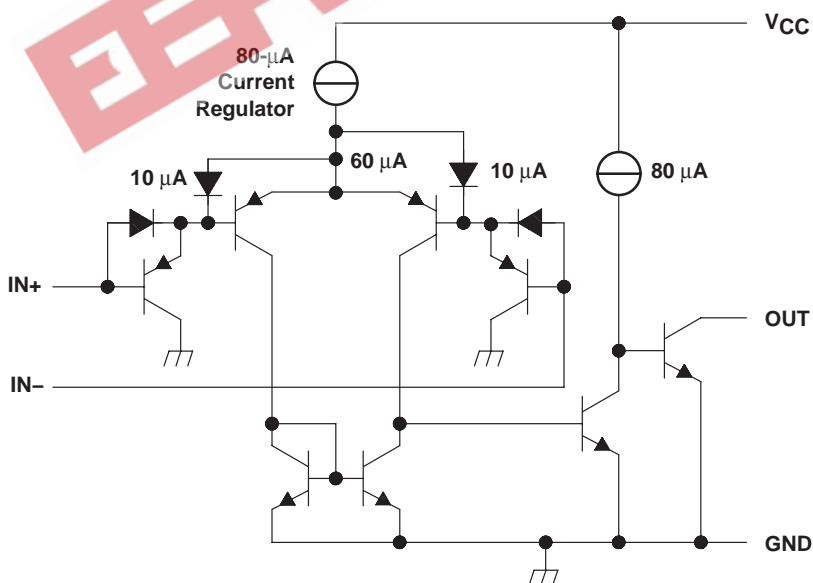

All current values shown are nominal.

LM139, LM139A, LM239, LM239A, LM339, LM339A, LM2901, LM2901V QUAD DIFFERENTIAL COMPARATORS

SLCS006L – OCTOBER 1979 – REVISED JUNE 2004

absolute maximum ratings over operating free-air temperature range (unless otherwise noted)†

Supply voltage, V_{CC} (see Note 1)	36 V
Differential input voltage, V_{ID} (see Note 2)	± 36 V
Input voltage range, V_I (either input)	-0.3 V to 36 V
Output voltage, V_O	36 V
Output current, I_O	20 mA
Duration of output short circuit to ground (see Note 3)	Unlimited
Package thermal impedance, θ_{JA} (see Notes 4 and 5):	
D package	86°C/W
DB package	96°C/W
N package	80°C/W
NS package	76°C/W
PW package	113°C/W
Package thermal impedance, θ_{JC} (see Notes 6 and 7):	
FK package	5.61°C/W
J package	15.05°C/W
W package	14.65°C/W
Operating virtual junction temperature, T_J	150°C
Case temperature for 60 seconds: FK package	260°C
Lead temperature 1,6 mm (1/16 inch) from case for 60 seconds: J package	300°C
Storage temperature range, T_{stg}	-65°C to 150°C

† Stresses beyond those listed under “absolute maximum ratings” may cause permanent damage to the device. These are stress ratings only, and functional operation of the device at these or any other conditions beyond those indicated under “recommended operating conditions” is not implied. Exposure to absolute-maximum-rated conditions for extended periods may affect device reliability.

- NOTES:
- All voltage values, except differential voltages, are with respect to network ground.
 - Differential voltages are at $IN+$ with respect to $IN-$.
 - Short circuits from outputs to V_{CC} can cause excessive heating and eventual destruction.
 - Maximum power dissipation is a function of $T_J(\max)$, θ_{JA} , and T_A . The maximum allowable power dissipation at any allowable ambient temperature is $P_D = (T_J(\max) - T_A) / \theta_{JA}$. Operating at the absolute maximum T_J of 150°C can affect reliability.
 - The package thermal impedance is calculated in accordance with JESD 51-7.
 - Maximum power dissipation is a function of $T_J(\max)$, θ_{JC} , and T_C . The maximum allowable power dissipation at any allowable case temperature is $P_D = (T_J(\max) - T_C) / \theta_{JC}$. Operating at the absolute maximum T_J of 150°C can affect reliability.
 - The package thermal impedance is calculated in accordance with MIL-STD-883.

**LM139, LM139A, LM239, LM239A,
LM339, LM339A, LM2901, LM2901V**

SLCS006L – OCTOBER 1979 – REVISED JUNE 2004

electrical characteristics at specified free-air temperature, $V_{CC} = 5\text{ V}$ (unless otherwise noted)

PARAMETER	TEST CONDITION [†]	T_A [‡]	LM139			LM139A			UNIT
			MIN	TYP	MAX	MIN	TYP	MAX	
V_{IO} Input offset voltage	$V_{CC} = 5\text{ V to }30\text{ V}$, $V_{IC} = V_{ICR(\text{min})}$, $V_O = 1.4\text{ V}$	25°C		2	5		1	2	mV
		Full range			9			4	
I_{IO} Input offset current	$V_O = 1.4\text{ V}$	25°C		3	25		3	25	nA
		Full range			100			100	
I_{IB} Input bias current	$V_O = 1.4\text{ V}$	25°C		-25	-100		-25	-100	nA
		Full range			-300			-300	
V_{ICR} Common-mode input-voltage range		25°C		0 to $V_{CC}-1.5$		0 to $V_{CC}-1.5$			V
		Full range		0 to $V_{CC}-2$		0 to $V_{CC}-2$			
A_{VD} Large-signal differential-voltage amplification	$V_{CC} \pm = \pm 7.5\text{ V}$, $V_O = -5\text{ V to }5\text{ V}$	25°C		200		50	200	V/mV	
I_{OH} High-level output current	$V_{ID} = 1\text{ V}$	$V_{OH} = 5\text{ V}$	25°C		0.1		0.1	nA	
		$V_{OH} = 30\text{ V}$	Full range			1		1	μA
V_{OL} Low-level output voltage	$V_{ID} = -1\text{ V}$, $I_{OL} = 4\text{ mA}$	25°C		150	400		150	400	mV
		Full range			700			700	
I_{OL} Low-level output current	$V_{ID} = -1\text{ V}$, $V_{OL} = 1.5\text{ V}$	25°C		6	16		6	16	mA
I_{CC} Supply current (four comparators)	$V_O = 2.5\text{ V}$, No load	25°C		0.8	2		0.8	2	mA

[†] All characteristics are measured with zero common-mode input voltage, unless otherwise specified.

[‡] Full range (MIN to MAX) for LM139 and LM139A is -55°C to 125°C . All characteristics are measured with zero common-mode input voltage, unless otherwise specified.

switching characteristics, $V_{CC} = 5\text{ V}$, $T_A = 25^\circ\text{C}$

PARAMETER	TEST CONDITIONS	LM139 LM139A			UNIT
		MIN	TYP	MAX	
Response time	R_L connected to 5 V through 5.1 k Ω , $C_L = 15\text{ pF}$ [§] , See Note 8	100-mV input step with 5-mV overdrive			1.3
		TTL-level input step			0.3

[§] C_L includes probe and jig capacitance.

NOTE 8: The response time specified is the interval between the input step function and the instant when the output crosses 1.4 V.

LM139, LM139A, LM239, LM239A, LM339, LM339A, LM2901, LM2901V QUAD DIFFERENTIAL COMPARATORS

SLCS006L – OCTOBER 1979 – REVISED JUNE 2004

electrical characteristics at specified free-air temperature, $V_{CC} = 5\text{ V}$ (unless otherwise noted)

PARAMETER	TEST CONDITIONS†	T_A ‡	LM239 LM339			LM239A LM339A			UNIT
			MIN	TYP	MAX	MIN	TYP	MAX	
V_{IO} Input offset voltage	$V_{CC} = 5\text{ V to }30\text{ V}$, $V_{IC} = V_{ICR(\text{min})}$, $V_O = 1.4\text{ V}$	25°C	2		5	1		3	mV
		Full range	9			4			
I_{IO} Input offset current	$V_O = 1.4\text{ V}$	25°C	5		50	5		50	nA
		Full range	150			150			
I_{IB} Input bias current	$V_O = 1.4\text{ V}$	25°C	-25		-250	-25		-250	nA
		Full range	-400			-400			
V_{ICR} Common-mode input-voltage range		25°C	0 to $V_{CC}-1.5$			0 to $V_{CC}-1.5$			V
		Full range	0 to $V_{CC}-2$			0 to $V_{CC}-2$			
AV_D Large-signal differential-voltage amplification	$V_{CC} = 15\text{ V}$, $V_O = 1.4\text{ V to }11.4\text{ V}$, $R_L \geq 15\text{ k}\Omega\text{ to }V_{CC}$	25°C	50	200		50	200		V/mV
I_{OH} High-level output current	$V_{ID} = 1\text{ V}$	$V_{OH} = 5\text{ V}$	25°C	0.1	50	0.1	50	nA	
		$V_{OH} = 30\text{ V}$	Full range	1			1		μA
V_{OL} Low-level output voltage	$V_{ID} = -1\text{ V}$, $I_{OL} = 4\text{ mA}$	25°C	150		400	150	400	mV	
		Full range	700			700			
I_{OL} Low-level output current	$V_{ID} = -1\text{ V}$, $V_{OL} = 1.5\text{ V}$	25°C	6	16		6	16	mA	
I_{CC} Supply current (four comparators)	$V_O = 2.5\text{ V}$, No load	25°C	0.8		2	0.8	2	mA	

† All characteristics are measured with zero common-mode input voltage, unless otherwise specified.

‡ Full range (MIN to MAX) for LM239 and LM239A is -25°C to 85°C , for LM339 and LM339A is 0°C to 70°C . All characteristics are measured with zero common-mode input voltage, unless otherwise specified.

switching characteristics, $V_{CC} = 5\text{ V}$, $T_A = 25^\circ\text{C}$

PARAMETER	TEST CONDITIONS	LM239, LM239A, LM339, LM339A			UNIT
		MIN	TYP	MAX	
Response time	R_L connected to 5 V through 5.1 k Ω , $C_L = 15\text{ pF}$ §, See Note 8	100-mV input step with 5-mV overdrive			μs
		TTL-level input step			

§ C_L includes probe and jig capacitance.

NOTE 8: The response time specified is the interval between the input step function and the instant when the output crosses 1.4 V.

**LM139, LM139A, LM239, LM239A,
LM339, LM339A, LM2901, LM2901V**
QUAD DIFFERENTIAL COMPARATORS

SLCS006L – OCTOBER 1979 – REVISED JUNE 2004

electrical characteristics at specified free-air temperature, $V_{CC} = 5\text{ V}$ (unless otherwise noted)

PARAMETER	TEST CONDITIONS†		T_A ‡	LM2901			UNIT
				MIN	TYP	MAX	
V_{IO} Input offset voltage	$V_{IC} = V_{ICR}(\text{min})$, $V_O = 1.4\text{ V}$, $V_{CC} = 5\text{ V to MAX}\S$	Non-A devices	25°C	2	7	mV	
			Full range		15		
		A-suffix devices	25°C	1	2		
			Full range		4		
I_{IO} Input offset current	$V_O = 1.4\text{ V}$		25°C	5	50	nA	
			Full range		200		
I_{IB} Input bias current	$V_O = 1.4\text{ V}$		25°C	-25	-250	nA	
			Full range		-500		
V_{ICR} Common-mode input-voltage range			25°C	0 to $V_{CC}-1.5$		V	
			Full range	0 to $V_{CC}-2$			
A_{VD} Large-signal differential-voltage amplification	$V_{CC} = 15\text{ V}$, $V_O = 1.4\text{ V to }11.4\text{ V}$, $R_L \geq 15\text{ k}\Omega\text{ to }V_{CC}$		25°C	25	100	V/mV	
I_{OH} High-level output current	$V_{ID} = 1\text{ V}$		$V_{OH} = 5\text{ V}$	25°C	0.1	50	nA
			$V_{OH} = V_{CC}\text{ MAX}\S$	Full range		1	μA
V_{OL} Low-level output voltage	$V_{ID} = -1\text{ V}$, $I_{OL} = 4\text{ mA}$		Non-V devices	25°C	150	500	mV
			V-suffix devices		150	400	
			All devices		Full range		
I_{OL} Low-level output current	$V_{ID} = -1\text{ V}$, $V_{OL} = 1.5\text{ V}$		25°C	6	16	mA	
I_{CC} Supply current (four comparators)	$V_O = 2.5\text{ V}$, No load		$V_{CC} = 5\text{ V}$	25°C	0.8	2	mA
			$V_{CC} = \text{MAX}\S$		1	2.5	

† All characteristics are measured with zero common-mode input voltage, unless otherwise specified.

‡ Full range (MIN to MAX) for LM2901 is -40°C to 125°C . All characteristics are measured with zero common-mode input voltage, unless otherwise specified.

§ $V_{CC}\text{ MAX} = 30\text{ V}$ for non-V devices, and 32 V for V-suffix devices.

switching characteristics, $V_{CC} = 5\text{ V}$, $T_A = 25^\circ\text{C}$

PARAMETER	TEST CONDITIONS		LM2901			UNIT
			MIN	TYP	MAX	
Response time	R_L connected to 5 V through $5.1\text{ k}\Omega$, $C_L = 15\text{ pF}$ ¶, See Note 8		100-mV input step with 5-mV overdrive		1.3	μs
			TTL-level input step		0.3	

¶ C_L includes probe and jig capacitance.

NOTE 8: The response time specified is the interval between the input step function and the instant when the output crosses 1.4 V .

PACKAGING INFORMATION

Orderable Device	Status ⁽¹⁾	Package Type	Package Drawing	Pins	Package Qty	Eco Plan ⁽²⁾	Lead/Ball Finish	MSL Peak Temp ⁽³⁾
5962-7700801VCA	ACTIVE	CDIP	J	14	1	None	A42 SNPB	Level-NC-NC-NC
5962-87739012A	ACTIVE	LCCC	FK	20	1	None	POST-PLATE	Level-NC-NC-NC
5962-8773901CA	ACTIVE	CDIP	J	14	1	None	A42 SNPB	Level-NC-NC-NC
5962-8773901DA	ACTIVE	CFP	W	14	1	None	A42 SNPB	Level-NC-NC-NC
77008012A	ACTIVE	LCCC	FK	20	1	None	POST-PLATE	Level-NC-NC-NC
7700801CA	ACTIVE	CDIP	J	14	1	None	A42 SNPB	Level-NC-NC-NC
7700801DA	ACTIVE	CFP	W	14	1	None	A42 SNPB	Level-NC-NC-NC
JM38510/11201BCA	ACTIVE	CDIP	J	14	1	None	A42 SNPB	Level-NC-NC-NC
LM139AD	ACTIVE	SOIC	D	14	50	None	CU NIPDAU	Level-3-245C-168 HR
LM139ADR	ACTIVE	SOIC	D	14	2500	Pb-Free (RoHS)	CU NIPDAU	Level-2-250C-1 YEAR/ Level-1-235C-UNLIM
LM139AFKB	ACTIVE	LCCC	FK	20	1	None	POST-PLATE	Level-NC-NC-NC
LM139AJ	ACTIVE	CDIP	J	14	1	None	A42 SNPB	Level-NC-NC-NC
LM139AJB	ACTIVE	CDIP	J	14	1	None	A42 SNPB	Level-NC-NC-NC
LM139AN	OBSOLETE	PDIP	N	14		None	Call TI	Call TI
LM139AW	ACTIVE	CFP	W	14	1	None	A42 SNPB	Level-NC-NC-NC
LM139AWB	ACTIVE	CFP	W	14	1	None	A42 SNPB	Level-NC-NC-NC
LM139D	ACTIVE	SOIC	D	14	50	None	CU NIPDAU	Level-1-220C-UNLIM
LM139DR	ACTIVE	SOIC	D	14	2500	None	CU NIPDAU	Level-1-220C-UNLIM
LM139FKB	ACTIVE	LCCC	FK	20	1	None	POST-PLATE	Level-NC-NC-NC
LM139J	ACTIVE	CDIP	J	14	1	None	A42 SNPB	Level-NC-NC-NC
LM139JB	ACTIVE	CDIP	J	14	1	None	A42 SNPB	Level-NC-NC-NC
LM139N	OBSOLETE	PDIP	N	14		None	Call TI	Call TI
LM139W	ACTIVE	CFP	W	14	1	None	A42 SNPB	Level-NC-NC-NC
LM139WB	ACTIVE	CFP	W	14	1	None	A42 SNPB	Level-NC-NC-NC
LM239AD	ACTIVE	SOIC	D	14	50	Pb-Free (RoHS)	CU NIPDAU	Level-2-260C-1 YEAR/ Level-1-235C-UNLIM
LM239ADR	ACTIVE	SOIC	D	14	2500	Pb-Free (RoHS)	CU NIPDAU	Level-2-260C-1 YEAR/ Level-1-235C-UNLIM
LM239AN	OBSOLETE	PDIP	N	14		None	Call TI	Call TI
LM239D	ACTIVE	SOIC	D	14	50	Pb-Free (RoHS)	CU NIPDAU	Level-2-260C-1 YEAR/ Level-1-235C-UNLIM
LM239DR	ACTIVE	SOIC	D	14	2500	Pb-Free (RoHS)	CU NIPDAU	Level-2-260C-1 YEAR/ Level-1-235C-UNLIM
LM239N	ACTIVE	PDIP	N	14	25	Pb-Free (RoHS)	CU NIPDAU	Level-NC-NC-NC
LM239PW	ACTIVE	TSSOP	PW	14	90	Pb-Free (RoHS)	CU NIPDAU	Level-1-250C-UNLIM
LM239PWR	ACTIVE	TSSOP	PW	14	2000	Pb-Free (RoHS)	CU NIPDAU	Level-1-250C-UNLIM
LM2901AVQDR	ACTIVE	SOIC	D	14	2500	Pb-Free (RoHS)	CU NIPDAU	Level-2-250C-1 YEAR/ Level-1-235C-UNLIM
LM2901AVQPWR	ACTIVE	TSSOP	PW	14	2000	None	CU NIPDAU	Level-1-250C-UNLIM
LM2901D	ACTIVE	SOIC	D	14	50	Pb-Free (RoHS)	CU NIPDAU	Level-2-260C-1 YEAR/ Level-1-235C-UNLIM

Orderable Device	Status ⁽¹⁾	Package Type	Package Drawing	Pins	Package Qty	Eco Plan ⁽²⁾	Lead/Ball Finish	MSL Peak Temp ⁽³⁾
LM2901DR	ACTIVE	SOIC	D	14	2500	Pb-Free (RoHS)	CU NIPDAU	Level-2-260C-1 YEAR/ Level-1-235C-UNLIM
LM2901N	ACTIVE	PDIP	N	14	25	Pb-Free (RoHS)	CU NIPDAU	Level-NC-NC-NC
LM2901NSR	ACTIVE	SO	NS	14	2000	Pb-Free (RoHS)	CU NIPDAU	Level-2-260C-1 YEAR/ Level-1-235C-UNLIM
LM2901PW	ACTIVE	TSSOP	PW	14	90	Pb-Free (RoHS)	CU NIPDAU	Level-1-250C-UNLIM
LM2901PWLE	OBSOLETE	TSSOP	PW	14		None	Call TI	Call TI
LM2901PWR	ACTIVE	TSSOP	PW	14	2000	Pb-Free (RoHS)	CU NIPDAU	Level-1-250C-UNLIM
LM2901QD	OBSOLETE	SOIC	D	14		None	Call TI	Call TI
LM2901QN	OBSOLETE	PDIP	N	14		None	Call TI	Call TI
LM2901VQDR	ACTIVE	SOIC	D	14	2500	Pb-Free (RoHS)	CU NIPDAU	Level-2-250C-1 YEAR/ Level-1-235C-UNLIM
LM2901VQPWR	ACTIVE	TSSOP	PW	14	2000	None	CU NIPDAU	Level-1-250C-UNLIM
LM339AD	ACTIVE	SOIC	D	14	50	Pb-Free (RoHS)	CU NIPDAU	Level-2-260C-1 YEAR/ Level-1-235C-UNLIM
LM339ADBR	ACTIVE	SSOP	DB	14	2000	Pb-Free (RoHS)	CU NIPDAU	Level-2-260C-1 YEAR/ Level-1-235C-UNLIM
LM339ADR	ACTIVE	SOIC	D	14	2500	Pb-Free (RoHS)	CU NIPDAU	Level-2-260C-1 YEAR/ Level-1-235C-UNLIM
LM339AN	ACTIVE	PDIP	N	14	25	Pb-Free (RoHS)	CU NIPDAU	Level-NC-NC-NC
LM339ANSR	ACTIVE	SO	NS	14	2000	Pb-Free (RoHS)	CU NIPDAU	Level-2-260C-1 YEAR/ Level-1-235C-UNLIM
LM339APW	ACTIVE	TSSOP	PW	14	90	Pb-Free (RoHS)	CU NIPDAU	Level-1-250C-UNLIM
LM339APWR	ACTIVE	TSSOP	PW	14	2000	Pb-Free (RoHS)	CU NIPDAU	Level-1-250C-UNLIM
LM339D	ACTIVE	SOIC	D	14	50	Pb-Free (RoHS)	CU NIPDAU	Level-2-260C-1 YEAR/ Level-1-235C-UNLIM
LM339DBLE	OBSOLETE	SSOP	DB	14		None	Call TI	Call TI
LM339DBR	ACTIVE	SSOP	DB	14	2000	Pb-Free (RoHS)	CU NIPDAU	Level-2-260C-1 YEAR/ Level-1-235C-UNLIM
LM339DR	ACTIVE	SOIC	D	14	2500	Pb-Free (RoHS)	CU NIPDAU	Level-2-260C-1 YEAR/ Level-1-235C-UNLIM
LM339N	ACTIVE	PDIP	N	14	25	Pb-Free (RoHS)	CU NIPDAU	Level-NC-NC-NC
LM339NSLE	OBSOLETE	SO	NS	14		None	Call TI	Call TI
LM339NSR	ACTIVE	SO	NS	14	2000	Pb-Free (RoHS)	CU NIPDAU	Level-2-260C-1 YEAR/ Level-1-235C-UNLIM
LM339PW	ACTIVE	TSSOP	PW	14	90	Pb-Free (RoHS)	CU NIPDAU	Level-1-250C-UNLIM
LM339PWLE	OBSOLETE	TSSOP	PW	14		None	Call TI	Call TI
LM339PWR	ACTIVE	TSSOP	PW	14	2000	Pb-Free (RoHS)	CU NIPDAU	Level-1-250C-UNLIM
LM339Y	OBSOLETE			0		None	Call TI	Call TI

⁽¹⁾ The marketing status values are defined as follows:

ACTIVE: Product device recommended for new designs.

LIFEBUY: TI has announced that the device will be discontinued, and a lifetime-buy period is in effect.

NRND: Not recommended for new designs. Device is in production to support existing customers, but TI does not recommend using this part in a new design.

PREVIEW: Device has been announced but is not in production. Samples may or may not be available.

OBSOLETE: TI has discontinued the production of the device.

⁽²⁾ Eco Plan - May not be currently available - please check <http://www.ti.com/productcontent> for the latest availability information and additional product content details.

None: Not yet available Lead (Pb-Free).

Pb-Free (RoHS): TI's terms "Lead-Free" or "Pb-Free" mean semiconductor products that are compatible with the current RoHS requirements for all 6 substances, including the requirement that lead not exceed 0.1% by weight in homogeneous materials. Where designed to be soldered at high temperatures, TI Pb-Free products are suitable for use in specified lead-free processes.

Green (RoHS & no Sb/Br): TI defines "Green" to mean "Pb-Free" and in addition, uses package materials that do not contain halogens, including bromine (Br) or antimony (Sb) above 0.1% of total product weight.

⁽³⁾ MSL, Peak Temp. -- The Moisture Sensitivity Level rating according to the JEDEC industry standard classifications, and peak solder temperature.

Important Information and Disclaimer: The information provided on this page represents TI's knowledge and belief as of the date that it is provided. TI bases its knowledge and belief on information provided by third parties, and makes no representation or warranty as to the accuracy of such information. Efforts are underway to better integrate information from third parties. TI has taken and continues to take reasonable steps to provide representative and accurate information but may not have conducted destructive testing or chemical analysis on incoming materials and chemicals. TI and TI suppliers consider certain information to be proprietary, and thus CAS numbers and other limited information may not be available for release.

In no event shall TI's liability arising out of such information exceed the total purchase price of the TI part(s) at issue in this document sold by TI to Customer on an annual basis.

J (R-GDIP-T**)
 14 LEADS SHOWN

CERAMIC DUAL IN-LINE PACKAGE



DIM \ PINS **	14	16	18	20
A	0.300 (7,62) BSC	0.300 (7,62) BSC	0.300 (7,62) BSC	0.300 (7,62) BSC
B MAX	0.785 (19,94)	.840 (21,34)	0.960 (24,38)	1.060 (26,92)
B MIN	—	—	—	—
C MAX	0.300 (7,62)	0.300 (7,62)	0.310 (7,87)	0.300 (7,62)
C MIN	0.245 (6,22)	0.245 (6,22)	0.220 (5,59)	0.245 (6,22)



4040083/F 03/03

- NOTES:
- A. All linear dimensions are in inches (millimeters).
 - B. This drawing is subject to change without notice.
 - C. This package is hermetically sealed with a ceramic lid using glass frit.
 - D. Index point is provided on cap for terminal identification only on press ceramic glass frit seal only.
 - E. Falls within MIL STD 1835 GDIP1-T14, GDIP1-T16, GDIP1-T18 and GDIP1-T20.

MECHANICAL DATA

MCFP002A – JANUARY 1995 – REVISED FEBRUARY 2002

W (R-GDFP-F14)

CERAMIC DUAL FLATPACK

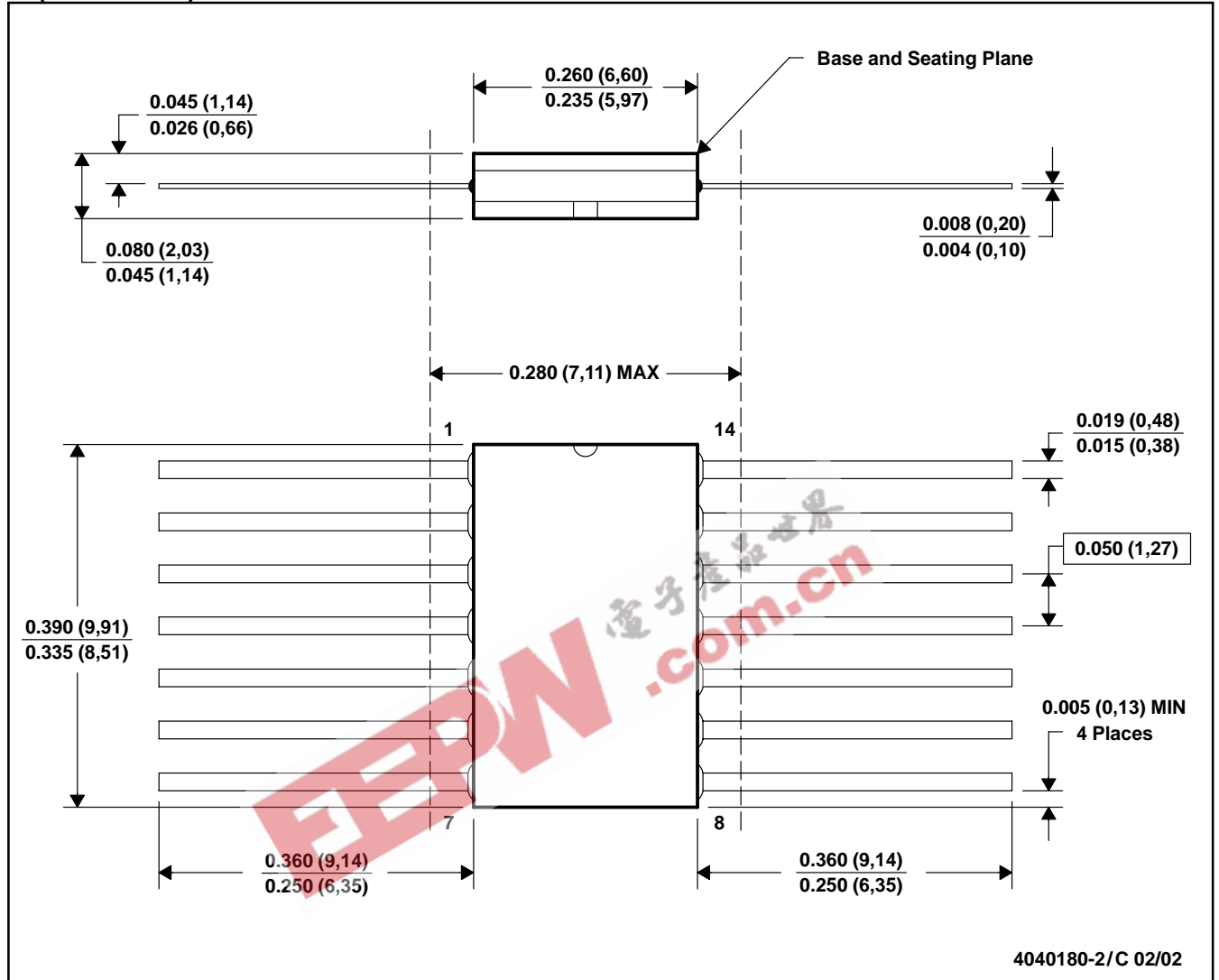

- NOTES: A. All linear dimensions are in inches (millimeters).
 B. This drawing is subject to change without notice.
 C. This package can be hermetically sealed with a ceramic lid using glass frit.
 D. Index point is provided on cap for terminal identification only.
 E. Falls within MIL STD 1835 GDFP1-F14 and JEDEC MO-092AB

MECHANICAL DATA

MLCC006B – OCTOBER 1996

FK (S-CQCC-N**)

LEADLESS CERAMIC CHIP CARRIER

28 TERMINAL SHOWN

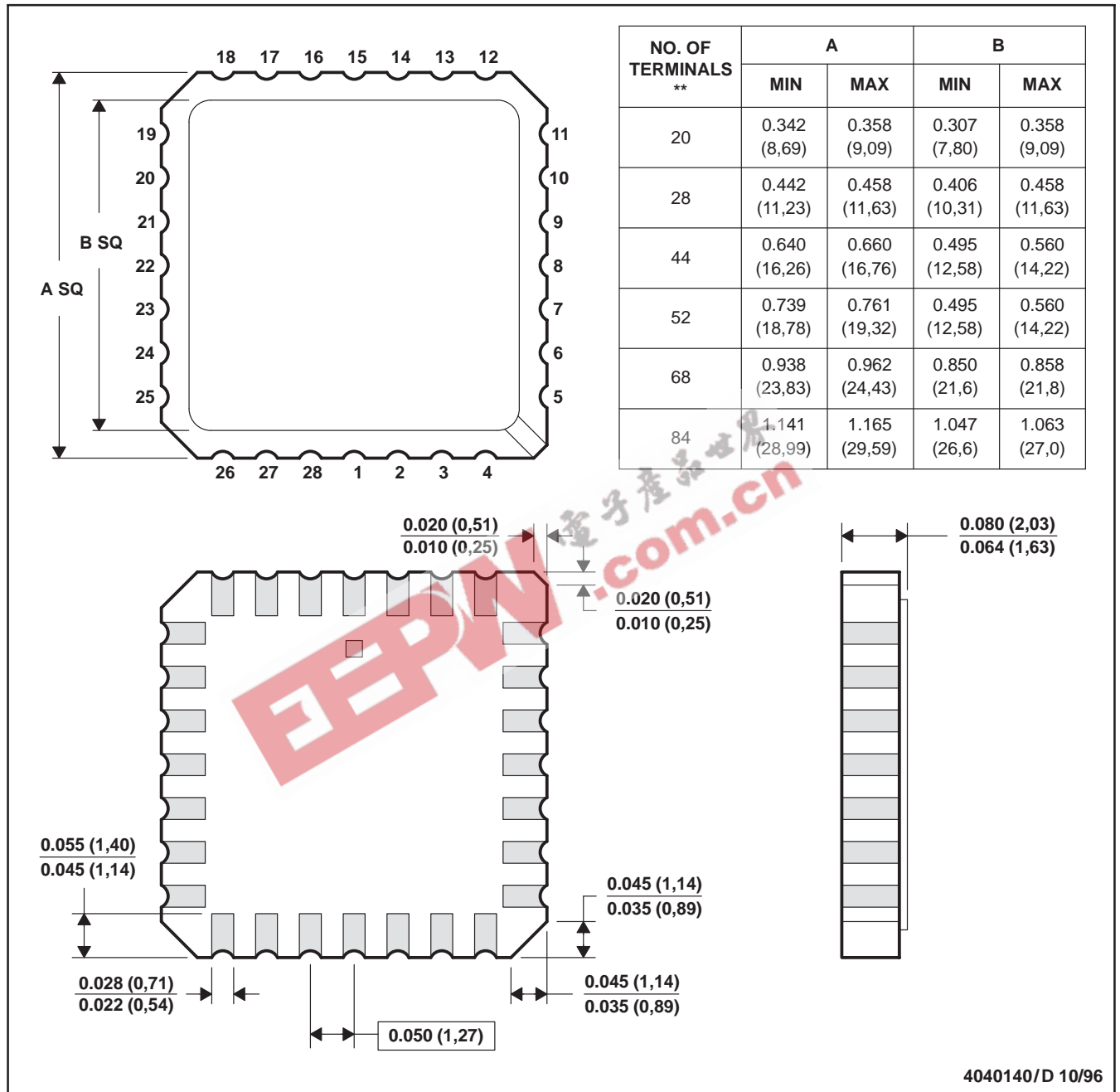

- NOTES:
- A. All linear dimensions are in inches (millimeters).
 - B. This drawing is subject to change without notice.
 - C. This package can be hermetically sealed with a metal lid.
 - D. The terminals are gold plated.
 - E. Falls within JEDEC MS-004

MECHANICAL DATA

N (R-PDIP-T**)

PLASTIC DUAL-IN-LINE PACKAGE

16 PINS SHOWN

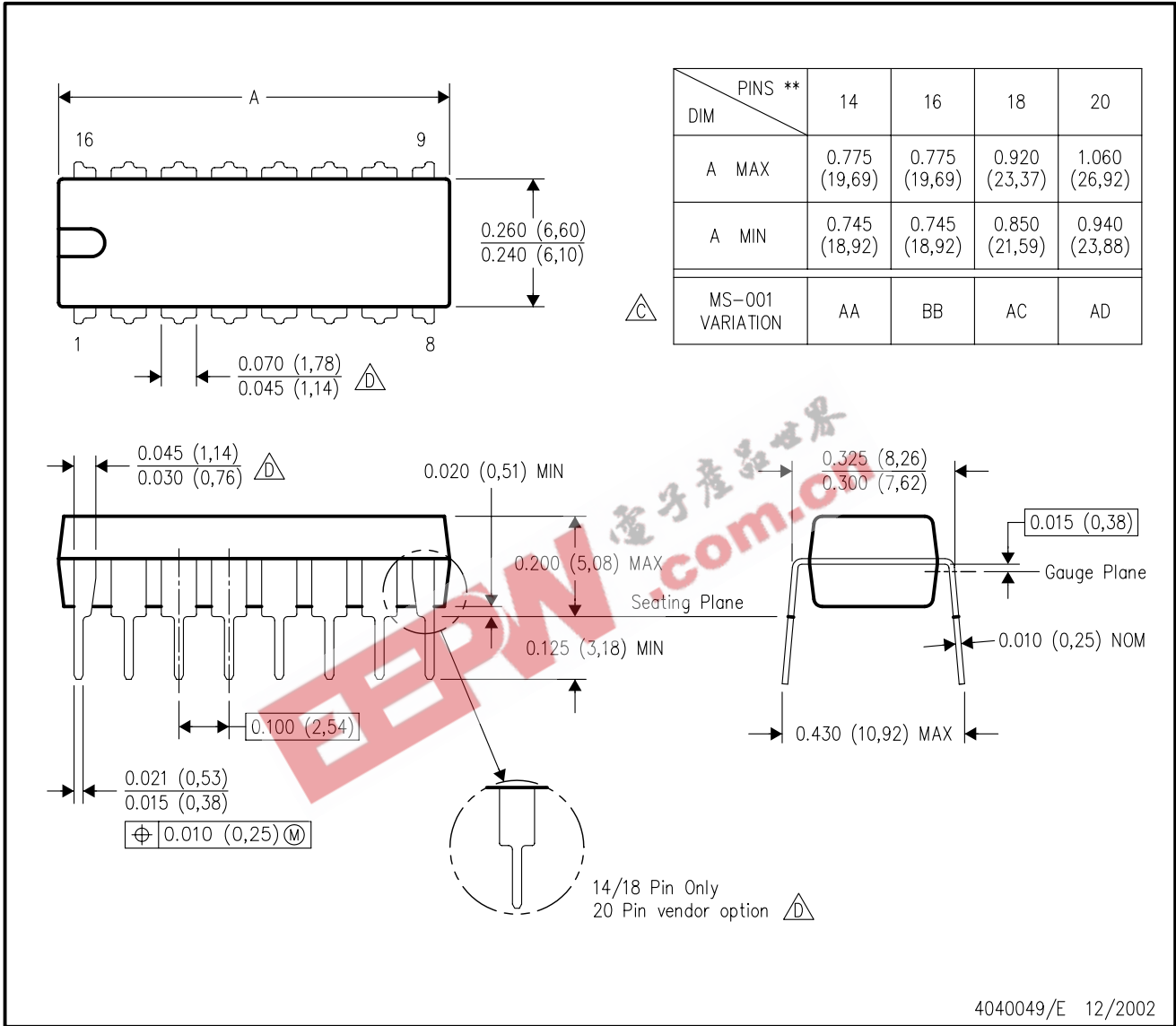

- NOTES:
- A. All linear dimensions are in inches (millimeters).
 - B. This drawing is subject to change without notice.
 - Falls within JEDEC MS-001, except 18 and 20 pin minimum body length (Dim A).
 - The 20 pin end lead shoulder width is a vendor option, either half or full width.

MECHANICAL DATA

D (R-PDSO-G14)

PLASTIC SMALL-OUTLINE PACKAGE

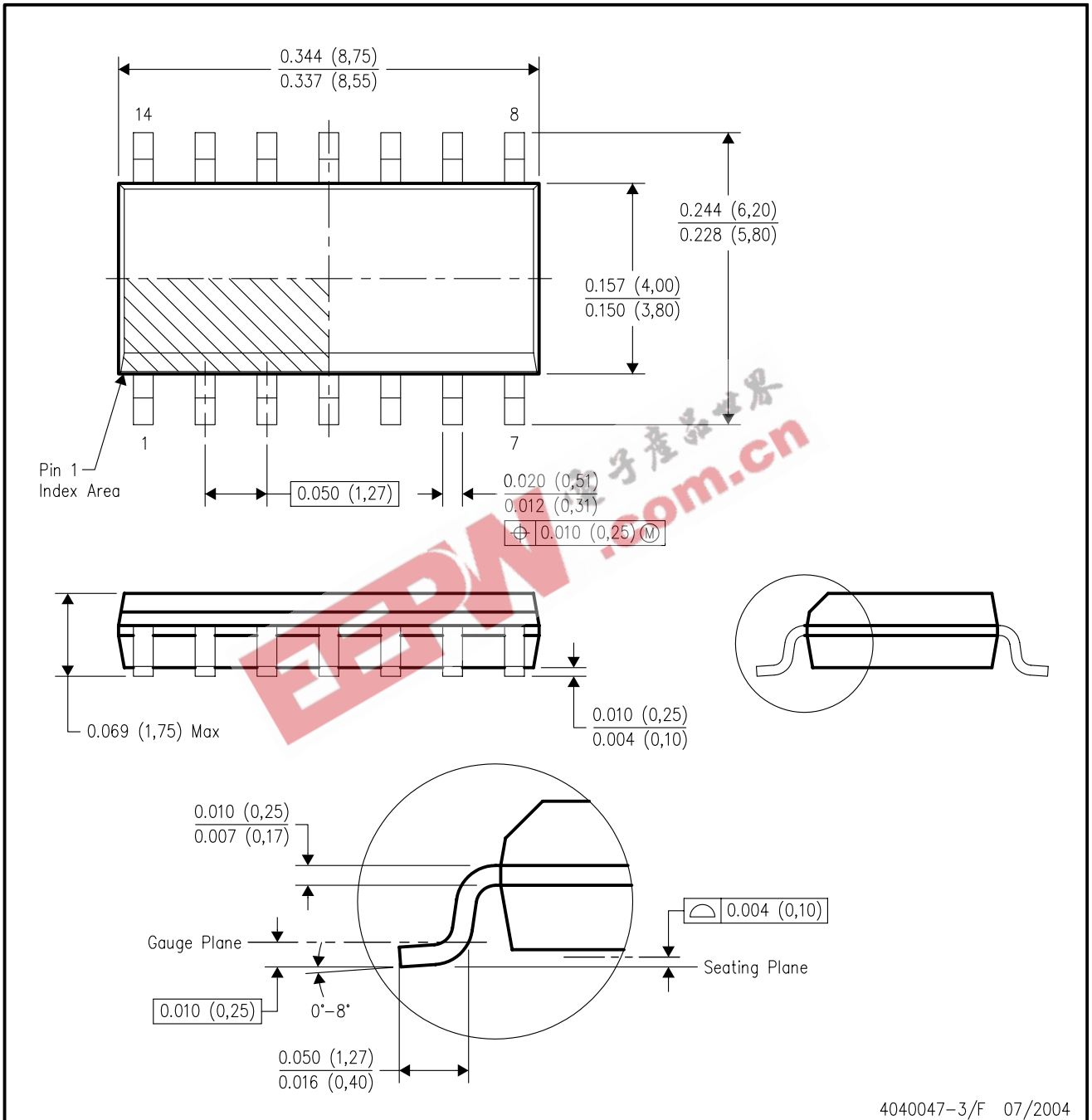

4040047-3/F 07/2004

- NOTES:
- All linear dimensions are in inches (millimeters).
 - This drawing is subject to change without notice.
 - Body dimensions do not include mold flash or protrusion not to exceed 0.006 (0,15).
 - Falls within JEDEC MS-012 variation AB.

MECHANICAL DATA

NS (R-PDSO-G)**

PLASTIC SMALL-OUTLINE PACKAGE

14-PINS SHOWN

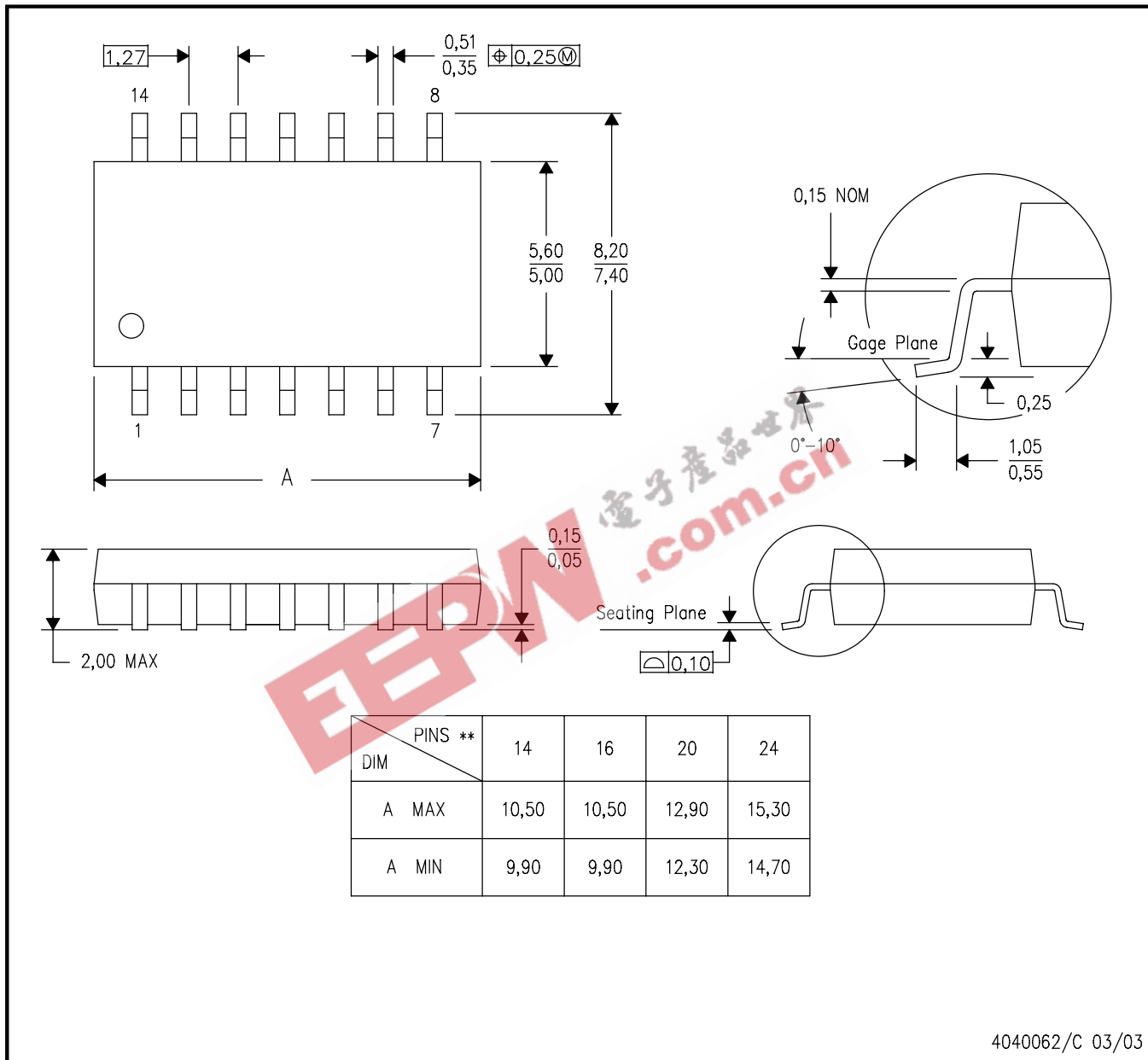

4040062/C 03/03

- NOTES:
- All linear dimensions are in millimeters.
 - This drawing is subject to change without notice.
 - Body dimensions do not include mold flash or protrusion, not to exceed 0,15.

MECHANICAL DATA

MSS0002E – JANUARY 1995 – REVISED DECEMBER 2001

DB (R-PDSO-G**)

PLASTIC SMALL-OUTLINE

28 PINS SHOWN

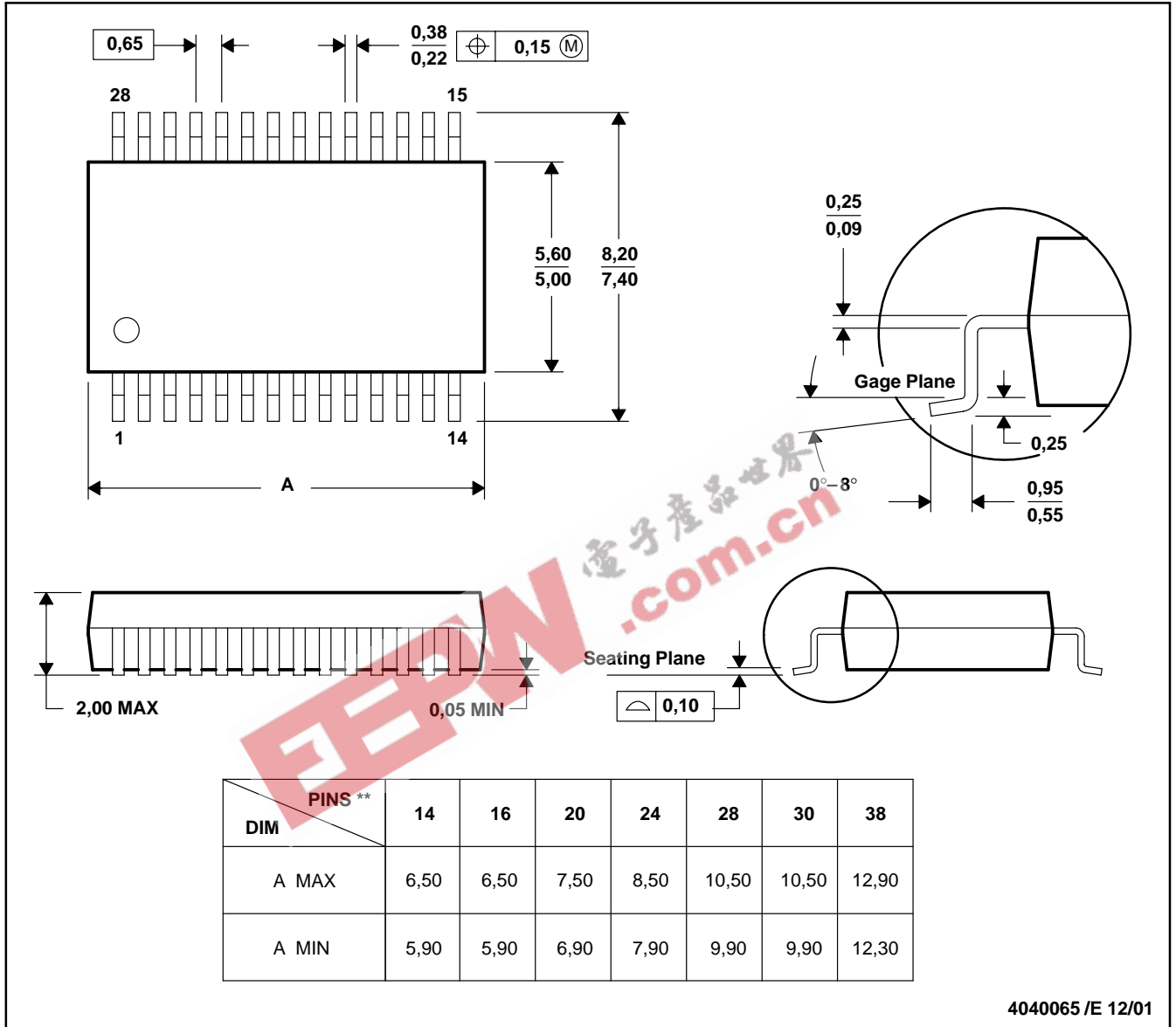

4040065 /E 12/01

- NOTES: A. All linear dimensions are in millimeters.
 B. This drawing is subject to change without notice.
 C. Body dimensions do not include mold flash or protrusion not to exceed 0,15.
 D. Falls within JEDEC MO-150

MECHANICAL DATA

MTSS001C – JANUARY 1995 – REVISED FEBRUARY 1999

PW (R-PDSO-G**)

PLASTIC SMALL-OUTLINE PACKAGE

14 PINS SHOWN

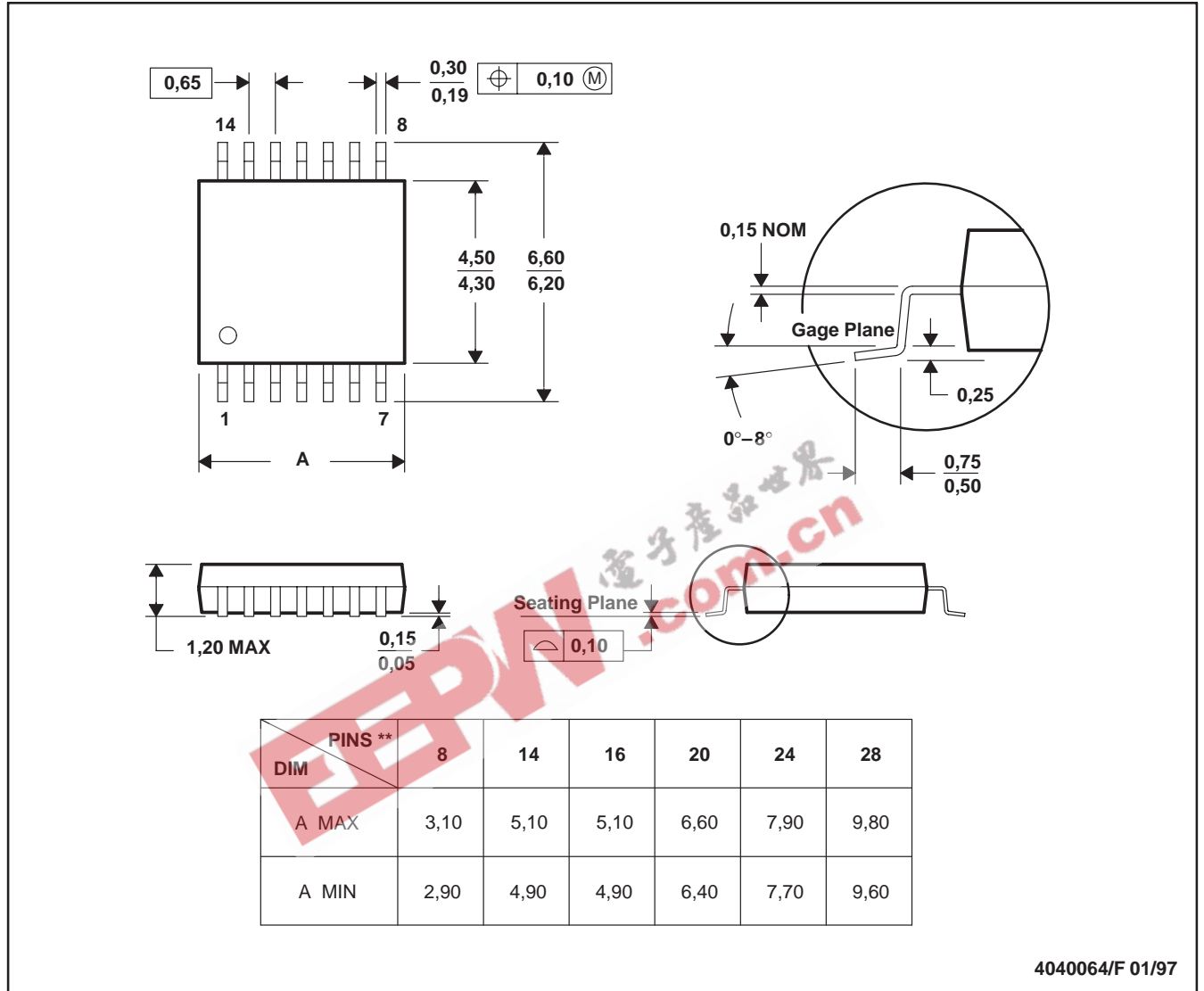

4040064/F 01/97

- NOTES: A. All linear dimensions are in millimeters.
 B. This drawing is subject to change without notice.
 C. Body dimensions do not include mold flash or protrusion not to exceed 0,15.
 D. Falls within JEDEC MO-153

IMPORTANT NOTICE

Texas Instruments Incorporated and its subsidiaries (TI) reserve the right to make corrections, modifications, enhancements, improvements, and other changes to its products and services at any time and to discontinue any product or service without notice. Customers should obtain the latest relevant information before placing orders and should verify that such information is current and complete. All products are sold subject to TI's terms and conditions of sale supplied at the time of order acknowledgment.

TI warrants performance of its hardware products to the specifications applicable at the time of sale in accordance with TI's standard warranty. Testing and other quality control techniques are used to the extent TI deems necessary to support this warranty. Except where mandated by government requirements, testing of all parameters of each product is not necessarily performed.

TI assumes no liability for applications assistance or customer product design. Customers are responsible for their products and applications using TI components. To minimize the risks associated with customer products and applications, customers should provide adequate design and operating safeguards.

TI does not warrant or represent that any license, either express or implied, is granted under any TI patent right, copyright, mask work right, or other TI intellectual property right relating to any combination, machine, or process in which TI products or services are used. Information published by TI regarding third-party products or services does not constitute a license from TI to use such products or services or a warranty or endorsement thereof. Use of such information may require a license from a third party under the patents or other intellectual property of the third party, or a license from TI under the patents or other intellectual property of TI.

Reproduction of information in TI data books or data sheets is permissible only if reproduction is without alteration and is accompanied by all associated warranties, conditions, limitations, and notices. Reproduction of this information with alteration is an unfair and deceptive business practice. TI is not responsible or liable for such altered documentation.

Resale of TI products or services with statements different from or beyond the parameters stated by TI for that product or service voids all express and any implied warranties for the associated TI product or service and is an unfair and deceptive business practice. TI is not responsible or liable for any such statements.

Following are URLs where you can obtain information on other Texas Instruments products and application solutions:

Products		Applications	
Amplifiers	amplifier.ti.com	Audio	www.ti.com/audio
Data Converters	dataconverter.ti.com	Automotive	www.ti.com/automotive
DSP	dsp.ti.com	Broadband	www.ti.com/broadband
Interface	interface.ti.com	Digital Control	www.ti.com/digitalcontrol
Logic	logic.ti.com	Military	www.ti.com/military
Power Mgmt	power.ti.com	Optical Networking	www.ti.com/opticalnetwork
Microcontrollers	microcontroller.ti.com	Security	www.ti.com/security
		Telephony	www.ti.com/telephony
		Video & Imaging	www.ti.com/video
		Wireless	www.ti.com/wireless

Mailing Address: Texas Instruments
Post Office Box 655303 Dallas, Texas 75265