

## LM2418 Triple 30 MHz CRT Driver

### General Description

The LM2418 contains three large signal voltage amplifiers designed to directly drive CRT cathodes for VGA Color Graphics Displays. Output swings greater than 50 V<sub>pp</sub> are achieved with a 90V power supply. The nominal voltage gain of each amplifier is -19 with gain matching of 1.0 dB between amplifiers.

Packaging is the industry standard molded 11 lead TO-220. The heatsink tab is isolated and may be grounded to improve RFI shielding and simplify assembly.

### Features

- 50 V<sub>pp</sub> output at 30 MHz drives CRT directly
- Rise/fall time typically 12 ns with 8 pF load
- 65V output swing capability
- Optimized output stage for low crossover distortion
- Gain matching of 1 dB
- Voltage gain of -19
- Includes oscillation suppression resistors

### Applications

- CRT driver for RGB monitors
- High voltage amplifiers

### Schematic and Connection Diagram

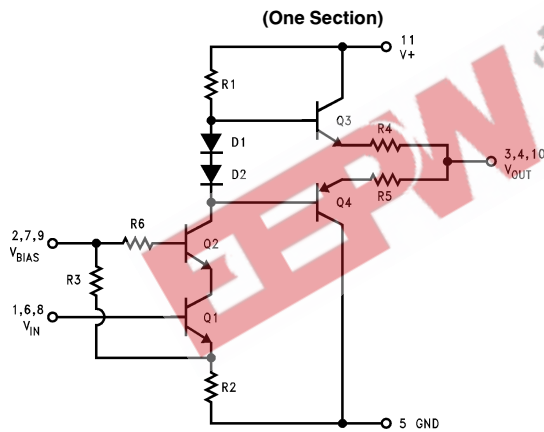
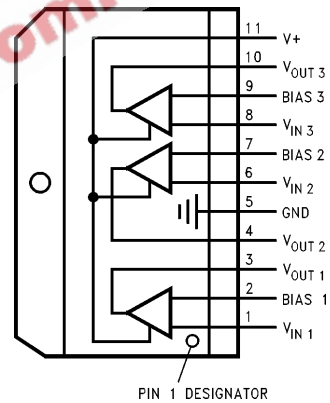

FIGURE 1



Top View

Order Number LM2418T  
See NS Package Number TA11B

## Absolute Maximum Ratings

If Military/Aerospace specified devices are required, please contact the National Semiconductor Sales Office/Distributors for availability and specifications.

Supply Voltage,  $V^+$  +95V  
Storage Temperature Range,  $T_{STG}$  -25°C to +100°C

Operating Temperature Range,  $T_{CASE}$  -20°C to +100°C  
Lead Temperature (Soldering, <10 sec.) 300°C  
ESD Tolerance tbd

## Electrical Characteristics

$V^+ = 90V$ ,  $C_L = 8\text{ pF}$ , DC input bias,  $V_{IN} = 3.6\text{ V}_{DC}$ . 50 V<sub>PP</sub> output swing,  $V_{BIAS} = +12V$ .  $T_A = 25^\circ\text{C}$  unless otherwise noted.

| Symbol       | Parameter                      | Conditions              | LM2418 |     |     | Units    |
|--------------|--------------------------------|-------------------------|--------|-----|-----|----------|
|              |                                |                         | Min    | Typ | Max |          |
| $I_{CC}$     | Supply Current (per Amplifier) | No Input or Output Load |        | 18  | 26  | mA       |
| $V_{OUT}$    | Output Offset Voltage          | $V_{IN} = 3.6V$         | 46     | 53  | 60  | $V_{DC}$ |
| $t_r$        | Rise Time                      | 10% to 90% (Note 3)     |        | 12  | 20  | ns       |
| $t_f$        | Fall Time                      | 10% to 90% (Note 3)     |        | 12  | 20  | ns       |
| BW           | Bandwidth                      | -3 dB                   |        | 30  |     | MHz      |
| $A_V$        | Voltage Gain                   |                         | -17    | -19 | -23 | V/V      |
| OS           | Overshoot                      |                         |        | 5   |     | %        |
| LE           | Linearity Error                | (Note 1)                |        | 8   |     | %        |
| $\Delta A_V$ | Gain Matching                  | (Note 2)                |        | 1.0 |     | dB       |

**Note 1:** Linearity Error is defined as the variation in small signal gain from +20V to +70V output with a 100 mV AC, 1 MHz, input signal.

**Note 2:** Calculated value from Voltage Gain test on each channel.

**Note 3:** Guaranteed parameter, not tested.

## AC Test Circuit

Figure 2 shows a typical test circuit for evaluation of the LM2418. This circuit is designed to allow testing of the LM2418 in a 50Ω environment such as a pulse generator, oscilloscope or network analyzer.

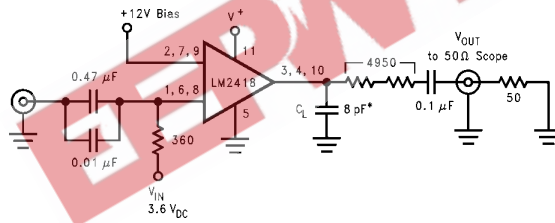

TL/K/11125-3

\*8 pF is total load capacitance. It includes all parasitic capacitance.

FIGURE 2. Test Circuit (One Section)

## Typical Performance Characteristics

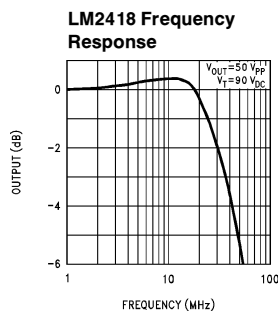

TL/K/11125-4

FIGURE 3

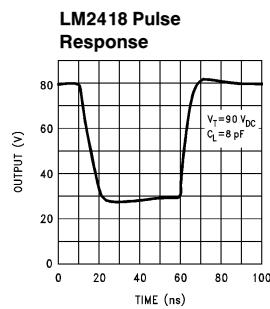

TL/K/11125-5

## LM2418—Theory of Operation

The LM2418 is a high voltage triple CRT driver suitable for VGA display applications. The LM2418 features 90V operation and low power dissipation. The part is housed in the industry standard 11-lead TO-220 molded power package. The heat sink is electrically isolated from the circuitry and may be grounded for ease of manufacturing and RFI shielding.

The circuit diagram of the LM2418 is shown in *Figure 1*. Q1 and R2 provide a conversion of input voltage to current, while Q2 acts as a common base or cascode amplifier stage to drive the load resistor R1. Emitter followers Q3 and Q4 isolate the impedance of R1 from the capacitance of the CRT cathode, and make the circuit relatively insensitive to load capacitance. The gain of this circuit is  $-R1/R2$  and is fixed at  $-19$ . The bandwidth of the circuit is set by the collector time constant formed by the load resistor R1 and associated capacitance of Q2, Q3, Q4, and stray layout capacitance. Diodes D1 and D2 provide forward bias to the output stage to reduce crossover distortion at low signal levels, while R3 provides a DC bias offset to match the output level characteristics of the LM1203 RGB Video Amplifier System. Proprietary transistor design allows for high bandwidth with low operating power.

*Figure 2* shows a typical test circuit for evaluation of the LM2418. This circuit is designed to allow testing of the LM2418 in a 50Ω environment such as a pulse generator and a scope, or a network analyzer. In this test circuit, two resistors in series totaling 4.95 kΩ form a wideband low

capacitance probe to match the output of the LM2418 to a 50Ω cable and load. Typical AC performance of the circuit is shown in *Figure 3*. The input signal is AC coupled to the base of Q1, while a DC bias of 12V is applied to the base of Q2 (See *Figure 2*).

## Thermal Considerations

The transfer characteristics of the amplifier are shown in *Figures 4* and *5*. Power supply current increases as the input signal increases and consequently power dissipation also increases.

The LM2418 cannot be used without heat sinking. *Figure 5* shows the power dissipated in each channel over the operating voltage range of the device. Typical "average" power dissipation with the device output voltage at one half the supply voltage is 1.8W per channel for a total dissipation of 5.4W package dissipation. Under white screen conditions, i.e., 20V output, dissipation increases to 3.0W per channel or 9W total. The LM2418 case temperature must be maintained below 100°C. If the maximum expected ambient temperature is 60°C, then a maximum heat sink thermal resistance can be calculated:

$$R_{th} = \frac{(100^{\circ}\text{C} - 60^{\circ}\text{C})}{9\text{W}} = 4.4^{\circ}\text{C}/\text{W}$$

**PRECAUTION: THE LM2418 IS NOT PROTECTED AGAINST OUTPUT SHORT CIRCUITS.** The minimum resistance the LM2418 can drive is 800Ω to ground or  $V^+$ .

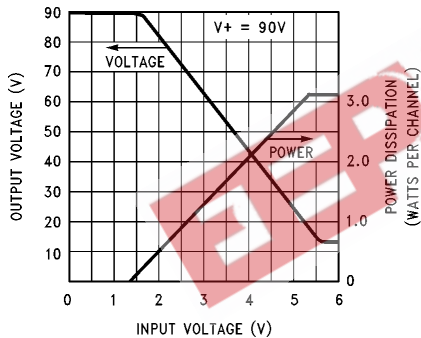

FIGURE 4. LM2418 DC Characteristics

TL/K/11125-7

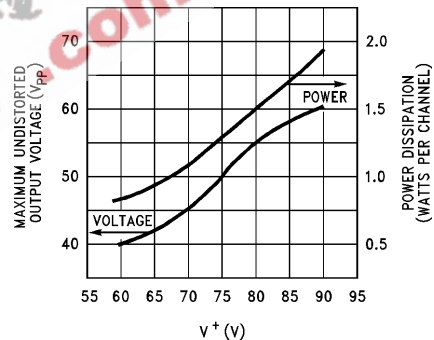

FIGURE 5. LM2418 Output Swing and Power Characteristics

TL/K/11125-9

## Typical Application

A typical application of the LM2418 is shown in Figure 6. Used in conjunction with an LM1203, a complete video channel from monitor input to CRT cathode is shown. Performance is satisfactory for all applications up to 640 by 480 lines. Typical rise/fall times of this circuit are 15 ns, with

better than 50 V<sub>pp</sub> drive signals available to a 10 pF load. In this application, feedback is local to the LM1203, an alternative scheme would feed back from the output of the LM2418 to the positive clamp inputs of the LM1203. This would provide better black level control of the system.

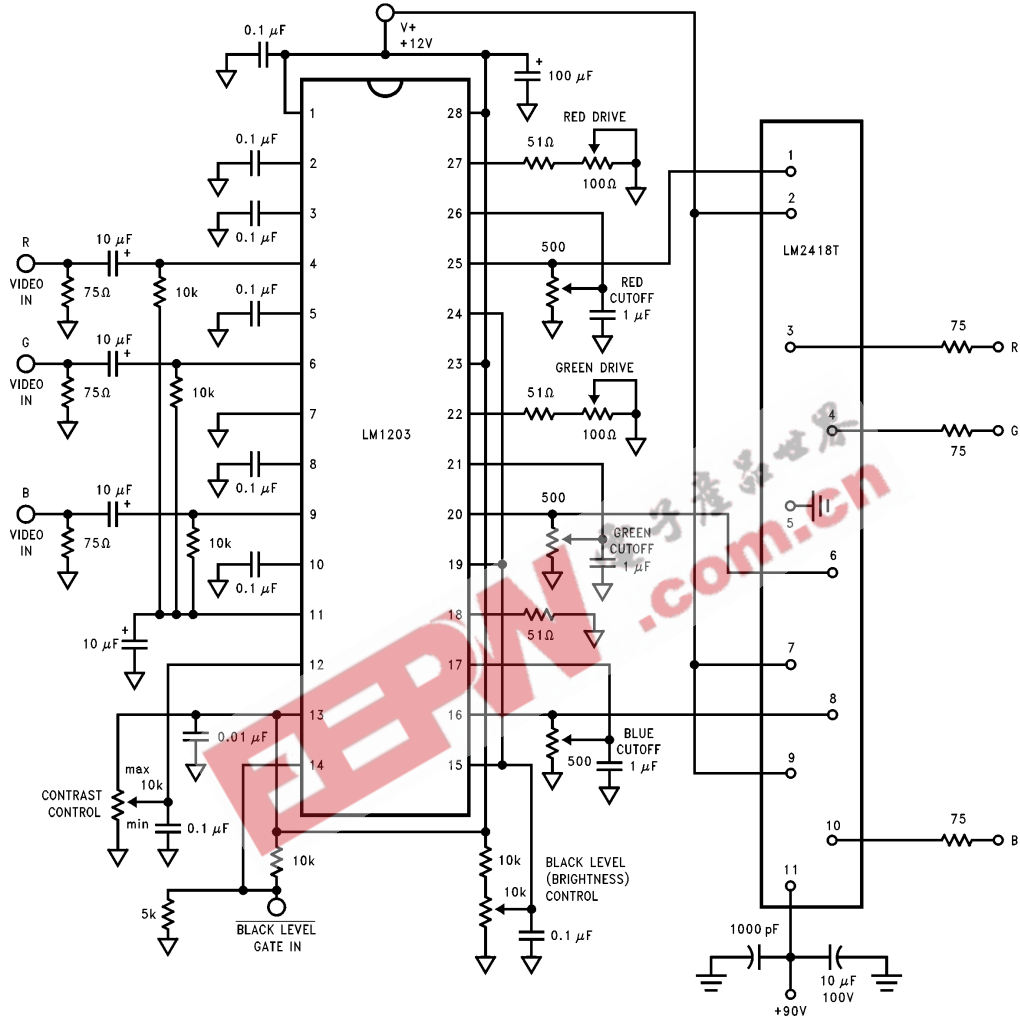
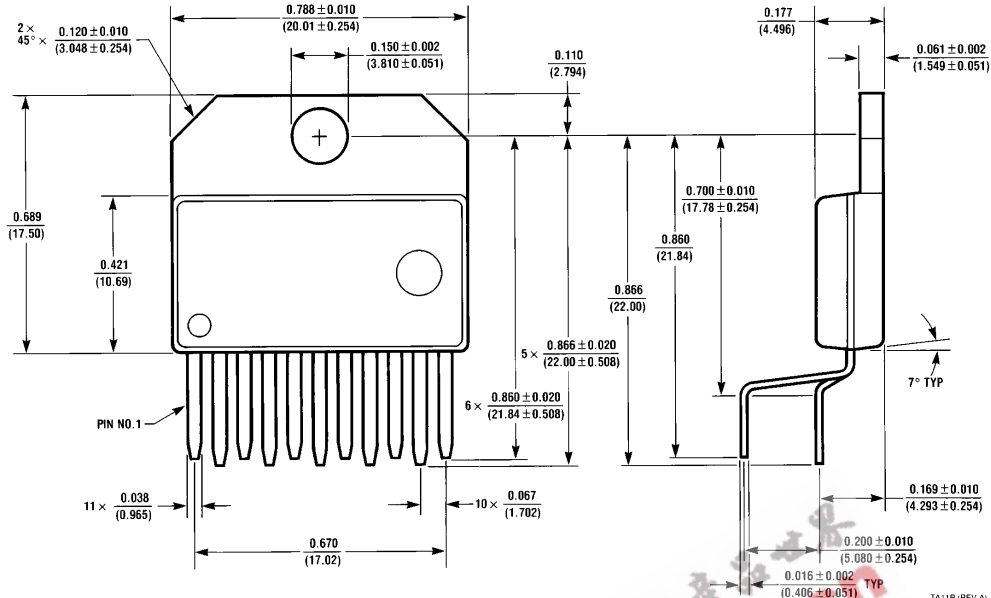

FIGURE 6. Typical Application LM1203-LM2418 Application

TL/K/11125-10

EEPW 电子产品世界  
.com.cn

**Physical Dimensions** inches (millimeters)



**11 Lead TO-220 Molded Package (T)**  
**Order Number LM2418T**  
**NS Package Number TA11B**

**LIFE SUPPORT POLICY**

NATIONAL'S PRODUCTS ARE NOT AUTHORIZED FOR USE AS CRITICAL COMPONENTS IN LIFE SUPPORT DEVICES OR SYSTEMS WITHOUT THE EXPRESS WRITTEN APPROVAL OF THE PRESIDENT OF NATIONAL SEMICONDUCTOR CORPORATION. As used herein:

1. Life support devices or systems are devices or systems which, (a) are intended for surgical implant into the body, or (b) support or sustain life, and whose failure to perform, when properly used in accordance with instructions for use provided in the labeling, can be reasonably expected to result in a significant injury to the user.
2. A critical component is any component of a life support device or system whose failure to perform can be reasonably expected to cause the failure of the life support device or system, or to affect its safety or effectiveness.



**National Semiconductor Corporation**  
 1111 West Bardin Road  
 Arlington, TX 76017  
 Tel: 1(800) 272-9959  
 Fax: 1(800) 737-7018

**National Semiconductor Europe**  
 Fax: (+49) 0-180-530 85 86  
 Email: cnjwge@levm2.nsc.com  
 Deutsch Tel: (+49) 0-180-530 85 85  
 English Tel: (+49) 0-180-532 78 32  
 Français Tel: (+49) 0-180-532 93 58  
 Italiano Tel: (+49) 0-180-534 16 80

**National Semiconductor Hong Kong Ltd.**  
 13th Floor, Straight Block,  
 Ocean Centre, 5 Canton Rd.  
 Tsimshatsui, Kowloon  
 Hong Kong  
 Tel: (852) 2737-1600  
 Fax: (852) 2736-9960

**National Semiconductor Japan Ltd.**  
 Tel: 81-043-299-2309  
 Fax: 81-043-299-2408