

DUAL 250mW AUDIO POWER AMPLIFIER WITH SHUTDOWN MODE

DESCRIPTION

The UTC LM4880 is a dual audio power amplifier capable of delivering typically 250mW per channel of continuous average power to an 8 Ω load with 0.1% THD+N using a 5V power supply.

The UTC LM4880 features an externally controlled, low-power consumption shutdown mode, as well as an internal thermal shutdown protection mechanism.

The unity-gain stable UTC LM4880 can be configured by external gain-setting resistors.

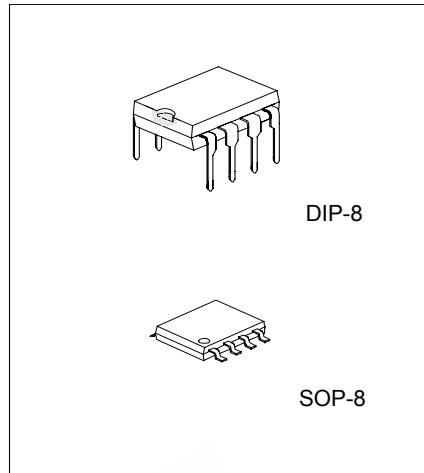

DIP-8

SOP-8

*Pb-free plating product number: LM4880L

FEATURES

- *No bootstrap capacitors or snubber circuits are necessary
- *Unity-gain stable
- *External gain configuration capability

APPLICATIONS

- *Personal Computers
- *CD-ROM Players
- *Headphone Amplifier

PIN CONFIGURATION

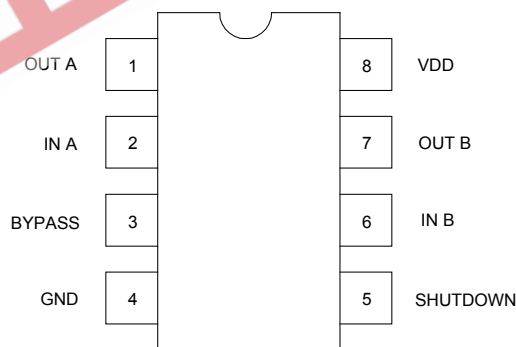

ABSOLUTE MAXIMUM RATINGS (Note 2)

PARAMETER	SYMBOL	RATINGS	UNIT
Supply Voltage	V _{DD}	6.0	V
Input Voltage	V _i	-0.3 ~ V _{DD} +0.3	V
ESD Susceptibility (Note 3)	ESD	3500	V
ESD Susceptibility (Note 4)		250	V
Power Dissipation (Note 5)	P _d	Internally limited	
Operating Temperature	T _{opr}	-40 ~ +85	°C
Storage Temperature	T _{stg}	-65 ~ +150	°C
Junction Temperature	T _j	150	°C

THERMAL CHARACTERISTICS

PARAMETER	SYMBOL	RATINGS	UNIT	
Thermal resistance from junction to Case	θ _{JC}	DIP-8	37	°C/W
		SOP-8	35	
Thermal resistance from junction to Ambient	θ _{JA}	DIP-8	107	°C/W
		SOP-8	170	

OPERATING RATINGS

PARAMETER	SYMBOL	RATINGS	UNIT
Supply Voltage	V _{DD}	2.7 ~ 5.5	V
Temperature Range (T _{MIN} T _a T _{MAX})	T _a	-40 ~ +85	

ELECTRICAL CHARACTERISTICS (Note 1,2)

(T_a=25°C, The following specifications apply for V_{DD}=5V, f=1kHz unless otherwise specified)

PARAMETER	SYMBOL	TEST CONDITIONS	MIN	TYP	MAX	UNIT
Supply Voltage	V _{DD}		2.7		5.5	V
Quiescent Power Supply Current	I _{DD}	V _{IN} =0V, I _o =0A		3.6	6.0	mA
Shutdown Current	I _{SD}	V _{PIN5} =V _{DD}		0.7	5	μA
Output Offset Voltage	V _{OS}	V _{IN} =0V		5	50	mV
Output Power	P _o	THD=0.1%(max) R _L =8Ω	200	250		mW
		R _L =32Ω THD+N=10%		85		mW
Total Harmonic Distortion + Noise	THD+N	R _L =8Ω, P _o =200mW		0.03		%
		R _L =32Ω, P _o =75mW		0.02		%
Power Supply Rejection Ratio	PSRR	C _B =1.0 μF V _{RIPPLE} =200mVrms, f=100Hz		50		dB

Note 1: All voltages are measured with respect to the ground pin, unless otherwise specified.

Note 2: Absolute Maximum Ratings indicate limits beyond which damage may occur. Operating Ratings indicate conditions for which the device is functional, but do not guarantee specific performance limits. Electrical Characteristics state DC and AC electrical specifications under particular test conditions which guarantee specific performance limits. This assumes that the device is within the Operating Ratings. Specifications are not guaranteed for parameters where no limit is given, however, the typical value is a good indication of

device performance.

Note 3: Human body model, 100 pF discharged through a 1.5 k resistor.

Note 4: Machine model, 220 pF ~ 240 pF discharged through all pins.

Note 5: The maximum power dissipation must be derated at elevated temperatures and is dictated by T_{JMAX} , J_A , and the ambient temperature T_A . The maximum allowable power dissipation is $P_{DMAX} = (T_{JMAX} - T_A) / J_A$ or the number given in the Absolute Maximum Ratings, whichever is lower. For the UTC LM4880, $T_{JMAX} = 150^\circ C$, and the typical junction-to-ambient thermal resistance is $170^\circ C/W$ for SOP-8 package and $107^\circ C/W$ for DIP-8 package.

TYPICAL APPLICATION

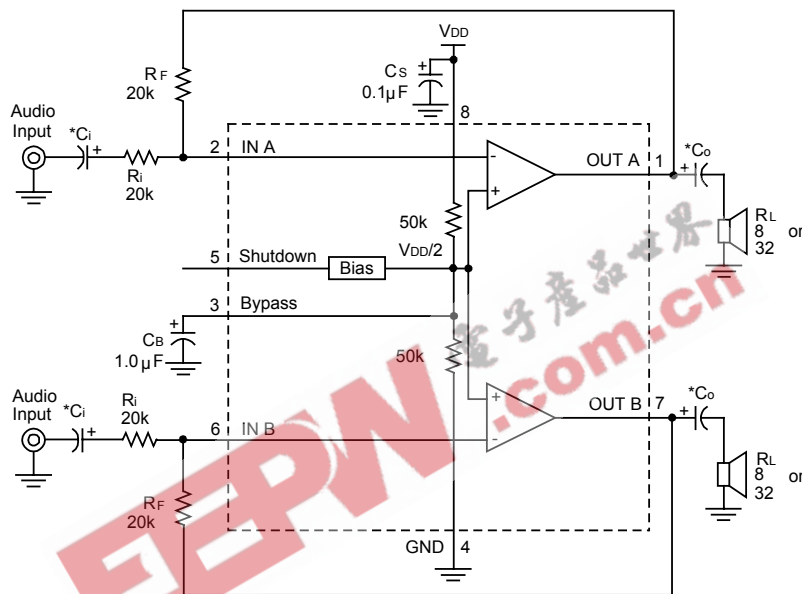

Figure 1. Typical Audio Amplifier Application Circuit

EXTERNAL COMPONENTS DESCRIPTION (Figure 1)

COMPONENTS	FUNCTIONAL DESCRIPTION
1. Ri	Inverting input resistance which sets the closed-loop gain in conjunction with Rf. This resistor also forms a high pass filter with Ci at $f_c = 1/(2\pi R_i C_i)$.
2. Ci	Input coupling capacitor which blocks the DC voltage at the amplifier's input terminals. Also creates a high pass filter with Ri at $f_c = 1/(2\pi R_i C_i)$.
3. Rf	Feedback resistance which sets closed-loop gain in conjunction with Ri.
4. Cs	Supply bypass capacitor which provides power supply filtering.
5. Cb	Bypass pin capacitor which provides half-supply filtering.
6. Co	Output coupling capacitor which blocks the DC voltage at the amplifier's output. Forms a high pass filter with RL at $f_o = 1/(2\pi R_L C_o)$.

AUTOMATIC SHUTDOWN CIRCUIT

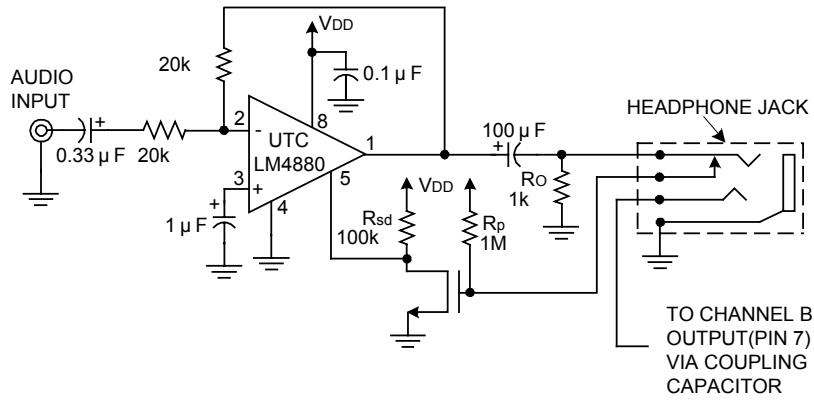

Figure 2. Automatic Shutdown Circuit

AUTOMATIC SWITCHING CIRCUIT

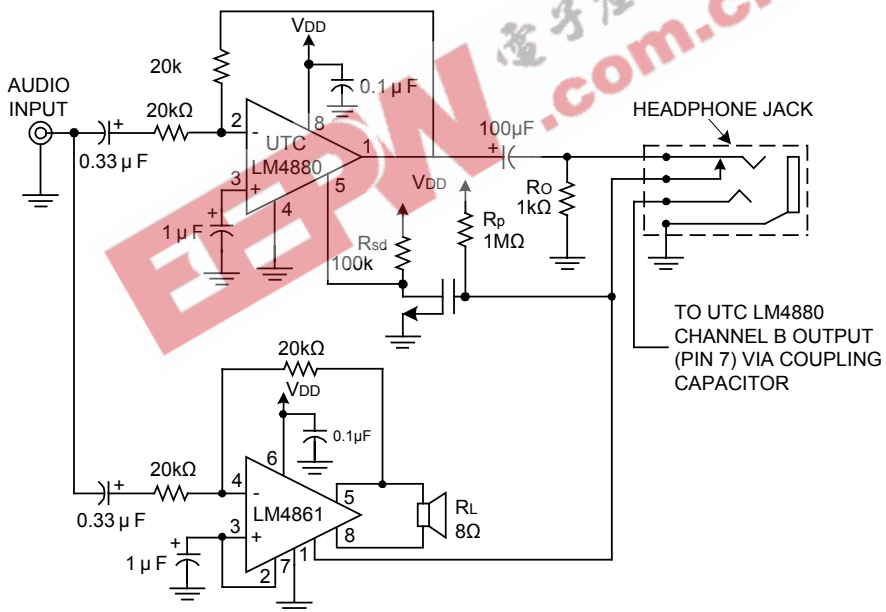
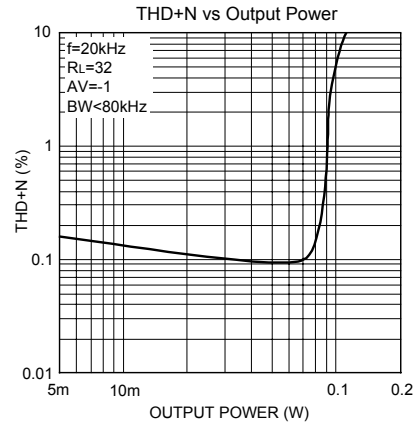
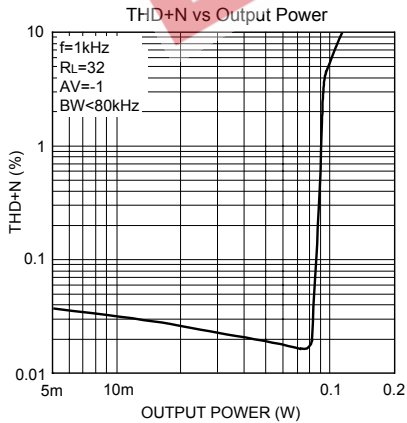
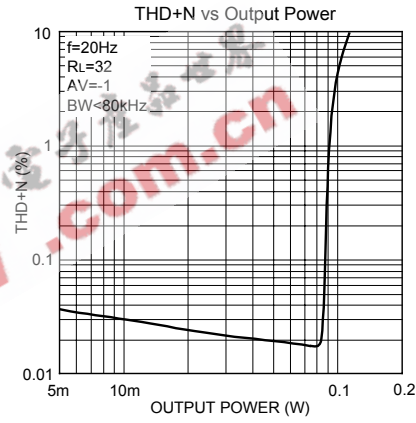
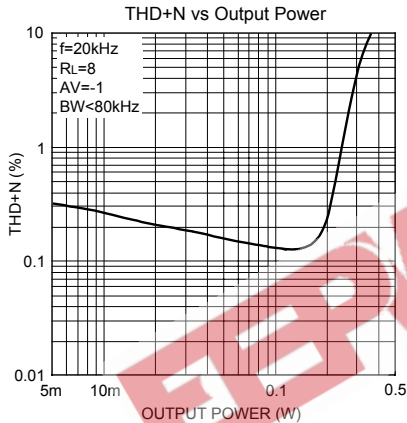
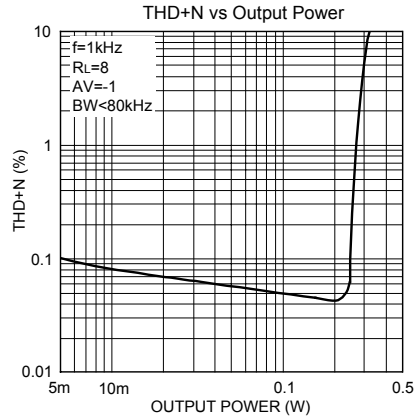
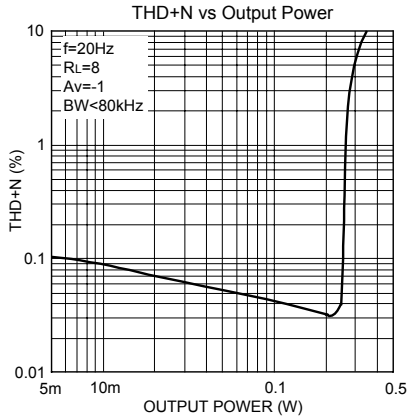
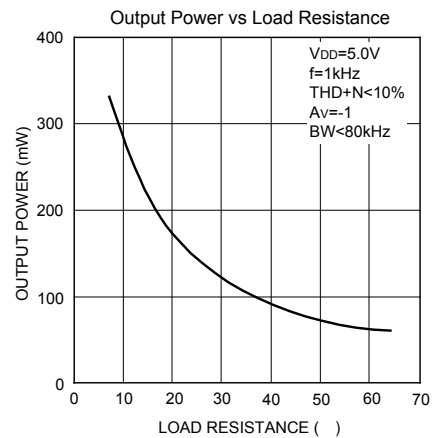
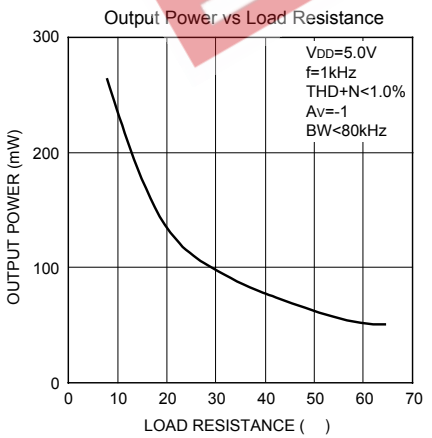
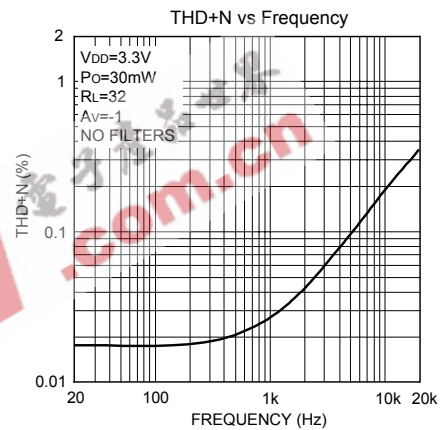
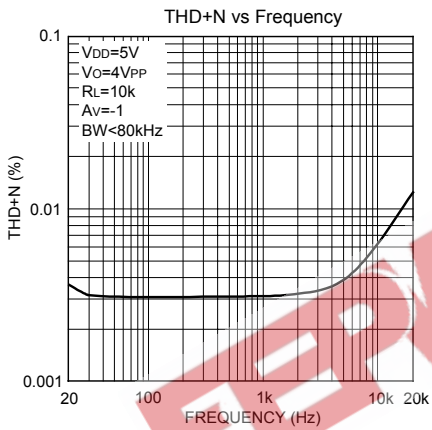
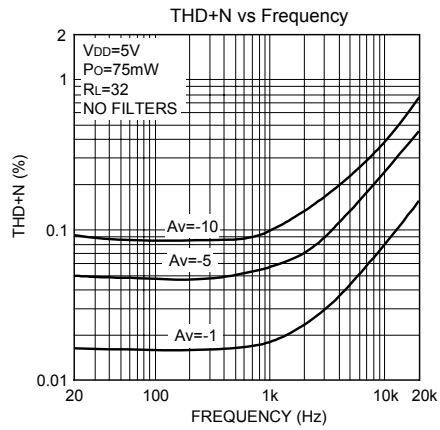
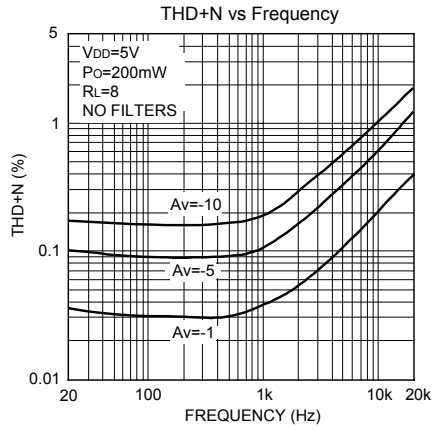
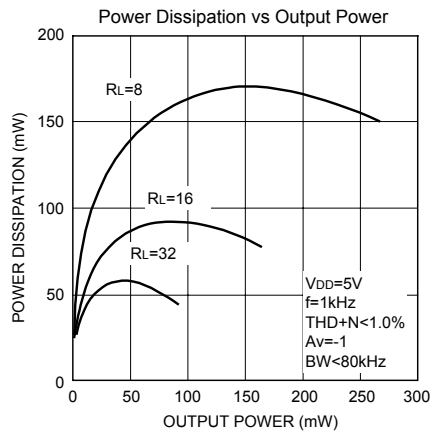
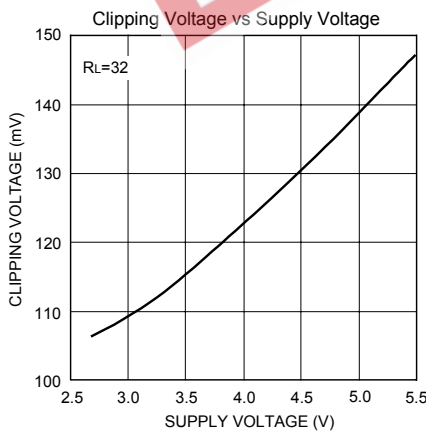
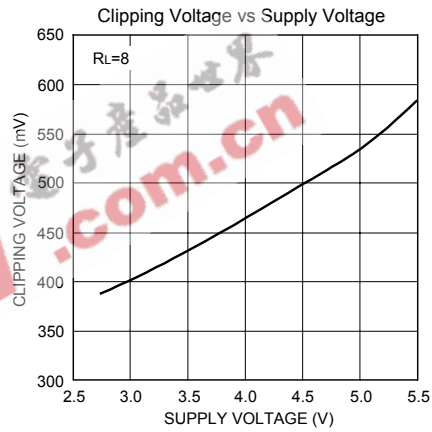
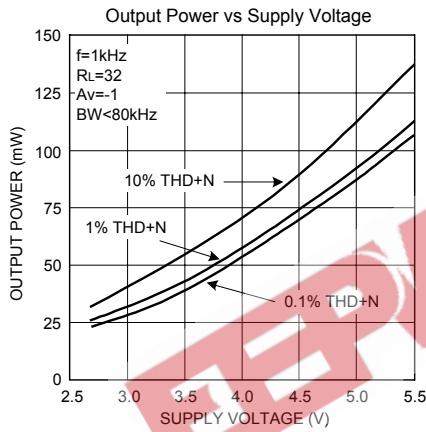
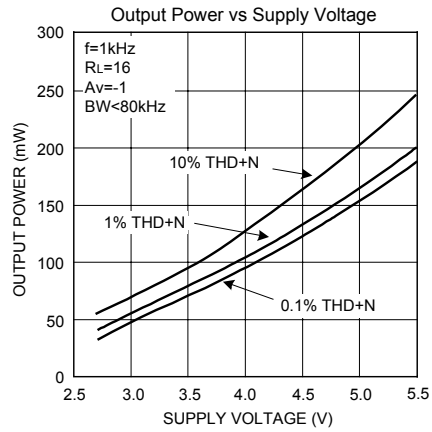
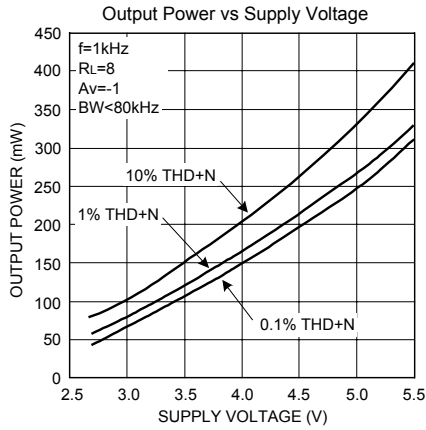

Figure 3. Automatic Switching Circuit

TYPICAL PERFORMANCE CHARACTERISTICS







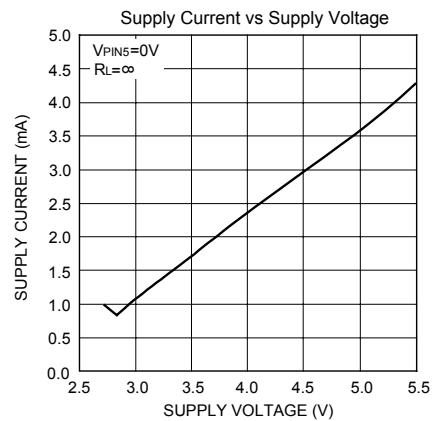
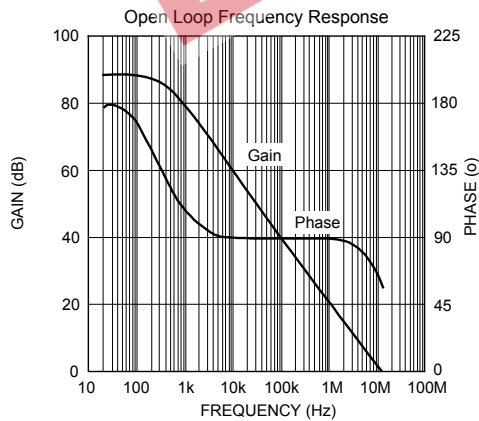
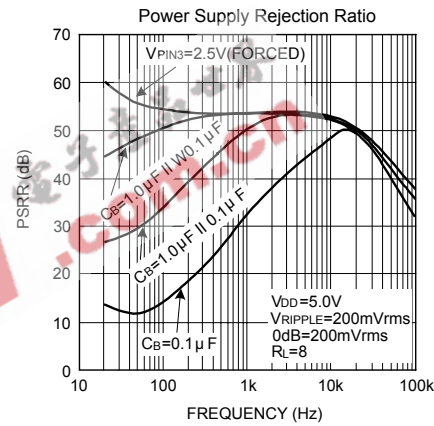
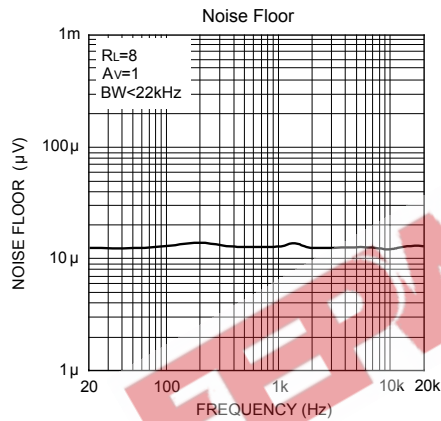
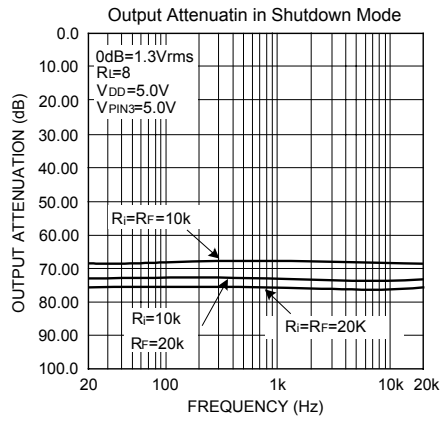
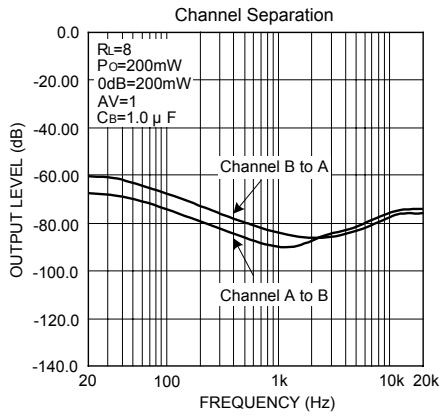

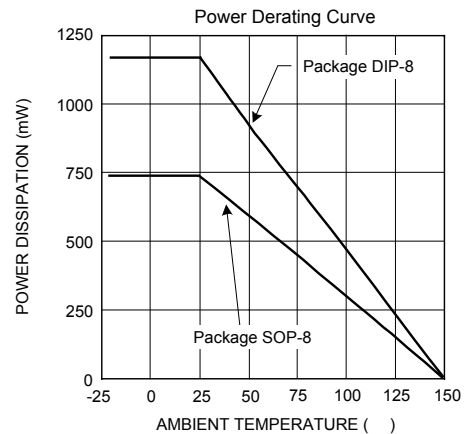
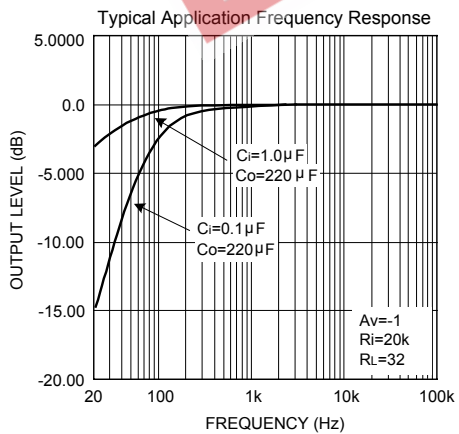
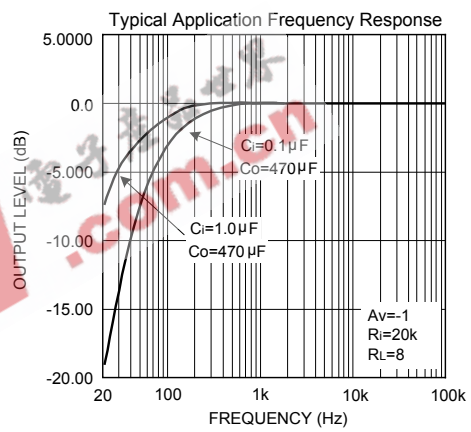
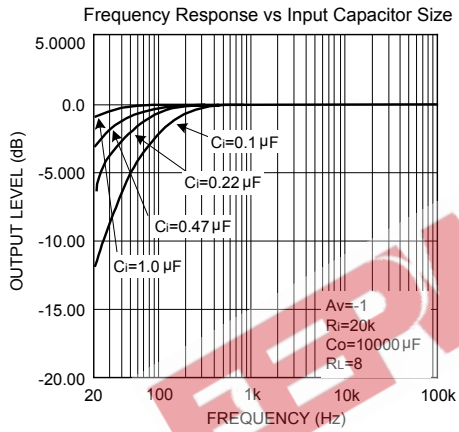
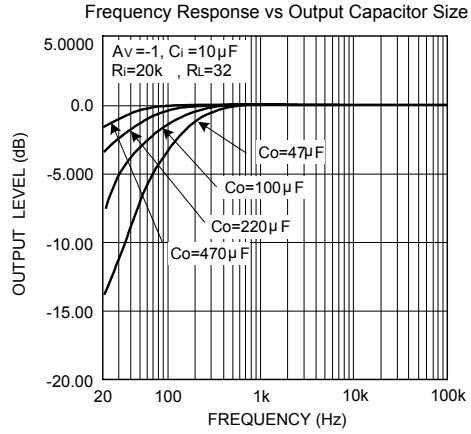
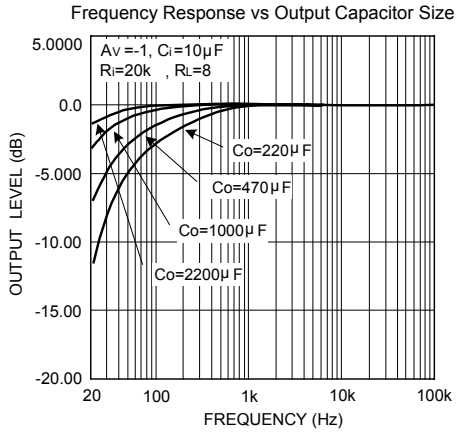

EEPW 电子产品世界
.com.cn

UTC assumes no responsibility for equipment failures that result from using products at values that exceed, even momentarily, rated values (such as maximum ratings, operating condition ranges, or other parameters) listed in products specifications of any and all UTC products described or contained herein. UTC products are not designed for use in life support appliances, devices or systems where malfunction of these products can be reasonably expected to result in personal injury. Reproduction in whole or in part is prohibited without the prior written consent of the copyright owner. The information presented in this document does not form part of any quotation or contract, is believed to be accurate and reliable and may be changed without notice.