

LM2567 LAN DC/DC Converter

General Description

The LM2567 DC/DC converter is intended for use in LAN applications as a power supply for the DP8392 Coaxial Transceiver. The converter may be operated from an input voltage of 5V ($\pm 10\%$) to 15V. It provides an isolated output of $-9V$ for loads of up to 180 mA, with an efficiency of 78% (typical). The few external components required for the converter are completely specified within this datasheet.

Protection features for the LM2567-based DC/DC converter include thermal and current limit. Undervoltage lockout and soft-start are incorporated to minimize the inrush current during start-up.

Features

- Wide input voltage range, 5V to 15V
- Tight line regulation, 0.5% (typ)
- Output voltage tolerance $\pm 5\%$
- Few external components required
- Surface-mount packaging
- Fixed switching frequency of 52 kHz
- Current-mode operation for improved transient response

Typical Applications

- Power supply for DP8392 (LAN) coaxial transceiver: Isolated $-9V$ output for up to 180 mA load

Typical Application

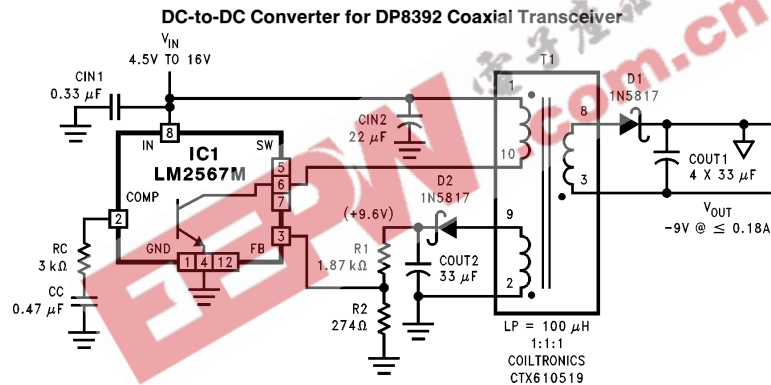

TL/H/11731-1

Connection Diagram and Ordering Information

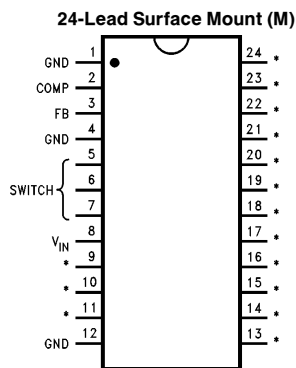

TL/H/11731-2
*No internal connection

Top View

Order Number LM2567M
See NS Package Number M24B

Absolute Maximum Ratings (Note 1)

If Military/Aerospace specified devices are required, please contact the National Semiconductor Sales Office/Distributors for availability and specifications.

Supply Voltage	40V
Output Switch Voltage	50V
Output Switch Current	6.0A
Power Dissipation	Internally Limited
Storage Temperature Range	-65°C to +150°C
Lead Temperature (Soldering, 10 sec.)	260°C
Maximum Junction Temperature	150°C
Minimum ESD Rating (C = 100 pF, R = 1.5 kΩ)	2 kV

Operating Ratings

Supply Voltage	$3.5V \leq V_{IN} \leq 35V$
Output Switch Voltage	$0V \leq V_{SW} \leq 45V$
Output Switch Current	$I_{SW} \leq 3.0A$
Junction Temperature Range	$0^\circ C \leq T_J \leq +125^\circ C$
Ambient Temperature Range	$0^\circ C \leq T_A \leq +70^\circ C$

Electrical Characteristics

Specifications with standard type face are for $T_J = 25^\circ C$, and those in **bold typeface** apply over full **Operating Temperature Range**. Unless otherwise specified, $V_{IN} = 5V$, $V_{FB} = V_{REF}$, and $I_{SWITCH} = 0$. (Note 2)

Symbol	Parameter	Conditions	Typ	Min	Max	Units
GENERAL DEVICE PARAMETERS						
I_S	Input Supply Current	$V_{FB} = 1.5V$ (Switch Off)	7.5		10.0	mA
					14.0	mA
		$I_{SW} = 2.0A$ $V_{COMP} = 2.0V$ (Max. Duty Cycle)	20		50	mA
					85	mA
V_{UV}	Input Supply Undervoltage Lockout	$I_{SW} = 100 mA$ $V_{COMP} = 1.2V$	2.90	2.60	3.10	V
				2.55	3.15	V
f_O	Oscillator Frequency	Measured at Switch Pin	52	48	56	kHz
		$I_{SW} = 100 mA$		42	62	kHz
V_{REF}	Reference Voltage	Measured at Feedback Pin	1.230	1.214	1.246	V
		$V_{IN} = 3.5V$ to $35V$ $V_{COMP} = 1.0V$		1.206	1.254	V
$\frac{\Delta V_{REF}}{\Delta V_{IN}}$	Reference Voltage Line Regulation	$V_{IN} = 3.5V$ to $35V$	0.5			mV
θ_{JA}	Thermal Resistance	Junction-to-Ambient (Note 3)	100			$^\circ C/W$
ERROR AMPLIFIER PARAMETERS						
I_B	Error Amp Input Bias Current	$V_{COMP} = 1.0V$	100		300	nA
					800	nA
G_M	Error Amp Transconductance	$I_{COMP} = -30 \mu A$ to $+30 \mu A$ $V_{COMP} = 1.0V$	3700	2400	4800	μmho
				1600	5800	μmho
A_V	Error Amp Voltage Gain	$V_{COMP} = 1.1V$ to $1.6V$ $R_{COMP} = 1.0 M\Omega$ (Note 4)	800	500		V/V
				250		V/V
	Error Amp Output Swing	Upper Limit $V_{FB} = 1.0V$	2.4	2.2		V
				2.0		V
	Error Amp Output Swing	Lower Limit $V_{FB} = 1.5V$	0.3		0.40	V
					0.55	V
	Error Amp Output Current	$V_{FB} = 1.0V$ to $1.5V$ $V_{COMP} = 1.0V$	± 200	± 130 ± 90	± 300 ± 400	μA μA
I_{SS}	Soft Start Current	$V_{FB} = 1.0V$ $V_{COMP} = 0V$	5.0	2.5	7.5	μA μA
				1.5	9.5	
D	Maximum Duty Cycle	$V_{COMP} = 1.2V$ $I_{SW} = 100 mA$	95	93		%
				88		%

Electrical Characteristics (Continued)

Specifications with standard type face are for $T_J = 25^\circ\text{C}$, and those in **bold typeface** apply over full **Operating Temperature Range**. Unless otherwise specified, $V_{IN} = 5\text{V}$, $V_{FB} = V_{REF}$, and $I_{SWITCH} = 0$. (Note 2)

Symbol	Parameter	Conditions	Typ	Min	Max	Units
SWITCH PARAMETERS						
$\Delta I_{SWITCH}/\Delta V_{COMP}$	Switch Transconductance		12.5			A/V
I_L	Switch Leakage Current	Switch Off ($V_{FB} = 1.5\text{V}$) $V_{SW} = 50\text{V}$	10		300 600	μA μA
V_{SAT}	Switch Saturation Voltage	$I_{SW} = 2.0\text{A}$ $V_{COMP} = 1.2\text{V}$	0.5		0.75 1.0	V V
I_{CL}	NPN Switch Current Limit	$V_{COMP} = 2.0\text{V}$	4.3	3.7 3.0	5.3 6.0	A A

Note 1: Absolute Maximum Ratings indicate limits beyond which damage to the device may occur. Operating ratings indicate conditions the device is intended to be functional, but device parameter specifications may not be guaranteed under these conditions. For guaranteed specifications and test conditions, see the Electrical Characteristics.

Note 2: All limits guaranteed at room temperature (standard typeface) and at temperature extremes (**boldface type**). All room temperature limits are 100% production tested. All limits at temperature extremes are guaranteed via correlation using standard Statistical Quality Control (SQC) methods.

Note 3: Junction-to-Ambient thermal resistance with approximately 1 square inch of p.c. board copper surrounding the leads. Additional copper area will lower thermal resistance further.

Note 4: A 1.0 M Ω resistor is connected to the compensation pin (which is the error amplifier's output) to ensure accuracy in measuring A_{VOL} . In actual applications, this pin's load resistance should be $\geq 10\text{ M}\Omega$, resulting in A_{VOL} that is typically twice the guaranteed minimum limit.

EEPW.com.cn 电子产品世界

Typical Performance Characteristics

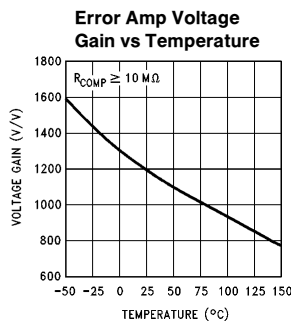
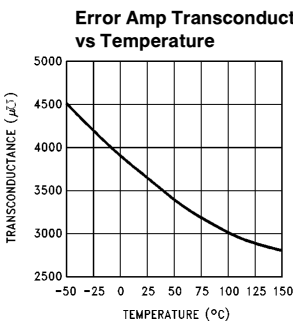
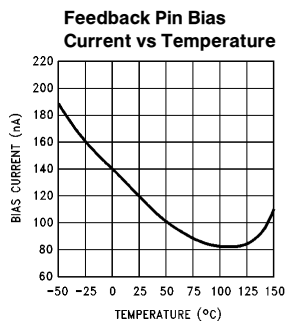
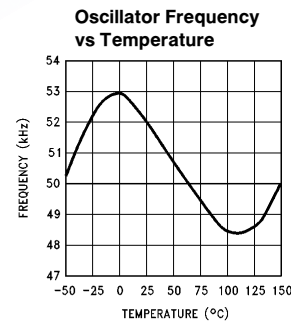
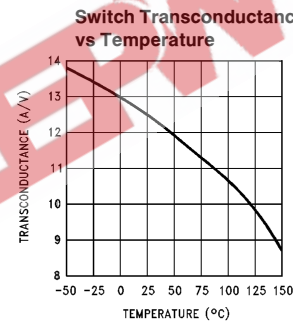
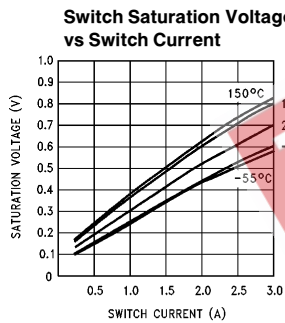
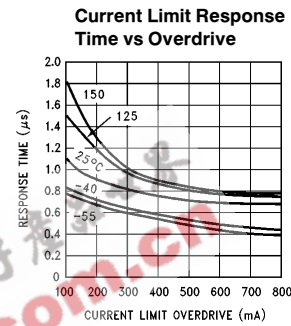
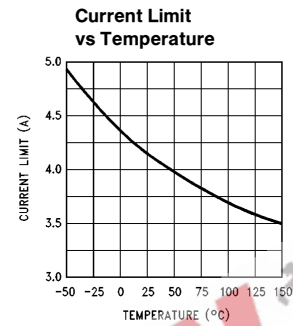
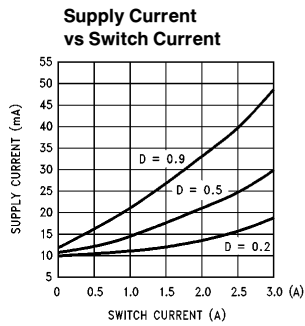
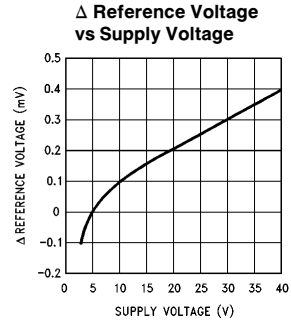
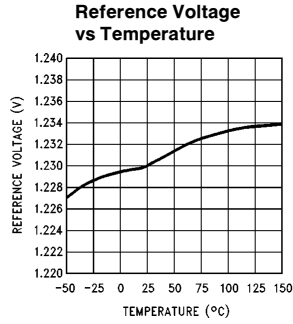
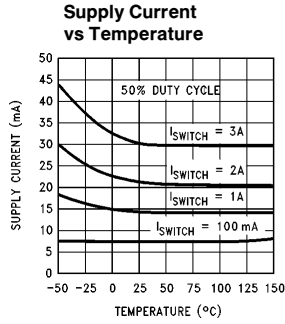

TL/H/11731-4

LM2567 Block Diagram

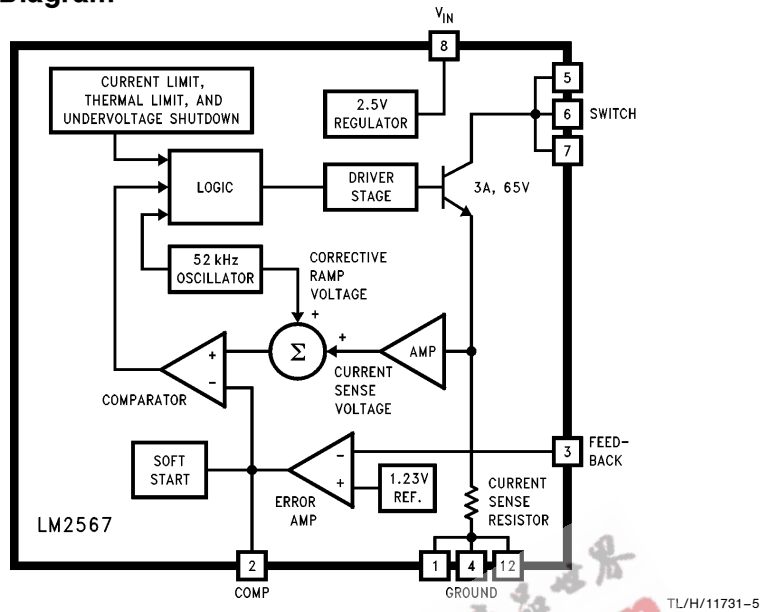

LM2567 DC-to-DC Converter* in DP8392C Typical Application

(*See Typical Application on Front Page of this Datasheet.)

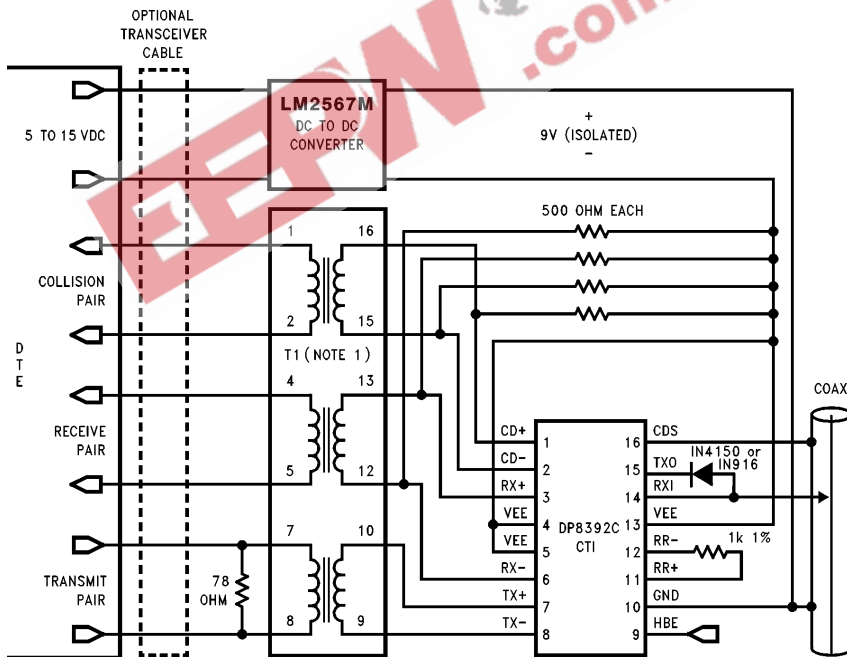

Note: T1 is a 1:1 pulse transformer, L = 100 μ H
 Pulse Engineering (San Diego) Part No. 64103
 Valor Electronics (San Diego) Part No. LT6003 or equivalent

Auxiliary Circuits

Regulator Shutdown Control from Totem-Pole Logic†

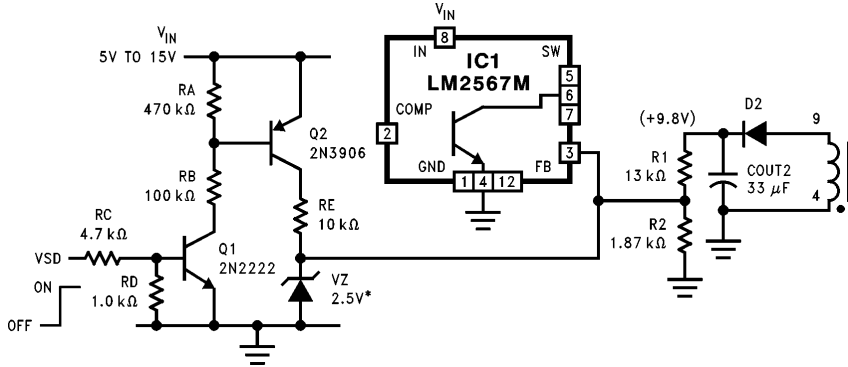

*BZX84C2V7 (in SOT-23) available from Zetex and Phillips

†Partial regulator circuit shown.

TL/H/11731-9

Regulator Shutdown Control from Open-Collector Logic†

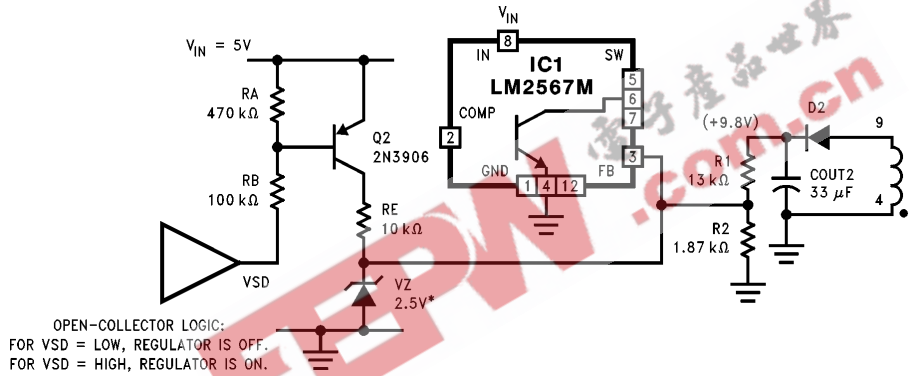

*BZX84C2V7 (in SOT-23) available from Zetex and Phillips

†Partial regulator circuit shown.

TL/H/11731-10

Typical Performance Characteristics of LM2567 DC-to-DC Converter

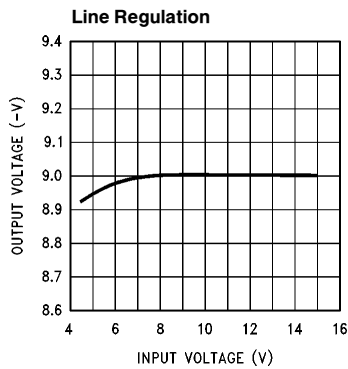

TL/H/11731-7

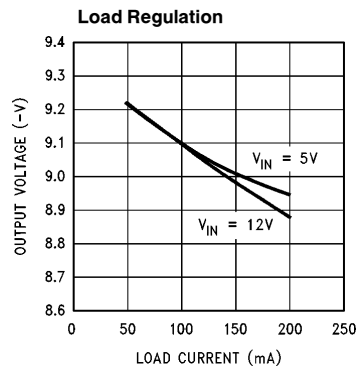

TL/H/11731-8

EEPW 电子产品世界
.com.cn

Physical Dimensions inches (millimeters)

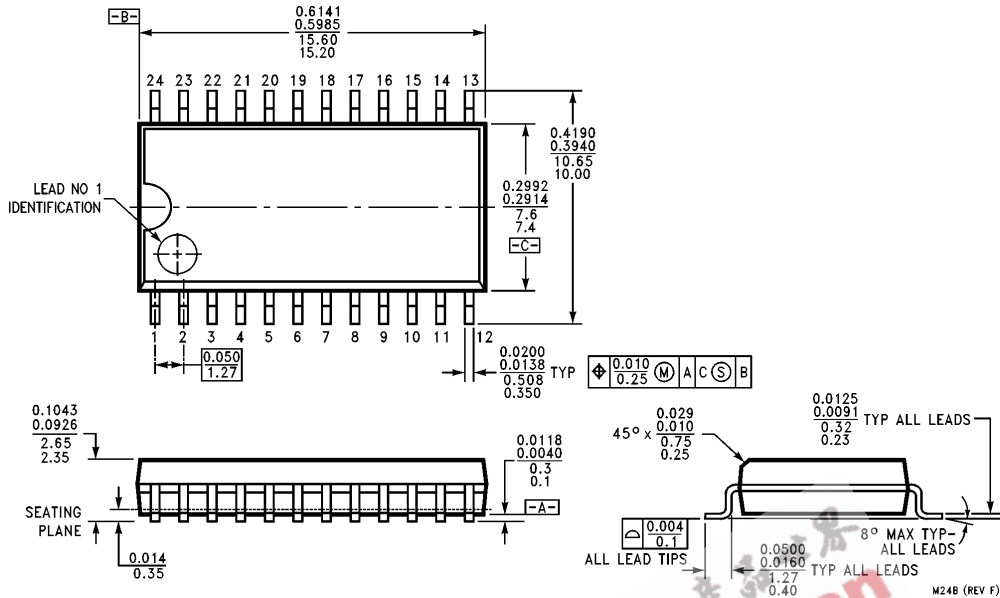

0.300 Wide SO Package (M)
Order Number LM2567M
NS Package Number M24B

LIFE SUPPORT POLICY

NATIONAL'S PRODUCTS ARE NOT AUTHORIZED FOR USE AS CRITICAL COMPONENTS IN LIFE SUPPORT DEVICES OR SYSTEMS WITHOUT THE EXPRESS WRITTEN APPROVAL OF THE PRESIDENT OF NATIONAL SEMICONDUCTOR CORPORATION. As used herein:

1. Life support devices or systems are devices or systems which, (a) are intended for surgical implant into the body, or (b) support or sustain life, and whose failure to perform, when properly used in accordance with instructions for use provided in the labeling, can be reasonably expected to result in a significant injury to the user.
2. A critical component is any component of a life support device or system whose failure to perform can be reasonably expected to cause the failure of the life support device or system, or to affect its safety or effectiveness.



National Semiconductor Corporation
 1111 West Bardin Road
 Arlington, TX 76017
 Tel: 1(800) 272-9959
 Fax: 1(800) 737-7018

National Semiconductor Europe
 Fax: (+49) 0-180-530 85 86
 Email: cnjwge@levm2.nsc.com
 Deutsch Tel: (+49) 0-180-530 85 85
 English Tel: (+49) 0-180-532 78 32
 Français Tel: (+49) 0-180-532 93 58
 Italiano Tel: (+49) 0-180-534 16 80

National Semiconductor Hong Kong Ltd.
 13th Floor, Straight Block,
 Ocean Centre, 5 Canton Rd.
 Tsimshatsui, Kowloon
 Hong Kong
 Tel: (852) 2737-1600
 Fax: (852) 2736-9960

National Semiconductor Japan Ltd.
 Tel: 81-043-299-2309
 Fax: 81-043-299-2408