

LM124, LM124A, LM224, LM224A, LM324, LM324A, LM2902, LM2902V, LM224K, LM224KA, LM324K, LM324KA, LM2902K, LM2902KV, LM2902KAV

QUADRUPLE OPERATIONAL AMPLIFIERS

SLOS066R – SEPTEMBER 1975 – REVISED JANUARY 2005

- **2-kV ESD Protection for:**
 - LM224K, LM224KA
 - LM324K, LM324KA
 - LM2902K, LM2902KV, LM2902KAV
- **Wide Supply Ranges**
 - Single Supply . . . 3 V to 32 V (26 V for LM2902)
 - Dual Supplies . . . ± 1.5 V to ± 16 V (± 13 V for LM2902)
- **Low Supply-Current Drain Independent of Supply Voltage . . . 0.8 mA Typ**
- **Common-Mode Input Voltage Range Includes Ground, Allowing Direct Sensing Near Ground**
- **Low Input Bias and Offset Parameters**
 - Input Offset Voltage . . . 3 mV Typ
A Versions . . . 2 mV Typ
 - Input Offset Current . . . 2 nA Typ
 - Input Bias Current . . . 20 nA Typ
A Versions . . . 15 nA Typ
- **Differential Input Voltage Range Equal to Maximum-Rated Supply Voltage . . . 32 V (26 V for LM2902)**
- **Open-Loop Differential Voltage Amplification . . . 100 V/mV Typ**
- **Internal Frequency Compensation**

description/ordering information

These devices consist of four independent high-gain frequency-compensated operational amplifiers that are designed specifically to operate from a single supply over a wide range of voltages. Operation from split supplies also is possible if the difference between the two supplies is 3 V to 32 V (3 V to 26 V for the LM2902), and V_{CC} is at least 1.5 V more positive than the input common-mode voltage. The low supply-current drain is independent of the magnitude of the supply voltage.

Applications include transducer amplifiers, dc amplification blocks, and all the conventional operational-amplifier circuits that now can be more easily implemented in single-supply-voltage systems. For example, the LM124 can be operated directly from the standard 5-V supply that is used in digital systems and provides the required interface electronics, without requiring additional ± 15 -V supplies.

LM124 . . . D, J, OR W PACKAGE
LM124A . . . J PACKAGE
LM224, LM224A, LM224K, LM224KA . . . D OR N PACKAGE
LM324, LM324K . . . D, N, NS, OR PW PACKAGE
LM324A . . . D, DB, N, NS, OR PW PACKAGE
LM324KA . . . D, N, NS, OR PW PACKAGE
LM2902 . . . D, N, NS, OR PW PACKAGE
LM2902K . . . D, DB, N, NS, OR PW PACKAGE
LM2902KV, LM2902KAV . . . D OR PW PACKAGE

(TOP VIEW)

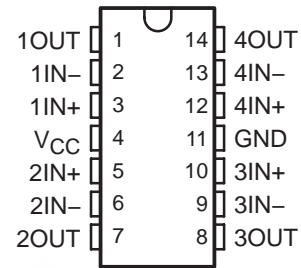

LM124, LM124A . . . FK PACKAGE
(TOP VIEW)

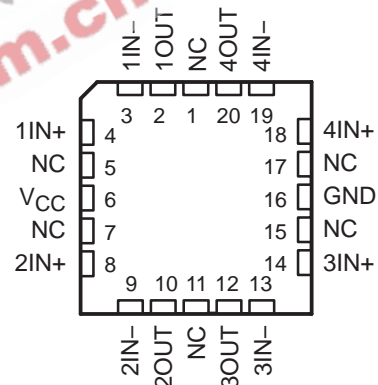

NC – No internal connection

**LM124, LM124A, LM224, LM224A, LM324, LM324A, LM2902, LM2902V,
LM224K, LM224KA, LM324K, LM324KA, LM2902K, LM2902KV, LM2902KAV**
QUADRUPLE OPERATIONAL AMPLIFIERS

SLOS066R – SEPTEMBER 1975 – REVISED JANUARY 2005

description/ordering information (continued)

ORDERING INFORMATION

TA	V _{IO} max AT 25°C	MAX TESTED V _{CC}	PACKAGE†		ORDERABLE PART NUMBER	TOP-SIDE MARKING
0°C to 70°C	7 mV	30 V	PDIP (N)	Tube of 25	LM324N	LM324N
						LM324KN
			SOIC (D)	Tube of 50	LM324D	LM324
				Reel of 2500	LM324DR	
				Tube of 50	LM324KD	LM324K
				Reel of 2500	LM324KDR	
			SOP (NS)	Reel of 2000	LM324NSR	LM324
				Tube of 50	LM324KNS	LM324K
				Reel of 2000	LM324KNSR	
			TSSOP (PW)	Tube of 90	LM324PW	L324
				Reel of 2000	LM324PWR	
				Tube of 90	LM324KPW	L324K
	Reel of 2000	LM324KPWR				
	3 mV	30 V	PDIP (N)	Tube of 25	LM324AN	LM324AN
				Tube of 25	LM324KAN	LM324KAN
			SOIC (D)	Tube of 50	LM324AD	LM324A
				Reel of 2500	LM324ADR	
				Tube of 50	LM324KAD	LM324KA
				Reel of 2500	LM324KADR	
			SOP (NS)	Reel of 2000	LM324ANSR	LM324A
Tube of 50				LM324KANS	LM324KA	
Reel of 2000				LM324KANSR		
SSOP (DB)			Reel of 2000	LM324ADBR	LM324A	
TSSOP (PW)			Tube of 90	LM324APW	L324A	
			Reel of 2000	LM324APWR		
	Tube of 90	LM324KAPW	L324KA			
	Reel of 2000	LM324KAPWR				
-25°C to 85°C	5 mV	30 V	PDIP (N)	Tube of 25	LM224N	LM224N
						LM224KN
			SOIC (D)	Tube of 50	LM224D	LM224
				Reel of 2500	LM224DR	
				Tube of 50	LM224KD	LM224K
				Reel of 2500	LM224KDR	
	3 mV	30 V	PDIP (N)	Tube of 25	LM224AN	LM224AN
				Tube of 25	LM224KAN	LM224KAN
			SOIC (D)	Tube of 50	LM224AD	LM224A
				Reel of 2500	LM224ADR	
				Tube of 50	LM224KAD	LM224KA
				Reel of 2500	LM224KADR	

† Package drawings, standard packing quantities, thermal data, symbolization, and PCB design guidelines are available at www.ti.com/sc/package.

**LM124, LM124A, LM224, LM224A, LM324, LM324A, LM2902, LM2902V,
LM224K, LM224KA, LM324K, LM324KA, LM2902K, LM2902KV, LM2902KAV**
QUADRUPLE OPERATIONAL AMPLIFIERS

SLOS066R – SEPTEMBER 1975 – REVISED JANUARY 2005

ORDERING INFORMATION (CONTINUED)

T_A	V_{IOmax} AT 25°C	MAX TESTED V_{CC}	PACKAGE†		ORDERABLE PART NUMBER	TOP-SIDE MARKING
-40°C to 125°C	7 mV	26 V	PDIP (N)	Tube of 25	LM2902N	LM2902N
				Tube of 25	LM2902KN	LM2902KN
			SOIC (D)	Tube of 50	LM2902D	LM2902
				Reel of 2500	LM2902DR	
				Tube of 50	LM2902KD	LM2902K
				Reel of 2500	LM2902KDR	
			SOP (NS)	Reel of 2000	LM2902NSR	LM2902
				Tube of 50	LM2902KNS	LM2902K
				Reel of 2000	LM2902KNSR	
			SSOP (DB)	Tube of 80	LM2902KDB	L2902K
				Reel of 2000	LM2902KDBR	
			TSSOP (PW)	Tube of 90	LM2902PW	L2902
	Reel of 2000	LM2902PWR				
	Tube of 90	LM2902KPW		L2902K		
	Reel of 2000	LM2902KPWR				
	32 V	SOIC (D)	Reel of 2500	LM2902KVQDR	L2902KV	
TSSOP (PW)		Reel of 2000	LM2902KVQPWR	L2902KV		
2 mV	32 V	SOIC (D)	Reel of 2500	LM2902KAVQDR	L2902KA	
		TSSOP (PW)	Reel of 2000	LM2902KAVQPWR	L2902KA	
-55°C to 125°C	5 mV	30 V	CDIP (J)	Tube of 25	LM124J	LM124J
			CFP (W)	Tube of 25	LM124W	LM124W
			LCCC (FK)	Tube of 55	LM124FK	LM124FK
			SOIC (D)	Tube of 50	LM124D	LM124
	Reel of 2500	LM124DR				
	2 mV	30 V	CDIP (J)	Tube of 25	LM124AJ	LM124AJ
LCCC (FK)			Tube of 55	LM124AFK	LM124AFK	

† Package drawings, standard packing quantities, thermal data, symbolization, and PCB design guidelines are available at www.ti.com/sc/package.

symbol (each amplifier)

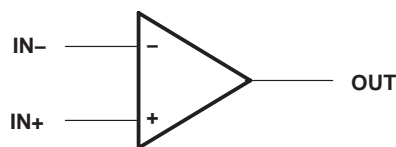

**LM124, LM124A, LM224, LM224A, LM324, LM324A, LM2902, LM2902V,
LM224K, LM224KA, LM324K, LM324KA, LM2902K, LM2902KV, LM2902KAV**
QUADRUPLE OPERATIONAL AMPLIFIERS

SLOS066R – SEPTEMBER 1975 – REVISED JANUARY 2005

schematic (each amplifier)

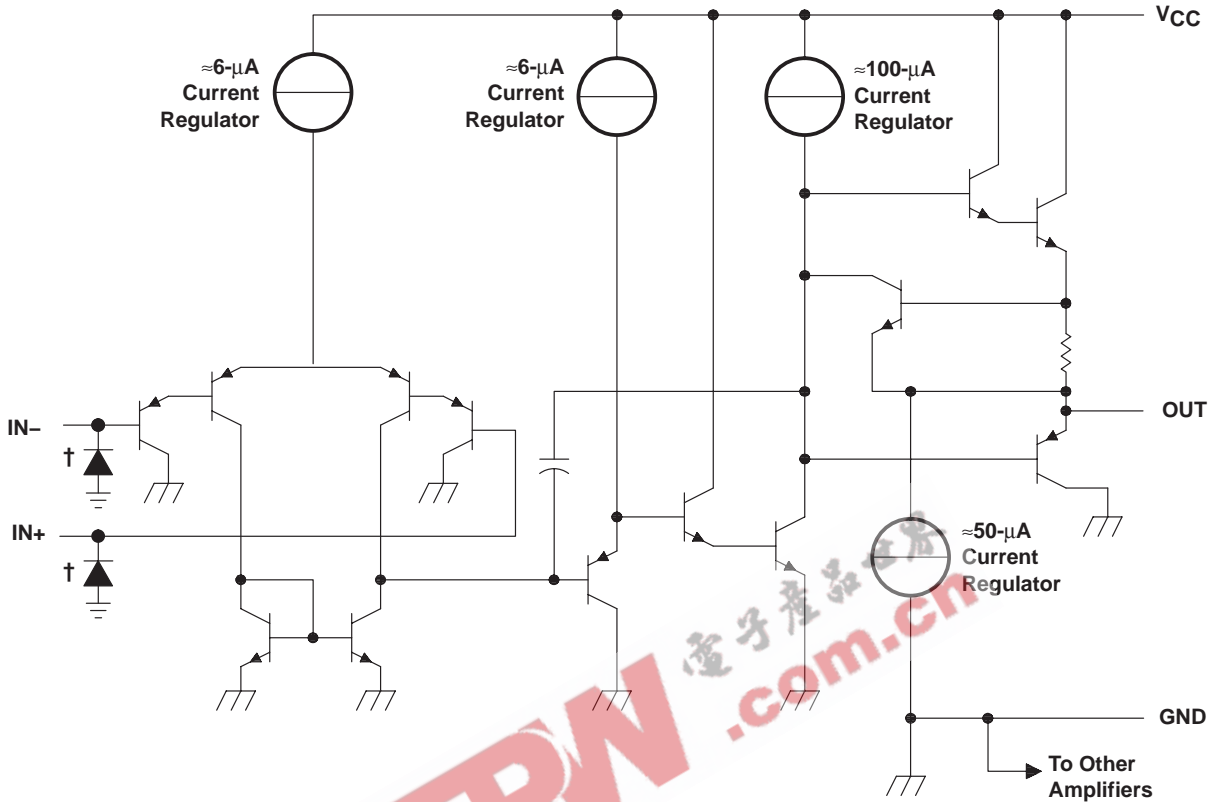

COMPONENT COUNT (total device)	
Epi-FET	1
Transistors	95
Diodes	4
Resistors	11
Capacitors	4

† ESD protection cells - available on LM324K and LM324KA only

**LM124, LM124A, LM224, LM224A, LM324, LM324A, LM2902, LM2902V,
LM224K, LM224KA, LM324K, LM324KA, LM2902K, LM2902KV, LM2902KAV**
QUADRUPLE OPERATIONAL AMPLIFIERS

SLOS066R – SEPTEMBER 1975 – REVISED JANUARY 2005

absolute maximum ratings over operating free-air temperature range (unless otherwise noted)†

		LM2902	ALL OTHER DEVICES	UNIT
Supply voltage, V_{CC} (see Note 1)		±13 or 26	±16 or 32	V
Differential input voltage, V_{ID} (see Note 2)		±26	±32	V
Input voltage, V_I (either input)		–0.3 to 26	–0.3 to 32	V
Duration of output short circuit (one amplifier) to ground at (or below) $T_A = 25^\circ\text{C}$, $V_{CC} \leq 15\text{ V}$ (see Note 3)		Unlimited	Unlimited	
Package thermal impedance, θ_{JA} (see Notes 4 and 5)	D package	86	86	$^\circ\text{C/W}$
	DB package	96	96	
	N package	80	80	
	NS package	76	76	
	PW package	113	113	
Package thermal impedance, θ_{JC} (see Notes 6 and 7)	FK package		5.61	$^\circ\text{C/W}$
	J package		15.05	
	W package		14.65	
Operating virtual junction temperature, T_J		150	150	$^\circ\text{C}$
Case temperature for 60 seconds	FK package		260	$^\circ\text{C}$
Lead temperature 1,6 mm (1/16 inch) from case for 60 seconds	J or W package	300	300	$^\circ\text{C}$
Storage temperature range, T_{stg}		–65 to 150	–65 to 150	$^\circ\text{C}$

† Stresses beyond those listed under “absolute maximum ratings” may cause permanent damage to the device. These are stress ratings only, and functional operation of the device at these or any other conditions beyond those indicated under “recommended operating conditions” is not implied. Exposure to absolute-maximum-rated conditions for extended periods may affect device reliability.

- NOTES:
1. All voltage values (except differential voltages and V_{CC} specified for the measurement of I_{OS}) are with respect to the network GND.
 2. Differential voltages are at $IN+$, with respect to $IN-$.
 3. Short circuits from outputs to V_{CC} can cause excessive heating and eventual destruction.
 4. Maximum power dissipation is a function of $T_J(\text{max})$, θ_{JA} , and T_A . The maximum allowable power dissipation at any allowable ambient temperature is $P_D = (T_J(\text{max}) - T_A)/\theta_{JA}$. Operating at the absolute maximum T_J of 150°C can affect reliability.
 5. The package thermal impedance is calculated in accordance with JESD 51-7.
 6. Maximum power dissipation is a function of $T_J(\text{max})$, θ_{JC} , and T_C . The maximum allowable power dissipation at any allowable case temperature is $P_D = (T_J(\text{max}) - T_C)/\theta_{JC}$. Operating at the absolute maximum T_J of 150°C can affect reliability.
 7. The package thermal impedance is calculated in accordance with MIL-STD-883.

ESD protection

TEST CONDITIONS		TYP	UNIT
Human-Body Model	LM224K, LM224KA, LM324K, LM324KA, LM2902K, LM2902KV, LM2902KAV	±2	kV

LM124, LM124A, LM224, LM224A, LM324, LM324A, LM2902, LM2902V, LM224K, LM224KA, LM324K, LM324KA, LM2902K, LM2902KV, LM2902KAV

QUADRUPLE OPERATIONAL AMPLIFIERS

SLOS066R – SEPTEMBER 1975 – REVISED JANUARY 2005

electrical characteristics at specified free-air temperature, $V_{CC} = 5\text{ V}$ (unless otherwise noted)

PARAMETER	TEST CONDITIONS†	T_A ‡	LM124 LM224			LM324 LM324K			UNIT		
			MIN	TYP§	MAX	MIN	TYP§	MAX			
V_{IO} Input offset voltage	$V_{CC} = 5\text{ V to MAX}$, $V_{IC} = V_{ICRmin}$, $V_O = 1.4\text{ V}$	25°C		3	5		3	7	mV		
		Full range			7			9			
I_{IO} Input offset current	$V_O = 1.4\text{ V}$	25°C		2	30		2	50	nA		
		Full range			100			150			
I_{IB} Input bias current	$V_O = 1.4\text{ V}$	25°C		-20	-150		-20	-250	nA		
		Full range			-300			-500			
V_{ICR} Common-mode input voltage range	$V_{CC} = 5\text{ V to MAX}$	25°C		0 to $V_{CC} - 1.5$			0 to $V_{CC} - 1.5$		V		
		Full range		0 to $V_{CC} - 2$			0 to $V_{CC} - 2$				
V_{OH} High-level output voltage	$R_L = 2\text{ k}\Omega$	25°C							V		
	$R_L = 10\text{ k}\Omega$	25°C									
	$V_{CC} = \text{MAX}$	$R_L = 2\text{ k}\Omega$	Full range		26			26			
		$R_L \geq 10\text{ k}\Omega$	Full range		27	28		27		28	
V_{OL} Low-level output voltage	$R_L \leq 10\text{ k}\Omega$	Full range		5	20		5	20	mV		
A_{VD} Large-signal differential voltage amplification	$V_{CC} = 15\text{ V}$, $V_O = 1\text{ V to }11\text{ V}$, $R_L \geq 2\text{ k}\Omega$	25°C		50	100		25	100	V/mV		
		Full range		25			15				
CMRR Common-mode rejection ratio	$V_{IC} = V_{ICRmin}$	25°C		70	80		65	80	dB		
k_{SVR} Supply-voltage rejection ratio ($\Delta V_{CC}/\Delta V_{IO}$)		25°C		65	100		65	100	dB		
V_{O1}/V_{O2} Crosstalk attenuation	$f = 1\text{ kHz to }20\text{ kHz}$	25°C			120			120	dB		
I_O Output current	$V_{CC} = 15\text{ V}$, $V_{ID} = 1\text{ V}$, $V_O = 0$	Source	25°C		-20	-30	-60	-20	-30	-60	mA
		Full range			-10			-10			
	Sink	25°C		10	20		10	20			
		Full range			5			5			
	$V_{ID} = -1\text{ V}$, $V_O = 200\text{ mV}$	25°C		12	30		12	30	μA		
I_{OS} Short-circuit output current	V_{CC} at 5 V, $V_O = 0$, GND at -5 V	25°C		± 40	± 60		± 40	± 60	mA		
I_{CC} Supply current (four amplifiers)	$V_O = 2.5\text{ V}$, No load	Full range		0.7	1.2		0.7	1.2	mA		
	$V_{CC} = \text{MAX}$, $V_O = 0.5 V_{CC}$, No load	Full range		1.4	3		1.4	3			

† All characteristics are measured under open-loop conditions, with zero common-mode input voltage, unless otherwise specified. MAX V_{CC} for testing purposes is 26 V for LM2902 and 30 V for the others.

‡ Full range is -55°C to 125°C for LM124, -25°C to 85°C for LM224, and 0°C to 70°C for LM324.

§ All typical values are at $T_A = 25^\circ\text{C}$.

**LM124, LM124A, LM224, LM224A, LM324, LM324A, LM2902, LM2902V,
LM224K, LM224KA, LM324K, LM324KA, LM2902K, LM2902KV, LM2902KAV**
QUADRUPLE OPERATIONAL AMPLIFIERS

SLOS066R – SEPTEMBER 1975 – REVISED JANUARY 2005

electrical characteristics at specified free-air temperature, $V_{CC} = 5\text{ V}$ (unless otherwise noted)

PARAMETER	TEST CONDITIONS†		T_A ‡	LM2902			LM2902V			UNIT
				MIN	TYP§	MAX	MIN	TYP§	MAX	
V_{IO} Input offset voltage	$V_{CC} = 5\text{ V to MAX}$, $V_{IC} = V_{ICRmin}$, $V_O = 1.4\text{ V}$	Non-A-suffix devices	25°C	3	7		3	7	mV	
			Full range			10	10			
		A-suffix devices	25°C				1	2		
			Full range					4		
$\Delta V_{IO}/\Delta T$ Input offset voltage temperature drift	$R_S = 0\ \Omega$		Full range				7	$\mu\text{V}/^\circ\text{C}$		
I_{IO} Input offset current	$V_O = 1.4\text{ V}$		25°C	2	50		2	50	nA	
			Full range			300	150			
$\Delta I_{IO}/\Delta T$ Input offset current temperature drift			Full range				10	$\text{pA}/^\circ\text{C}$		
I_{IB} Input bias current	$V_O = 1.4\text{ V}$		25°C	-20	-250		-20	-250	nA	
			Full range			-500	-500			
V_{ICR} Common-mode input voltage range	$V_{CC} = 5\text{ V to MAX}$		25°C	0 to $V_{CC} - 1.5$		0 to $V_{CC} - 1.5$		V		
			Full range	0 to $V_{CC} - 2$		0 to $V_{CC} - 2$				
V_{OH} High-level output voltage	$R_L = 2\text{ k}\Omega$		25°C					V		
			25°C	$V_{CC} - 1.5$		$V_{CC} - 1.5$				
		$V_{CC} = \text{MAX}$	$R_L = 2\text{ k}\Omega$	Full range	22	26				
			$R_L \geq 10\text{ k}\Omega$	Full range	23	24	27			
V_{OL} Low-level output voltage	$R_L \leq 10\text{ k}\Omega$		Full range	5	20		5	20	mV	
A_{VD} Large-signal differential voltage amplification	$V_{CC} = 15\text{ V}$, $V_O = 1\text{ V to }11\text{ V}$, $R_L \geq 2\text{ k}\Omega$		25°C	25	100		25	100	V/mV	
			Full range	15			15			
CMRR Common-mode rejection ratio	$V_{IC} = V_{ICRmin}$		25°C	50	80		60	80	dB	
k_{SVR} Supply-voltage rejection ratio ($\Delta V_{CC}/\Delta V_{IO}$)			25°C	50	100		60	100	dB	
V_{O1}/V_{O2} Crosstalk attenuation	$f = 1\text{ kHz to }20\text{ kHz}$		25°C		120		120		dB	
I_O Output current	$V_{CC} = 15\text{ V}$, $V_{ID} = 1\text{ V}$, $V_O = 0$	Source	25°C	-20	-30	-60	-20	-30	-60	mA
			Full range	-10			-10			
	$V_{CC} = 15\text{ V}$, $V_{ID} = -1\text{ V}$, $V_O = 15\text{ V}$	Sink	25°C	10	20		10	20		
			Full range	5			5			
	$V_{ID} = -1\text{ V}$, $V_O = 200\text{ mV}$		25°C		30		12	40	μA	
I_{OS} Short-circuit output current	V_{CC} at 5 V, GND at -5 V	$V_O = 0$,	25°C		± 40	± 60		± 40	± 60	mA
I_{CC} Supply current (four amplifiers)	$V_O = 2.5\text{ V}$, $V_{CC} = \text{MAX}$, $V_O = 0.5 V_{CC}$	No load	Full range		0.7	1.2		0.7	1.2	mA
		No load	Full range		1.4	3		1.4	3	

† All characteristics are measured under open-loop conditions, with zero common-mode input voltage, unless otherwise specified. MAX V_{CC} for testing purposes is 26 V for LM2902 and 32 V for LM2902V.

‡ Full range is -40°C to 125°C for LM2902.

§ All typical values are at $T_A = 25^\circ\text{C}$.

LM124, LM124A, LM224, LM224A, LM324, LM324A, LM2902, LM2902V, LM224K, LM224KA, LM324K, LM324KA, LM2902K, LM2902KV, LM2902KAV

QUADRUPLE OPERATIONAL AMPLIFIERS

SLOS066R – SEPTEMBER 1975 – REVISED JANUARY 2005

electrical characteristics at specified free-air temperature, $V_{CC} = 5\text{ V}$ (unless otherwise noted)

PARAMETER	TEST CONDITION†	T _A ‡	LM124A			LM224A			LM324A, LM324KA			UNIT
			MIN	TYP§	MAX	MIN	TYP§	MAX	MIN	TYP§	MAX	
V _{IO}	V _{CC} = 5 V to 30 V, V _{IC} = V _{ICRmin} , V _O = 1.4 V	25°C		2	2	3		2	2	3	mV	
		Full range		4	4		4	4	5			
I _{IO}	V _O = 1.4 V	25°C		10	10	15		2	2	30	nA	
Full range			30	30		30	75					
I _{IB}	V _O = 1.4 V	25°C		-50	-50	-80		-15	-15	-100	nA	
Full range			-100	-100		-100	-200					
V _{ICR}	V _{CC} = 30 V	25°C	0 to V _{CC} - 1.5				0 to V _{CC} - 1.5				V	
		Full range	0 to V _{CC} - 2				0 to V _{CC} - 2					
V _{OH}	R _L = 2 kΩ V _{CC} = 30 V	25°C	0 to V _{CC} - 1.5				0 to V _{CC} - 1.5				V	
		Full range	26	26		26	26					
V _{OL}	R _L ≤ 10 kΩ V _{CC} = 30 V	25°C	0 to V _{CC} - 1.5				0 to V _{CC} - 1.5				V	
		Full range	27	27		27	27					
A _{V/D}	V _{CC} = 15 V, V _O = 1 V to 11 V, R _L ≥ 2 kΩ	25°C	50	100		50	100		25	100	mV	
		Full range	25	25		25	25		15	15		
CMRR	V _{IC} = V _{ICRmin}	25°C	70	80		70	80		65	80	dB	
k _{SVR}	Supply-voltage rejection ratio (ΔV _{CC} /ΔV _{IO})	25°C	65	100		65	100		65	100	dB	
V _{O1} /V _{O2}	Crosstalk attenuation	25°C	120	120		120	120		120	120	dB	
I _O	V _{CC} = 15 V, V _{ID} = 1 V, V _O = 0	25°C	-20	-20	-30	-20	-30	-60	-20	-30	-60	mA
		Full range	-10	-10		-10	-10		-10	-10		
I _{OS}	V _{CC} = 15 V, V _{ID} = -1 V, V _O = 15 V	25°C	10	10	20	10	20		10	20	mA	
		Full range	5	5		5	5		5	5		
I _{CC}	V _O = -1 V, V _O = 200 mV	25°C	12	12	30	12	30		12	30	μA	
		Full range	12	12		12	12		12	12		
I _{OS}	V _{CC} at 5 V, V _O = 0	25°C	±40	±40	±60	±40	±60		±40	±60	mA	
		Full range	0.7	0.7	1.2	0.7	1.2		0.7	1.2		
I _{CC}	V _{CC} = 30 V, No load	25°C	1.4	1.4	3	1.4	3		1.4	3	mA	
		Full range	1.4	1.4		1.4	1.4		1.4	1.4		

† All characteristics are measured under open-loop conditions, with zero common-mode input voltage, unless otherwise specified.

‡ Full range is -55°C to 125°C for LM124A, -25°C to 85°C for LM224A, and 0°C to 70°C for LM324A.

§ All typical values are at T_A = 25°C.

**LM124, LM124A, LM224, LM224A, LM324, LM324A, LM2902, LM2902V,
LM224K, LM224KA, LM324K, LM324KA, LM2902K, LM2902KV, LM2902KAV**
QUADRUPLE OPERATIONAL AMPLIFIERS

SLOS066R – SEPTEMBER 1975 – REVISED JANUARY 2005

operating conditions, $V_{CC} = \pm 15\text{ V}$, $T_A = 25^\circ\text{C}$

PARAMETER	TEST CONDITIONS	TYP	UNIT
SR Slew rate at unity gain	$R_L = 1\text{ M}\Omega$, $C_L = 30\text{ pF}$, $V_I = \pm 10\text{ V}$ (see Figure 1)	0.5	$\text{V}/\mu\text{s}$
B_1 Unity-gain bandwidth	$R_L = 1\text{ M}\Omega$, $C_L = 20\text{ pF}$ (see Figure 1)	1.2	MHz
V_n Equivalent input noise voltage	$R_S = 100\ \Omega$, $V_I = 0\text{ V}$, $f = 1\text{ kHz}$ (see Figure 2)	35	$\text{nV}/\sqrt{\text{Hz}}$

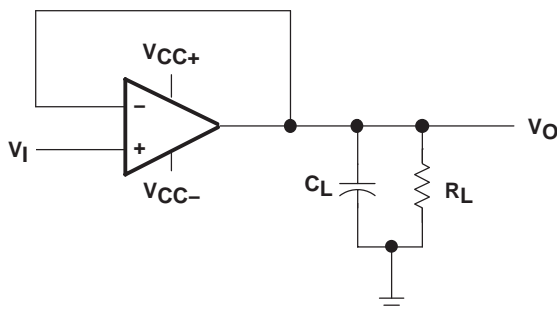

Figure 1. Unity-Gain Amplifier

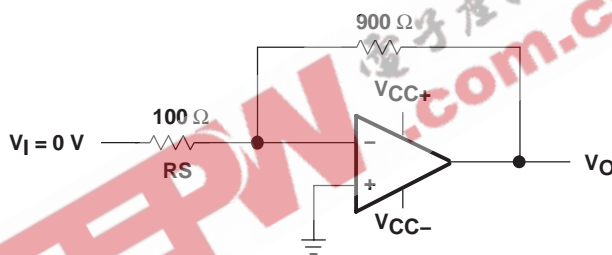

Figure 2. Noise-Test Circuit

PACKAGING INFORMATION

Orderable Device	Status ⁽¹⁾	Package Type	Package Drawing	Pins	Package Qty	Eco Plan ⁽²⁾	Lead/Ball Finish	MSL Peak Temp ⁽³⁾
5962-7704301VCA	ACTIVE	CDIP	J	14	1	TBD	A42 SNPB	N / A for Pkg Type
77043012A	ACTIVE	LCCC	FK	20	1	TBD	POST-PLATE	N / A for Pkg Type
7704301CA	ACTIVE	CDIP	J	14	1	TBD	A42 SNPB	N / A for Pkg Type
7704301DA	ACTIVE	CFP	W	14	1	TBD	A42 SNPB	N / A for Pkg Type
77043022A	ACTIVE	LCCC	FK	20	1	TBD	POST-PLATE	N / A for Pkg Type
7704302CA	ACTIVE	CDIP	J	14	1	TBD	A42 SNPB	N / A for Pkg Type
JM38510/11005BCA	ACTIVE	CDIP	J	14	1	TBD	A42 SNPB	N / A for Pkg Type
LM124ADR	OBSOLETE	SOIC	D	14		TBD	Call TI	Call TI
LM124AFKB	ACTIVE	LCCC	FK	20	1	TBD	POST-PLATE	N / A for Pkg Type
LM124AJ	ACTIVE	CDIP	J	14	1	TBD	A42 SNPB	N / A for Pkg Type
LM124AJB	ACTIVE	CDIP	J	14	1	TBD	A42 SNPB	N / A for Pkg Type
LM124D	ACTIVE	SOIC	D	14	50	TBD	CU NIPDAU	Level-3-245C-168 HR
LM124DG4	ACTIVE	SOIC	D	14	50	Green (RoHS & no Sb/Br)	CU NIPDAU	Level-1-260C-UNLIM
LM124DR	ACTIVE	SOIC	D	14	2500	TBD	CU NIPDAU	Level-3-245C-168 HR
LM124DRG4	ACTIVE	SOIC	D	14	2500	Green (RoHS & no Sb/Br)	CU NIPDAU	Level-1-260C-UNLIM
LM124FKB	ACTIVE	LCCC	FK	20	1	TBD	POST-PLATE	N / A for Pkg Type
LM124J	ACTIVE	CDIP	J	14	1	TBD	A42 SNPB	N / A for Pkg Type
LM124JB	ACTIVE	CDIP	J	14	1	TBD	A42 SNPB	N / A for Pkg Type
LM124N	OBSOLETE	PDIP	N	14		TBD	Call TI	Call TI
LM124W	ACTIVE	CFP	W	14	1	TBD	A42 SNPB	N / A for Pkg Type
LM124WB	ACTIVE	CFP	W	14	1	TBD	A42 SNPB	N / A for Pkg Type
LM224AD	ACTIVE	SOIC	D	14	50	Green (RoHS & no Sb/Br)	CU NIPDAU	Level-1-260C-UNLIM
LM224ADE4	ACTIVE	SOIC	D	14	50	Green (RoHS & no Sb/Br)	CU NIPDAU	Level-1-260C-UNLIM
LM224ADG4	ACTIVE	SOIC	D	14	50	Green (RoHS & no Sb/Br)	CU NIPDAU	Level-1-260C-UNLIM
LM224ADR	ACTIVE	SOIC	D	14	2500	Green (RoHS & no Sb/Br)	CU NIPDAU	Level-1-260C-UNLIM
LM224ADRE4	ACTIVE	SOIC	D	14	2500	Green (RoHS & no Sb/Br)	CU NIPDAU	Level-1-260C-UNLIM
LM224ADRG4	ACTIVE	SOIC	D	14	2500	Green (RoHS & no Sb/Br)	CU NIPDAU	Level-1-260C-UNLIM
LM224AN	ACTIVE	PDIP	N	14	25	Pb-Free (RoHS)	CU NIPDAU	N / A for Pkg Type
LM224ANE4	ACTIVE	PDIP	N	14	25	Pb-Free (RoHS)	CU NIPDAU	N / A for Pkg Type
LM224D	ACTIVE	SOIC	D	14	50	Green (RoHS & no Sb/Br)	CU NIPDAU	Level-1-260C-UNLIM
LM224DE4	ACTIVE	SOIC	D	14	50	Green (RoHS & no Sb/Br)	CU NIPDAU	Level-1-260C-UNLIM
LM224DG4	ACTIVE	SOIC	D	14	50	Green (RoHS & no Sb/Br)	CU NIPDAU	Level-1-260C-UNLIM
LM224DR	ACTIVE	SOIC	D	14	2500	Green (RoHS & no Sb/Br)	CU NIPDAU	Level-1-260C-UNLIM

Orderable Device	Status ⁽¹⁾	Package Type	Package Drawing	Pins	Package Qty	Eco Plan ⁽²⁾	Lead/Ball Finish	MSL Peak Temp ⁽³⁾
						no Sb/Br)		
LM224DRE4	ACTIVE	SOIC	D	14	2500	Green (RoHS & no Sb/Br)	CU NIPDAU	Level-1-260C-UNLIM
LM224DRG4	ACTIVE	SOIC	D	14	2500	Green (RoHS & no Sb/Br)	CU NIPDAU	Level-1-260C-UNLIM
LM224KAD	ACTIVE	SOIC	D	14	50	Green (RoHS & no Sb/Br)	CU NIPDAU	Level-1-260C-UNLIM
LM224KADE4	ACTIVE	SOIC	D	14	50	Green (RoHS & no Sb/Br)	CU NIPDAU	Level-1-260C-UNLIM
LM224KADG4	ACTIVE	SOIC	D	14	50	Green (RoHS & no Sb/Br)	CU NIPDAU	Level-1-260C-UNLIM
LM224KADR	ACTIVE	SOIC	D	14	2500	Green (RoHS & no Sb/Br)	CU NIPDAU	Level-1-260C-UNLIM
LM224KADRE4	ACTIVE	SOIC	D	14	2500	Green (RoHS & no Sb/Br)	CU NIPDAU	Level-1-260C-UNLIM
LM224KADRG4	ACTIVE	SOIC	D	14	2500	Green (RoHS & no Sb/Br)	CU NIPDAU	Level-1-260C-UNLIM
LM224KAN	ACTIVE	PDIP	N	14	25	Pb-Free (RoHS)	CU NIPDAU	N / A for Pkg Type
LM224KANE4	ACTIVE	PDIP	N	14	25	Pb-Free (RoHS)	CU NIPDAU	N / A for Pkg Type
LM224KD	ACTIVE	SOIC	D	14	50	Green (RoHS & no Sb/Br)	CU NIPDAU	Level-1-260C-UNLIM
LM224KDE4	ACTIVE	SOIC	D	14	50	Green (RoHS & no Sb/Br)	CU NIPDAU	Level-1-260C-UNLIM
LM224KDG4	ACTIVE	SOIC	D	14	50	Green (RoHS & no Sb/Br)	CU NIPDAU	Level-1-260C-UNLIM
LM224KDR	ACTIVE	SOIC	D	14	2500	Green (RoHS & no Sb/Br)	CU NIPDAU	Level-1-260C-UNLIM
LM224KDRE4	ACTIVE	SOIC	D	14	2500	Green (RoHS & no Sb/Br)	CU NIPDAU	Level-1-260C-UNLIM
LM224KDRG4	ACTIVE	SOIC	D	14	2500	Green (RoHS & no Sb/Br)	CU NIPDAU	Level-1-260C-UNLIM
LM224KN	ACTIVE	PDIP	N	14	25	Pb-Free (RoHS)	CU NIPDAU	N / A for Pkg Type
LM224KNE4	ACTIVE	PDIP	N	14	25	Pb-Free (RoHS)	CU NIPDAU	N / A for Pkg Type
LM224N	ACTIVE	PDIP	N	14	25	Pb-Free (RoHS)	CU NIPDAU	N / A for Pkg Type
LM224NE4	ACTIVE	PDIP	N	14	25	Pb-Free (RoHS)	CU NIPDAU	N / A for Pkg Type
LM2902D	ACTIVE	SOIC	D	14	50	Green (RoHS & no Sb/Br)	CU NIPDAU	Level-1-260C-UNLIM
LM2902DE4	ACTIVE	SOIC	D	14	50	Green (RoHS & no Sb/Br)	CU NIPDAU	Level-1-260C-UNLIM
LM2902DG4	ACTIVE	SOIC	D	14	50	Green (RoHS & no Sb/Br)	CU NIPDAU	Level-1-260C-UNLIM
LM2902DR	ACTIVE	SOIC	D	14	2500	Green (RoHS & no Sb/Br)	CU NIPDAU	Level-1-260C-UNLIM
LM2902DRE4	ACTIVE	SOIC	D	14	2500	Green (RoHS & no Sb/Br)	CU NIPDAU	Level-1-260C-UNLIM

Orderable Device	Status ⁽¹⁾	Package Type	Package Drawing	Pins	Package Qty	Eco Plan ⁽²⁾	Lead/Ball Finish	MSL Peak Temp ⁽³⁾
LM2902DRG4	ACTIVE	SOIC	D	14	2500	Green (RoHS & no Sb/Br)	CU NIPDAU	Level-1-260C-UNLIM
LM2902KAVQDR	NRND	SOIC	D	14	2500	Pb-Free (RoHS)	CU NIPDAU	Level-2-250C-1 YEAR/ Level-1-235C-UNLIM
LM2902KAVQDRG4	ACTIVE	SOIC	D	14	2500	Green (RoHS & no Sb/Br)	CU NIPDAU	Level-1-260C-UNLIM
LM2902KAVQPWR	ACTIVE	TSSOP	PW	14	2000	TBD	CU NIPDAU	Level-1-250C-UNLIM
LM2902KAVQPWRG4	ACTIVE	TSSOP	PW	14	2000	Green (RoHS & no Sb/Br)	CU NIPDAU	Level-1-260C-UNLIM
LM2902KD	ACTIVE	SOIC	D	14	50	Green (RoHS & no Sb/Br)	CU NIPDAU	Level-1-260C-UNLIM
LM2902KDB	ACTIVE	SSOP	DB	14	80	Green (RoHS & no Sb/Br)	CU NIPDAU	Level-1-260C-UNLIM
LM2902KDBE4	ACTIVE	SSOP	DB	14	80	Green (RoHS & no Sb/Br)	CU NIPDAU	Level-1-260C-UNLIM
LM2902KDBG4	ACTIVE	SSOP	DB	14	80	Green (RoHS & no Sb/Br)	CU NIPDAU	Level-1-260C-UNLIM
LM2902KDBR	ACTIVE	SSOP	DB	14	2000	Green (RoHS & no Sb/Br)	CU NIPDAU	Level-1-260C-UNLIM
LM2902KDBRE4	ACTIVE	SSOP	DB	14	2000	Green (RoHS & no Sb/Br)	CU NIPDAU	Level-1-260C-UNLIM
LM2902KDBRG4	ACTIVE	SSOP	DB	14	2000	Green (RoHS & no Sb/Br)	CU NIPDAU	Level-1-260C-UNLIM
LM2902KDE4	ACTIVE	SOIC	D	14	50	Green (RoHS & no Sb/Br)	CU NIPDAU	Level-1-260C-UNLIM
LM2902KDG4	ACTIVE	SOIC	D	14	50	Green (RoHS & no Sb/Br)	CU NIPDAU	Level-1-260C-UNLIM
LM2902KDR	ACTIVE	SOIC	D	14	2500	Green (RoHS & no Sb/Br)	CU NIPDAU	Level-1-260C-UNLIM
LM2902KDRE4	ACTIVE	SOIC	D	14	2500	Green (RoHS & no Sb/Br)	CU NIPDAU	Level-1-260C-UNLIM
LM2902KDRG4	ACTIVE	SOIC	D	14	2500	Green (RoHS & no Sb/Br)	CU NIPDAU	Level-1-260C-UNLIM
LM2902KN	ACTIVE	PDIP	N	14	25	Pb-Free (RoHS)	CU NIPDAU	N / A for Pkg Type
LM2902KNE4	ACTIVE	PDIP	N	14	25	Pb-Free (RoHS)	CU NIPDAU	N / A for Pkg Type
LM2902KNSR	ACTIVE	SO	NS	14	2000	Green (RoHS & no Sb/Br)	CU NIPDAU	Level-1-260C-UNLIM
LM2902KNSRE4	ACTIVE	SO	NS	14	2000	Green (RoHS & no Sb/Br)	CU NIPDAU	Level-1-260C-UNLIM
LM2902KNSRG4	ACTIVE	SO	NS	14	2000	Green (RoHS & no Sb/Br)	CU NIPDAU	Level-1-260C-UNLIM
LM2902KPW	ACTIVE	TSSOP	PW	14	90	Green (RoHS & no Sb/Br)	CU NIPDAU	Level-1-260C-UNLIM
LM2902KPWE4	ACTIVE	TSSOP	PW	14	90	Green (RoHS & no Sb/Br)	CU NIPDAU	Level-1-260C-UNLIM
LM2902KPWG4	ACTIVE	TSSOP	PW	14	90	Green (RoHS & no Sb/Br)	CU NIPDAU	Level-1-260C-UNLIM
LM2902KPWR	ACTIVE	TSSOP	PW	14	2000	Green (RoHS & no Sb/Br)	CU NIPDAU	Level-1-260C-UNLIM

Orderable Device	Status ⁽¹⁾	Package Type	Package Drawing	Pins	Package Qty	Eco Plan ⁽²⁾	Lead/Ball Finish	MSL Peak Temp ⁽³⁾
LM2902KPWRE4	ACTIVE	TSSOP	PW	14	2000	Green (RoHS & no Sb/Br)	CU NIPDAU	Level-1-260C-UNLIM
LM2902KPWRG4	ACTIVE	TSSOP	PW	14	2000	Green (RoHS & no Sb/Br)	CU NIPDAU	Level-1-260C-UNLIM
LM2902KVQDR	NRND	SOIC	D	14	2500	Pb-Free (RoHS)	CU NIPDAU	Level-2-250C-1 YEAR/ Level-1-235C-UNLIM
LM2902KVQDRG4	ACTIVE	SOIC	D	14	2500	Green (RoHS & no Sb/Br)	CU NIPDAU	Level-1-260C-UNLIM
LM2902KVQPWR	ACTIVE	TSSOP	PW	14	2000	TBD	CU NIPDAU	Level-1-250C-UNLIM
LM2902KVQPWRG4	ACTIVE	TSSOP	PW	14	2000	Green (RoHS & no Sb/Br)	CU NIPDAU	Level-1-260C-UNLIM
LM2902N	ACTIVE	PDIP	N	14	25	Pb-Free (RoHS)	CU NIPDAU	N / A for Pkg Type
LM2902NE4	ACTIVE	PDIP	N	14	25	Pb-Free (RoHS)	CU NIPDAU	N / A for Pkg Type
LM2902NSR	ACTIVE	SO	NS	14	2000	Green (RoHS & no Sb/Br)	CU NIPDAU	Level-1-260C-UNLIM
LM2902NSRG4	ACTIVE	SO	NS	14	2000	Green (RoHS & no Sb/Br)	CU NIPDAU	Level-1-260C-UNLIM
LM2902PW	ACTIVE	TSSOP	PW	14	90	Green (RoHS & no Sb/Br)	CU NIPDAU	Level-1-260C-UNLIM
LM2902PWE4	ACTIVE	TSSOP	PW	14	90	Green (RoHS & no Sb/Br)	CU NIPDAU	Level-1-260C-UNLIM
LM2902PWG4	ACTIVE	TSSOP	PW	14	90	Green (RoHS & no Sb/Br)	CU NIPDAU	Level-1-260C-UNLIM
LM2902PWLE	OBSOLETE	TSSOP	PW	14		TBD	Call TI	Call TI
LM2902PWR	ACTIVE	TSSOP	PW	14	2000	Green (RoHS & no Sb/Br)	CU NIPDAU	Level-1-260C-UNLIM
LM2902PWRE4	ACTIVE	TSSOP	PW	14	2000	Green (RoHS & no Sb/Br)	CU NIPDAU	Level-1-260C-UNLIM
LM2902PWRG4	ACTIVE	TSSOP	PW	14	2000	Green (RoHS & no Sb/Br)	CU NIPDAU	Level-1-260C-UNLIM
LM2902QN	OBSOLETE	PDIP	N	14		TBD	Call TI	Call TI
LM324AD	ACTIVE	SOIC	D	14	50	Green (RoHS & no Sb/Br)	CU NIPDAU	Level-1-260C-UNLIM
LM324ADBLE	OBSOLETE	SSOP	DB	14		TBD	Call TI	Call TI
LM324ADBR	ACTIVE	SSOP	DB	14	2000	Green (RoHS & no Sb/Br)	CU NIPDAU	Level-1-260C-UNLIM
LM324ADBRE4	ACTIVE	SSOP	DB	14	2000	Green (RoHS & no Sb/Br)	CU NIPDAU	Level-1-260C-UNLIM
LM324ADBRG4	ACTIVE	SSOP	DB	14	2000	Green (RoHS & no Sb/Br)	CU NIPDAU	Level-1-260C-UNLIM
LM324ADE4	ACTIVE	SOIC	D	14	50	Green (RoHS & no Sb/Br)	CU NIPDAU	Level-1-260C-UNLIM
LM324ADG4	ACTIVE	SOIC	D	14	50	Green (RoHS & no Sb/Br)	CU NIPDAU	Level-1-260C-UNLIM
LM324ADR	ACTIVE	SOIC	D	14	2500	Green (RoHS & no Sb/Br)	CU NIPDAU	Level-1-260C-UNLIM
LM324ADRE4	ACTIVE	SOIC	D	14	2500	Green (RoHS & no Sb/Br)	CU NIPDAU	Level-1-260C-UNLIM
LM324ADRG4	ACTIVE	SOIC	D	14	2500	Green (RoHS & no Sb/Br)	CU NIPDAU	Level-1-260C-UNLIM

Orderable Device	Status ⁽¹⁾	Package Type	Package Drawing	Pins	Package Qty	Eco Plan ⁽²⁾	Lead/Ball Finish	MSL Peak Temp ⁽³⁾
						no Sb/Br)		
LM324AN	ACTIVE	PDIP	N	14	25	Pb-Free (RoHS)	CU NIPDAU	N / A for Pkg Type
LM324ANE4	ACTIVE	PDIP	N	14	25	Pb-Free (RoHS)	CU NIPDAU	N / A for Pkg Type
LM324ANSR	ACTIVE	SO	NS	14	2000	Green (RoHS & no Sb/Br)	CU NIPDAU	Level-1-260C-UNLIM
LM324ANSRE4	ACTIVE	SO	NS	14	2000	Green (RoHS & no Sb/Br)	CU NIPDAU	Level-1-260C-UNLIM
LM324ANSRG4	ACTIVE	SO	NS	14	2000	Green (RoHS & no Sb/Br)	CU NIPDAU	Level-1-260C-UNLIM
LM324APW	ACTIVE	TSSOP	PW	14	90	Green (RoHS & no Sb/Br)	CU NIPDAU	Level-1-260C-UNLIM
LM324APWE4	ACTIVE	TSSOP	PW	14	90	Green (RoHS & no Sb/Br)	CU NIPDAU	Level-1-260C-UNLIM
LM324APWG4	ACTIVE	TSSOP	PW	14	90	Green (RoHS & no Sb/Br)	CU NIPDAU	Level-1-260C-UNLIM
LM324APWLE	OBSOLETE	TSSOP	PW	14		TBD	Call TI	Call TI
LM324APWR	ACTIVE	TSSOP	PW	14	2000	Green (RoHS & no Sb/Br)	CU NIPDAU	Level-1-260C-UNLIM
LM324APWRE4	ACTIVE	TSSOP	PW	14	2000	Green (RoHS & no Sb/Br)	CU NIPDAU	Level-1-260C-UNLIM
LM324APWRG4	ACTIVE	TSSOP	PW	14	2000	Green (RoHS & no Sb/Br)	CU NIPDAU	Level-1-260C-UNLIM
LM324D	ACTIVE	SOIC	D	14	50	Green (RoHS & no Sb/Br)	CU NIPDAU	Level-1-260C-UNLIM
LM324DE4	ACTIVE	SOIC	D	14	50	Green (RoHS & no Sb/Br)	CU NIPDAU	Level-1-260C-UNLIM
LM324DG4	ACTIVE	SOIC	D	14	50	Green (RoHS & no Sb/Br)	CU NIPDAU	Level-1-260C-UNLIM
LM324DR	ACTIVE	SOIC	D	14	2500	Green (RoHS & no Sb/Br)	CU NIPDAU	Level-1-260C-UNLIM
LM324DRE4	ACTIVE	SOIC	D	14	2500	Green (RoHS & no Sb/Br)	CU NIPDAU	Level-1-260C-UNLIM
LM324DRG4	ACTIVE	SOIC	D	14	2500	Green (RoHS & no Sb/Br)	CU NIPDAU	Level-1-260C-UNLIM
LM324KAD	ACTIVE	SOIC	D	14	50	Green (RoHS & no Sb/Br)	CU NIPDAU	Level-1-260C-UNLIM
LM324KADE4	ACTIVE	SOIC	D	14	50	Green (RoHS & no Sb/Br)	CU NIPDAU	Level-1-260C-UNLIM
LM324KADG4	ACTIVE	SOIC	D	14	50	Green (RoHS & no Sb/Br)	CU NIPDAU	Level-1-260C-UNLIM
LM324KADR	ACTIVE	SOIC	D	14	2500	Green (RoHS & no Sb/Br)	CU NIPDAU	Level-1-260C-UNLIM
LM324KADRE4	ACTIVE	SOIC	D	14	2500	Green (RoHS & no Sb/Br)	CU NIPDAU	Level-1-260C-UNLIM
LM324KADRG4	ACTIVE	SOIC	D	14	2500	Green (RoHS & no Sb/Br)	CU NIPDAU	Level-1-260C-UNLIM
LM324KAN	ACTIVE	PDIP	N	14	25	Pb-Free (RoHS)	CU NIPDAU	N / A for Pkg Type
LM324KANE4	ACTIVE	PDIP	N	14	25	Pb-Free	CU NIPDAU	N / A for Pkg Type

Orderable Device	Status ⁽¹⁾	Package Type	Package Drawing	Pins	Package Qty	Eco Plan ⁽²⁾	Lead/Ball Finish	MSL Peak Temp ⁽³⁾
						(RoHS)		
LM324KANS	PREVIEW	SO	NS	14	50	Green (RoHS & no Sb/Br)	CU NIPDAU	Level-1-260C-UNLIM
LM324KANSR	ACTIVE	SO	NS	14	2000	Green (RoHS & no Sb/Br)	CU NIPDAU	Level-1-260C-UNLIM
LM324KANSRE4	ACTIVE	SO	NS	14	2000	Green (RoHS & no Sb/Br)	CU NIPDAU	Level-1-260C-UNLIM
LM324KANSRG4	ACTIVE	SO	NS	14	2000	Green (RoHS & no Sb/Br)	CU NIPDAU	Level-1-260C-UNLIM
LM324KAPW	ACTIVE	TSSOP	PW	14	90	Green (RoHS & no Sb/Br)	CU NIPDAU	Level-1-260C-UNLIM
LM324KAPWE4	ACTIVE	TSSOP	PW	14	90	Green (RoHS & no Sb/Br)	CU NIPDAU	Level-1-260C-UNLIM
LM324KAPWG4	ACTIVE	TSSOP	PW	14	90	Green (RoHS & no Sb/Br)	CU NIPDAU	Level-1-260C-UNLIM
LM324KAPWR	ACTIVE	TSSOP	PW	14	2000	Green (RoHS & no Sb/Br)	CU NIPDAU	Level-1-260C-UNLIM
LM324KAPWRE4	ACTIVE	TSSOP	PW	14	2000	Green (RoHS & no Sb/Br)	CU NIPDAU	Level-1-260C-UNLIM
LM324KAPWRG4	ACTIVE	TSSOP	PW	14	2000	Green (RoHS & no Sb/Br)	CU NIPDAU	Level-1-260C-UNLIM
LM324KD	ACTIVE	SOIC	D	14	50	Green (RoHS & no Sb/Br)	CU NIPDAU	Level-1-260C-UNLIM
LM324KDE4	ACTIVE	SOIC	D	14	50	Green (RoHS & no Sb/Br)	CU NIPDAU	Level-1-260C-UNLIM
LM324KDG4	ACTIVE	SOIC	D	14	50	Green (RoHS & no Sb/Br)	CU NIPDAU	Level-1-260C-UNLIM
LM324KDR	ACTIVE	SOIC	D	14	2500	Green (RoHS & no Sb/Br)	CU NIPDAU	Level-1-260C-UNLIM
LM324KDRE4	ACTIVE	SOIC	D	14	2500	Green (RoHS & no Sb/Br)	CU NIPDAU	Level-1-260C-UNLIM
LM324KDRG4	ACTIVE	SOIC	D	14	2500	Green (RoHS & no Sb/Br)	CU NIPDAU	Level-1-260C-UNLIM
LM324KN	ACTIVE	PDIP	N	14	25	Pb-Free (RoHS)	CU NIPDAU	N / A for Pkg Type
LM324KNE4	ACTIVE	PDIP	N	14	25	Pb-Free (RoHS)	CU NIPDAU	N / A for Pkg Type
LM324KNS	PREVIEW	SO	NS	14	50	Green (RoHS & no Sb/Br)	CU NIPDAU	Level-1-260C-UNLIM
LM324KNSR	ACTIVE	SO	NS	14	2000	Green (RoHS & no Sb/Br)	CU NIPDAU	Level-1-260C-UNLIM
LM324KNSRE4	ACTIVE	SO	NS	14	2000	Green (RoHS & no Sb/Br)	CU NIPDAU	Level-1-260C-UNLIM
LM324KNSRG4	ACTIVE	SO	NS	14	2000	Green (RoHS & no Sb/Br)	CU NIPDAU	Level-1-260C-UNLIM
LM324KPW	ACTIVE	TSSOP	PW	14	90	Green (RoHS & no Sb/Br)	CU NIPDAU	Level-1-260C-UNLIM
LM324KPWE4	ACTIVE	TSSOP	PW	14	90	Green (RoHS & no Sb/Br)	CU NIPDAU	Level-1-260C-UNLIM
LM324KPWG4	ACTIVE	TSSOP	PW	14	90	Green (RoHS & no Sb/Br)	CU NIPDAU	Level-1-260C-UNLIM

Orderable Device	Status ⁽¹⁾	Package Type	Package Drawing	Pins	Package Qty	Eco Plan ⁽²⁾	Lead/Ball Finish	MSL Peak Temp ⁽³⁾
LM324KPWR	ACTIVE	TSSOP	PW	14	2000	Green (RoHS & no Sb/Br)	CU NIPDAU	Level-1-260C-UNLIM
LM324KPWRE4	ACTIVE	TSSOP	PW	14	2000	Green (RoHS & no Sb/Br)	CU NIPDAU	Level-1-260C-UNLIM
LM324KPWRG4	ACTIVE	TSSOP	PW	14	2000	Green (RoHS & no Sb/Br)	CU NIPDAU	Level-1-260C-UNLIM
LM324N	ACTIVE	PDIP	N	14	25	Pb-Free (RoHS)	CU NIPDAU	N / A for Pkg Type
LM324NE4	ACTIVE	PDIP	N	14	25	Pb-Free (RoHS)	CU NIPDAU	N / A for Pkg Type
LM324NSR	ACTIVE	SO	NS	14	2000	Green (RoHS & no Sb/Br)	CU NIPDAU	Level-1-260C-UNLIM
LM324NSRE4	ACTIVE	SO	NS	14	2000	Green (RoHS & no Sb/Br)	CU NIPDAU	Level-1-260C-UNLIM
LM324NSRG4	ACTIVE	SO	NS	14	2000	Green (RoHS & no Sb/Br)	CU NIPDAU	Level-1-260C-UNLIM
LM324PW	ACTIVE	TSSOP	PW	14	90	Green (RoHS & no Sb/Br)	CU NIPDAU	Level-1-260C-UNLIM
LM324PWE4	ACTIVE	TSSOP	PW	14	90	Green (RoHS & no Sb/Br)	CU NIPDAU	Level-1-260C-UNLIM
LM324PWG4	ACTIVE	TSSOP	PW	14	90	Green (RoHS & no Sb/Br)	CU NIPDAU	Level-1-260C-UNLIM
LM324PWLE	OBSOLETE	TSSOP	PW	14		TBD	Call TI	Call TI
LM324PWR	ACTIVE	TSSOP	PW	14	2000	Green (RoHS & no Sb/Br)	CU NIPDAU	Level-1-260C-UNLIM
LM324PWRE4	ACTIVE	TSSOP	PW	14	2000	Green (RoHS & no Sb/Br)	CU NIPDAU	Level-1-260C-UNLIM
LM324PWRG4	ACTIVE	TSSOP	PW	14	2000	Green (RoHS & no Sb/Br)	CU NIPDAU	Level-1-260C-UNLIM
LM324Y	OBSOLETE	DIESALE	Y	0		TBD	Call TI	Call TI

⁽¹⁾ The marketing status values are defined as follows:

ACTIVE: Product device recommended for new designs.

LIFEBUY: TI has announced that the device will be discontinued, and a lifetime-buy period is in effect.

NRND: Not recommended for new designs. Device is in production to support existing customers, but TI does not recommend using this part in a new design.

PREVIEW: Device has been announced but is not in production. Samples may or may not be available.

OBSOLETE: TI has discontinued the production of the device.

⁽²⁾ Eco Plan - The planned eco-friendly classification: Pb-Free (RoHS), Pb-Free (RoHS Exempt), or Green (RoHS & no Sb/Br) - please check <http://www.ti.com/productcontent> for the latest availability information and additional product content details.

TBD: The Pb-Free/Green conversion plan has not been defined.

Pb-Free (RoHS): TI's terms "Lead-Free" or "Pb-Free" mean semiconductor products that are compatible with the current RoHS requirements for all 6 substances, including the requirement that lead not exceed 0.1% by weight in homogeneous materials. Where designed to be soldered at high temperatures, TI Pb-Free products are suitable for use in specified lead-free processes.

Pb-Free (RoHS Exempt): This component has a RoHS exemption for either 1) lead-based flip-chip solder bumps used between the die and package, or 2) lead-based die adhesive used between the die and leadframe. The component is otherwise considered Pb-Free (RoHS compatible) as defined above.

Green (RoHS & no Sb/Br): TI defines "Green" to mean Pb-Free (RoHS compatible), and free of Bromine (Br) and Antimony (Sb) based flame retardants (Br or Sb do not exceed 0.1% by weight in homogeneous material)

⁽³⁾ MSL, Peak Temp. -- The Moisture Sensitivity Level rating according to the JEDEC industry standard classifications, and peak solder temperature.

Important Information and Disclaimer:The information provided on this page represents TI's knowledge and belief as of the date that it is provided. TI bases its knowledge and belief on information provided by third parties, and makes no representation or warranty as to the accuracy of such information. Efforts are underway to better integrate information from third parties. TI has taken and continues to take reasonable steps to provide representative and accurate information but may not have conducted destructive testing or chemical analysis on incoming materials and chemicals. TI and TI suppliers consider certain information to be proprietary, and thus CAS numbers and other limited information may not be available for release.

In no event shall TI's liability arising out of such information exceed the total purchase price of the TI part(s) at issue in this document sold by TI to Customer on an annual basis.

EEPW 电子產品世界
.com.cn

TAPE AND REEL BOX INFORMATION

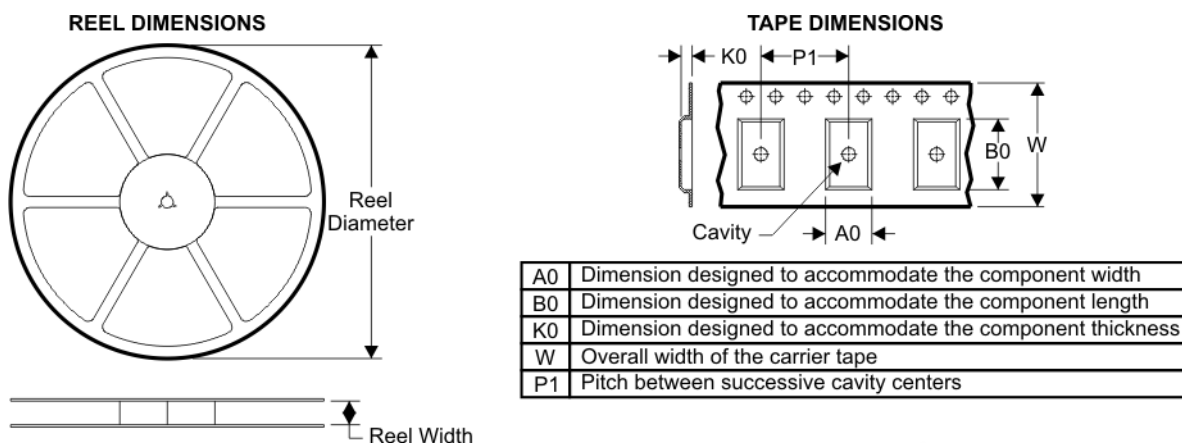

QUADRANT ASSIGNMENTS FOR PIN 1 ORIENTATION IN TAPE

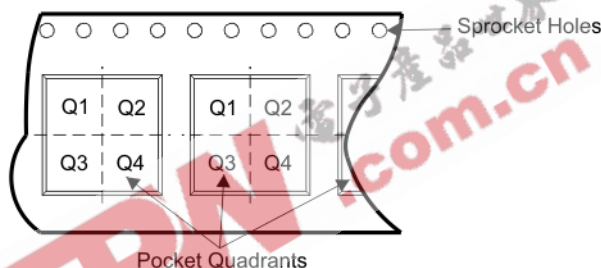

Device	Package	Pins	Site	Reel Diameter (mm)	Reel Width (mm)	A0 (mm)	B0 (mm)	K0 (mm)	P1 (mm)	W (mm)	Pin1 Quadrant
LM224ADR	D	14	SITE 41	330	16	6.5	9.0	2.1	8	16	Q1
LM224DR	D	14	SITE 41	330	16	6.5	9.0	2.1	8	16	Q1
LM224KADR	D	14	SITE 41	330	16	6.5	9.0	2.1	8	16	Q1
LM224KDR	D	14	SITE 41	330	16	6.5	9.0	2.1	8	16	Q1
LM2902DR	D	14	SITE 27	330	16	6.5	9.0	2.1	8	16	Q1
LM2902DR	D	14	SITE 41	330	16	6.5	9.0	2.1	8	16	Q1
LM2902KDBR	DB	14	SITE 41	330	16	8.2	6.6	2.5	12	16	Q1
LM2902KDR	D	14	SITE 41	330	16	6.5	9.0	2.1	8	16	Q1
LM2902KNSR	NS	14	SITE 41	330	16	8.2	10.5	2.5	12	16	Q1
LM2902KPWR	PW	14	SITE 41	330	12	7.0	5.6	1.6	8	12	Q1
LM2902NSR	NS	14	SITE 41	330	16	8.2	10.5	2.5	12	16	Q1
LM2902PWR	PW	14	SITE 41	330	12	7.0	5.6	1.6	8	12	Q1
LM324ADBR	DB	14	SITE 41	330	16	8.2	6.6	2.5	12	16	Q1
LM324ADR	D	14	SITE 41	330	16	6.5	9.0	2.1	8	16	Q1
LM324ANSR	NS	14	SITE 41	330	16	8.2	10.5	2.5	12	16	Q1
LM324APWR	PW	14	SITE 41	330	12	7.0	5.6	1.6	8	12	Q1
LM324DR	D	14	SITE 27	330	16	6.5	9.0	2.1	8	16	Q1
LM324DR	D	14	SITE 41	330	16	6.5	9.0	2.1	8	16	Q1
LM324KADR	D	14	SITE 41	330	16	6.5	9.0	2.1	8	16	Q1

Device	Package	Pins	Site	Reel Diameter (mm)	Reel Width (mm)	A0 (mm)	B0 (mm)	K0 (mm)	P1 (mm)	W (mm)	Pin1 Quadrant
LM324KANSR	NS	14	SITE 41	330	16	8.2	10.5	2.5	12	16	Q1
LM324KAPWR	PW	14	SITE 41	330	12	7.0	5.6	1.6	8	12	Q1
LM324KDR	D	14	SITE 41	330	16	6.5	9.0	2.1	8	16	Q1
LM324KNSR	NS	14	SITE 41	330	16	8.2	10.5	2.5	12	16	Q1
LM324KPWR	PW	14	SITE 41	330	12	7.0	5.6	1.6	8	12	Q1
LM324NSR	NS	14	SITE 41	330	16	8.2	10.5	2.5	12	16	Q1
LM324PWR	PW	14	SITE 41	330	12	7.0	5.6	1.6	8	12	Q1

TAPE AND REEL BOX DIMENSIONS

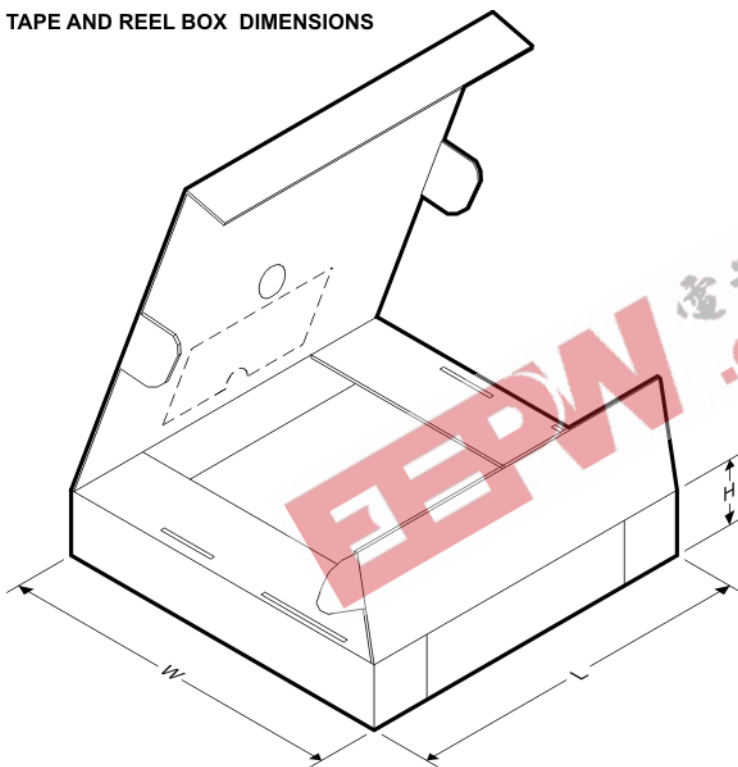

Device	Package	Pins	Site	Length (mm)	Width (mm)	Height (mm)
LM224ADR	D	14	SITE 41	346.0	346.0	33.0
LM224DR	D	14	SITE 41	346.0	346.0	33.0
LM224KADR	D	14	SITE 41	346.0	346.0	33.0
LM224KDR	D	14	SITE 41	346.0	346.0	33.0
LM2902DR	D	14	SITE 27	342.9	336.6	28.58
LM2902DR	D	14	SITE 41	346.0	346.0	33.0
LM2902KDBR	DB	14	SITE 41	346.0	346.0	33.0
LM2902KDR	D	14	SITE 41	346.0	346.0	33.0
LM2902KNSR	NS	14	SITE 41	346.0	346.0	33.0
LM2902KPWR	PW	14	SITE 41	346.0	346.0	29.0

Device	Package	Pins	Site	Length (mm)	Width (mm)	Height (mm)
LM2902NSR	NS	14	SITE 41	346.0	346.0	33.0
LM2902PWR	PW	14	SITE 41	346.0	346.0	29.0
LM324ADBR	DB	14	SITE 41	346.0	346.0	33.0
LM324ADR	D	14	SITE 41	346.0	346.0	33.0
LM324ANSR	NS	14	SITE 41	346.0	346.0	33.0
LM324APWR	PW	14	SITE 41	346.0	346.0	29.0
LM324DR	D	14	SITE 27	342.9	336.6	28.58
LM324DR	D	14	SITE 41	346.0	346.0	33.0
LM324KADR	D	14	SITE 41	346.0	346.0	33.0
LM324KANSR	NS	14	SITE 41	346.0	346.0	33.0
LM324KAPWR	PW	14	SITE 41	346.0	346.0	29.0
LM324KDR	D	14	SITE 41	346.0	346.0	33.0
LM324KNSR	NS	14	SITE 41	346.0	346.0	33.0
LM324KPWR	PW	14	SITE 41	346.0	346.0	29.0
LM324NSR	NS	14	SITE 41	346.0	346.0	33.0
LM324PWR	PW	14	SITE 41	346.0	346.0	29.0

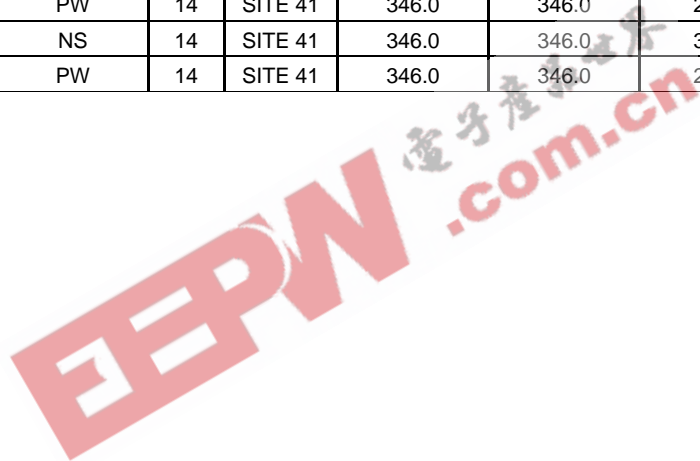

 电子产业网
 .com.cn

J (R-GDIP-T**)
14 LEADS SHOWN

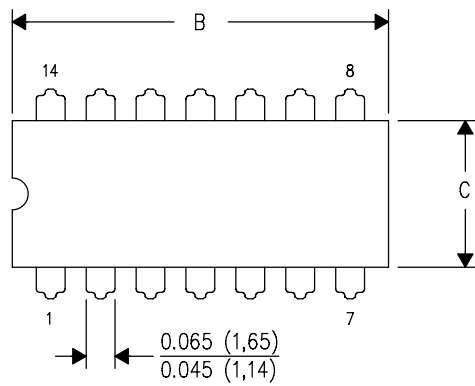
CERAMIC DUAL IN-LINE PACKAGE

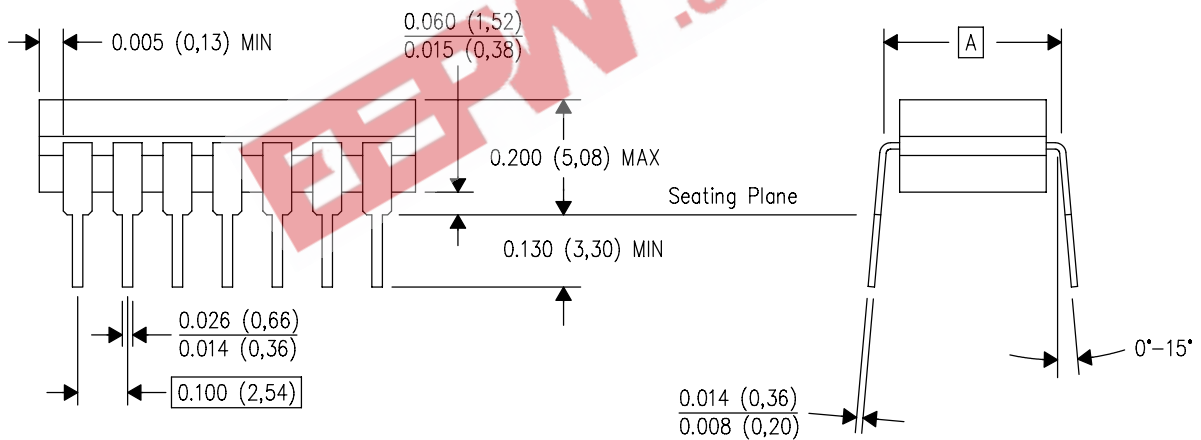

DIM \ PINS **	14	16	18	20
A	0.300 (7,62) BSC	0.300 (7,62) BSC	0.300 (7,62) BSC	0.300 (7,62) BSC
B MAX	0.785 (19,94)	.840 (21,34)	0.960 (24,38)	1.060 (26,92)
B MIN	—	—	—	—
C MAX	0.300 (7,62)	0.300 (7,62)	0.310 (7,87)	0.300 (7,62)
C MIN	0.245 (6,22)	0.245 (6,22)	0.220 (5,59)	0.245 (6,22)



4040083/F 03/03

- NOTES:
- All linear dimensions are in inches (millimeters).
 - This drawing is subject to change without notice.
 - This package is hermetically sealed with a ceramic lid using glass frit.
 - Index point is provided on cap for terminal identification only on press ceramic glass frit seal only.
 - Falls within MIL STD 1835 GDIP1-T14, GDIP1-T16, GDIP1-T18 and GDIP1-T20.

MECHANICAL DATA

W (R-GDFP-F14)

CERAMIC DUAL FLATPACK

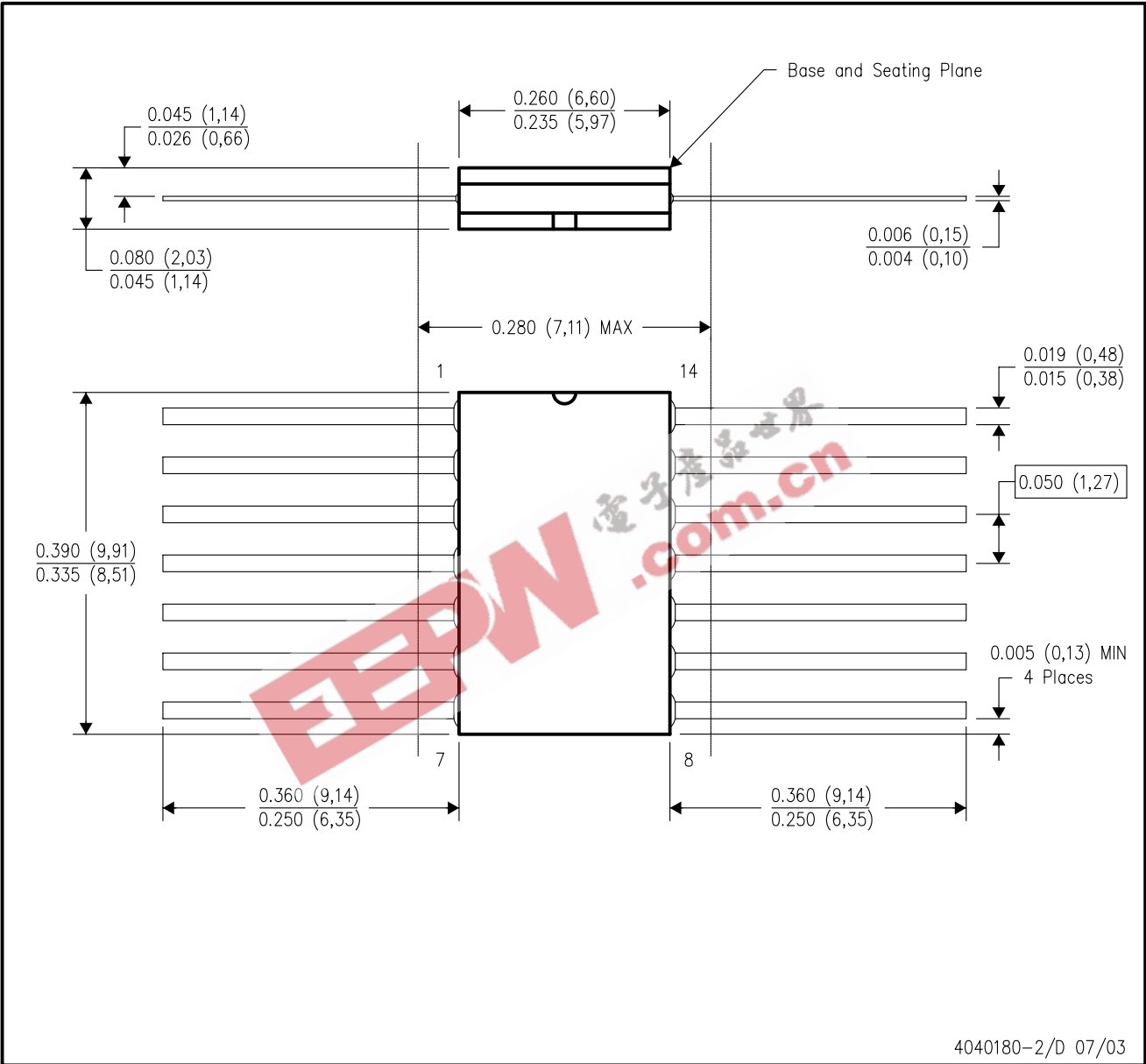

- NOTES:
- A. All linear dimensions are in inches (millimeters).
 - B. This drawing is subject to change without notice.
 - C. This package can be hermetically sealed with a ceramic lid using glass frit.
 - D. Index point is provided on cap for terminal identification only.
 - E. Falls within MIL STD 1835 GDFP1-F14 and JEDEC MO-092AB

FK (S-CQCC-N**)

LEADLESS CERAMIC CHIP CARRIER

28 TERMINAL SHOWN

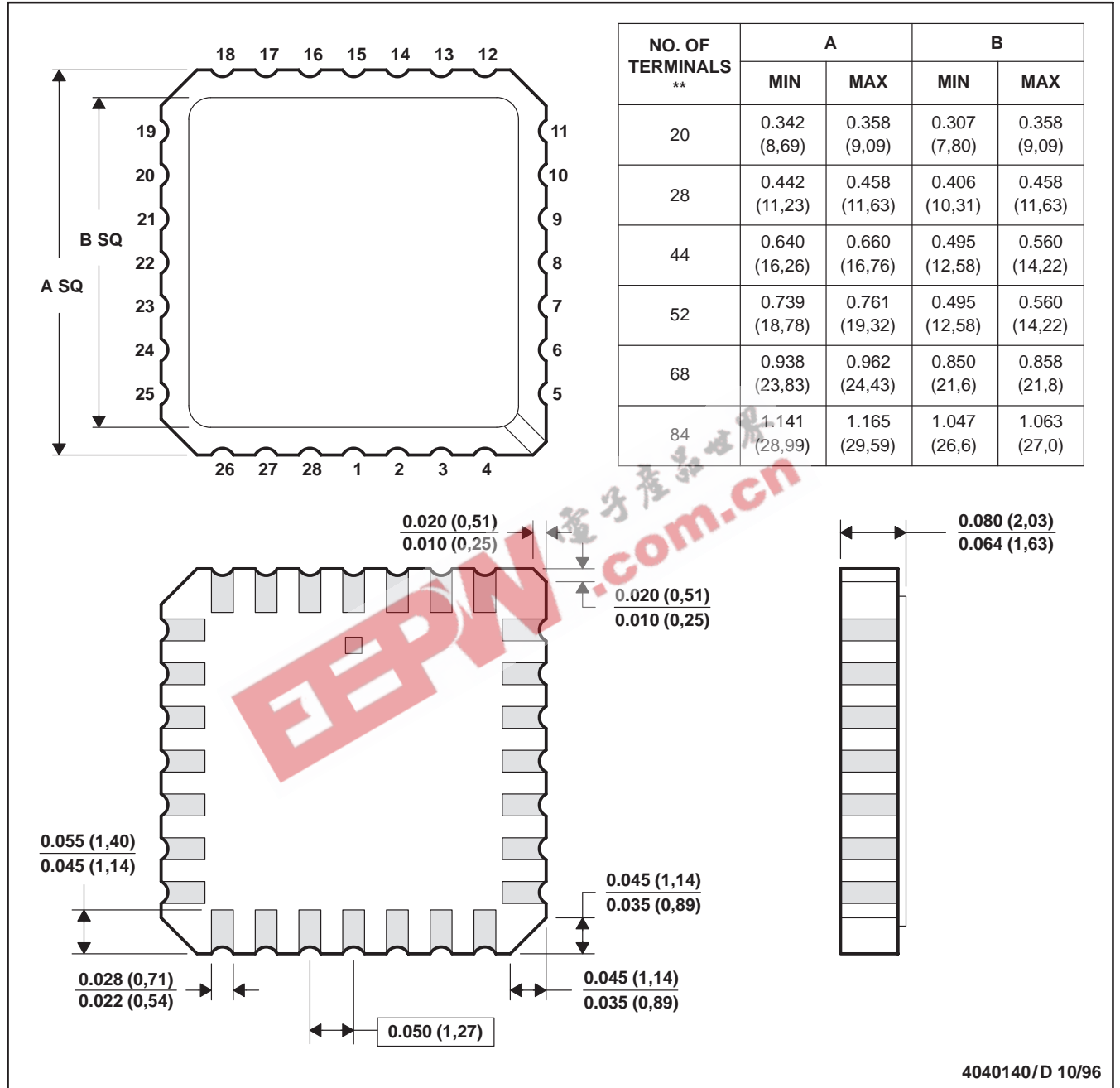

- NOTES:
- A. All linear dimensions are in inches (millimeters).
 - B. This drawing is subject to change without notice.
 - C. This package can be hermetically sealed with a metal lid.
 - D. The terminals are gold plated.
 - E. Falls within JEDEC MS-004

MECHANICAL DATA

N (R-PDIP-T**)

PLASTIC DUAL-IN-LINE PACKAGE

16 PINS SHOWN

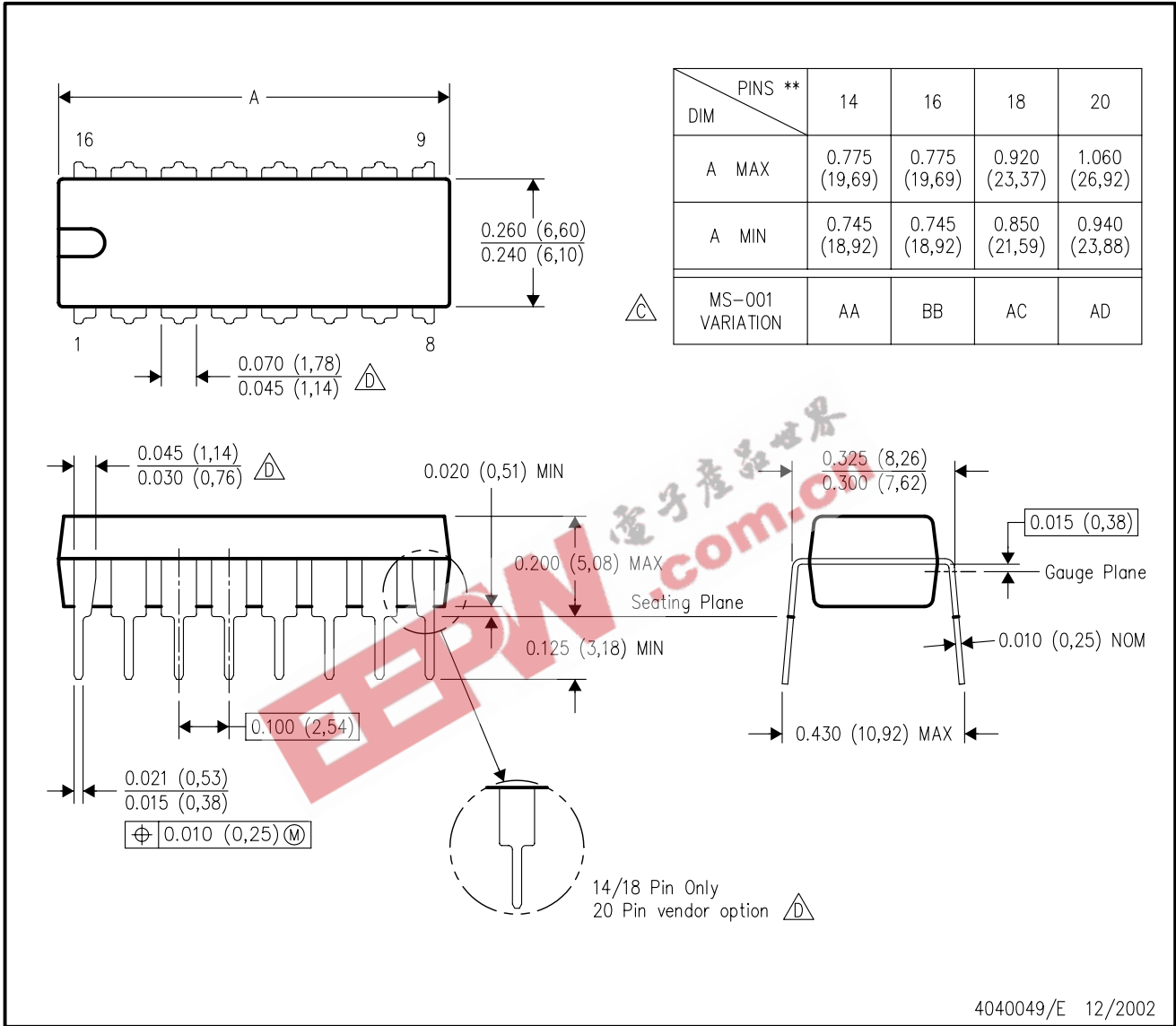

- NOTES:
- A. All linear dimensions are in inches (millimeters).
 - B. This drawing is subject to change without notice.
 - Falls within JEDEC MS-001, except 18 and 20 pin minimum body length (Dim A).
 - The 20 pin end lead shoulder width is a vendor option, either half or full width.

MECHANICAL DATA

D (R-PDSO-G14)

PLASTIC SMALL-OUTLINE PACKAGE

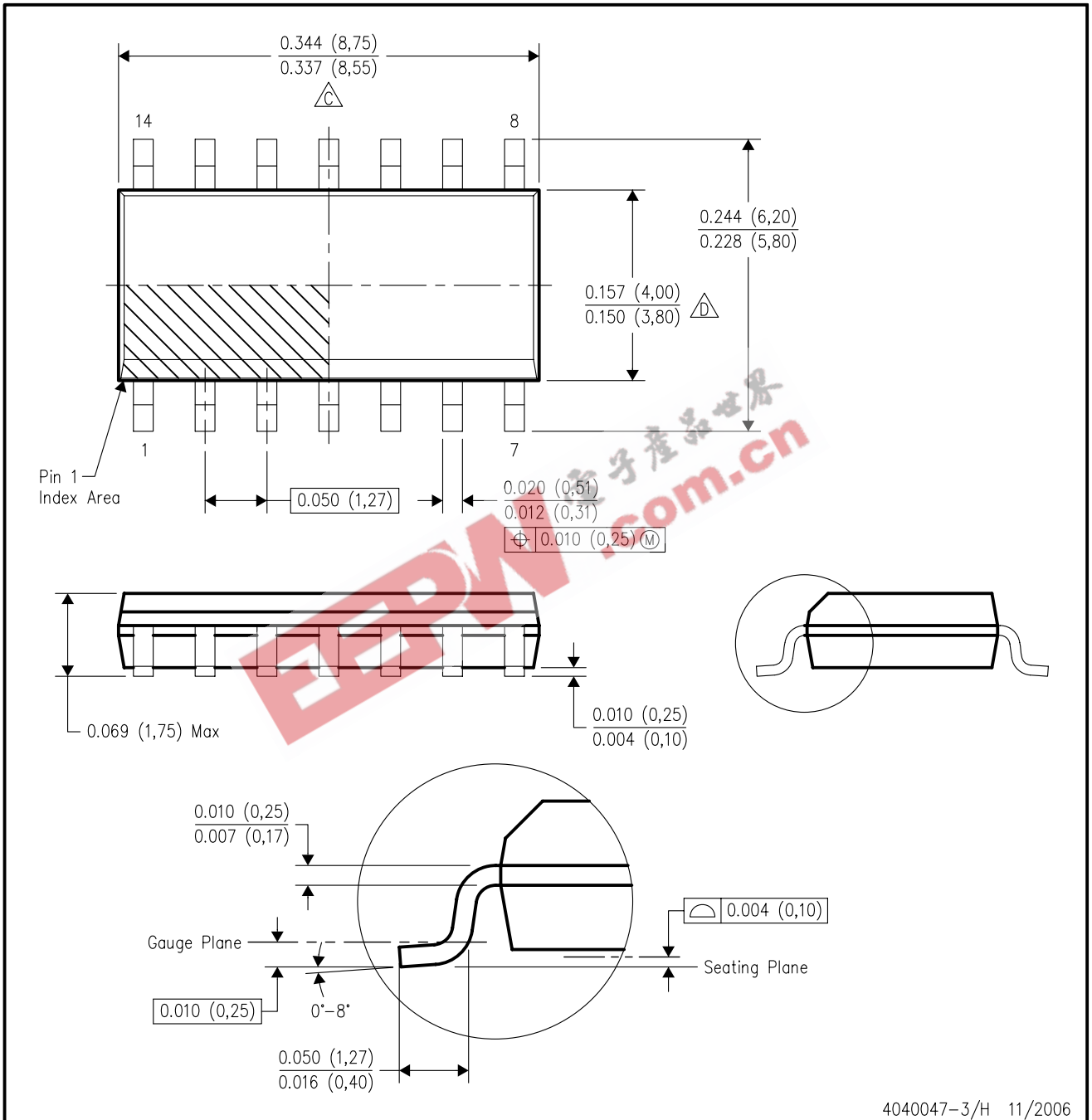

4040047-3/H 11/2006

- NOTES:
- All linear dimensions are in inches (millimeters).
 - This drawing is subject to change without notice.
 - Body length does not include mold flash, protrusions, or gate burrs. Mold flash, protrusions, or gate burrs shall not exceed .006 (0,15) per end.
 - Body width does not include interlead flash. Interlead flash shall not exceed .017 (0,43) per side.
 - Reference JEDEC MS-012 variation AB.

MECHANICAL DATA

NS (R-PDSO-G)**

PLASTIC SMALL-OUTLINE PACKAGE

14-PINS SHOWN

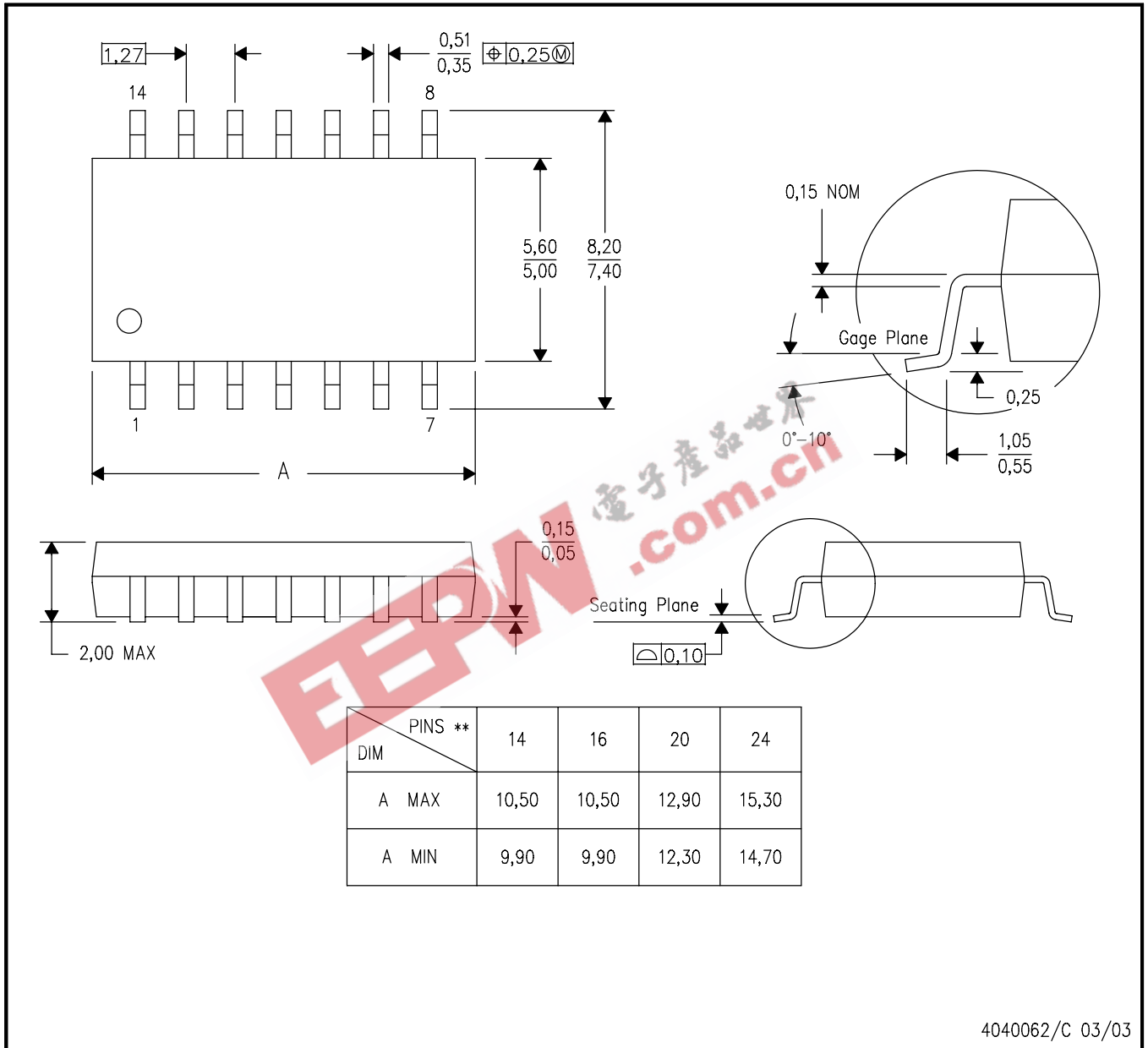

4040062/C 03/03

- NOTES:
- All linear dimensions are in millimeters.
 - This drawing is subject to change without notice.
 - Body dimensions do not include mold flash or protrusion, not to exceed 0,15.

MECHANICAL DATA

MSS0002E – JANUARY 1995 – REVISED DECEMBER 2001

DB (R-PDSO-G**)

PLASTIC SMALL-OUTLINE

28 PINS SHOWN

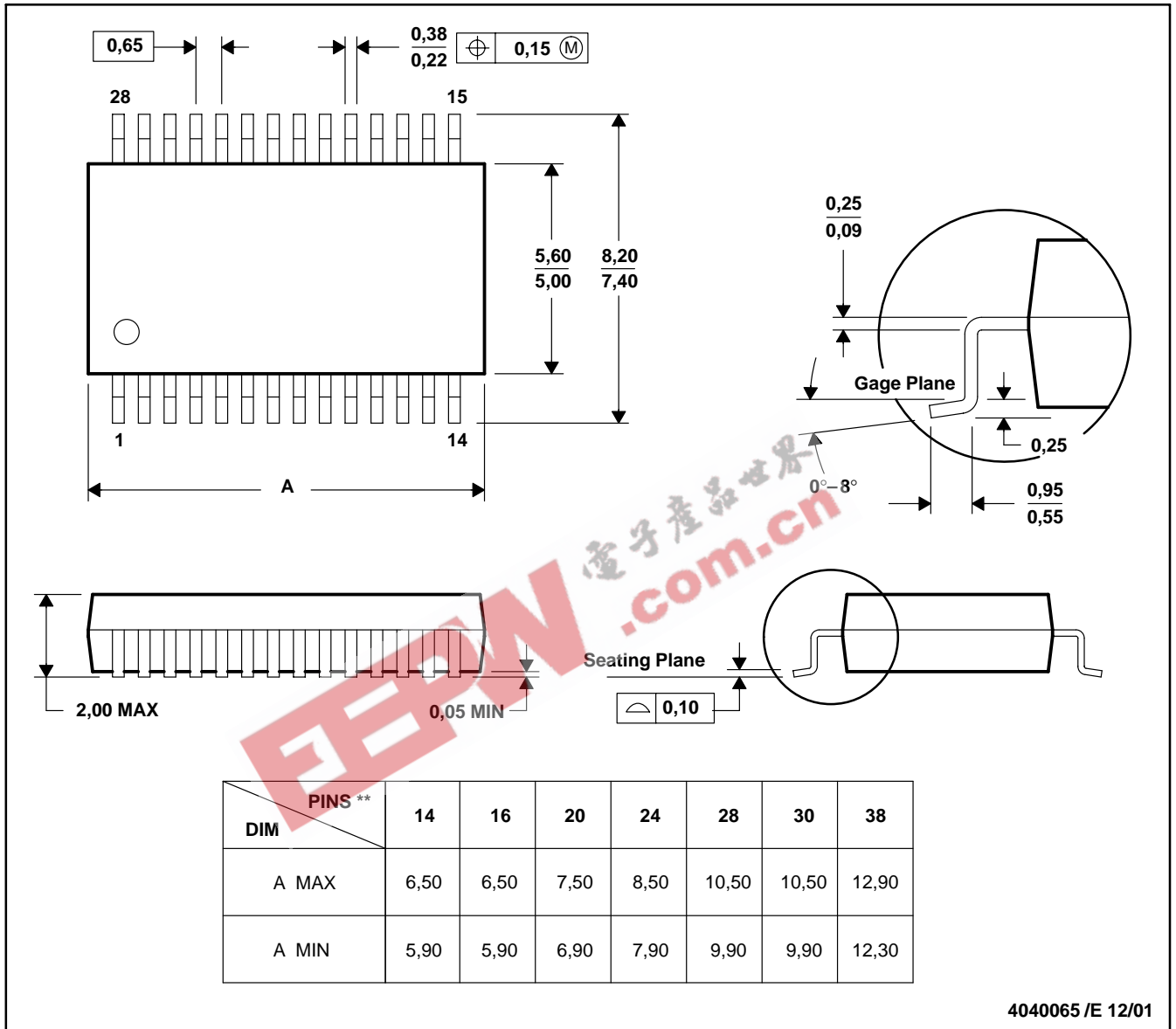

4040065 /E 12/01

- NOTES: A. All linear dimensions are in millimeters.
 B. This drawing is subject to change without notice.
 C. Body dimensions do not include mold flash or protrusion not to exceed 0,15.
 D. Falls within JEDEC MO-150

MECHANICAL DATA

MTSS001C – JANUARY 1995 – REVISED FEBRUARY 1999

PW (R-PDSO-G**)

PLASTIC SMALL-OUTLINE PACKAGE

14 PINS SHOWN

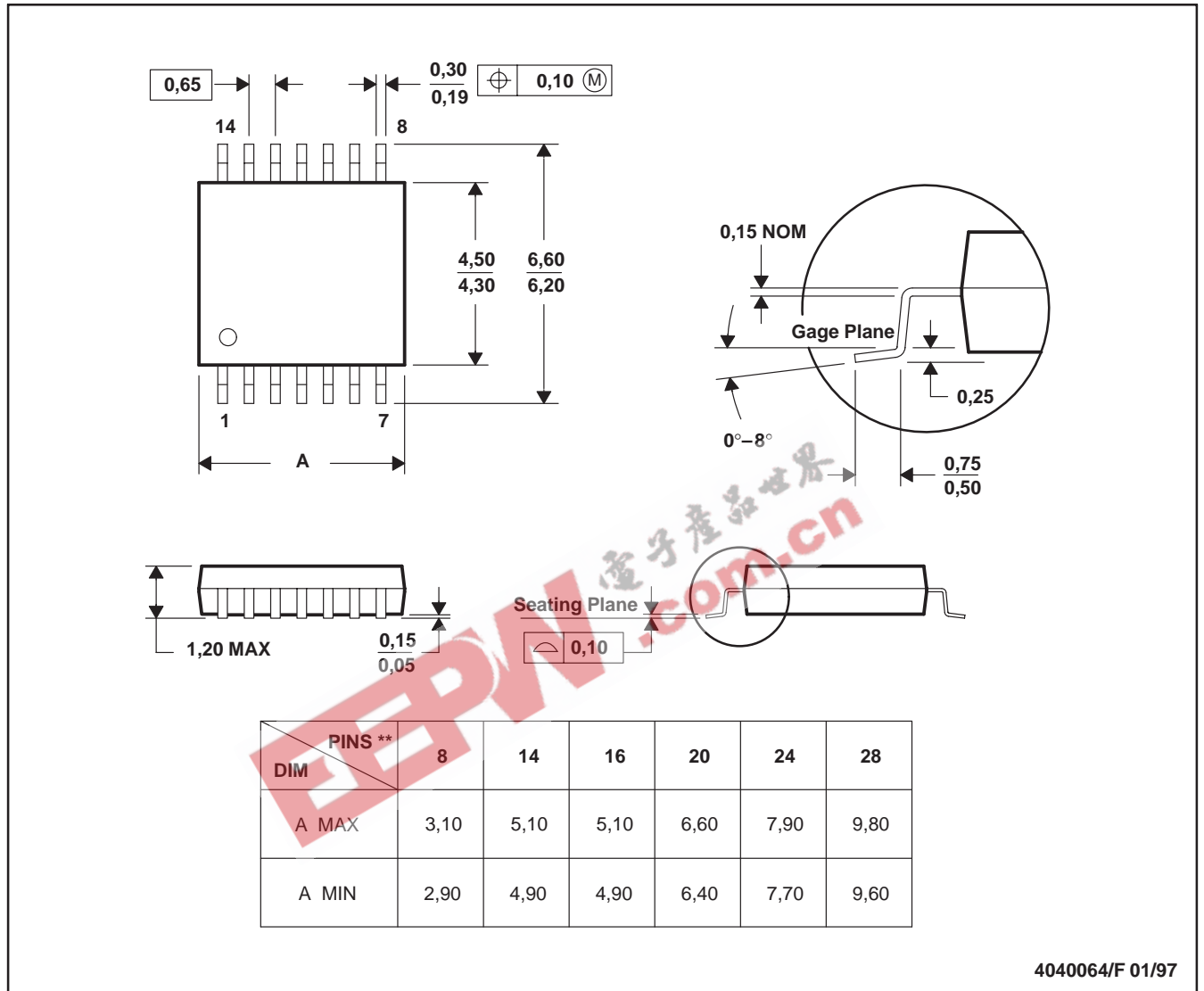

4040064/F 01/97

- NOTES: A. All linear dimensions are in millimeters.
 B. This drawing is subject to change without notice.
 C. Body dimensions do not include mold flash or protrusion not to exceed 0,15.
 D. Falls within JEDEC MO-153

IMPORTANT NOTICE

Texas Instruments Incorporated and its subsidiaries (TI) reserve the right to make corrections, modifications, enhancements, improvements, and other changes to its products and services at any time and to discontinue any product or service without notice. Customers should obtain the latest relevant information before placing orders and should verify that such information is current and complete. All products are sold subject to TI's terms and conditions of sale supplied at the time of order acknowledgment.

TI warrants performance of its hardware products to the specifications applicable at the time of sale in accordance with TI's standard warranty. Testing and other quality control techniques are used to the extent TI deems necessary to support this warranty. Except where mandated by government requirements, testing of all parameters of each product is not necessarily performed.

TI assumes no liability for applications assistance or customer product design. Customers are responsible for their products and applications using TI components. To minimize the risks associated with customer products and applications, customers should provide adequate design and operating safeguards.

TI does not warrant or represent that any license, either express or implied, is granted under any TI patent right, copyright, mask work right, or other TI intellectual property right relating to any combination, machine, or process in which TI products or services are used. Information published by TI regarding third-party products or services does not constitute a license from TI to use such products or services or a warranty or endorsement thereof. Use of such information may require a license from a third party under the patents or other intellectual property of the third party, or a license from TI under the patents or other intellectual property of TI.

Reproduction of TI information in TI data books or data sheets is permissible only if reproduction is without alteration and is accompanied by all associated warranties, conditions, limitations, and notices. Reproduction of this information with alteration is an unfair and deceptive business practice. TI is not responsible or liable for such altered documentation. Information of third parties may be subject to additional restrictions.

Resale of TI products or services with statements different from or beyond the parameters stated by TI for that product or service voids all express and any implied warranties for the associated TI product or service and is an unfair and deceptive business practice. TI is not responsible or liable for any such statements.

TI products are not authorized for use in safety-critical applications (such as life support) where a failure of the TI product would reasonably be expected to cause severe personal injury or death, unless officers of the parties have executed an agreement specifically governing such use. Buyers represent that they have all necessary expertise in the safety and regulatory ramifications of their applications, and acknowledge and agree that they are solely responsible for all legal, regulatory and safety-related requirements concerning their products and any use of TI products in such safety-critical applications, notwithstanding any applications-related information or support that may be provided by TI. Further, Buyers must fully indemnify TI and its representatives against any damages arising out of the use of TI products in such safety-critical applications.

TI products are neither designed nor intended for use in military/aerospace applications or environments unless the TI products are specifically designated by TI as military-grade or "enhanced plastic." Only products designated by TI as military-grade meet military specifications. Buyers acknowledge and agree that any such use of TI products which TI has not designated as military-grade is solely at the Buyer's risk, and that they are solely responsible for compliance with all legal and regulatory requirements in connection with such use.

TI products are neither designed nor intended for use in automotive applications or environments unless the specific TI products are designated by TI as compliant with ISO/TS 16949 requirements. Buyers acknowledge and agree that, if they use any non-designated products in automotive applications, TI will not be responsible for any failure to meet such requirements.

Following are URLs where you can obtain information on other Texas Instruments products and application solutions:

Products		Applications	
Amplifiers	amplifier.ti.com	Audio	www.ti.com/audio
Data Converters	dataconverter.ti.com	Automotive	www.ti.com/automotive
DSP	dsp.ti.com	Broadband	www.ti.com/broadband
Interface	interface.ti.com	Digital Control	www.ti.com/digitalcontrol
Logic	logic.ti.com	Military	www.ti.com/military
Power Mgmt	power.ti.com	Optical Networking	www.ti.com/opticalnetwork
Microcontrollers	microcontroller.ti.com	Security	www.ti.com/security
RFID	www.ti-rfid.com	Telephony	www.ti.com/telephony
Low Power Wireless	www.ti.com/lpw	Video & Imaging	www.ti.com/video
		Wireless	www.ti.com/wireless

Mailing Address: Texas Instruments, Post Office Box 655303, Dallas, Texas 75265
Copyright © 2007, Texas Instruments Incorporated