

LM567/LM567C Tone Decoder

General Description

The LM567 and LM567C are general purpose tone decoders designed to provide a saturated transistor switch to ground when an input signal is present within the passband. The circuit consists of an I and Q detector driven by a voltage controlled oscillator which determines the center frequency of the decoder. External components are used to independently set center frequency, bandwidth and output delay.

Features

- 20 to 1 frequency range with an external resistor
- Logic compatible output with 100 mA current sinking capability
- Bandwidth adjustable from 0 to 14%

- High rejection of out of band signals and noise
- Immunity to false signals
- Highly stable center frequency
- Center frequency adjustable from 0.01 Hz to 500 kHz

Applications

- Touch tone decoding
- Precision oscillator
- Frequency monitoring and control
- Wide band FSK demodulation
- Ultrasonic controls
- Carrier current remote controls
- Communications paging decoders

Connection Diagrams

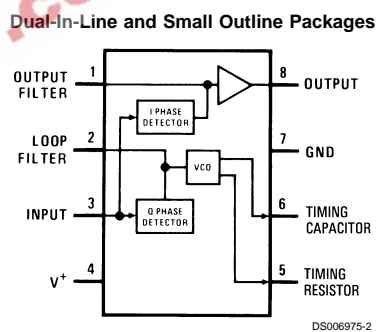
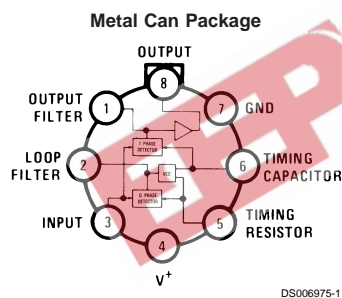

Absolute Maximum Ratings (Note 1)

If Military/Aerospace specified devices are required, please contact the National Semiconductor Sales Office/Distributors for availability and specifications.

Supply Voltage Pin	9V
Power Dissipation (Note 2)	1100 mW
V_8	15V
V_3	-10V
V_3	$V_4 + 0.5V$
Storage Temperature Range	-65°C to +150°C

Operating Temperature Range

LM567H	-55°C to +125°C
LM567CH, LM567CM, LM567CN	0°C to +70°C

Soldering Information

Dual-In-Line Package	
Soldering (10 sec.)	260°C
Small Outline Package	
Vapor Phase (60 sec.)	215°C
Infrared (15 sec.)	220°C

See AN-450 "Surface Mounting Methods and Their Effect on Product Reliability" for other methods of soldering surface mount devices.

Electrical Characteristics

AC Test Circuit, $T_A = 25^\circ\text{C}$, $V^+ = 5V$

Parameters	Conditions	LM567			LM567C/LM567CM			Units
		Min	Typ	Max	Min	Typ	Max	
Power Supply Voltage Range		4.75	5.0	9.0	4.75	5.0	9.0	V
Power Supply Current Quiescent	$R_L = 20k$		6	8		7	10	mA
Power Supply Current Activated	$R_L = 20k$		11	13		12	15	mA
Input Resistance		18	20		15	20		k Ω
Smallest Detectable Input Voltage	$I_L = 100\text{ mA}$, $f_i = f_o$		20	25		20	25	mVrms
Largest No Output Input Voltage	$I_C = 100\text{ mA}$, $f_i = f_o$	10	15		10	15		mVrms
Largest Simultaneous Outband Signal to Inband Signal Ratio			6			6		dB
Minimum Input Signal to Wideband Noise Ratio	$B_n = 140\text{ kHz}$		-6			-6		dB
Largest Detection Bandwidth		12	14	16	10	14	18	% of f_o
Largest Detection Bandwidth Skew			1	2		2	3	% of f_o
Largest Detection Bandwidth Variation with Temperature			± 0.1			± 0.1		%/°C
Largest Detection Bandwidth Variation with Supply Voltage	4.75-6.75V		± 1	± 2		± 1	± 5	%/V
Highest Center Frequency		100	500		100	500		kHz
Center Frequency Stability (4.75-5.75V)	$0 < T_A < 70$ $-55 < T_A < +125$		35 ± 60 35 ± 140			35 ± 60 35 ± 140		ppm/°C ppm/°C
Center Frequency Shift with Supply Voltage	4.75V-6.75V 4.75V-9V		0.5	1.0 2.0		0.4	2.0 2.0	%/V %/V
Fastest ON-OFF Cycling Rate			$f_o/20$			$f_o/20$		
Output Leakage Current	$V_8 = 15V$		0.01	25		0.01	25	μA
Output Saturation Voltage	$e_i = 25\text{ mV}$, $I_B = 30\text{ mA}$ $e_i = 25\text{ mV}$, $I_B = 100\text{ mA}$		0.2 0.6	0.4 1.0		0.2 0.6	0.4 1.0	V
Output Fall Time			30			30		ns
Output Rise Time			150			150		ns

Note 1: Absolute Maximum Ratings indicate limits beyond which damage to the device may occur. Operating Ratings indicate conditions for which the device is functional, but do not guarantee specific performance limits. Electrical Characteristics state DC and AC electrical specifications under particular test conditions which guarantee specific performance limits. This assumes that the device is within the Operating Ratings. Specifications are not guaranteed for parameters where no limit is given, however, the typical value is a good indication of device performance.

Note 2: The maximum junction temperature of the LM567 and LM567C is 150°C. For operating at elevated temperatures, devices in the TO-5 package must be derated based on a thermal resistance of 150°C/W, junction to ambient or 45°C/W, junction to case. For the DIP the device must be derated based on a thermal resistance of 110°C/W, junction to ambient. For the Small Outline package, the device must be derated based on a thermal resistance of 160°C/W, junction to ambient.

Note 3: Refer to RETS567X drawing for specifications of military LM567H version.

Schematic Diagram

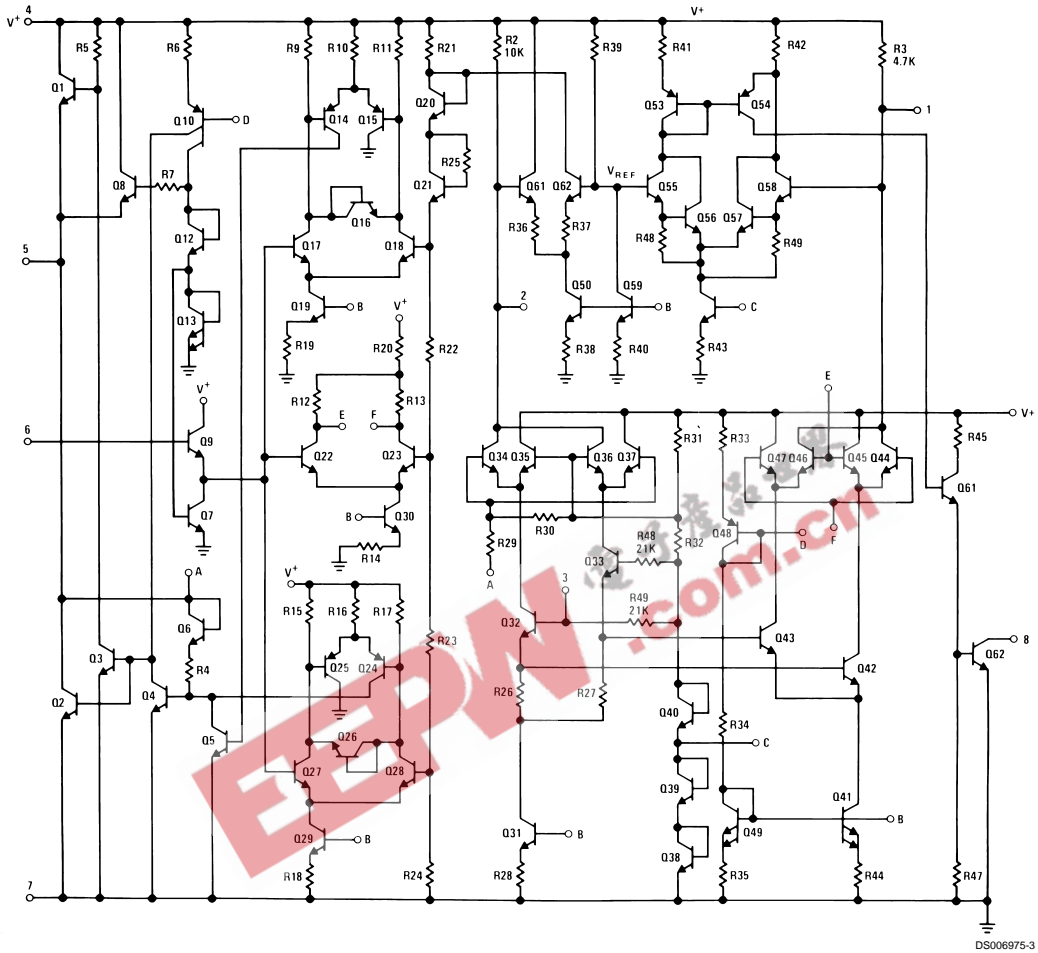

Typical Performance Characteristics

Typical Frequency Drift

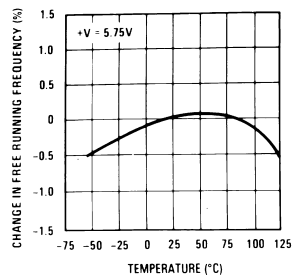

DS006975-10

Typical Bandwidth Variation

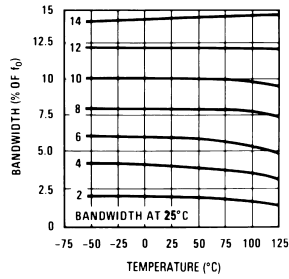

DS006975-11

Typical Frequency Drift

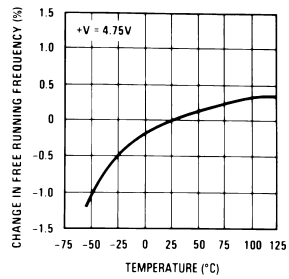

DS006975-12

Typical Performance Characteristics (Continued)

Typical Frequency Drift

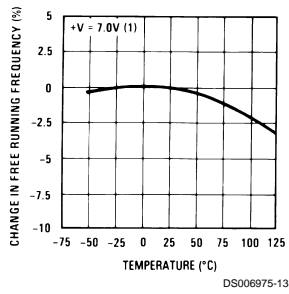

Bandwidth vs Input Signal Amplitude

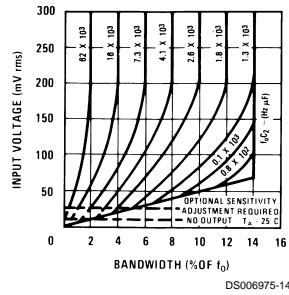

Largest Detection Bandwidth

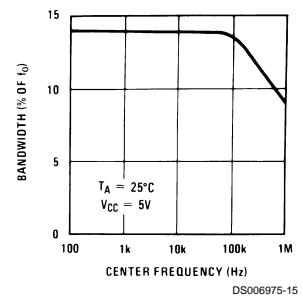

Detection Bandwidth as a Function of C_2 and C_3

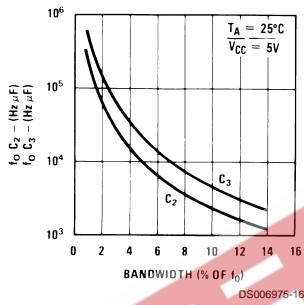

Typical Supply Current vs Supply Voltage

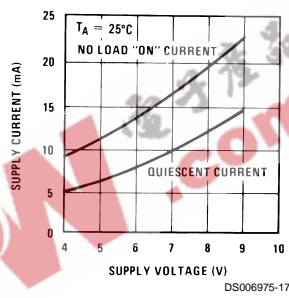

Greatest Number of Cycles Before Output

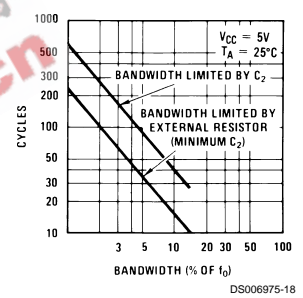

Typical Output Voltage vs Temperature

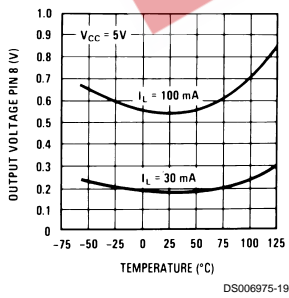

Typical Applications

Touch-Tone Decoder

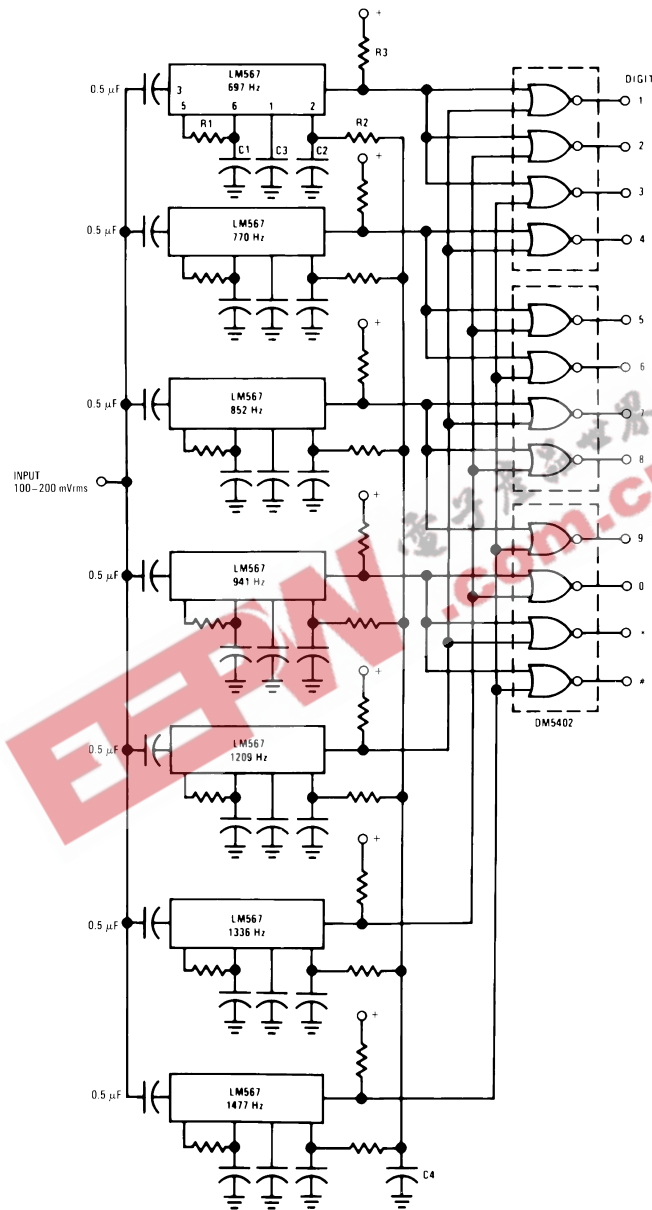

Component values (typ)

- R1 6.8 to 15k
- R2 4.7k
- R3 20k
- C1 0.10 mfd
- C2 1.0 mfd 6V
- C3 2.2 mfd 6V
- C4 250 mfd 6V

DS006975-5

Typical Applications (Continued)

Oscillator with Quadrature Output

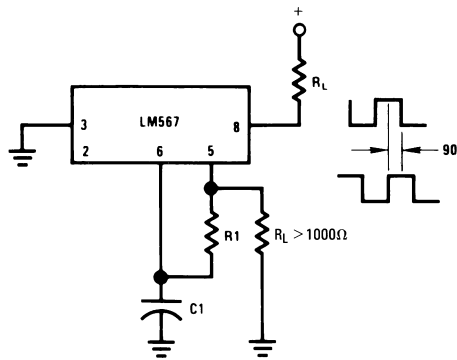

DS006975-6

Oscillator with Double Frequency Output

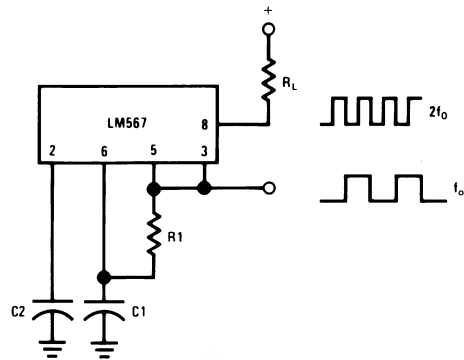

DS006975-7

Connect Pin 3 to 2.8V to Invert Output

Precision Oscillator Drive 100 mA Loads

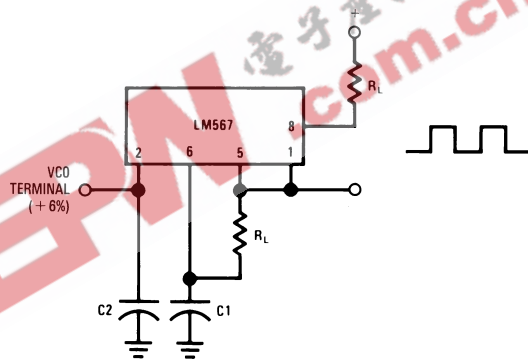

DS006975-8

AC Test Circuit

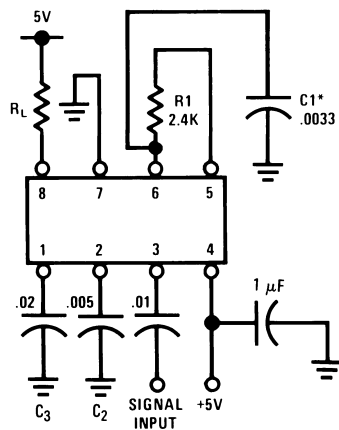

DS006975-9

$f_i = 100 \text{ kHz} + 5V$

*Note: Adjust for $f_o = 100 \text{ kHz}$.

Applications Information

The center frequency of the tone decoder is equal to the free running frequency of the VCO. This is given by

$$f_o \cong \frac{1}{1.1 R_1 C_1}$$

The bandwidth of the filter may be found from the approximation

$$BW = 1070 \sqrt{\frac{V_i}{f_o C_2}} \text{ in } \% \text{ of } f_o$$

Where:

V_i = Input voltage (volts rms), $V_i \leq 200 \text{ mV}$

C_2 = Capacitance at Pin 2 (μF)

Physical Dimensions inches (millimeters) unless otherwise noted

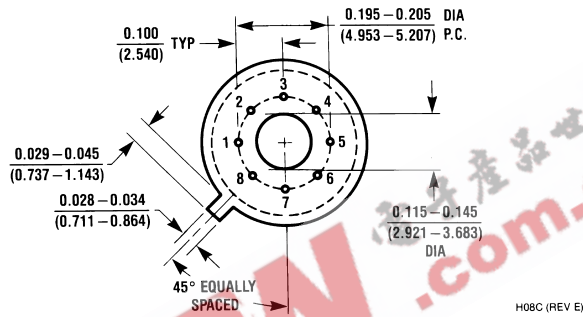
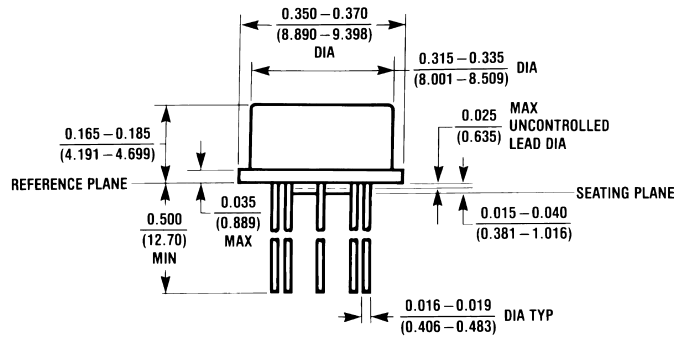

Metal Can Package (H)
 Order Number LM567H or LM567CH
 NS Package Number H08C

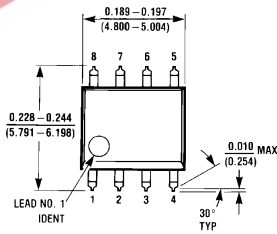

Small Outline Package (M)
 Order Number LM567CM
 NS Package Number M08A

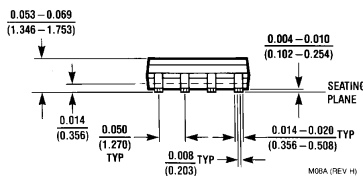
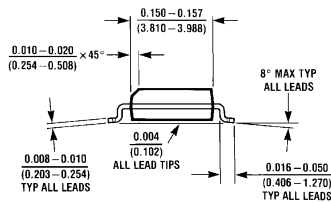

Physical Dimensions inches (millimeters) unless otherwise noted (Continued)

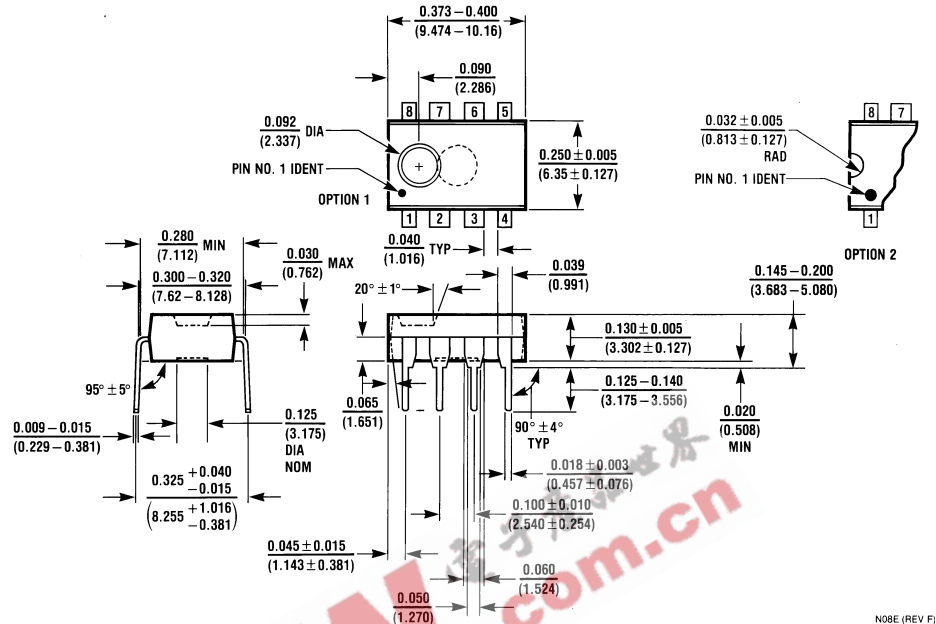

Molded Dual-In-Line Package (N)
 Order Number LM567CN
 NS Package Number N08E

N08E (REV F)

LIFE SUPPORT POLICY

NATIONAL'S PRODUCTS ARE NOT AUTHORIZED FOR USE AS CRITICAL COMPONENTS IN LIFE SUPPORT DEVICES OR SYSTEMS WITHOUT THE EXPRESS WRITTEN APPROVAL OF THE PRESIDENT AND GENERAL COUNSEL OF NATIONAL SEMICONDUCTOR CORPORATION. As used herein:

1. Life support devices or systems are devices or systems which, (a) are intended for surgical implant into the body, or (b) support or sustain life, and whose failure to perform when properly used in accordance with instructions for use provided in the labeling, can be reasonably expected to result in a significant injury to the user.
2. A critical component is any component of a life support device or system whose failure to perform can be reasonably expected to cause the failure of the life support device or system, or to affect its safety or effectiveness.



National Semiconductor Corporation
 Americas
 Tel: 1-800-272-9959
 Fax: 1-800-737-7018
 Email: support@nsc.com

www.national.com

National Semiconductor Europe
 Fax: +49 (0) 1 80-530 85 86
 Email: europe.support@nsc.com
 Deutsch Tel: +49 (0) 1 80-530 85 85
 English Tel: +49 (0) 1 80-532 78 32
 Français Tel: +49 (0) 1 80-532 93 58
 Italiano Tel: +49 (0) 1 80-534 16 80

National Semiconductor Asia Pacific Customer Response Group
 Tel: 65-2544466
 Fax: 65-2504466
 Email: sea.support@nsc.com

National Semiconductor Japan Ltd.
 Tel: 81-3-5639-7560
 Fax: 81-3-5639-7507