

SPECIFICATIONS

MODEL	Infrared LAMP LED
PART NO.	LI520C

[Contents]

1.	Devices -----	1
2.	Outline Dimensions -----	1
3.	Absolute Maximum Ratings -----	2
4.	Electro-Optical Characteristics -----	3
5.	Reliability Tests -----	4
6.	Characteristic Diagrams -----	5
7.	Bin Code Description -----	6
8.	Packing -----	7
9.	Soldering Profile -----	10
10.	Reference -----	11
11.	Precaution For Use -----	12

1. Devices

Part Number	Lens		Source	
	Color	Diffusion	Dice Source	Color
LI520C	Blue -Risen	Non-Diffused	GaAlAs/GaAs	Infrared

2. Outline Dimensions

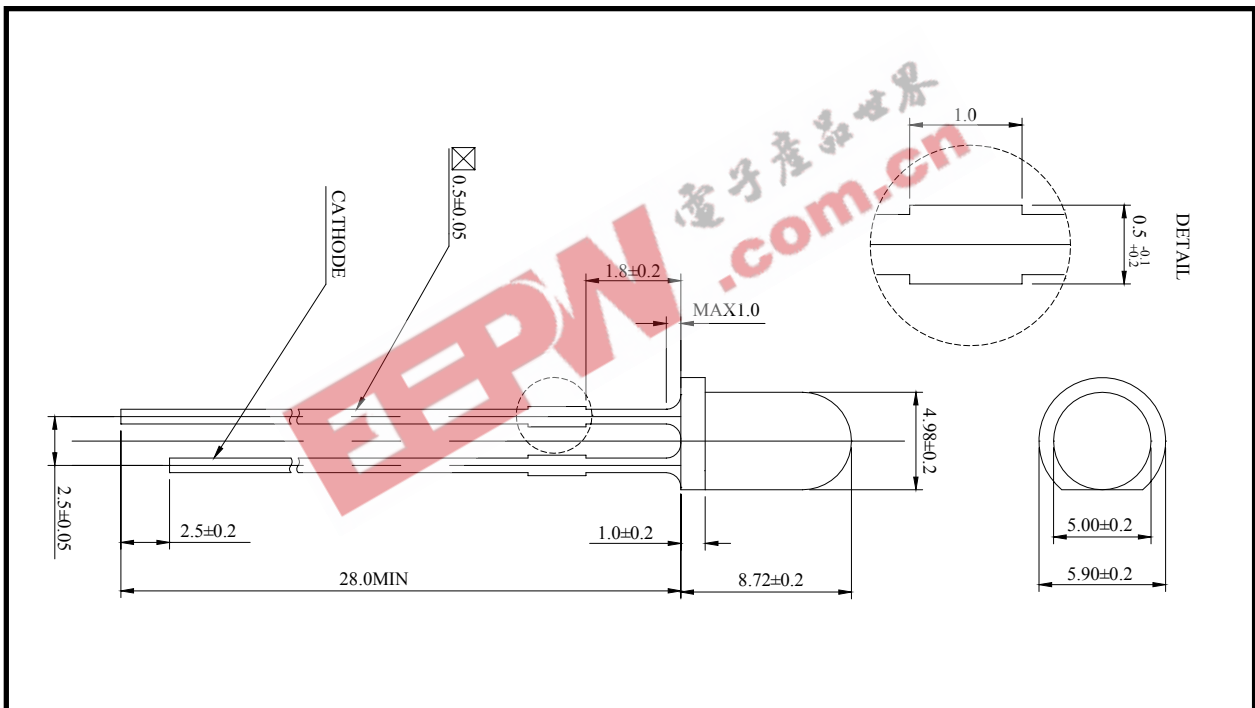

- Notes : 1. All dimensions are in millimeters.
 2. Protruded epoxy is 1.0mm maximum.



3. Absolute Maximum Ratings (at $T_a = 25^\circ\text{C}$)

Item	Symbol	Value	Unit
DC Forward Current	I_F	100	mA
Forward Peak Pulse Current	I_{FM}^{*1}	1000	mA
Reverse Voltage	V_R	5	V
Power Dissipation	P_D	150	mW
Operating Temperature	T_{opr}	-20 ~ +80	$^\circ\text{C}$
Storage Temperature	T_{stg}	-30 ~ +100	$^\circ\text{C}$
Solder Temperature	T_S	260 $^\circ\text{C}$ for 5 second ^{*2}	$^\circ\text{C}$

Notes : *1. $t \leq 0.01\text{ms}$, $D = 1/100$

*2. 3mm bellow seating plane



4. Electro-Optical Characteristics (at $I_F = 100\text{mA}$, $T_a = 25^\circ\text{C}$)

Item	Symbol	Value			Unit
		Min.	Typ.	Max.	
Radiant Intensity	I_e	30	65	130	mW/sr
Peak Wavelength	λ_p	-	940	-	nm
Spectrum Radiation Bandwidth	$\Delta\lambda$	-	50	-	nm
Forward Voltage	V_F	-	1.2	1.55	V
View Angle	$2\theta_{1/2}$	24			deg.
Reverse Current (at $V_R = 5\text{V}$)	I_R	10			μA

Note : 1. Radiant Intensity Tolerance $\pm 10\%$



5. RELIABILITY TESTS

Item	Condition	Note	Failures
Life Test	$T_a = RT, I_F = 100mA$	1000 hrs	0/22
High Temperature Operating	$T_a = 85^{\circ}C, I_F = 25mA$	1000 hrs	0/22
Low Temperature Operating	$T_a = -40^{\circ}C, I_F = 100mA$	1000 hrs	0/22
Thermal Shock	$T_a = -30^{\circ}C \sim +100^{\circ}$ (Transfer time : 5sec , 1 Cycle =1hr)	100 cycles	0/22
Temperature Cycle	$T_a = -20^{\circ}C \sim +80^{\circ}C$ (Transfer time : 5min , 1 Cycle =1hr)	100 cycles	0/22
Resistance to soldering Heat	$T_s = 260 \pm 5^{\circ}C, t = 10 \pm 1 \text{ sec}$	1 time	0/22
ESD (Human Body Model)	1 kV, 1.5 k Ω ; 100 pF	1 time	0/22
High Temperature Storage	$T_a = 100^{\circ}C$	1000 hrs	0/22
Low Temperature Storage	$T_a = -30^{\circ}C$	1000 hrs	0/22
Temperature Humidity Storage	$T_a = +85^{\circ}C, RH=85\%$	1000hrs	0/22
Temperature Humidity Operating	$T_a = +85^{\circ}C, RH=85\%$ $I_F = 25mA$	100hrs	0/22

< Judging Criteria For Reliability Tests >

V _F	USL ¹ X 1.2
I _R	USL X 2.0
I _V	LSL ² X 0.5

Notes : 1.USL : Upper Standard Level 2.LSL : Lower Standard Level.



6. Characteristic Diagrams

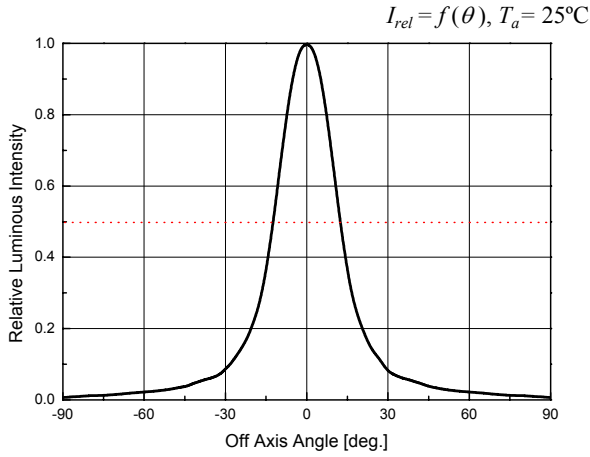

Off Axis Angle vs. Relative Radiant Intensity

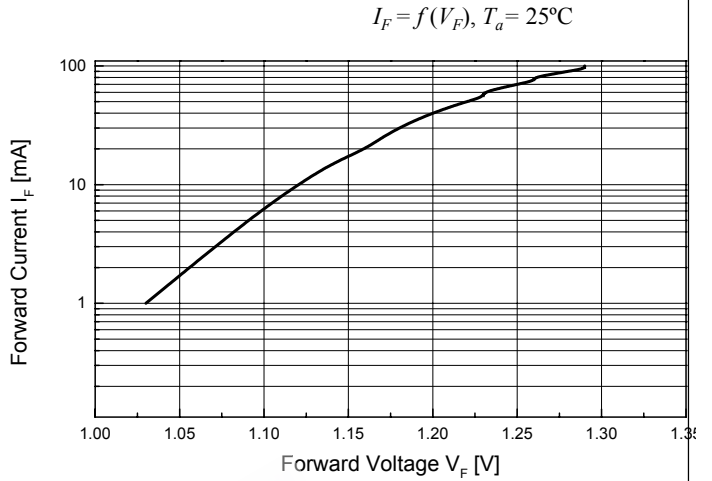

Forward Voltage vs. Forward Current

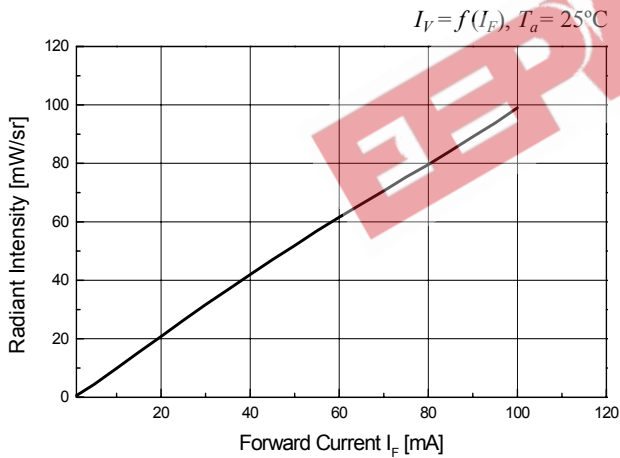

Forward Current vs. Radiant Intensity

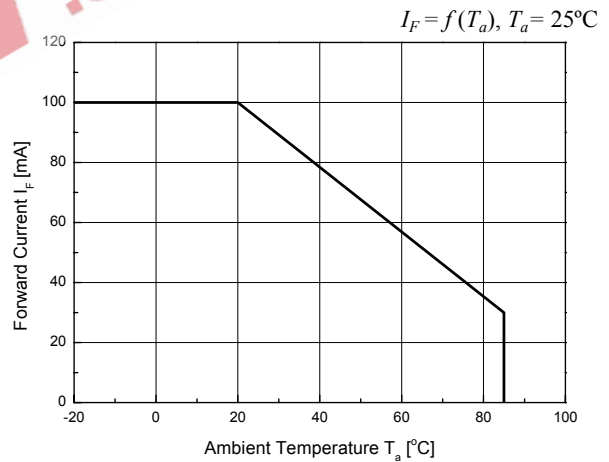

Ambient Temperature vs. Forward Current



7. Bin Code Description

**

BIN CODE		
Radiant Intensity	Peak Wavelength	Forward Voltage

Radiant Intensity (I_e) @ $I_F = 100\text{mA}$		
BIN CODE	Min.	Max.
A	30	55
B	55	65
C	65	70
D	70	130

Dominant Wavelength (nm) @ $I_F = 100\text{mA}$	
1	940

Forward Voltage (V) @ $I_F = 100\text{mA}$		
BIN CODE	Min.	Max.
1	1.2	1.55

** Note : Binning range can be changed by customer's requirement.



8. PACKING

1) Bulk Packing

(1) Antistatic poly vinyl bag apply

Poly bag:

5φ Lamp Series : 500pcs

3φ Lamp Series : 500pcs

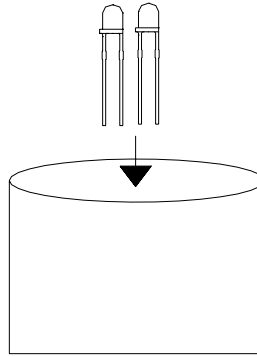

(2) Inner box structure

Box : 2 poly bags

		P/O No.
Lot No.		
SEOUL SEMICONDUCTOR CO.,LTD TEL : (02) 3281-6269		

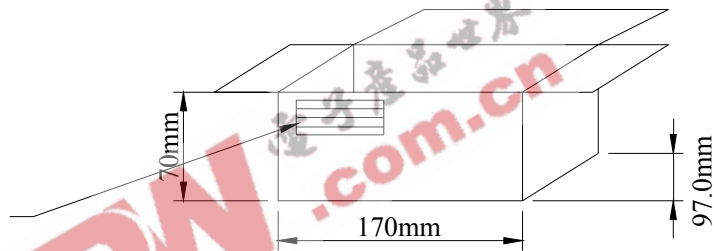

(3) Outer box structure

Box : 27 boxes

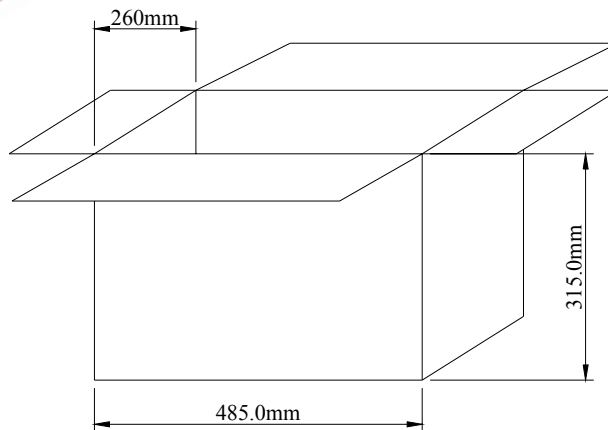

2) Tapping Outline Dimensions

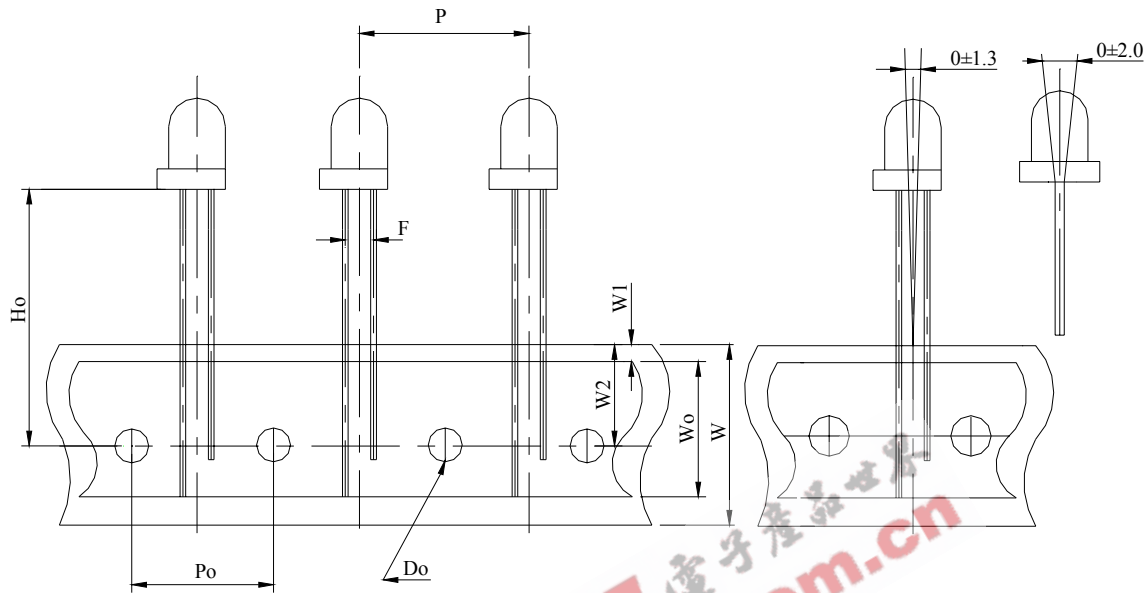

Package Dimensions (unit : mm)			
Ho*		P	12.7±0.5
W	18.0 ^{+1.0} _{-0.5}	Po	12.7±0.3
W0	13.0±0.3	F	2.54±0.5
W1	1.0±0.5	Do	φ4.0±0.5
W2	9.0±0.5		

* Remark : Ho - users define.

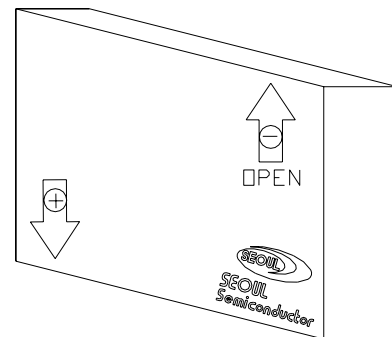

1 Box contain quantity.

* 3φ Lamp Series : 3000pcs

* 5φ Lamp Series : 2000pcs



3) Forming Outline Dimensions

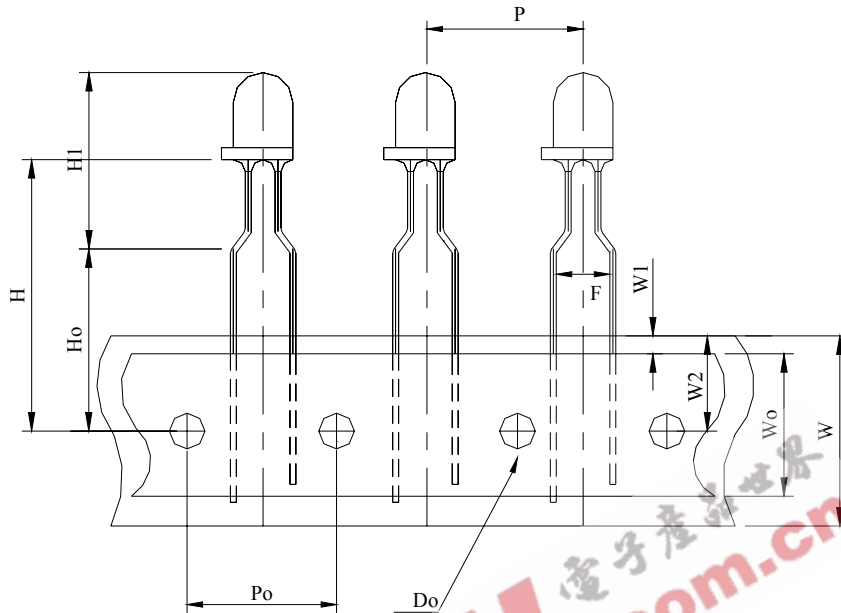

Package Dimensions (unit : mm)			
H *		W2	9.0±0.5
Ho *		P	12.7±0.5
H1 *		Po	12.7±0.3
W	18.0 ^{+1.0} _{-0.5}	F	5.0±0.5
Wo	13.0±0.3	Do	φ4.0±0.5
W1	1.0±0.5		

* Remark : H / Ho / H1- users define.

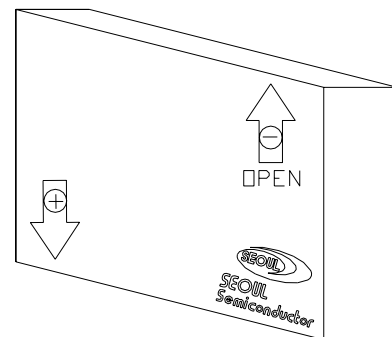

1 Box contain quantity.

* 3φ Lamp Series : 2000pcs

* 5φ Lamp Series : 1500pcs



9. SOLDERING PROFILE

1) Wave Soldering Conditions / Profile

- Preliminary heating to be at 85°C(120 °C max) for 20 seconds(60 seconds max).
- Soldering heat to be at 235 °C (260°C max) for 5 seconds (10 seconds max.)
- Soak time above 200 °C is 5 seconds

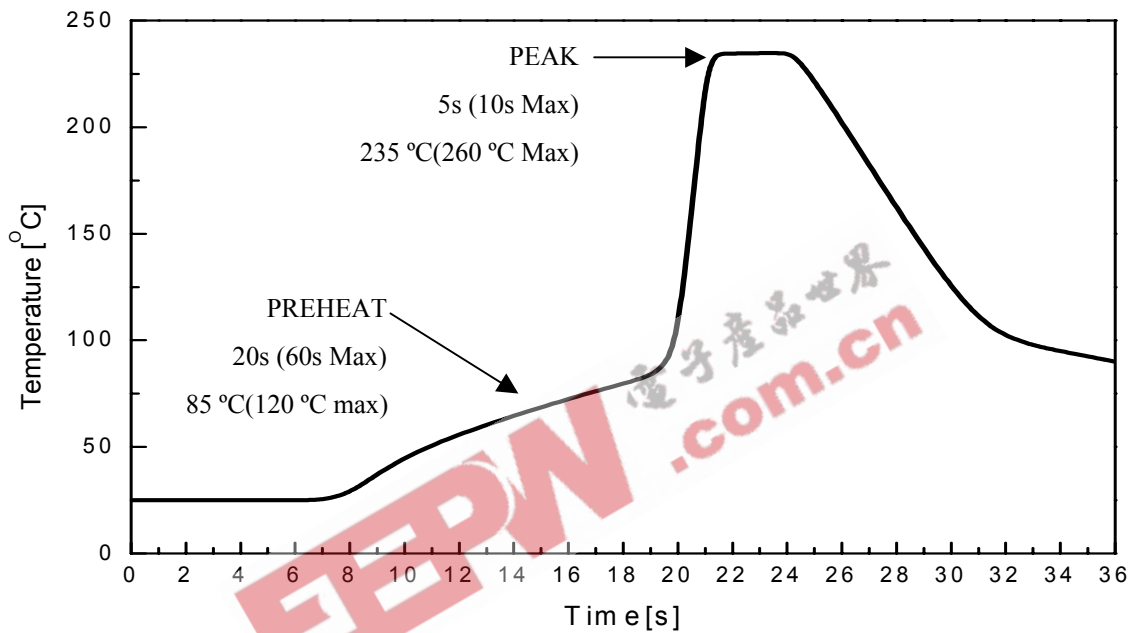

2) Hand Soldering conditions

- Not more than 5 seconds at max. 300°C, under Soldering iron.

Note : In case the soldered products are reused in soldering process, we don't guarantee the products.



10. PART NUMBERING SYSTEM

1	2	3	4	5	6	7	8		A	B	C
L	*	*	*	*	*	*	*	-	*	*	*

1) Lamp LED initial

2) Color

U: Ultra Violet, B : Blue (460~490), C : Cyan (490~510),
 T : True Green (510~540), G : Yellow-Green (540~580)
 Y : Yellow (580~600) O : Orange (600~620) R : Red (620~700)
 W : White M : Warm I : Infrared

3) If the products have 2 or 3chips

GR : Green + Red (according to wavelength), FL : Full color

4) Outline type

1 : 3x2(square), 2 : 5x2(square), 3 : Phi3, 5 : Phi 5 ,
 6 : 3Phi Oval, 7 : 5Phi Oval

5) Half angle

1: ~14°, 2: 15~24°, 3: 25~34°, 4: 35~44°, 5 : 45~54°... 0 : more than 100°

6) 1st Development according to a chip

7) 2nd Development (other material)

D : diffused C : colored Z : zener chip attached

8) Stand off type

A, B, C : Bin cord description A: IV, B: WD C: VF



11. PRECAUTION FOR USE

- 1) In order to avoid the absorption of moisture, it is recommended to store in the dry box (or desiccators) with a desiccant .
- 2) In case of more than 1 week passed after opening or change color of indicator on desiccant components shall be dried 10-12Hr, at $60\pm 5^{\circ}\text{C}$.
- 3) In case of supposed the components is humid, shall be dried dip-solder just before, 12Hr at $80\pm 5^{\circ}\text{C}$ or 10Hr at $100\pm 5^{\circ}\text{C}$.
- 4) Any mechanical force or any excess vibration shall not be accepted to apply during cooling process to normal temp. after soldering.
- 5) Quick cooling shall not be avoid.
- 6) Components shall not be mounted on warped direction of PCB.
- 7) Anti radioactive ray design is not considered for the products listed here in.
- 8) This device should not be used in any type of fluid such as water, oil, organic solvent and etc. When washing is required, IPA should be used.
- 9) When the LEDs are illuminating, operating current should be decided after considering the ambient maximum temperature.
- 10) LEDs must be stored to maintain a clean atmosphere. If the LEDs are stored for 3 months or more after being shipped from SSC, a sealed container with a nitrogen atmosphere should be used for storage.
- 11) The LEDs must be soldered within seven days after opening the moisture-proof packing.
- 12) Repack unused products with anti-moisture packing, fold to close any opening and then store in a dry place.
- 13) The appearance and specifications of the product may be modified for improvement without notice.

