

# **SPECIFICATIONS**

<b>MODEL</b>	<b>Infrared LAMP LED</b>
<b>PART NO.</b>	<b>LI520C</b>

## [Contents]

1.	Devices -----	1
2.	Outline Dimensions -----	1
3.	Absolute Maximum Ratings -----	2
4.	Electro-Optical Characteristics -----	3
5.	Reliability Tests -----	4
6.	Characteristic Diagrams -----	5
7.	Bin Code Description -----	6
8.	Packing -----	7
9.	Soldering Profile -----	10
10.	Reference -----	11
11.	Precaution For Use -----	12

## 1. Devices

Part Number	Lens		Source	
	Color	Diffusion	Dice Source	Color
LI520C	Blue -Risen	Non-Diffused	GaAlAs/GaAs	Infrared

## 2. Outline Dimensions

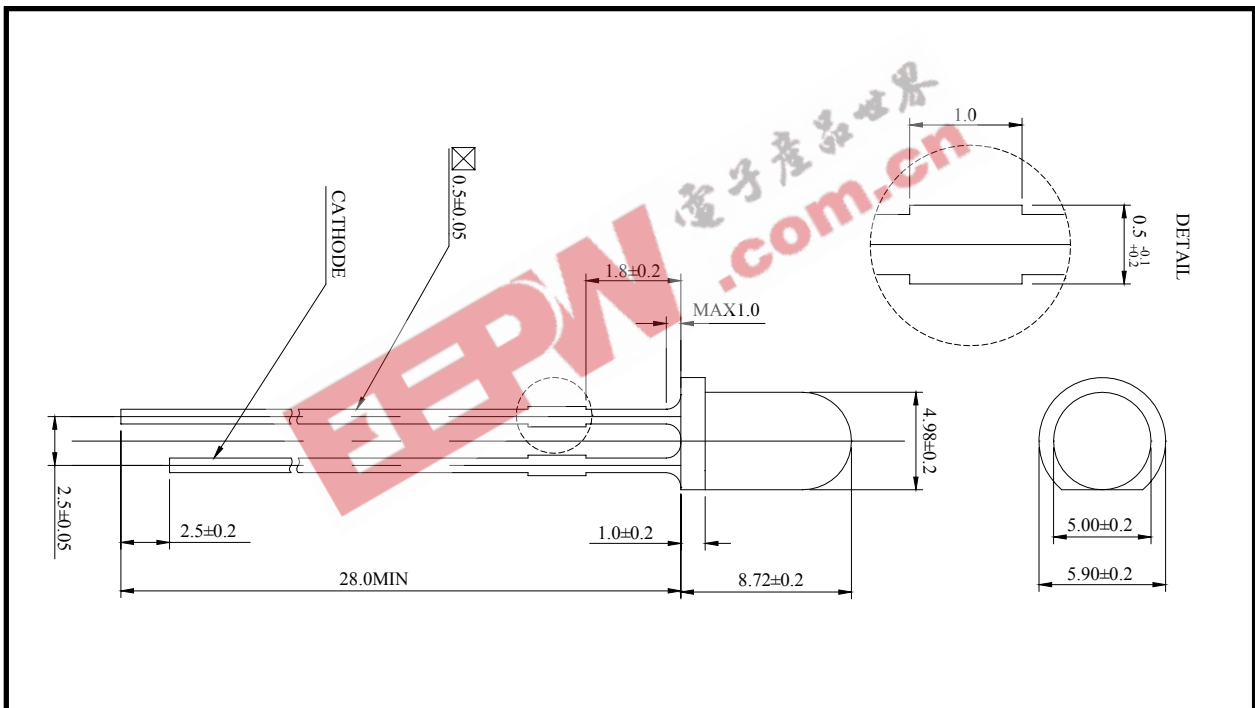

- Notes : 1. All dimensions are in millimeters.  
2. Protruded epoxy is 1.0mm maximum.



### 3. Absolute Maximum Ratings (at $T_a = 25^\circ\text{C}$ )

Item	Symbol	Value	Unit
DC Forward Current	$I_F$	100	mA
Forward Peak Pulse Current	$I_{FM}^{*1}$	1000	mA
Reverse Voltage	$V_R$	5	V
Power Dissipation	$P_D$	150	mW
Operating Temperature	$T_{opr}$	-20 ~ +80	$^\circ\text{C}$
Storage Temperature	$T_{stg}$	-30 ~ +100	$^\circ\text{C}$
Solder Temperature	$T_S$	260 $^\circ\text{C}$ for 5 second <sup>*2</sup>	$^\circ\text{C}$

Notes : \*1.  $t \leq 0.01\text{ms}$ ,  $D = 1/100$

\*2. 3mm bellow seating plane



#### 4. Electro-Optical Characteristics (at $I_F = 100\text{mA}$ , $T_a = 25^\circ\text{C}$ )

Item	Symbol	Value			Unit
		Min.	Typ.	Max.	
Radiant Intensity	$I_e$	30	65	130	mW/sr
Peak Wavelength	$\lambda_p$	-	940	-	nm
Spectrum Radiation Bandwidth	$\Delta\lambda$	-	50	-	nm
Forward Voltage	$V_F$	-	1.2	1.55	V
View Angle	$2\theta_{1/2}$	24			deg.
Reverse Current (at $V_R = 5\text{V}$ )	$I_R$	10			$\mu\text{A}$

Note : 1. Radiant Intensity Tolerance  $\pm 10\%$



## 5. RELIABILITY TESTS

Item	Condition	Note	Failures
Life Test	$T_a = RT, I_F = 100mA$	1000 hrs	0/22
High Temperature Operating	$T_a = 85^{\circ}C, I_F = 25mA$	1000 hrs	0/22
Low Temperature Operating	$T_a = -40^{\circ}C, I_F = 100mA$	1000 hrs	0/22
Thermal Shock	$T_a = -30^{\circ}C \sim +100^{\circ}$ (Transfer time : 5sec , 1 Cycle =1hr)	100 cycles	0/22
Temperature Cycle	$T_a = -20^{\circ}C \sim +80^{\circ}C$ (Transfer time : 5min , 1 Cycle =1hr)	100 cycles	0/22
Resistance to soldering Heat	$T_s = 260 \pm 5^{\circ}C, t = 10 \pm 1 \text{ sec}$	1 time	0/22
ESD (Human Body Model)	1 kV, 1.5 k $\Omega$ ; 100 pF	1 time	0/22
High Temperature Storage	$T_a = 100^{\circ}C$	1000 hrs	0/22
Low Temperature Storage	$T_a = -30^{\circ}C$	1000 hrs	0/22
Temperature Humidity Storage	$T_a = +85^{\circ}C, RH=85\%$	1000hrs	0/22
Temperature Humidity Operating	$T_a = +85^{\circ}C, RH=85\%$ $I_F = 25mA$	100hrs	0/22

### < Judging Criteria For Reliability Tests >

V <sub>F</sub>	USL <sup>1</sup> X 1.2
I <sub>R</sub>	USL X 2.0
I <sub>V</sub>	LSL <sup>2</sup> X 0.5

Notes : 1.USL : Upper Standard Level      2.LSL : Lower Standard Level.



## 6. Characteristic Diagrams

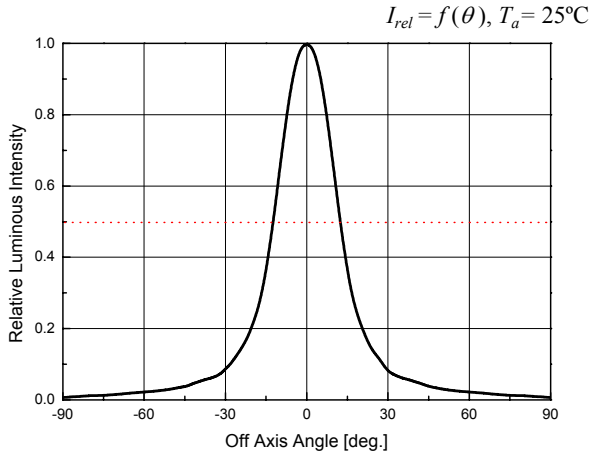

Off Axis Angle vs. Relative Radiant Intensity

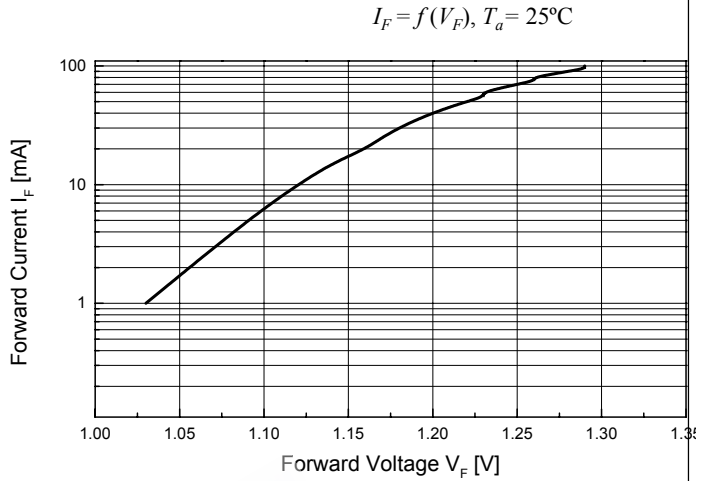

Forward Voltage vs. Forward Current

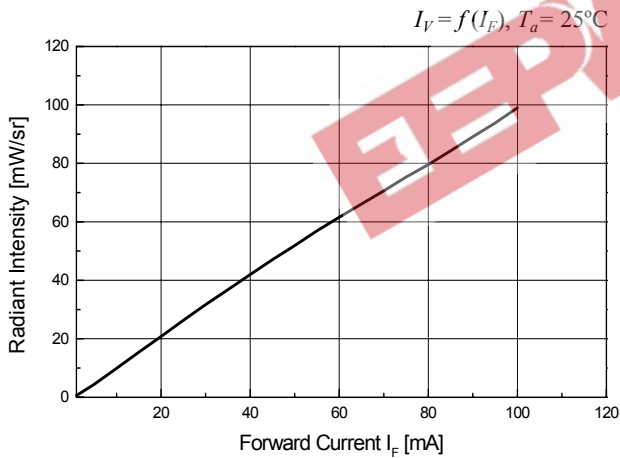

Forward Current vs. Radiant Intensity

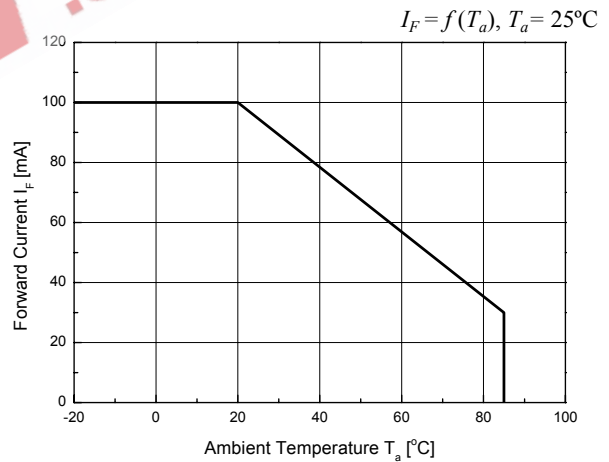

Ambient Temperature vs. Forward Current



## 7. Bin Code Description

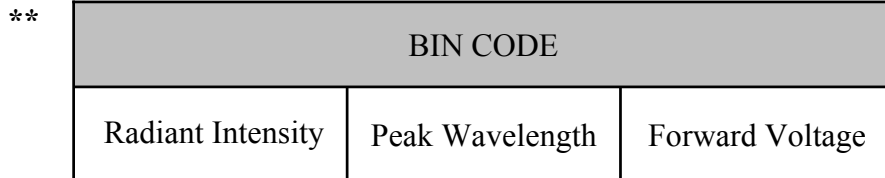

Radiant Intensity ( $I_e$ ) @ $I_F = 100\text{mA}$		
BIN CODE	Min.	Max.
A	30	55
B	55	65
C	65	70
D	70	130

Dominant Wavelength (nm) @ $I_F = 100\text{mA}$	
1	940

Forward Voltage (V) @ $I_F = 100\text{mA}$		
BIN CODE	Min.	Max.
1	1.2	1.55

\*\* Note : Binning range can be changed by customer's requirement.



## 8. PACKING

### 1) Bulk Packing

#### (1) Antistatic poly vinyl bag apply

Poly bag:

5φ Lamp Series : 500pcs

3φ Lamp Series : 500pcs

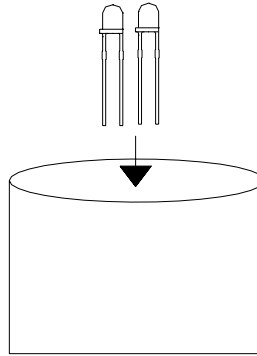

#### (2) Inner box structure

Box : 2 poly bags

		P/O No.
Lot No.		
SEOUL SEMICONDUCTOR CO.,LTD TEL : (02) 3281-6269		

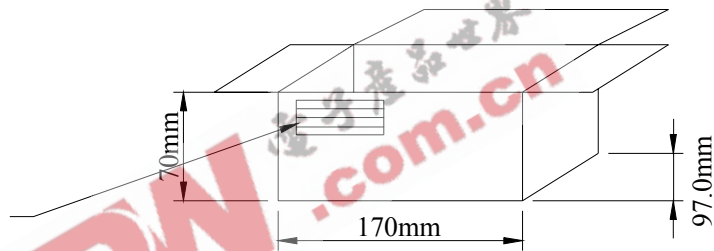

#### (3) Outer box structure

Box : 27 boxes

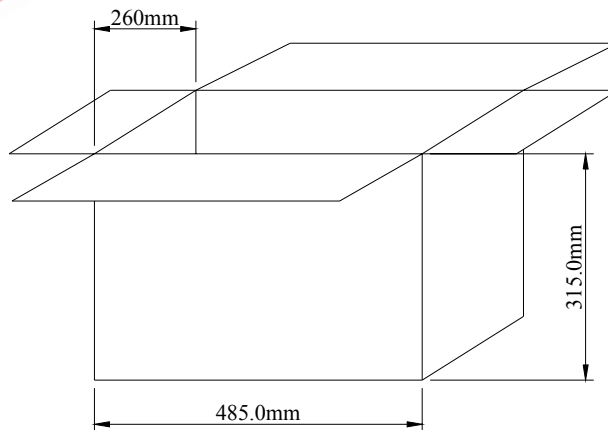



## 2) Tapping Outline Dimensions

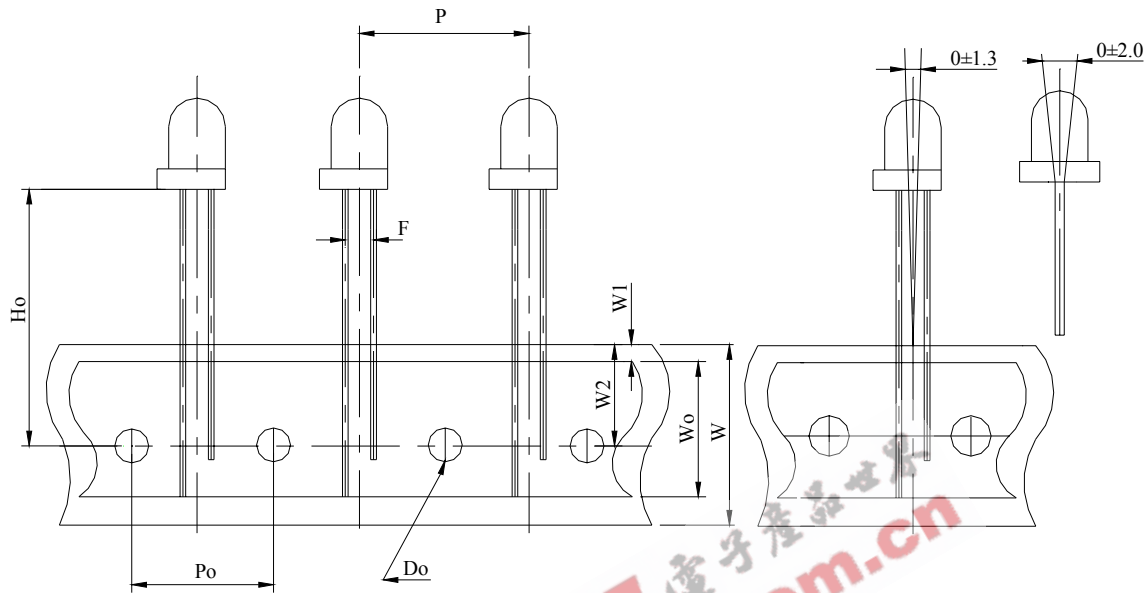

Package Dimensions (unit : mm)			
Ho*		P	12.7±0.5
W	18.0 <sup>+1.0</sup> <sub>-0.5</sub>	Po	12.7±0.3
W0	13.0±0.3	F	2.54±0.5
W1	1.0±0.5	Do	φ4.0±0.5
W2	9.0±0.5		

\* Remark : Ho - users define.

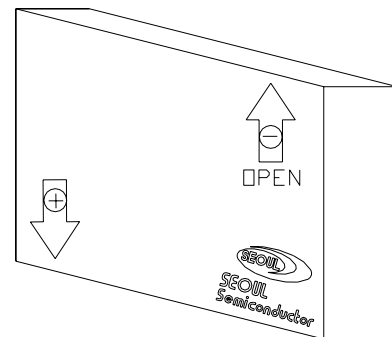

1 Box contain quantity.

\* 3φ Lamp Series : 3000pcs

\* 5φ Lamp Series : 2000pcs



### 3) Forming Outline Dimensions

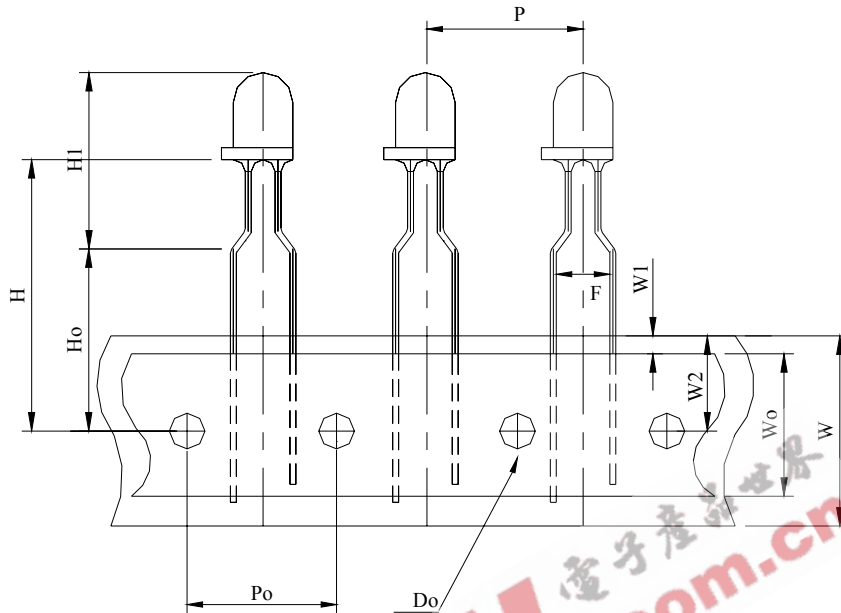

Package Dimensions (unit : mm)			
H *		W2	9.0±0.5
Ho *		P	12.7±0.5
H1 *		Po	12.7±0.3
W	18.0 <sup>+1.0</sup> <sub>-0.5</sub>	F	5.0±0.5
Wo	13.0±0.3	Do	φ4.0±0.5
W1	1.0±0.5		

\* Remark : H / Ho / H1- users define.

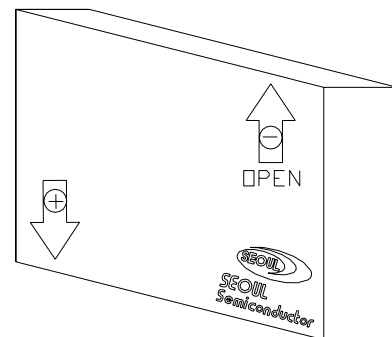

1 Box contain quantity.

\* 3φ Lamp Series : 2000pcs

\* 5φ Lamp Series : 1500pcs



## 9. SOLDERING PROFILE

### 1) Wave Soldering Conditions / Profile

- Preliminary heating to be at 85°C(120 °C max) for 20 seconds(60 seconds max).
- Soldering heat to be at 235 °C (260°C max) for 5 seconds (10 seconds max.)
- Soak time above 200 °C is 5 seconds

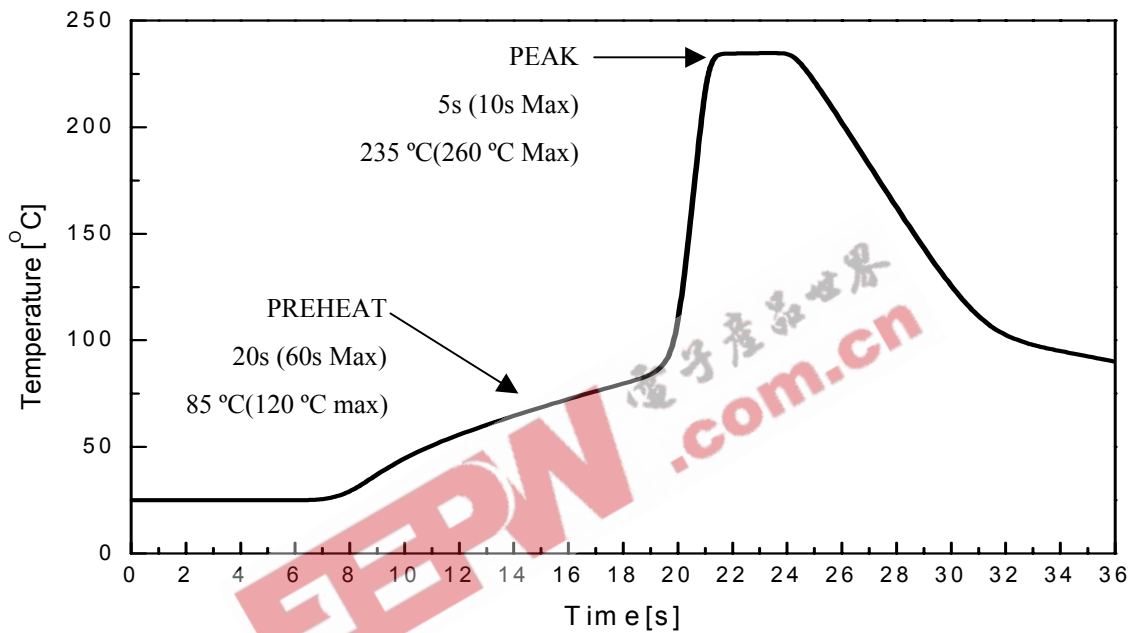

### 2) Hand Soldering conditions

- Not more than 5 seconds at max. 300°C, under Soldering iron.

Note : In case the soldered products are reused in soldering process, we don't guarantee the products.



## 10. PART NUMBERING SYSTEM

1	2	3	4	5	6	7	8		A	B	C
L	*	*	*	*	*	*	*	-	*	*	*

1) Lamp LED initial

2) Color

U: Ultra Violet,                      B : Blue (460~490),                      C : Cyan (490~510),  
 T : True Green (510~540), G : Yellow-Green (540~580)  
 Y : Yellow (580~600)                      O : Orange (600~620)                      R : Red (620~700)  
 W : White                                      M : Warm                                      I : Infrared

3) If the products have 2 or 3chips

GR : Green + Red ( according to wavelength), FL : Full color

4) Outline type

1 : 3x2(square),                      2 : 5x2(square),                      3 : Phi3,                      5 : Phi 5 ,  
 6 : 3Phi Oval,                      7 : 5Phi Oval

5) Half angle

1: ~14°, 2: 15~24°, 3: 25~34°, 4: 35~44°, 5 : 45~54°... 0 : more than 100°

6) 1<sup>st</sup> Development according to a chip

7) 2<sup>nd</sup> Development (other material)

D : diffused C : colored Z : zener chip attached

8) Stand off type

A, B, C : Bin cord description A: IV, B: WD C: VF



## 11. PRECAUTION FOR USE

- 1) In order to avoid the absorption of moisture, it is recommended to store in the dry box (or desiccators) with a desiccant .
- 2) In case of more than 1 week passed after opening or change color of indicator on desiccant components shall be dried 10-12Hr, at  $60\pm 5^{\circ}\text{C}$ .
- 3) In case of supposed the components is humid, shall be dried dip-solder just before, 12Hr at  $80\pm 5^{\circ}\text{C}$  or 10Hr at  $100\pm 5^{\circ}\text{C}$ .
- 4) Any mechanical force or any excess vibration shall not be accepted to apply during cooling process to normal temp. after soldering.
- 5) Quick cooling shall not be avoid.
- 6) Components shall not be mounted on warped direction of PCB.
- 7) Anti radioactive ray design is not considered for the products listed here in.
- 8) This device should not be used in any type of fluid such as water, oil, organic solvent and etc. When washing is required, IPA should be used.
- 9) When the LEDs are illuminating, operating current should be decided after considering the ambient maximum temperature.
- 10) LEDs must be stored to maintain a clean atmosphere. If the LEDs are stored for 3 months or more after being shipped from SSC, a sealed container with a nitrogen atmosphere should be used for storage.
- 11) The LEDs must be soldered within seven days after opening the moisture-proof packing.
- 12) Repack unused products with anti-moisture packing, fold to close any opening and then store in a dry place.
- 13) The appearance and specifications of the product may be modified for improvement without notice.

