

# LM317M

## 500 mA Adjustable Output, Positive Voltage Regulator

The LM317M is an adjustable three-terminal positive voltage regulator capable of supplying in excess of 500 mA over an output voltage range of 1.2 V to 37 V. This voltage regulator is exceptionally easy to use and requires only two external resistors to set the output voltage. Further, it employs internal current limiting, thermal shutdown and safe area compensation, making it essentially blow-out proof.

The LM317M serves a wide variety of applications including local, on-card regulation. This device also makes an especially simple adjustable switching regulator, a programmable output regulator, or by connecting a fixed resistor between the adjustment and output, the LM317M can be used as a precision current regulator.

### Features

- Output Current in Excess of 500 mA
- Output Adjustable between 1.2 V and 37 V
- Internal Thermal Overload Protection
- Internal Short Circuit Current Limiting
- Output Transistor Safe-Area Compensation
- Floating Operation for High Voltage Applications
- Eliminates Stocking Many Fixed Voltages
- Pb-Free Packages are Available

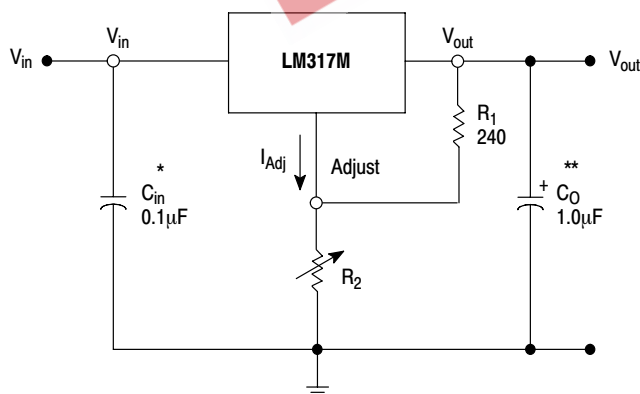

\* =  $C_{in}$  is required if regulator is located an appreciable distance from power supply filter.

\*\* =  $C_O$  is not needed for stability, however, it does improve transient response.

$$V_{out} = 1.25 V \left( 1 + \frac{R_2}{R_1} \right) + I_{Adj} R_2$$

Since  $I_{Adj}$  is controlled to less than 100  $\mu A$ , the error associated with this term is negligible in most applications.

Figure 1. Simplified Application



ON Semiconductor®

<http://onsemi.com>

Heatsink surface  
connected to Pin 2

TO-220AB  
T SUFFIX  
CASE 221AB

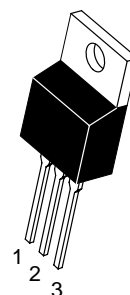

SOT-223  
ST SUFFIX  
CASE 318E



DPAK  
DT SUFFIX  
CASE 369C

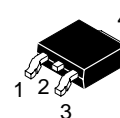

Heatsink Surface (shown as terminal 4 in  
case outline drawing) is connected to Pin 2.

### PIN ASSIGNMENT

1	Adjust
2	$V_{out}$
3	$V_{in}$

### ORDERING INFORMATION

See detailed ordering and shipping information in the package dimensions section on page 10 of this data sheet.

### DEVICE MARKING INFORMATION

See general marking information in the device marking section on page 11 of this data sheet.

# LM317M

## MAXIMUM RATINGS (T<sub>A</sub> = 25°C, unless otherwise noted.)

Rating	Symbol	Value	Unit
Input–Output Voltage Differential	V <sub>I</sub> –V <sub>O</sub>	40	Vdc
Power Dissipation (Package Limitation) (Note 1) Plastic Package, T Suffix, Case 221A T <sub>A</sub> = 25°C Thermal Resistance, Junction–to–Air Thermal Resistance, Junction–to–Case	P <sub>D</sub> θ <sub>JA</sub> θ <sub>JC</sub>	Internally Limited 70 5.0	°C/W °C/W
Plastic Package, DT Suffix, Case 369C T <sub>A</sub> = 25°C Thermal Resistance, Junction–to–Air Thermal Resistance, Junction–to–Case	P <sub>D</sub> θ <sub>JA</sub> θ <sub>JC</sub>	Internally Limited 92 5.0	°C/W °C/W
Plastic Package, ST Suffix, Case 318E T <sub>A</sub> = 25°C Thermal Resistance, Junction–to–Air Thermal Resistance, Junction–to–Case	P <sub>D</sub> θ <sub>JA</sub> θ <sub>JC</sub>	Internally Limited 245 15	°C/W °C/W
Operating Junction Temperature Range	T <sub>J</sub>	–40 to +125	°C
Storage Temperature Range	T <sub>stg</sub>	–65 to +150	°C

Stresses exceeding Maximum Ratings may damage the device. Maximum Ratings are stress ratings only. Functional operation above the Recommended Operating Conditions is not implied. Extended exposure to stresses above the Recommended Operating Conditions may affect device reliability.

1. Figure 25 provides thermal resistance versus PC board pad size.

## ELECTRICAL CHARACTERISTICS (V<sub>I</sub> – V<sub>O</sub> = 5.0 V; I<sub>O</sub> = 0.1 A, T<sub>J</sub> = T<sub>low</sub> to T<sub>high</sub> (Note 2), unless otherwise noted.)

Characteristics	Figure	Symbol	LM317M / LM317MB			Unit
			Min	Typ	Max	
Line Regulation (Note 3) (T <sub>A</sub> = 25°C, 3.0 V ≤ V <sub>I</sub> – V <sub>O</sub> ≤ 40 V)	3	Reg <sub>line</sub>	–	0.01	0.04	%/V
Load Regulation (Note 3) T <sub>A</sub> = 25°C, 10 mA ≤ I <sub>O</sub> ≤ 0.5 A V <sub>O</sub> ≤ 5.0 V V <sub>O</sub> ≥ 5.0 V	4	Reg <sub>load</sub>	– –	5.0 0.1	25 0.5	mV % V <sub>O</sub>
Adjustment Pin Current	5	I <sub>Adj</sub>	–	50	100	μA
Adjustment Pin Current Change 2.5 V ≤ V <sub>I</sub> – V <sub>O</sub> ≤ 40 V, 10 mA ≤ I <sub>L</sub> ≤ 0.5 A, P <sub>D</sub> ≤ P <sub>max</sub>	3, 4	ΔI <sub>Adj</sub>	–	0.2	5.0	μA
Reference Voltage 3.0 V ≤ V <sub>I</sub> – V <sub>O</sub> ≤ 40 V, 10 mA ≤ I <sub>L</sub> ≤ 0.5 A, P <sub>D</sub> ≤ P <sub>max</sub>	5	V <sub>ref</sub>	1.200	1.250	1.300	V
Line Regulation (Note 3) 3.0 V ≤ V <sub>I</sub> –V <sub>O</sub> ≤ 40 V	3	Reg <sub>line</sub>	–	0.02	0.07	%/V
Load Regulation (Note 3) 10 mA ≤ I <sub>O</sub> ≤ 0.5 A V <sub>O</sub> ≤ 5.0 V V <sub>O</sub> ≥ 5.0 V	4	Reg <sub>load</sub>	– –	20 0.3	70 1.5	mV % V <sub>O</sub>
Temperature Stability (T <sub>low</sub> ≤ T <sub>J</sub> ≤ T <sub>high</sub> )	5	T <sub>S</sub>	–	0.7	–	% V <sub>O</sub>
Minimum Load Current to Maintain Regulation (V <sub>I</sub> – V <sub>O</sub> = 40 V)	5	I <sub>Lmin</sub>	–	3.5	10	mA
Maximum Output Current V <sub>I</sub> – V <sub>O</sub> ≤ 15 V, P <sub>D</sub> ≤ P <sub>max</sub> V <sub>I</sub> – V <sub>O</sub> = 40 V, P <sub>D</sub> ≤ P <sub>max</sub> , T <sub>A</sub> = 25°C	5	I <sub>max</sub>	0.5 0.15	0.9 0.25	– –	A
RMS Noise, % of V <sub>O</sub> (T <sub>A</sub> = 25°C, 10 Hz ≤ f ≤ 10 kHz)	–	N	–	0.003	–	% V <sub>O</sub>
Ripple Rejection, V <sub>O</sub> = 10 V, f = 120 Hz (Note 4) Without C <sub>Adj</sub> C <sub>Adj</sub> = 10 μF	6	RR	– 66	65 80	– –	dB
Long–Term Stability, T <sub>J</sub> = T <sub>high</sub> (Note 5) T <sub>A</sub> = 25°C for End–point Measurements	5	S	–	0.3	1.0	%/1.0 kHrs.

2. T<sub>low</sub> to T<sub>high</sub> = 0° to +125°C for LM317M T<sub>low</sub> to T<sub>high</sub> = –40° to +125°C for LM317MB.

3. Load and line regulation are specified at constant junction temperature. Changes in V<sub>O</sub> due to heating effects must be taken into account separately. Pulse testing with low duty cycle is used.

4. C<sub>Adj</sub>, when used, is connected between the adjustment pin and ground.

5. Since Long–Term Stability cannot be measured on each device before shipment, this specification is an engineering estimate of average stability from lot–to–lot.

## LM317M

### ELECTRICAL CHARACTERISTICS ( $V_I - V_O = 5.0\text{ V}$ ; $I_O = 0.1\text{ A}$ , $T_J = T_{\text{low}}$ to $T_{\text{high}}$ (Note 6), unless otherwise noted.)

Characteristics	Figure	Symbol	LM317MA / LM317MAB			Unit
			Min	Typ	Max	
Line Regulation (Note 7) ( $T_A = 25^\circ\text{C}$ , $3.0\text{ V} \leq V_I - V_O \leq 40\text{ V}$ )	3	$\text{Reg}_{\text{line}}$	–	0.01	0.04	%/V
Load Regulation (Note 7) $T_A = 25^\circ\text{C}$ , $10\text{ mA} \leq I_O \leq 0.5\text{ A}$ $V_O \leq 5.0\text{ V}$ $V_O \geq 5.0\text{ V}$	4	$\text{Reg}_{\text{load}}$	– –	5.0 0.1	25 0.5	mV % $V_O$
Adjustment Pin Current	5	$I_{\text{Adj}}$	–	50	100	$\mu\text{A}$
Adjustment Pin Current Change $2.5\text{ V} \leq V_I - V_O \leq 40\text{ V}$ , $10\text{ mA} \leq I_L \leq 0.5\text{ A}$ , $P_D \leq P_{\text{max}}$	3, 4	$\Delta I_{\text{Adj}}$	–	0.2	5.0	$\mu\text{A}$
Reference Voltage $3.0\text{ V} \leq V_I - V_O \leq 40\text{ V}$ , $10\text{ mA} \leq I_L \leq 0.5\text{ A}$ , $P_D \leq P_{\text{max}}$	5	$V_{\text{ref}}$	1.225	1.250	1.275	V
Line Regulation (Note 7) $3.0\text{ V} \leq V_I - V_O \leq 40\text{ V}$	3	$\text{Reg}_{\text{line}}$	–	0.02	0.07	%/V
Load Regulation (Note 7) $10\text{ mA} \leq I_O \leq 0.5\text{ A}$ $V_O \leq 5.0\text{ V}$ $V_O \geq 5.0\text{ V}$	4	$\text{Reg}_{\text{load}}$	– –	20 0.3	70 1.5	mV % $V_O$
Temperature Stability ( $T_{\text{low}} \leq T_J \leq T_{\text{high}}$ )	5	$T_S$	–	0.7	–	% $V_O$
Minimum Load Current to Maintain Regulation ( $V_I - V_O = 40\text{ V}$ )	5	$I_{\text{Lmin}}$	–	3.5	10	mA
Maximum Output Current $V_I - V_O \leq 15\text{ V}$ , $P_D \leq P_{\text{max}}$ $V_I - V_O = 40\text{ V}$ , $P_D \leq P_{\text{max}}$ , $T_A = 25^\circ\text{C}$	5	$I_{\text{max}}$	0.5 0.15	0.9 0.25	– –	A
RMS Noise, % of $V_O$ ( $T_A = 25^\circ\text{C}$ , $10\text{ Hz} \leq f \leq 10\text{ kHz}$ )	–	N	–	–	–	% $V_O$
Ripple Rejection, $V_O = 10\text{ V}$ , $f = 120\text{ Hz}$ (Note 8) Without $C_{\text{Adj}}$ $C_{\text{Adj}} = 10\text{ }\mu\text{F}$	6	RR	– 66	65 80	– –	dB
Long-Term Stability, $T_J = T_{\text{high}}$ (Note 9) $T_A = 25^\circ\text{C}$ for End-point Measurements	5	S	–	0.3	1.0	%/1.0 kHrs.

6.  $T_{\text{low}}$  to  $T_{\text{high}} = 0^\circ$  to  $+125^\circ\text{C}$  for LM317MA.  $T_{\text{low}}$  to  $T_{\text{high}} = -40^\circ$  to  $+125^\circ\text{C}$  for LM317MAB.

7. Load and line regulation are specified at constant junction temperature. Changes in  $V_O$  due to heating effects must be taken into account separately. Pulse testing with low duty cycle is used.

8.  $C_{\text{Adj}}$ , when used, is connected between the adjustment pin and ground.

9. Since Long-Term Stability cannot be measured on each device before shipment, this specification is an engineering estimate of average stability from lot-to-lot.

## LM317M

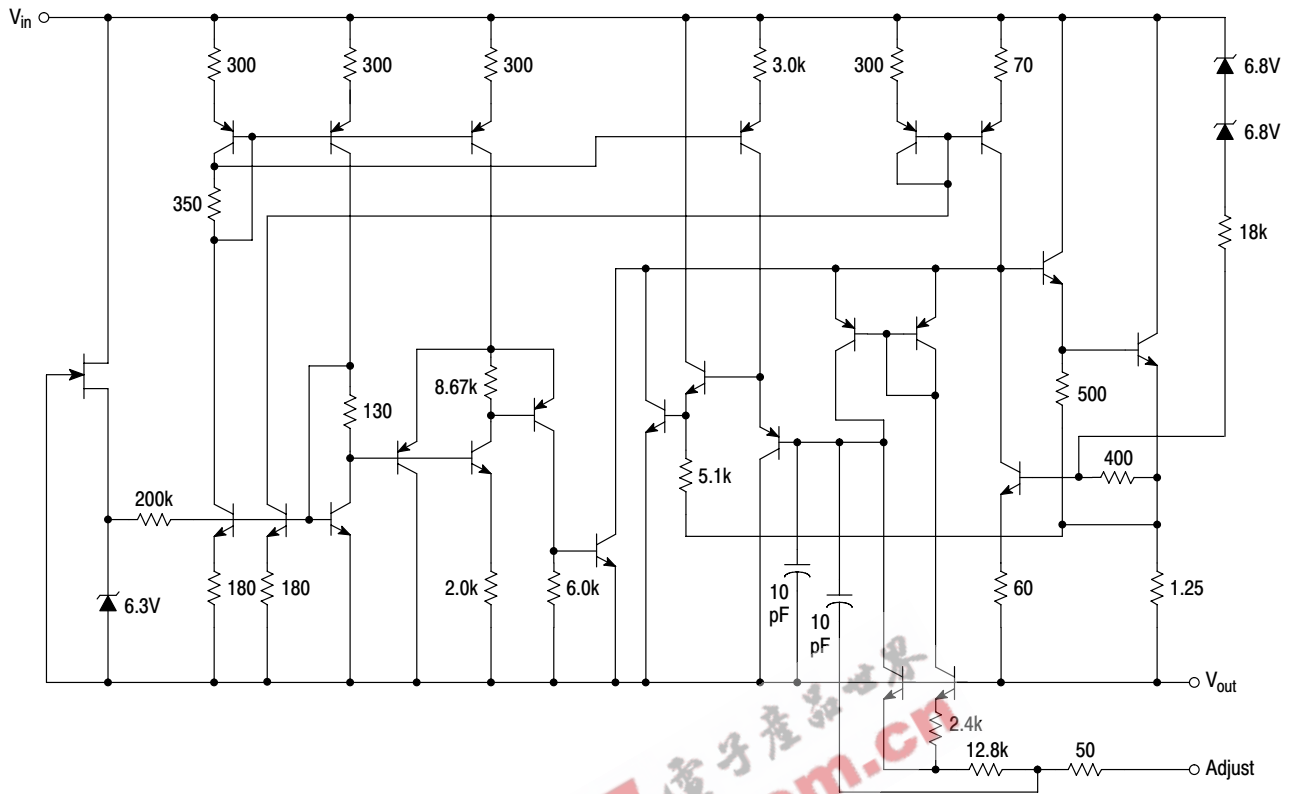

**Figure 2. Representative Schematic Diagram**

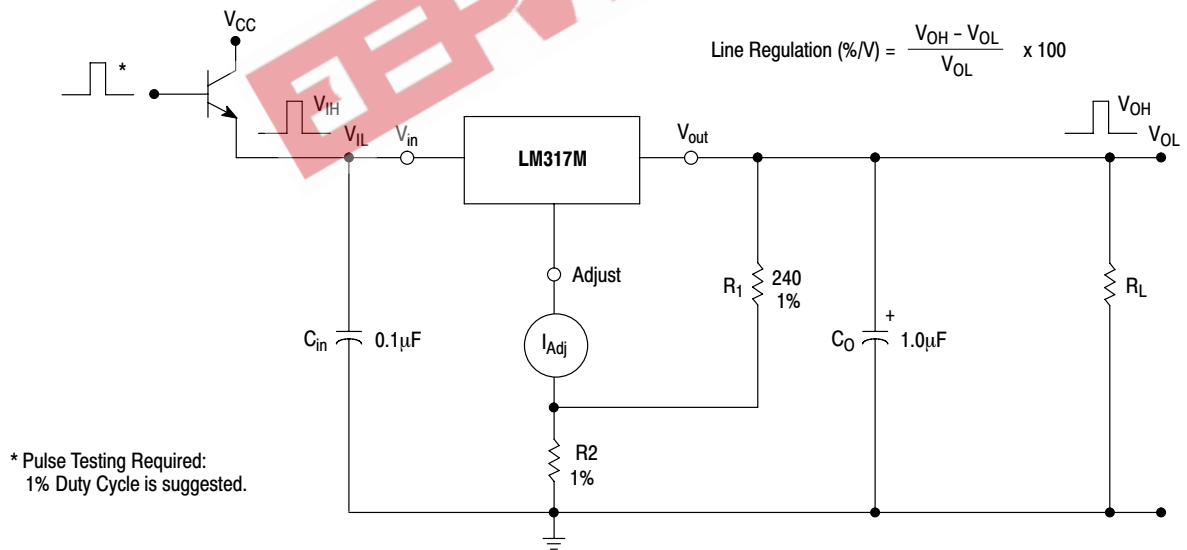
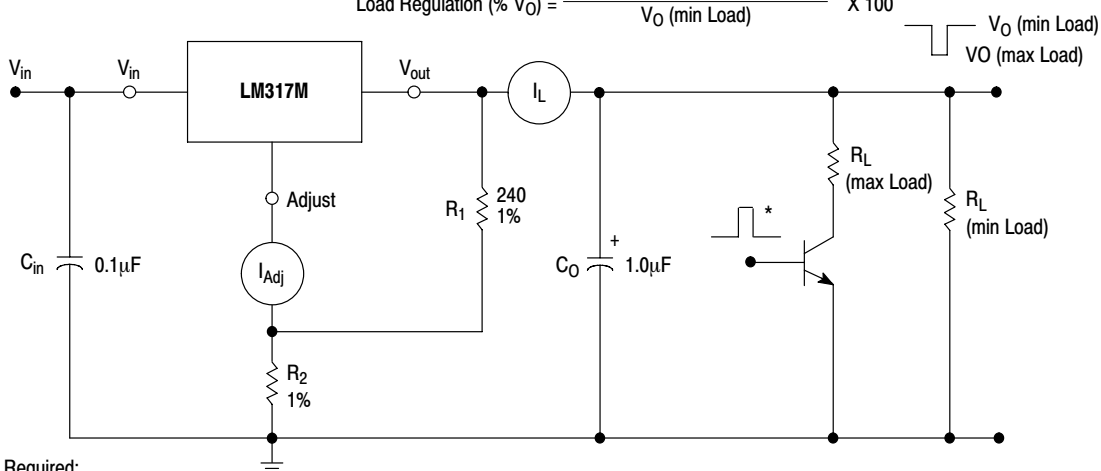

**Figure 3. Line Regulation and  $\Delta I_{Adj}$ /Line Test Circuit**

## LM317M

$$\text{Load Regulation (mV)} = V_O (\text{min Load}) - V_O (\text{max Load})$$

$$\text{Load Regulation (\% } V_O) = \frac{V_O (\text{min Load}) - V_O (\text{max Load})}{V_O (\text{min Load})} \times 100$$



\* Pulse Testing Required:  
1% Duty Cycle is suggested.

**Figure 4. Load Regulation and  $\Delta I_{Adj}$ /Load Test Circuit**

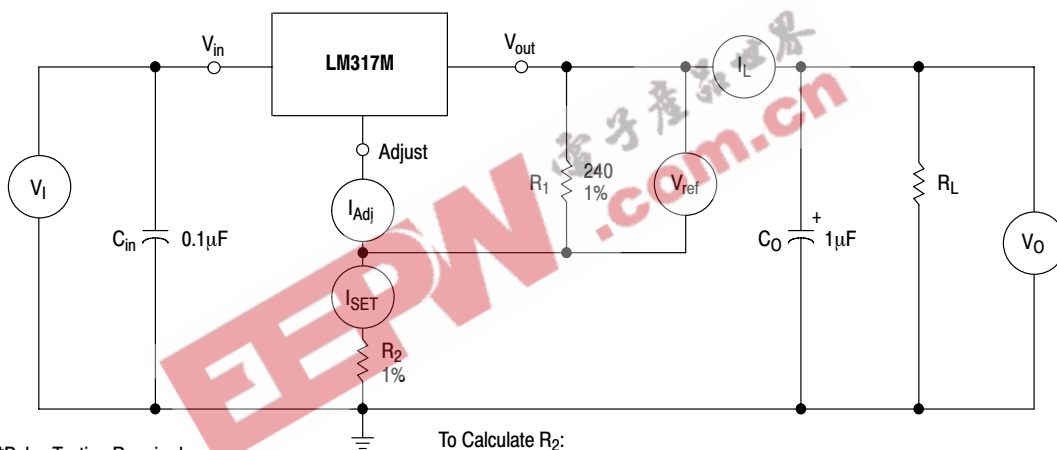

\*Pulse Testing Required:  
1% Duty Cycle is suggested.

To Calculate  $R_2$ :  
 $V_{out} = I_{SET} R_2 + 1.250 \text{ V}$   
Assume  $I_{SET} = 5.25 \text{ mA}$

**Figure 5. Standard Test Circuit**

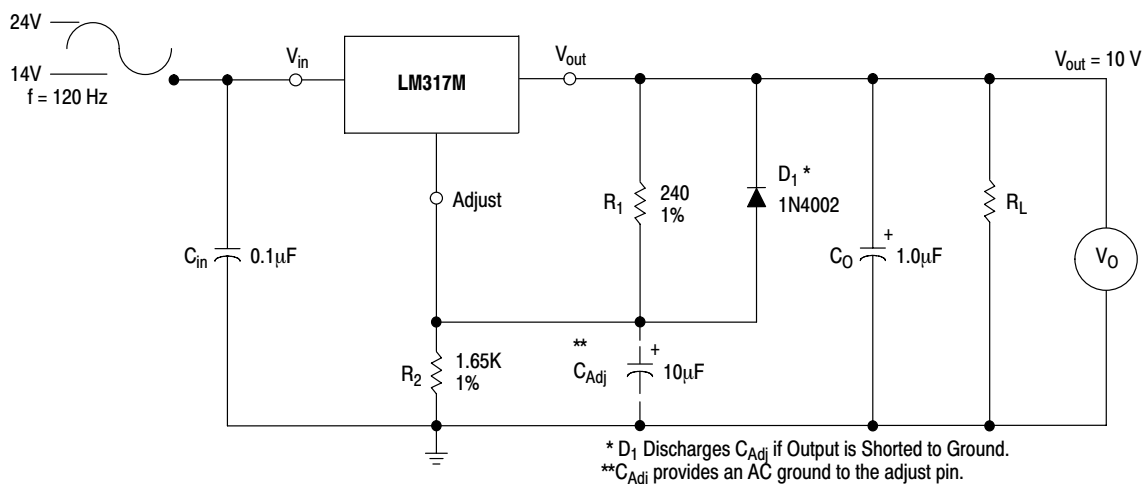

\*  $D_1$  Discharges  $C_{Adj}$  if Output is Shorted to Ground.  
\*\*  $C_{Adj}$  provides an AC ground to the adjust pin.

**Figure 6. Ripple Rejection Test Circuit**

# LM317M

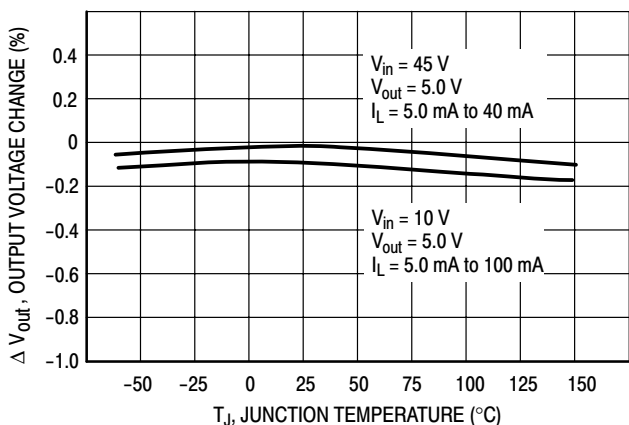

Figure 7. Load Regulation

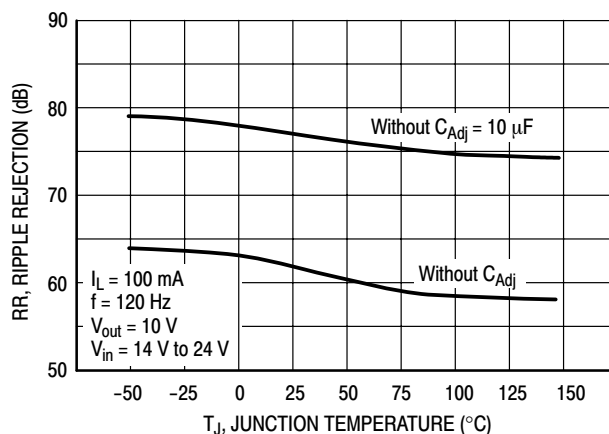

Figure 8. Ripple Rejection

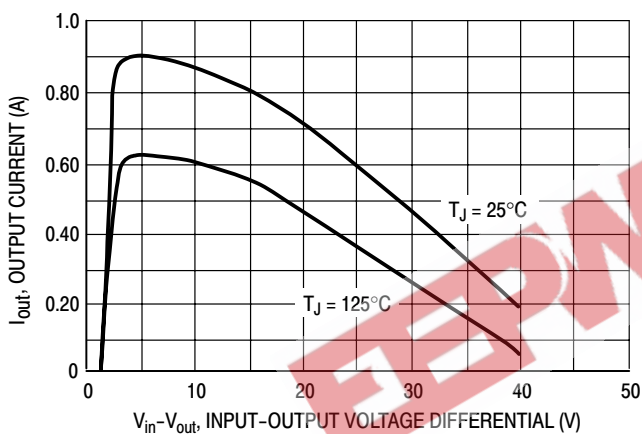

Figure 9. Current Limit

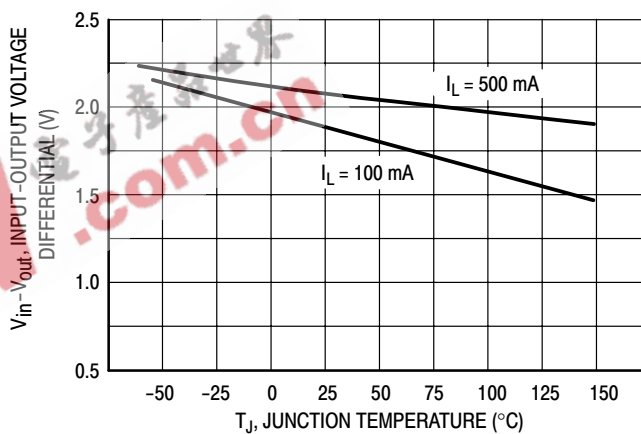

Figure 10. Dropout Voltage

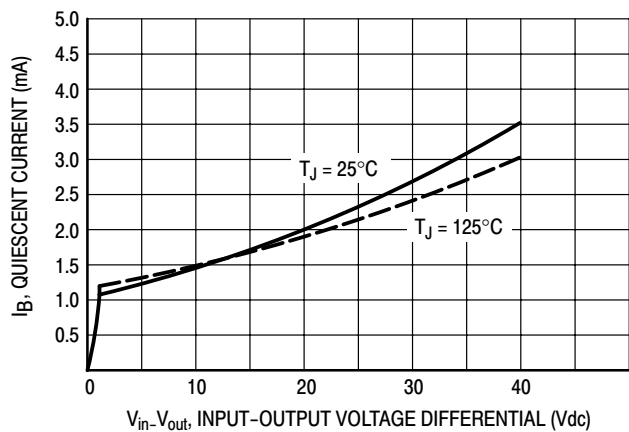

Figure 11. Minimum Operating Current

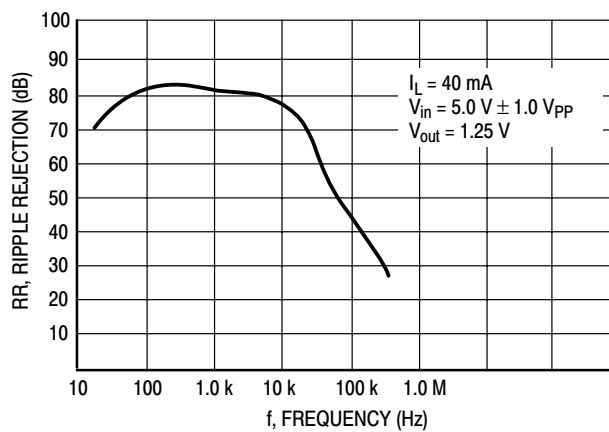

Figure 12. Ripple Rejection versus Frequency

# LM317M

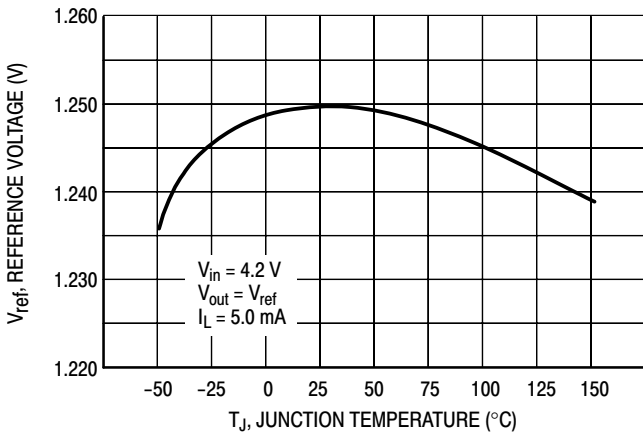

Figure 13. Temperature Stability

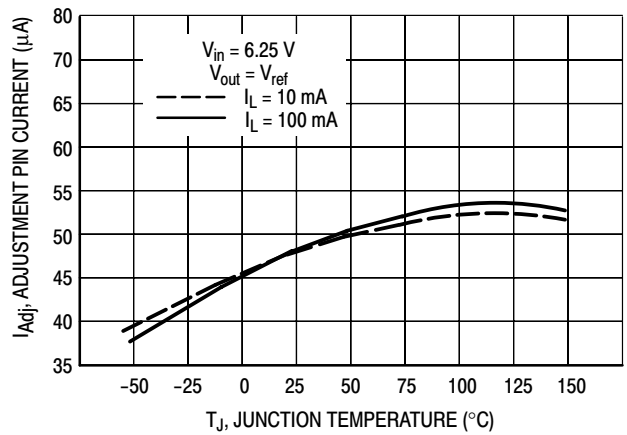

Figure 14. Adjustment Pin Current

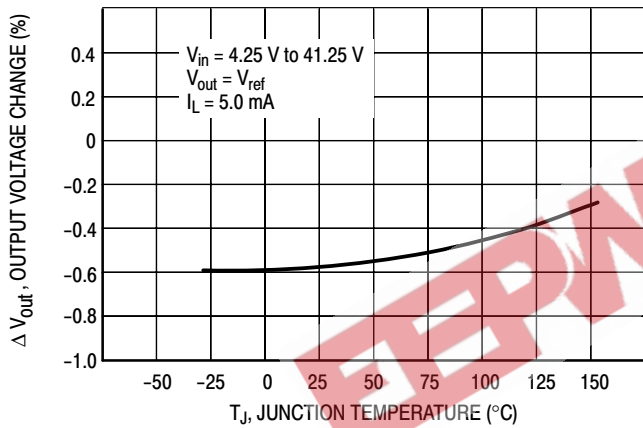

Figure 15. Line Regulation

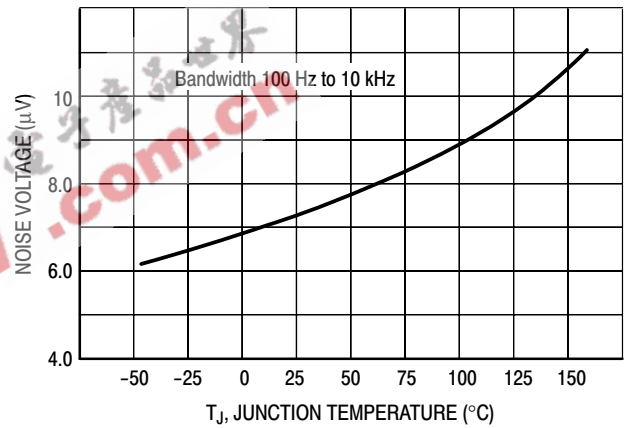

Figure 16. Output Noise

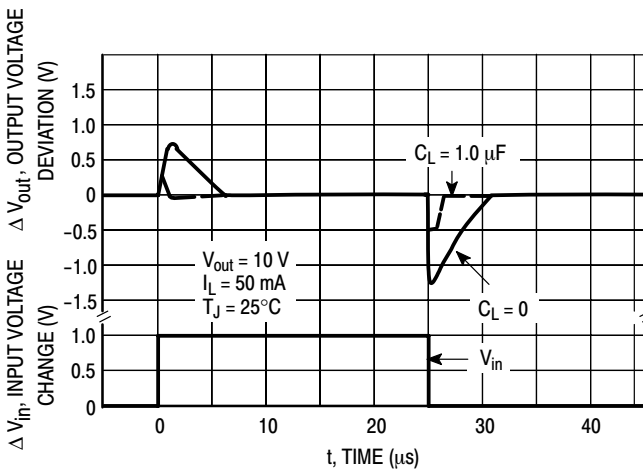

Figure 17. Line Transient Response

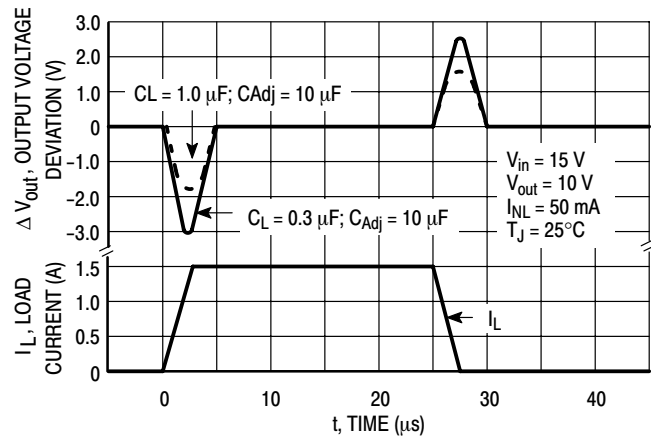

Figure 18. Load Transient Response

# LM317M

## APPLICATIONS INFORMATION

### Basic Circuit Operation

The LM317M is a three-terminal floating regulator. In operation, the LM317M develops and maintains a nominal 1.25 V reference ( $V_{ref}$ ) between its output and adjustment terminals. This reference voltage is converted to a programming current ( $I_{PROG}$ ) by  $R_1$  (see Figure 19), and this constant current flows through  $R_2$  to ground. The regulated output voltage is given by:

$$V_{out} = V_{ref} \left( 1 + \frac{R_2}{R_1} \right) + I_{Adj} R_2$$

Since the current from the terminal ( $I_{Adj}$ ) represents an error term in the equation, the LM317M was designed to control  $I_{Adj}$  to less than 100  $\mu A$  and keep it constant. To do this, all quiescent operating current is returned to the output terminal. This imposes the requirement for a minimum load current. If the load current is less than this minimum, the output voltage will rise.

Since the LM317M is a floating regulator, it is only the voltage differential across the circuit which is important to performance, and operation at high voltages with respect to ground is possible.

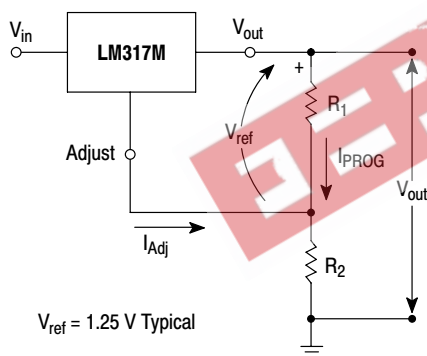

Figure 19. Basic Circuit Configuration

### Load Regulation

The LM317M is capable of providing extremely good load regulation, but a few precautions are needed to obtain maximum performance. For best performance, the programming resistor ( $R_1$ ) should be connected as close to the regulator as possible to minimize line drops which effectively appear in series with the reference, thereby degrading regulation. The ground end of  $R_2$  can be returned near the load ground to provide remote ground sensing and improve load regulation.

### External Capacitors

A 0.1  $\mu F$  disc or 1.0  $\mu F$  tantalum input bypass capacitor ( $C_{in}$ ) is recommended to reduce the sensitivity to input line impedance.

The adjustment terminal may be bypassed to ground to improve ripple rejection. This capacitor ( $C_{Adj}$ ) prevents ripple from being amplified as the output voltage is increased. A 10  $\mu F$  capacitor should improve ripple rejection about 15 dB at 120 Hz in a 10 V application.

Although the LM317M is stable with no output capacitance, like any feedback circuit, certain values of external capacitance can cause excessive ringing. An output capacitance ( $C_O$ ) in the form of a 1.0  $\mu F$  tantalum or 25  $\mu F$  aluminum electrolytic capacitor on the output swamps this effect and insures stability.

### Protection Diodes

When external capacitors are used with any IC regulator it is sometimes necessary to add protection diodes to prevent the capacitors from discharging through low current points into the regulator.

Figure 20 shows the LM317M with the recommended protection diodes for output voltages in excess of 25 V or high capacitance values ( $C_O > 25 \mu F$ ,  $C_{Adj} > 5.0 \mu F$ ). Diode  $D_1$  prevents  $C_O$  from discharging thru the IC during an input short circuit. Diode  $D_2$  protects against capacitor  $C_{Adj}$  discharging through the IC during an output short circuit. The combination of diodes  $D_1$  and  $D_2$  prevents  $C_{Adj}$  from discharging through the IC during an input short circuit.

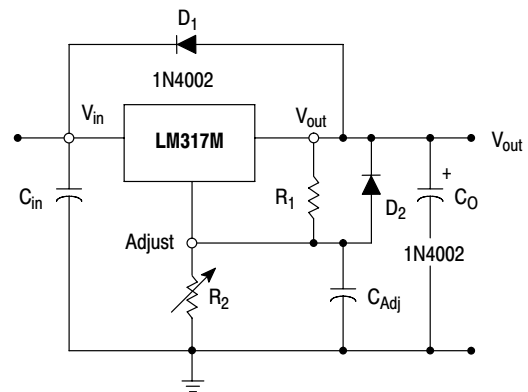

Figure 20. Voltage Regulator with Protection Diodes



## LM317M

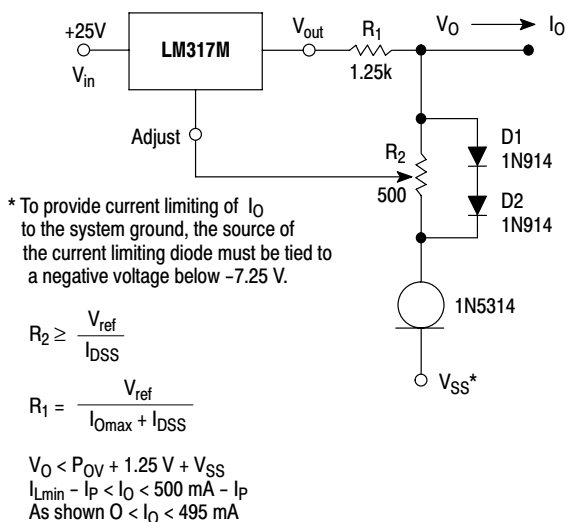
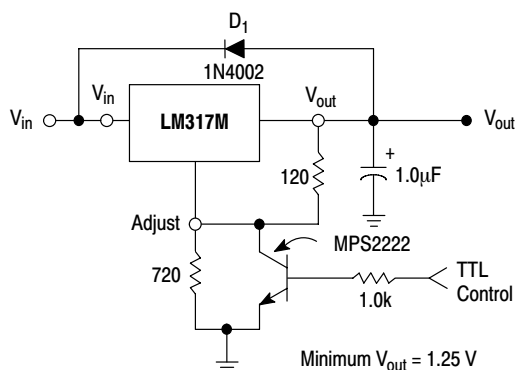

Figure 21. Adjustable Current Limiter



$D_1$  protects the device during an input short circuit.

Figure 22. 5 V Electronic Shutdown Regulator

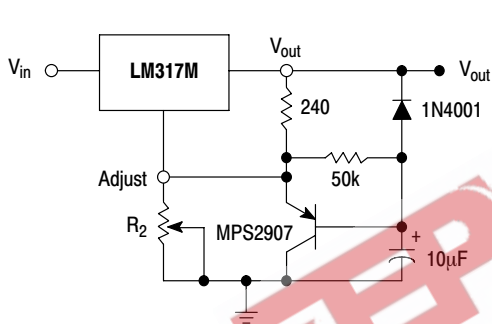

Figure 23. Slow Turn-On Regulator

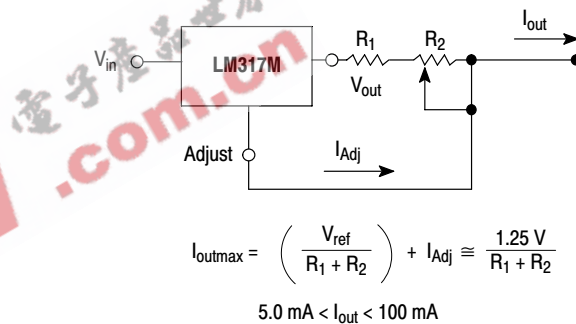
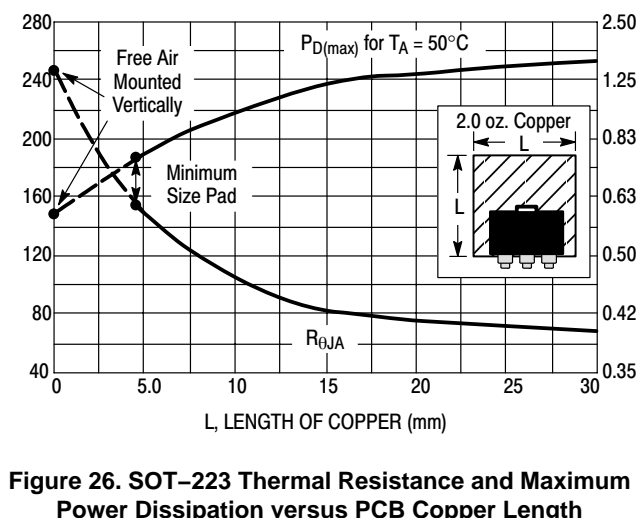
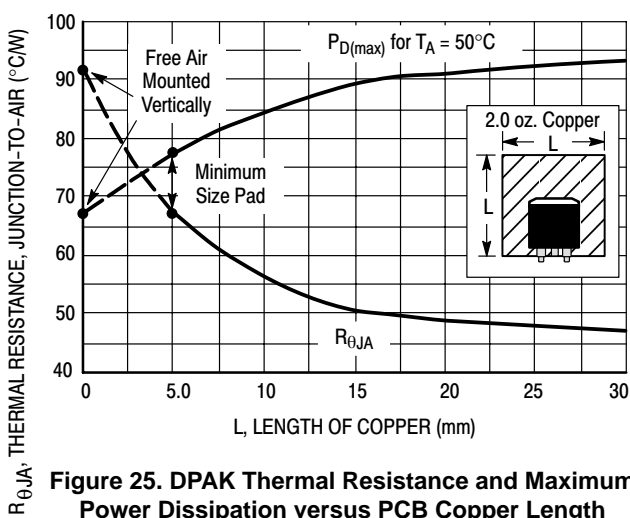

Figure 24. Current Regulator



## LM317M

### ORDERING INFORMATION

Device	Output Voltage Tolerance	Operating Temperature Range	Package	Shipping†
LM317MABDT	2%	$T_J = -40^{\circ}\text{C}$ to $125^{\circ}\text{C}$	DPAK	75 Units / Rail
LM317MABDTG			DPAK (Pb-Free)	75 Units / Rail
LM317MABDTRK			DPAK	2500 / Tape & Reel
LM317MABDTRKG			DPAK (Pb-Free)	2500 / Tape & Reel
LM317MABT			TO-220	50 Units / Rail
LM317MABTG			TO-220 (Pb-Free)	50 Units / Rail
LM317MADTRK		$T_J = 0^{\circ}\text{C}$ to $125^{\circ}\text{C}$	DPAK	2500 / Tape & Reel
LM317MADTRKG			DPAK (Pb-Free)	2500 / Tape & Reel
LM317MBDT	4%	$T_J = -40^{\circ}\text{C}$ to $125^{\circ}\text{C}$	DPAK	75 Units / Rail
LM317MBDTG			DPAK (Pb-Free)	75 Units / Rail
LM317MBDTRK			DPAK	2500 / Tape & Reel
LM317MBDTRKG			DPAK (Pb-Free)	2500 / Tape & Reel
LM317MBSTT3			SOT-223	4000 / Tape & Reel
LM317MBSTT3G			SOT-223 (Pb-Free)	4000 / Tape & Reel
LM317MBT			TO-220	50 Units / Rail
LM317MBTG			TO-220 (Pb-Free)	50 Units / Rail
LM317MDT		$T_J = 0^{\circ}\text{C}$ to $125^{\circ}\text{C}$	DPAK	75 Units / Rail
LM317MDTG			DPAK (Pb-Free)	75 Units / Rail
LM317MDTRK			DPAK	2500 / Tape & Reel
LM317MDTRKG			DPAK (Pb-Free)	2500 / Tape & Reel
LM317MSTT3			SOT-223	4000 / Tape & Reel
LM317MSTT3G			SOT-223 (Pb-Free)	4000 / Tape & Reel
LM317MT			TO-220	50 Units / Rail
LM317MTG			TO-220 (Pb-Free)	50 Units / Rail

†For information on tape and reel specifications, including part orientation and tape sizes, please refer to our Tape and Reel Packaging Specification Brochure, BRD8011/D.

# LM317M

## MARKING DIAGRAMS

### DPAK DT SUFFIX CASE 369C

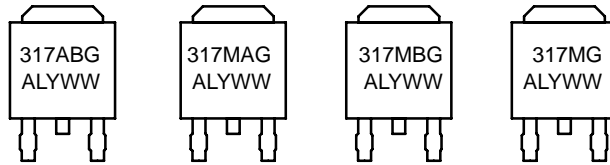

### TO-220 T SUFFIX CASE 221A

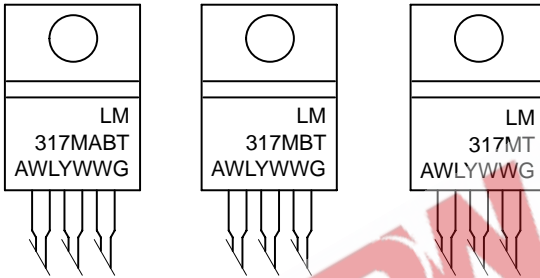

### SOT-223 ST SUFFIX CASE 318E

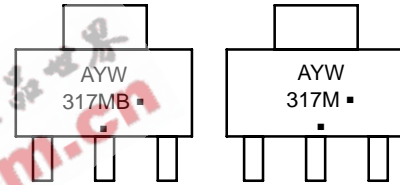

A = Assembly Location  
L, WL = Wafer Lot  
Y = Year  
WW, W = Work Week  
G or ■ = Pb-Free Package

(Note: Microdot may be in either location)

# LM317M

## PACKAGE DIMENSIONS

TO-220, SINGLE GAUGE  
T SUFFIX  
PLASTIC PACKAGE  
CASE 221AB-01  
ISSUE O

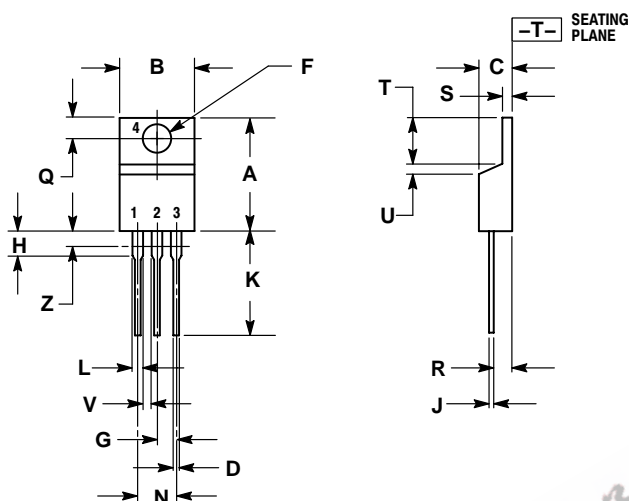

- NOTES:
1. DIMENSIONING AND TOLERANCING PER ANSI Y14.5M, 1982.
  2. CONTROLLING DIMENSION: INCH.
  3. DIMENSION Z DEFINES A ZONE WHERE ALL BODY AND LEAD IRREGULARITIES ARE ALLOWED.

DIM	INCHES		MILLIMETERS	
	MIN	MAX	MIN	MAX
A	0.570	0.620	14.48	15.75
B	0.380	0.405	9.66	10.28
C	0.160	0.190	4.07	4.82
D	0.025	0.035	0.64	0.88
F	0.142	0.147	3.61	3.73
G	0.095	0.105	2.42	2.66
H	0.110	0.155	2.80	3.93
J	0.018	0.025	0.46	0.64
K	0.500	0.562	12.70	14.27
L	0.045	0.060	1.15	1.52
N	0.190	0.210	4.83	5.33
Q	0.100	0.120	2.54	3.04
R	0.080	0.110	2.04	2.79
S	0.020	0.055	0.508	1.39
T	0.235	0.255	5.97	6.47
U	0.000	0.050	0.00	1.27
V	0.045	---	1.15	---
Z	---	0.080	---	2.04

DPAK  
DT SUFFIX  
PLASTIC PACKAGE  
CASE 369C-01  
ISSUE O

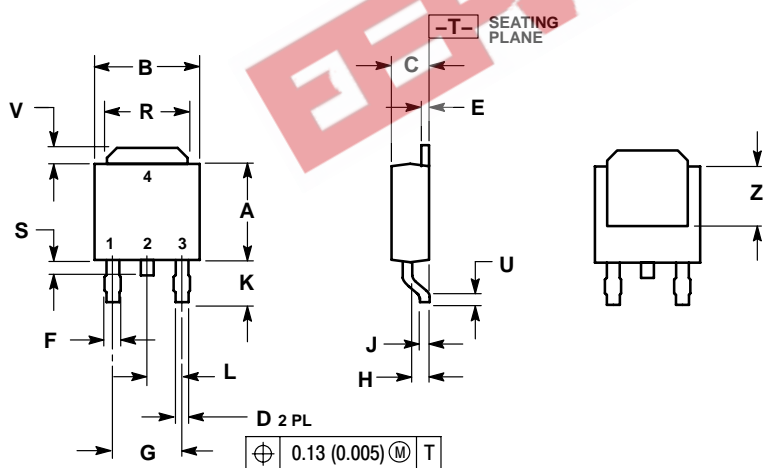

- NOTES:
1. DIMENSIONING AND TOLERANCING PER ANSI Y14.5M, 1982.
  2. CONTROLLING DIMENSION: INCH.

DIM	INCHES		MILLIMETERS	
	MIN	MAX	MIN	MAX
A	0.235	0.245	5.97	6.22
B	0.250	0.265	6.35	6.73
C	0.086	0.094	2.19	2.38
D	0.027	0.035	0.69	0.88
E	0.018	0.023	0.46	0.58
F	0.037	0.045	0.94	1.14
G	0.180 BSC		4.58 BSC	
H	0.034	0.040	0.87	1.01
J	0.018	0.023	0.46	0.58
K	0.102	0.114	2.60	2.89
L	0.090 BSC		2.29 BSC	
R	0.180	0.215	4.57	5.45
S	0.025	0.040	0.63	1.01
U	0.020	---	0.51	---
V	0.035	0.050	0.89	1.27
Z	0.155	---	3.93	---

### SOLDERING FOOTPRINT\*

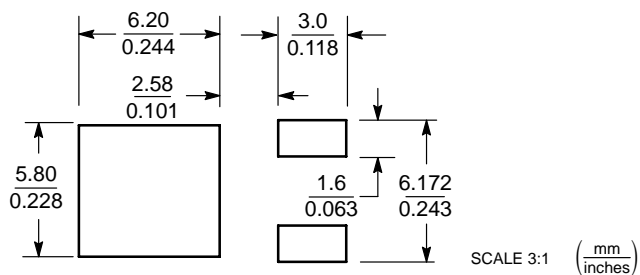

\*For additional information on our Pb-Free strategy and soldering details, please download the ON Semiconductor Soldering and Mounting Techniques Reference Manual, SOLDERRM/D.

# LM317M

## PACKAGE DIMENSIONS

SOT-223  
ST SUFFIX  
PLASTIC PACKAGE  
CASE 318E-04  
ISSUE L

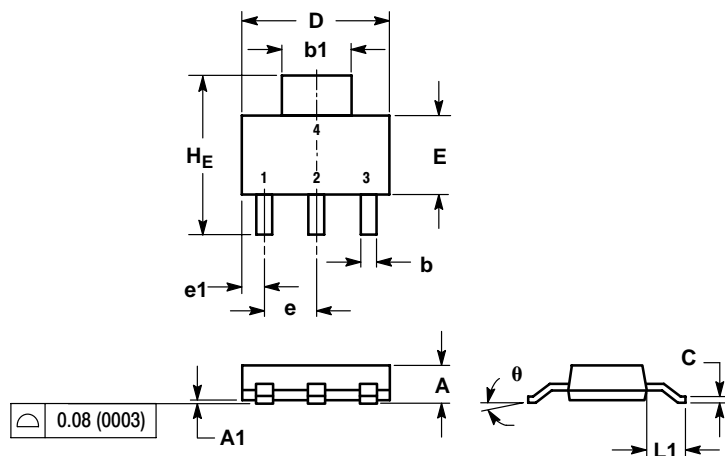

NOTES:  
1. DIMENSIONING AND TOLERANCING PER ANSI Y14.5M, 1982.  
2. CONTROLLING DIMENSION: INCH.

DIM	MILLIMETERS			INCHES		
	MIN	NOM	MAX	MIN	NOM	MAX
A	1.50	1.63	1.75	0.060	0.064	0.068
A1	0.02	0.06	0.10	0.001	0.002	0.004
b	0.60	0.75	0.89	0.024	0.030	0.035
b1	2.90	3.06	3.20	0.115	0.121	0.126
c	0.24	0.29	0.35	0.009	0.012	0.014
D	6.30	6.50	6.70	0.249	0.256	0.263
E	3.30	3.50	3.70	0.130	0.138	0.145
e	2.20	2.30	2.40	0.087	0.091	0.094
e1	0.85	0.94	1.05	0.033	0.037	0.041
L1	1.50	1.75	2.00	0.060	0.069	0.078
HE	6.70	7.00	7.30	0.264	0.276	0.287
θ	0°	-	10°	0°	-	10°

### SOLDERING FOOTPRINT\*

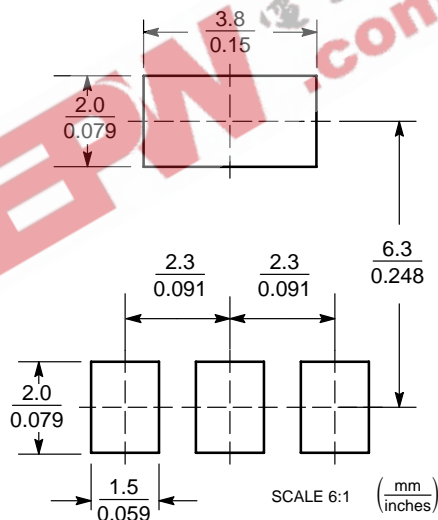

\*For additional information on our Pb-Free strategy and soldering details, please download the ON Semiconductor Soldering and Mounting Techniques Reference Manual, SOLDERRM/D.

ON Semiconductor and are registered trademarks of Semiconductor Components Industries, LLC (SCILLC). SCILLC reserves the right to make changes without further notice to any products herein. SCILLC makes no warranty, representation or guarantee regarding the suitability of its products for any particular purpose, nor does SCILLC assume any liability arising out of the application or use of any product or circuit, and specifically disclaims any and all liability, including without limitation special, consequential or incidental damages. "Typical" parameters which may be provided in SCILLC data sheets and/or specifications can and do vary in different applications and actual performance may vary over time. All operating parameters, including "Typicals" must be validated for each customer application by customer's technical experts. SCILLC does not convey any license under its patent rights nor the rights of others. SCILLC products are not designed, intended, or authorized for use as components in systems intended for surgical implant into the body, or other applications intended to support or sustain life, or for any other application in which the failure of the SCILLC product could create a situation where personal injury or death may occur. Should Buyer purchase or use SCILLC products for any such unintended or unauthorized application, Buyer shall indemnify and hold SCILLC and its officers, employees, subsidiaries, affiliates, and distributors harmless against all claims, costs, damages, and expenses, and reasonable attorney fees arising out of, directly or indirectly, any claim of personal injury or death associated with such unintended or unauthorized use, even if such claim alleges that SCILLC was negligent regarding the design or manufacture of the part. SCILLC is an Equal Opportunity/Affirmative Action Employer. This literature is subject to all applicable copyright laws and is not for resale in any manner.

### PUBLICATION ORDERING INFORMATION

LITERATURE FULFILLMENT:  
Literature Distribution Center for ON Semiconductor  
P.O. Box 5163, Denver, Colorado 80217 USA  
Phone: 303-675-2175 or 800-344-3860 Toll Free USA/Canada  
Fax: 303-675-2176 or 800-344-3867 Toll Free USA/Canada  
Email: orderlit@onsemi.com

N. American Technical Support: 800-282-9855 Toll Free  
USA/Canada  
Europe, Middle East and Africa Technical Support:  
Phone: 421 33 790 2910  
Japan Customer Focus Center  
Phone: 81-3-5773-3850

ON Semiconductor Website: [www.onsemi.com](http://www.onsemi.com)  
Order Literature: <http://www.onsemi.com/orderlit>

For additional information, please contact your local Sales Representative