



Quad Single Supply Comparators

These comparators are designed for use in level detection, low-level sensing and memory applications in consumer automotive and industrial electronic applications.

- Single or Split Supply Operation
- Low Input Bias Current: 25 nA (Typ)
- Low Input Offset Current: ± 5.0 nA (Typ)
- Low Input Offset Voltage: ± 1.0 mV (Typ) LM139A Series
- Input Common Mode Voltage Range to Gnd
- Low Output Saturation Voltage: 130 mV (Typ) @ 4.0 mA
- TTL and CMOS Compatible
- ESD Clamps on the Inputs Increase Reliability without Affecting Device Operation

MAXIMUM RATINGS

Rating	Symbol	Value	Unit
Power Supply Voltage LM239, A/LM339A/LM2901, V MC3302	V_{CC}	+36 or ± 18 +30 or ± 15	Vdc
Input Differential Voltage Range LM239, A/LM339A/LM2901, V MC3302	V_{IDR}	36 30	Vdc
Input Common Mode Voltage Range	V_{ICMR}	-0.3 to V_{CC}	Vdc
Output Short Circuit to Ground (Note 1)	I_{SC}	Continuous	
Power Dissipation @ $T_A = 25^\circ\text{C}$ Plastic Package Derate above 25°C	P_D	1.0 8.0	W mW/ $^\circ\text{C}$
Junction Temperature	T_J	150	$^\circ\text{C}$
Operating Ambient Temperature Range LM239, A MC3302 LM2901 LM2901V LM339, A	T_A	-25 to +85 -40 to +85 -40 to +105 -40 to +125 0 to +70	$^\circ\text{C}$
Storage Temperature Range	T_{stg}	-65 to +150	$^\circ\text{C}$

NOTE: 1. The maximum output current may be as high as 20 mA, independent of the magnitude of V_{CC} . Output short circuits to V_{CC} can cause excessive heating and eventual destruction.

Figure 1. Circuit Schematic

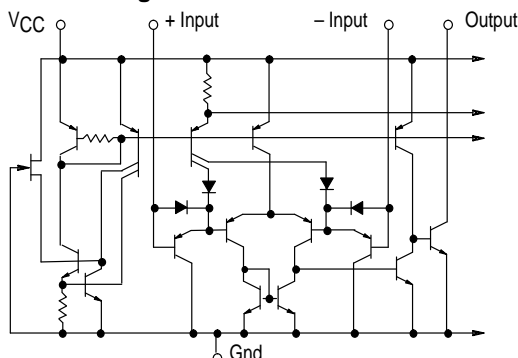

NOTE: Diagram shown is for 1 comparator.

LM339, LM339A, LM239, LM239A, LM2901, M2901V, MC3302

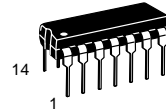

**N, P SUFFIX
PLASTIC PACKAGE
CASE 646**

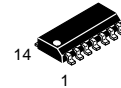

**D SUFFIX
PLASTIC PACKAGE
CASE 751A
(SO-14)**

PIN CONNECTIONS

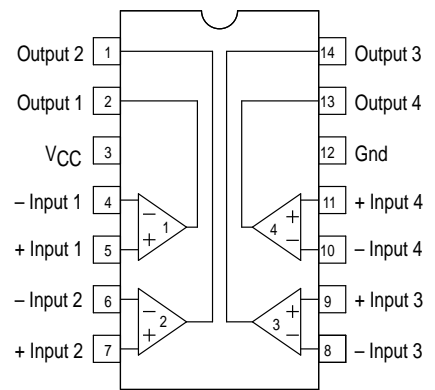

(Top View)

ORDERING INFORMATION

Device	Operating Temperature Range	Package
LM239D, AD LM239N, AN	$T_A = 25^\circ$ to $+85^\circ\text{C}$	SO-14 Plastic DIP
LM339D, AD LM339N, AN	$T_A = 0^\circ$ to $+70^\circ\text{C}$	SO-14 Plastic DIP
LM2901D LM2901N	$T_A = -40^\circ$ to $+105^\circ\text{C}$	SO-14 Plastic DIP
LM2901VD LM2901VN	$T_A = -40^\circ$ to $+125^\circ\text{C}$	SO-14 Plastic DIP
MC3302P	$T_A = -40^\circ$ to $+85^\circ\text{C}$	Plastic DIP

LM339, LM339A, LM239, LM239A, LM2901, M2901V, MC3302

ELECTRICAL CHARACTERISTICS (V_{CC} = +5.0 Vdc, T_A = +25°C, unless otherwise noted)

Characteristic	Symbol	LM239A/339A			LM239/339			LM2901/2901V			MC3302			Unit
		Min	Typ	Max	Min	Typ	Max	Min	Typ	Max	Min	Typ	Max	
Input Offset Voltage (Note 4)	V _{IO}	–	±1.0	±2.0	–	±2.0	±5.0	–	±2.0	±7.0	–	±3.0	±20	mVdc
Input Bias Current (Notes 4, 5) (Output in Analog Range)	I _{IB}	–	25	250	–	25	250	–	25	250	–	25	500	nA
Input Offset Current (Note 4)	I _{IO}	–	±5.0	±50	–	±5.0	±50	–	±5.0	±50	–	±3.0	±100	nA
Input Common Mode Voltage Range	V _{ICMR}	0	–	V _{CC} – 1.5	0	–	V _{CC} – 1.5	0	–	V _{CC} – 1.5	0	–	V _{CC} – 1.5	V
Supply Current R _L = ∞ (For All Comparators) R _L = ∞, V _{CC} = 30 Vdc	I _{CC}	–	0.8	2.0	–	0.8	2.0	–	0.8	2.0	–	0.8	2.0	mA
		–	1.0	2.5	–	1.0	2.5	–	1.0	2.5	–	1.0	2.5	
Voltage Gain R _L ≥ 15 kΩ, V _{CC} = 15 Vdc	A _{VOL}	50	200	–	50	200	–	25	100	–	25	100	–	V/mV
Large Signal Response Time V _I = TTL Logic Swing, V _{ref} = 1.4 Vdc, V _{RL} = 5.0 Vdc, R _L = 5.1 kΩ	–	–	300	–	–	300	–	–	300	–	–	300	–	ns
Response Time (Note 6) V _{RL} = 5.0 Vdc, R _L = 5.1 kΩ	–	–	1.3	–	–	1.3	–	–	1.3	–	–	1.3	–	μs
Output Sink Current V _I (–) ≥ +1.0 Vdc, V _I (+) = 0, V _O ≤ 1.5 Vdc	I _{Sink}	6.0	16	–	6.0	16	–	6.0	16	–	6.0	16	–	mA
Saturation Voltage V _I (–) ≥ +1.0 Vdc, V _I (+) = 0, I _{sink} ≤ 4.0 mA	V _{sat}	–	130	400	–	130	400	–	130	400	–	130	500	mV
Output Leakage Current V _I (+) ≥ +1.0 Vdc, V _I (–) = 0, V _O = +5.0 Vdc	I _{OL}	–	0.1	–	–	0.1	–	–	0.1	–	–	0.1	–	nA

PERFORMANCE CHARACTERISTICS (V_{CC} = +5.0 Vdc, T_A = T_{low} to T_{high} [Note 3])

Characteristic	Symbol	LM239A/339A			LM239/339			LM2901/2901V			MC3302			Unit
		Min	Typ	Max	Min	Typ	Max	Min	Typ	Max	Min	Typ	Max	
Input Offset Voltage (Note 4)	V _{IO}	–	–	±4.0	–	–	±9.0	–	–	±15	–	–	±40	mVdc
Input Bias Current (Notes 4, 5) (Output in Analog Range)	I _{IB}	–	–	400	–	–	400	–	–	500	–	–	1000	nA
Input Offset Current (Note 4)	I _{IO}	–	–	±150	–	–	±150	–	–	±200	–	–	±300	nA
Input Common Mode Voltage Range	V _{ICMR}	0	–	V _{CC} – 2.0	0	–	V _{CC} – 2.0	0	–	V _{CC} – 2.0	0	–	V _{CC} – 2.0	V
Saturation Voltage V _I (–) ≥ +1.0 Vdc, V _I (+) = 0, I _{sink} ≤ 4.0 mA	V _{sat}	–	–	700	–	–	700	–	–	700	–	–	700	mV
Output Leakage Current V _I (+) ≥ +1.0 Vdc, V _I (–) = 0, V _O = 30 Vdc	I _{OL}	–	–	1.0	–	–	1.0	–	–	1.0	–	–	1.0	μA
Differential Input Voltage All V _I ≥ 0 Vdc	V _{ID}	–	–	V _{CC}	–	–	V _{CC}	–	–	V _{CC}	–	–	V _{CC}	Vdc

NOTES: 3. (LM239/239A) T_{low} = –25°C, T_{high} = +85°C
 (LM339/339A) T_{low} = 0°C, T_{high} = +70°C
 (MC3302) T_{low} = –40°C, T_{high} = +85°C
 (LM2901) T_{low} = –40°C, T_{high} = +105°C
 (LM2901V) T_{low} = –40°C, T_{high} = +125°C

4. At the output switch point, V_O = 1.4 Vdc, R_S ≤ 100 Ω 5.0 Vdc ≤ V_{CC} ≤ 30 Vdc, with the inputs over the full common mode range (0 Vdc to V_{CC} – 1.5 Vdc).

5. The bias current flows out of the inputs due to the PNP input stage. This current is virtually constant, independent of the output state.

6. The response time specified is for a 100 mV input step with 5.0 mV overdrive. For larger signals, 300 ns is typical.

LM339, LM339A, LM239, LM239A, LM2901, M2901V, MC3302

Figure 2. Inverting Comparator with Hysteresis

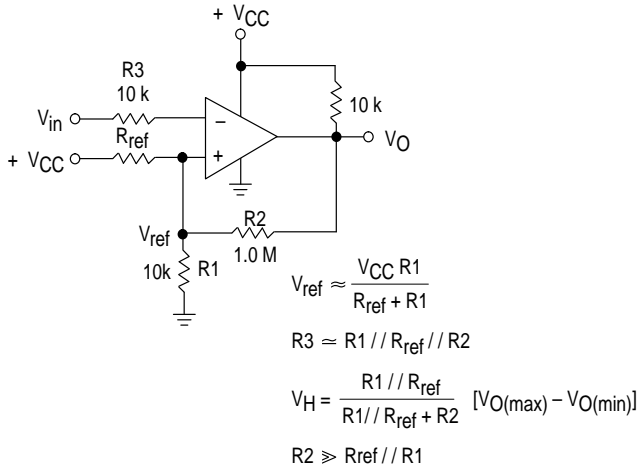
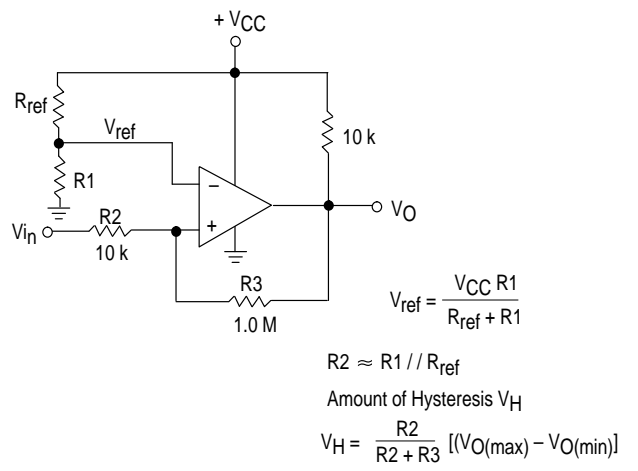

Figure 3. Noninverting Comparator with Hysteresis



Typical Characteristics

($V_{CC} = 15 \text{ Vdc}$, $T_A = +25^\circ\text{C}$ (each comparator) unless otherwise noted.)

Figure 4. Normalized Input Offset Voltage

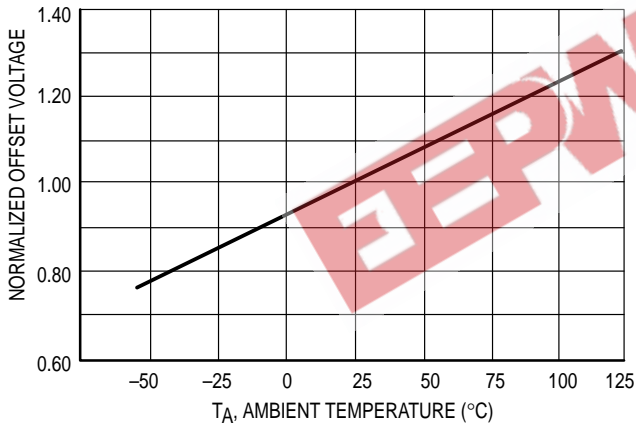

Figure 5. Input Bias Current

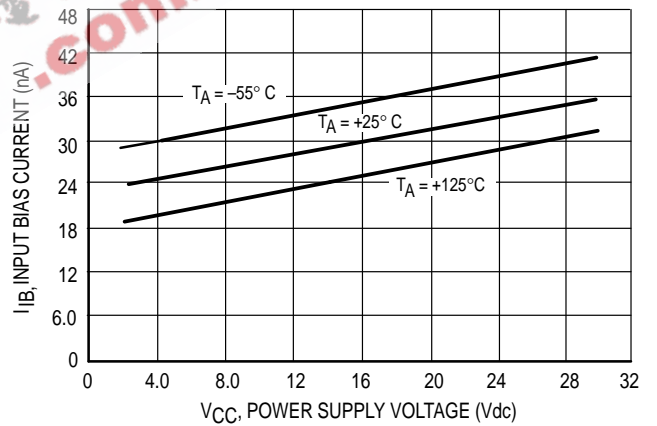
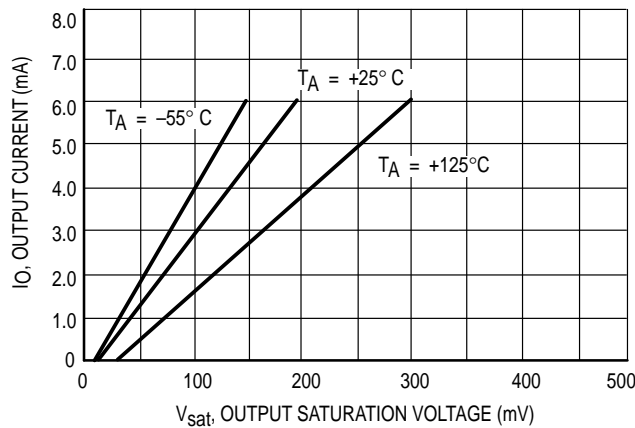
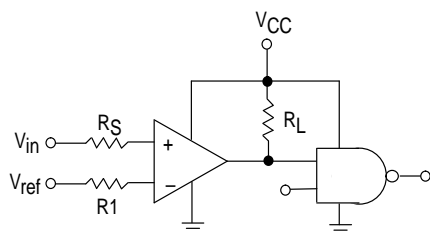

Figure 6. Output Sink Current versus Output Saturation Voltage



LM339, LM339A, LM239, LM239A, LM2901, M2901V, MC3302

Figure 7. Driving Logic



R_S = Source Resistance
 $R_1 \approx R_S$

Logic	Device	VCC (V)	RL kΩ
CMOS	1/4 MC14001	+15	100
TTL	1/4 MC7400	+5.0	10

Figure 8. Squarewave Oscillator

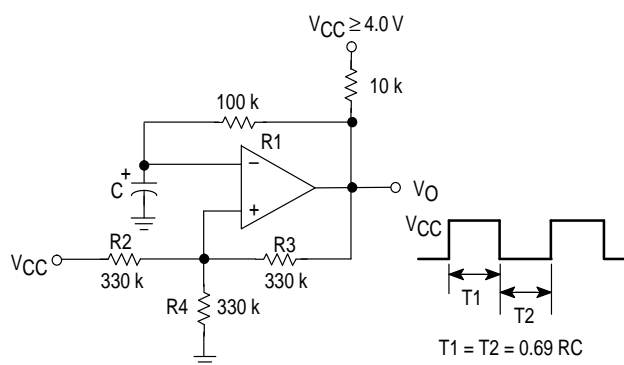

$$T_1 = T_2 = 0.69 RC$$

$$f \approx \frac{7.2}{C(\mu F)}$$

$$R_2 = R_3 = R_4$$

$$R_1 \approx R_2 // R_3 // R_4$$

APPLICATIONS INFORMATION

These quad comparators feature high gain, wide bandwidth characteristics. This gives the device oscillation tendencies if the outputs are capacitively coupled to the inputs via stray capacitance. This oscillation manifests itself during output transitions (V_{OL} to V_{OH}). To alleviate this situation input resistors $< 10 \text{ k}\Omega$ should be used. The addition

of positive feedback ($< 10 \text{ mV}$) is also recommended. It is good design practice to ground all unused input pins.

Differential input voltages may be larger than supply voltages without damaging the comparator's inputs. Voltages more negative than -300 mV should not be used.

Figure 9. Zero Crossing Detector (Single Supply)

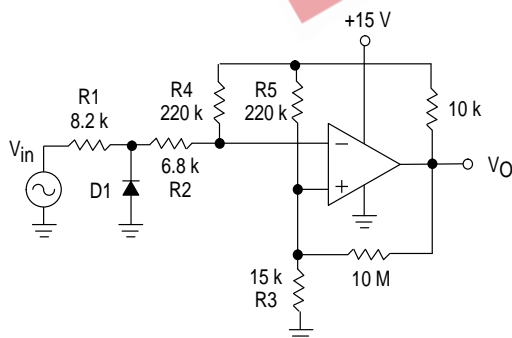

D1 prevents input from going negative by more than 0.6 V.

$$R_1 + R_2 = R_3$$

$$R_3 \leq \frac{R_5}{10} \text{ for small error in zero crossing}$$

Figure 10. Zero Crossing Detector (Split Supplies)

$V_{in(min)} \approx 0.4 \text{ V peak for } 1\% \text{ phase distortion } (\Delta\theta)$.

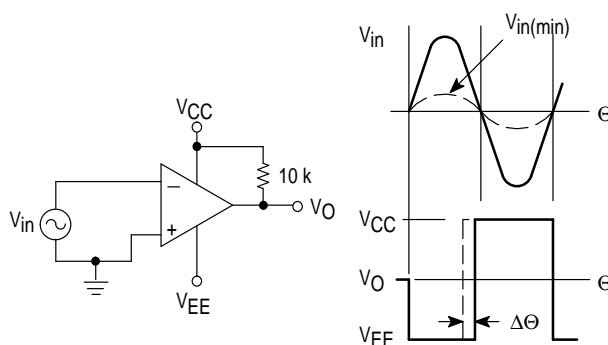

LM339, LM339A, LM239, LM239A, LM2901, M2901V, MC3302

OUTLINE DIMENSIONS

N, P SUFFIX PLASTIC PACKAGE CASE 646-06 ISSUE L

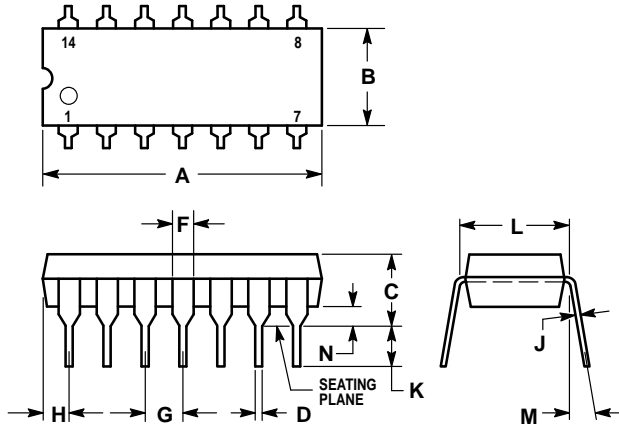

NOTES:

- LEADS WITHIN 0.13 (0.005) RADIUS OF TRUE POSITION AT SEATING PLANE AT MAXIMUM MATERIAL CONDITION.
- DIMENSION L TO CENTER OF LEADS WHEN FORMED PARALLEL.
- DIMENSION B DOES NOT INCLUDE MOLD FLASH.
- ROUNDED CORNERS OPTIONAL.

DIM	INCHES		MILLIMETERS	
	MIN	MAX	MIN	MAX
A	0.715	0.770	18.16	19.56
B	0.240	0.260	6.10	6.60
C	0.145	0.185	3.69	4.69
D	0.015	0.021	0.38	0.53
F	0.040	0.070	1.02	1.78
G	0.100 BSC		2.54 BSC	
H	0.052	0.095	1.32	2.41
J	0.008	0.015	0.20	0.38
K	0.115	0.135	2.92	3.43
L	0.300 BSC		7.62 BSC	
M	0°	10°	0°	10°
N	0.015	0.039	0.39	1.01

D SUFFIX PLASTIC PACKAGE CASE 751A-03 (SO-14) ISSUE F

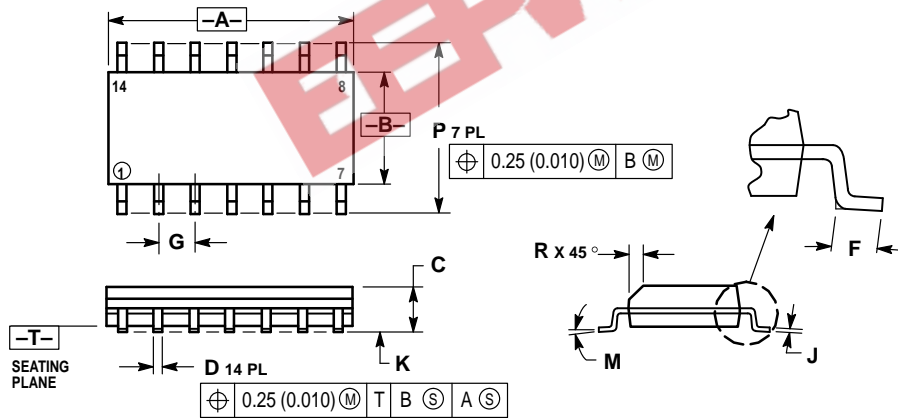

NOTES:

- DIMENSIONING AND TOLERANCING PER ANSI Y14.5M, 1982.
- CONTROLLING DIMENSION: MILLIMETER.
- DIMENSIONS A AND B DO NOT INCLUDE MOLD PROTRUSION.
- MAXIMUM MOLD PROTRUSION 0.15 (0.006) PER SIDE.
- DIMENSION D DOES NOT INCLUDE DAMBAR PROTRUSION. ALLOWABLE DAMBAR PROTRUSION SHALL BE 0.127 (0.005) TOTAL IN EXCESS OF THE D DIMENSION AT MAXIMUM MATERIAL CONDITION.

DIM	MILLIMETERS		INCHES	
	MIN	MAX	MIN	MAX
A	8.55	8.75	0.337	0.344
B	3.80	4.00	0.150	0.157
C	1.35	1.75	0.054	0.068
D	0.35	0.49	0.014	0.019
F	0.40	1.25	0.016	0.049
G	1.27 BSC		0.050 BSC	
J	0.19	0.25	0.008	0.009
K	0.10	0.25	0.004	0.009
M	0°	7°	0°	7°
P	5.80	6.20	0.228	0.244
R	0.25	0.50	0.010	0.019

LM339, LM339A, LM239, LM239A, LM2901, M2901V, MC3302

EEPW 电子产品世界
.com.cn

Motorola reserves the right to make changes without further notice to any products herein. Motorola makes no warranty, representation or guarantee regarding the suitability of its products for any particular purpose, nor does Motorola assume any liability arising out of the application or use of any product or circuit, and specifically disclaims any and all liability, including without limitation consequential or incidental damages. "Typical" parameters which may be provided in Motorola data sheets and/or specifications can and do vary in different applications and actual performance may vary over time. All operating parameters, including "Typicals" must be validated for each customer application by customer's technical experts. Motorola does not convey any license under its patent rights nor the rights of others. Motorola products are not designed, intended, or authorized for use as components in systems intended for surgical implant into the body, or other applications intended to support or sustain life, or for any other application in which the failure of the Motorola product could create a situation where personal injury or death may occur. Should Buyer purchase or use Motorola products for any such unintended or unauthorized application, Buyer shall indemnify and hold Motorola and its officers, employees, subsidiaries, affiliates, and distributors harmless against all claims, costs, damages, and expenses, and reasonable attorney fees arising out of, directly or indirectly, any claim of personal injury or death associated with such unintended or unauthorized use, even if such claim alleges that Motorola was negligent regarding the design or manufacture of the part. Motorola and  are registered trademarks of Motorola, Inc. Motorola, Inc. is an Equal Opportunity/Affirmative Action Employer.

How to reach us:

USA/EUROPE/Locations Not Listed: Motorola Literature Distribution;
P.O. Box 20912; Phoenix, Arizona 85036. 1-800-441-2447 or 602-303-5454

MFAX: RMFAX0@email.sps.mot.com – TOUCHTONE 602-244-6609
INTERNET: <http://Design-NET.com>

JAPAN: Nippon Motorola Ltd.; Tatsumi-SPD-JLDC, 6F Seibu-Butsuryu-Center,
3-14-2 Tatsumi Koto-Ku, Tokyo 135, Japan. 03-81-3521-8315

ASIA/PACIFIC: Motorola Semiconductors H.K. Ltd.; 8B Tai Ping Industrial Park,
51 Ting Kok Road, Tai Po, N.T., Hong Kong. 852-26629298



MOTOROLA



LM339/D

