

THREE-TERMINAL 3A-5V POSITIVE VOLTAGE REGULATORS

- OUTPUT CURRENT : 3A
- INTERNAL CURRENT AND THERMAL LIMITING
- TYPICAL OUTPUT IMPEDANCE : 0.01Ω
- MINIMUM INPUT VOLTAGE : 7.5V
- POWER DISSIPATION : 30W

DESCRIPTION

The LM123, LM223, LM323 are three-terminal positive voltage regulators with a preset 5V output and a load driving capability of 3A. New circuit design and processing techniques are used to provide the high output current without sacrificing the regulation characteristics of lower current devices.

The 3A regulator is virtually blowout proof.

Current limiting, power limiting and thermal shut-down provide the same high level of reliability obtained with these techniques in the LM209, 1A regulator.

An overall worst case specification for the combined effects of input voltage, load current, ambient temperature, and power dissipation ensure that the LM123, LM223, LM323 will perform satisfactorily as a system element.

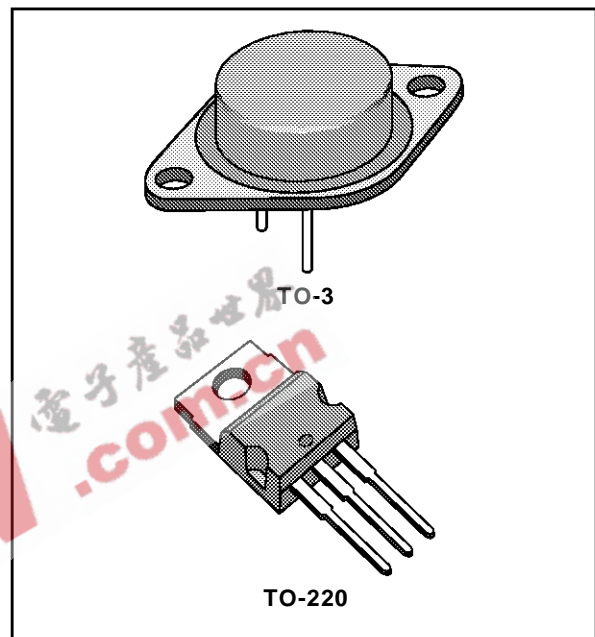

ORDER CODES

Part Number	Temperature Range	Package	
		K	T
LM123	-55 °C to 150 °C	•	
LM223	-25 °C to 150 °C	•	
LM323	0 °C to 125 °C	•	•

PIN CONNECTION

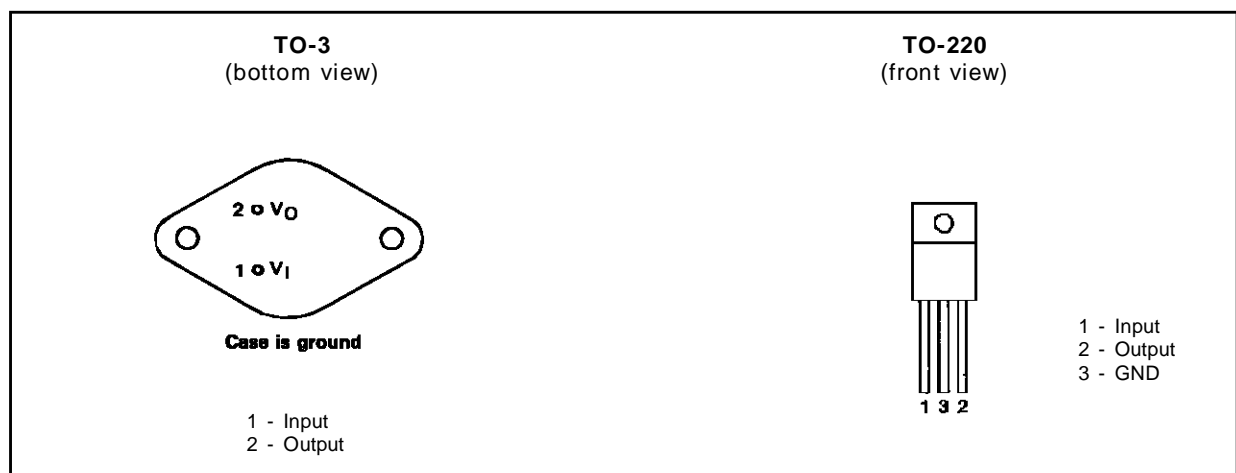

LM123-LM223-LM323

ABSOLUTE MAXIMUM RATING

Symbol	Parameter	Value	Unit
V_i	Input Voltage	20	V
I_o	Output Current	Internally Limited	
P_{tot}	Power Dissipation	Internally Limited	
T_{oper}	Operating Junction Temperature Range	LM123	-55 to 150
		LM223	-25 to 150
		LM323	0 to 125
T_{stg}	Storage Temperature Range	-65 to 150	°C

THERMAL CHARACTERISTICS

Symbol	Parameter	Typ.	Max.	Unit
$R_{thj-case}$	Junction-case Thermal Resistance	TO-3	2	°C/W
		TO-220	3	
$R_{thj-amb}$	Junction-ambient Thermal Resistance	TO-3	35	°C/W
		TO-220	50	

SCHEMATIC DIAGRAM

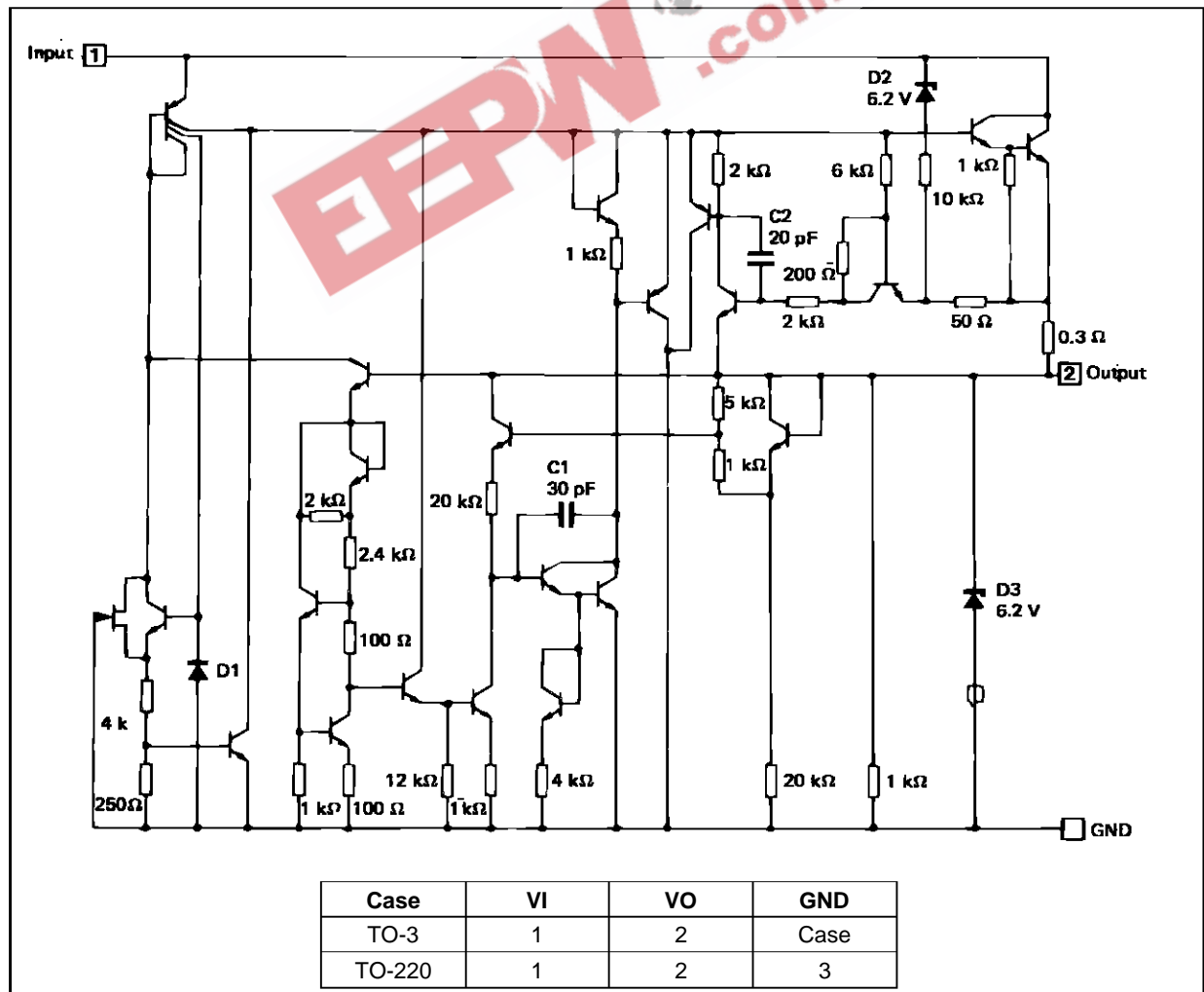

ELECTRICAL CHARACTERISTICS

LM123: $-55\text{ }^{\circ}\text{C} < T_j < 150\text{ }^{\circ}\text{C}$

LM223: $-25\text{ }^{\circ}\text{C} < T_j < 150\text{ }^{\circ}\text{C}$

LM323: $0\text{ }^{\circ}\text{C} < T_j < 150\text{ }^{\circ}\text{C}$

Symbol	Parameter	LM123/LM223			LM323			Unit
		Min.	Typ.	Max.	Min.	Typ.	Max.	
V_O	Output Voltage Range (Note 2) $T_{amb} = 25\text{ }^{\circ}\text{C}$, $V_I = 7.5\text{ V}$, $I_O = 0$	4.7	5	5.3	4.8	5	5.2	V
V_O	Output Voltage Range (Note 2) $T_{min} \leq T_j \leq T_{max}$, $P \leq P_{max}$ $7.5\text{ V} \leq V_I \leq 15\text{ V}$, $0 \leq I_O \leq 3\text{ A}$	4.6		5.4	4.75		5.25	V
K_{VI}	Line Regulation (Note 3) $T_j = 25\text{ }^{\circ}\text{C}$, $7.5\text{ V} \leq V_I \leq 15\text{ V}$		5	25		5	25	mV
K_{VO}	Load Regulation (Note 3) $T_j = 25\text{ }^{\circ}\text{C}$, $V_I = 7.5\text{ V}$, $0 \leq I_O \leq 3\text{ A}$		25	100		25	100	mV
I_{IB}	Quiescent Current $7.5\text{ V} \leq V_I \leq 15\text{ V}$, $0 \leq I_O \leq 3\text{ A}$		12	20		12	20	mA
V_{NO}	Output Noise Voltage $T_{amb} = 25\text{ }^{\circ}\text{C}$, $10\text{ Hz} \leq f \leq 100\text{ KHz}$		40			40		μV_{rms}
I_{OS}	Short Circuit Current Limit ($T_j = 25\text{ }^{\circ}\text{C}$) $V_I = 15\text{ V}$ $V_I = 7.5\text{ V}$		3 4	4.5 5		3 4	4.5 5	A
K_{VH}	Long Term Stability			35			35	mV

- Notes :**
1. Although power dissipation is internally limited, specifications apply only for $P \leq 30\text{ W}$.
 2. Selected devices with tightened tolerance output voltage available.
 3. Load and line regulation are specified at constant junction temperature. Pulse testing is required with a pulse width $\leq 1\text{ ms}$ and a duty cycle $\leq 5\%$.

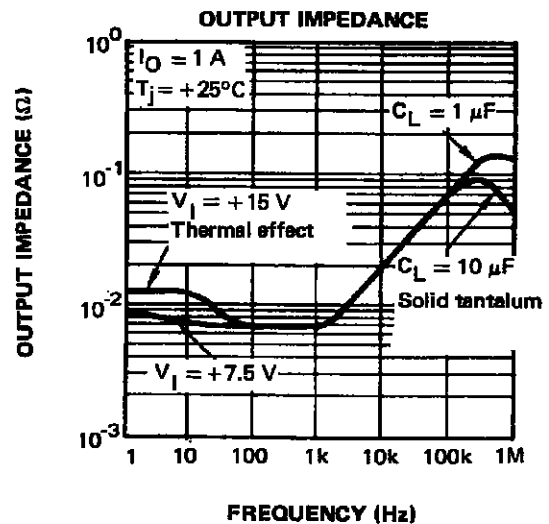
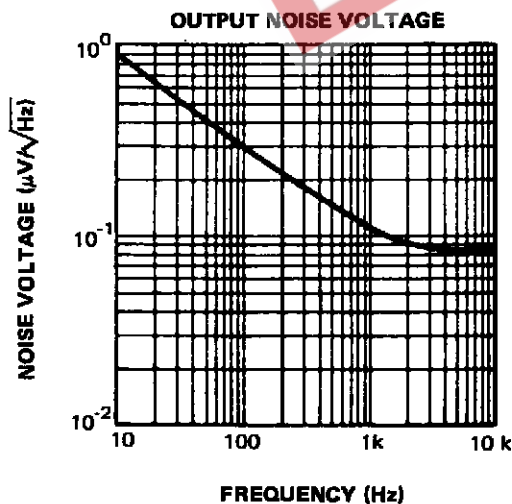

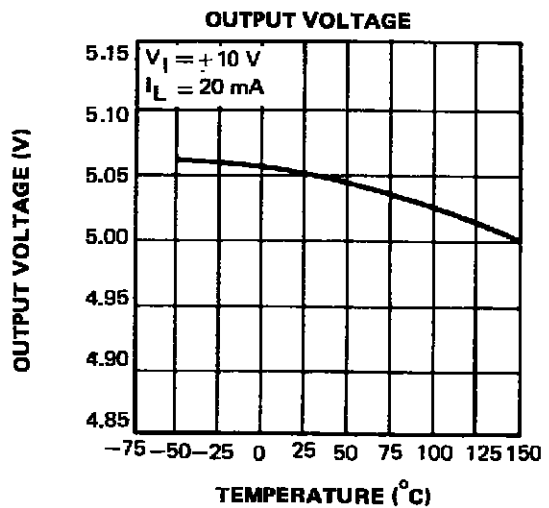
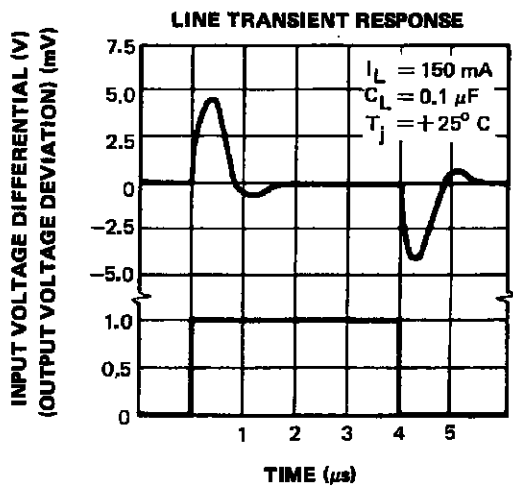
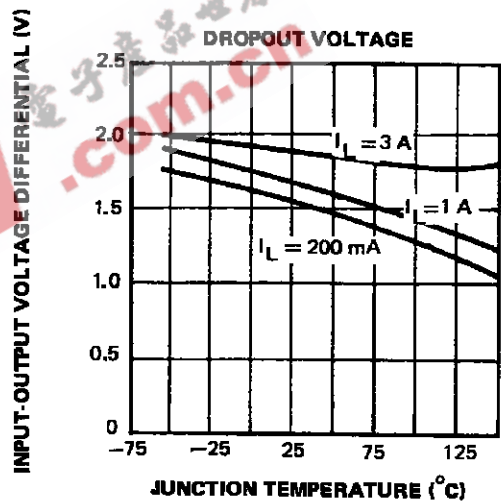
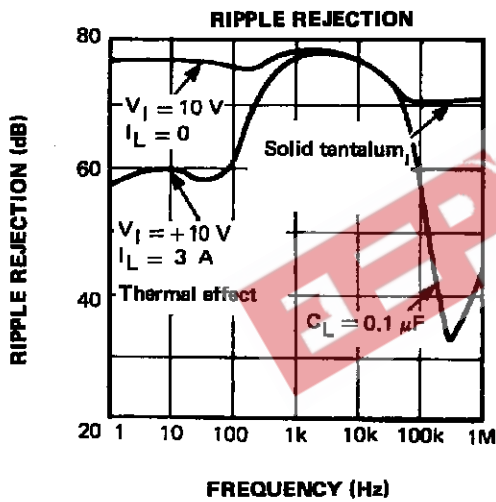
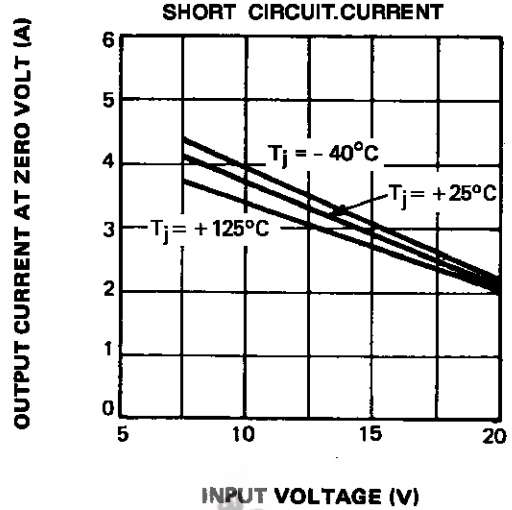
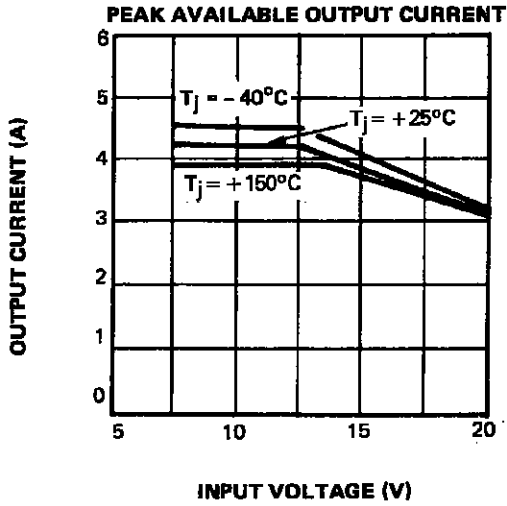

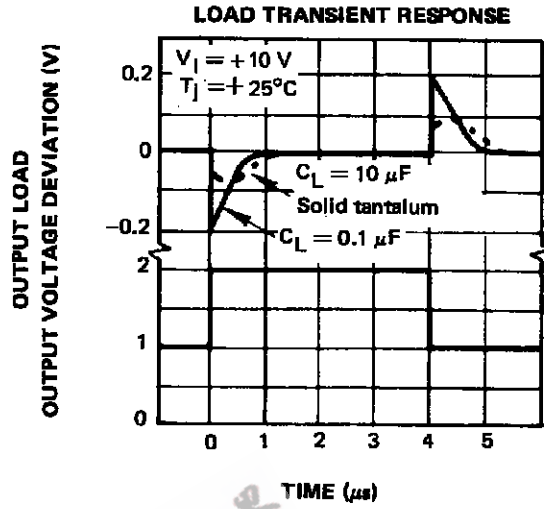
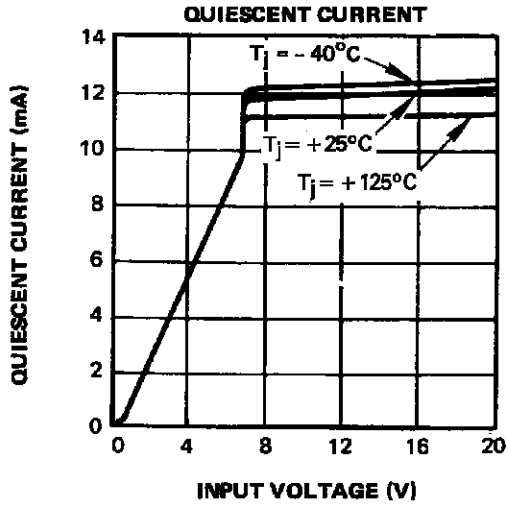

TYPICAL APPLICATIONS

BASIC 3A REGULATOR

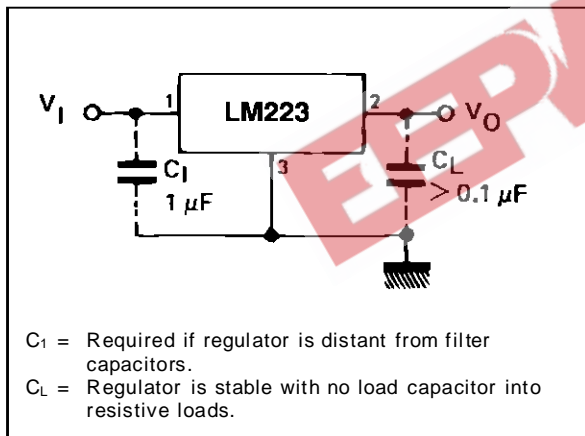

TRIMMING OUTPUT TO 5V

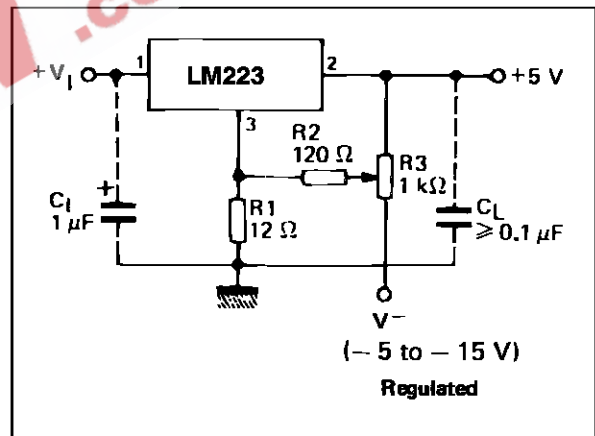

LM123-LM223-LM323

10A REGULATOR WITH COMPLETE OVERLOAD PROTECTION

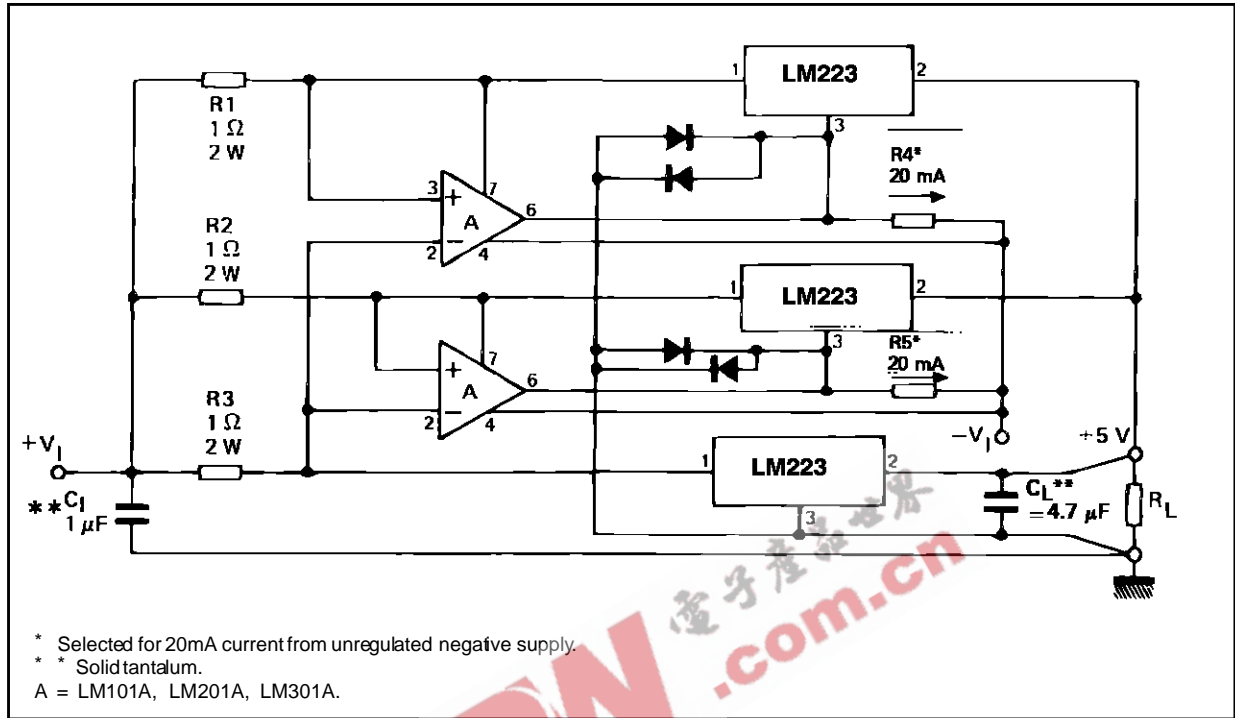

ADJUSTABLE REGULATOR 0 - 10V/3A

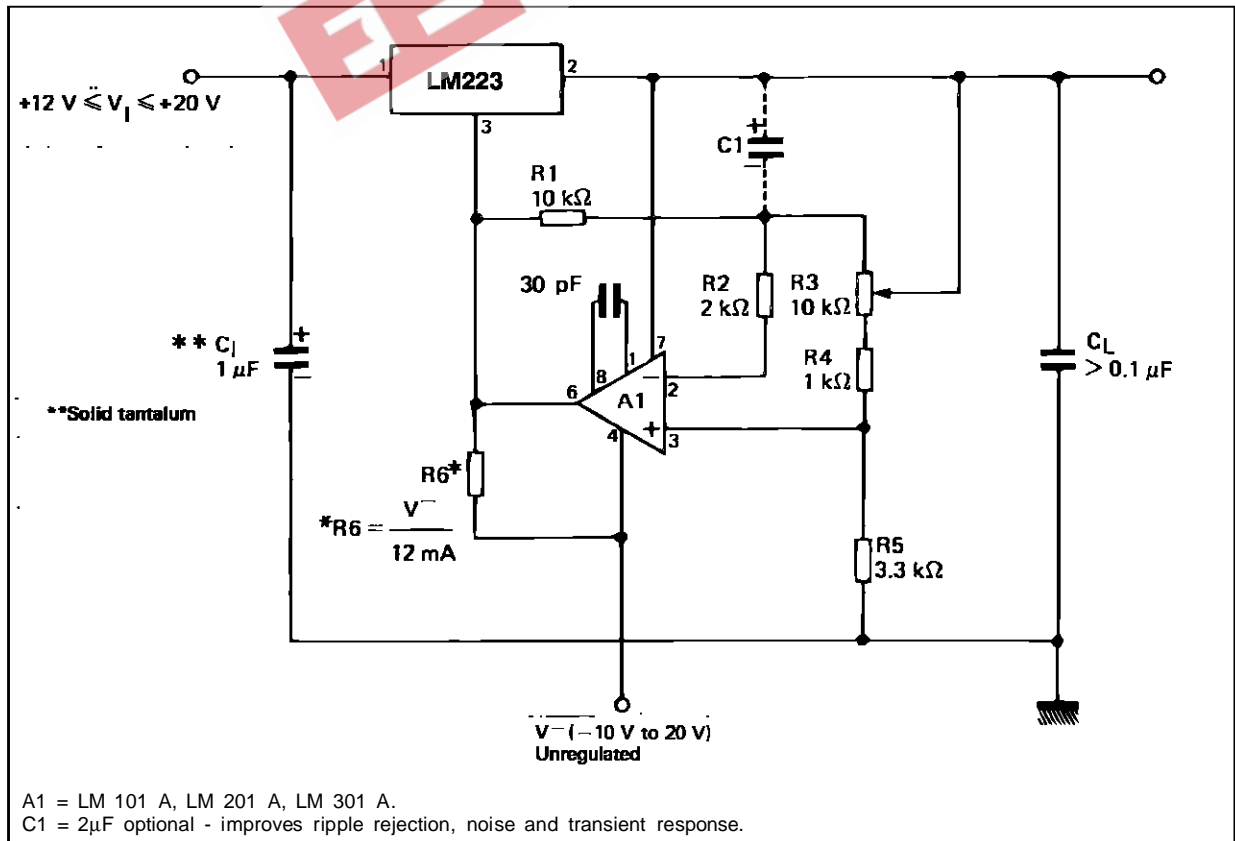

TO-3 MECHANICAL DATA

DIM.	mm			inch		
	MIN.	TYP.	MAX.	MIN.	TYP.	MAX.
A	11.00		13.10	0.433		0.516
B	0.97		1.15	0.038		0.045
C	1.50		1.65	0.059		0.065
D	8.32		8.92	0.327		0.351
E	19.00		20.00	0.748		0.787
G	10.70		11.10	0.421		0.437
N	16.50		17.20	0.649		0.677
P	25.00		26.00	0.984		1.023
R	4.00		4.09	0.157		0.161
U	38.50		39.30	1.515		1.547
V	30.00		30.30	1.187		1.193

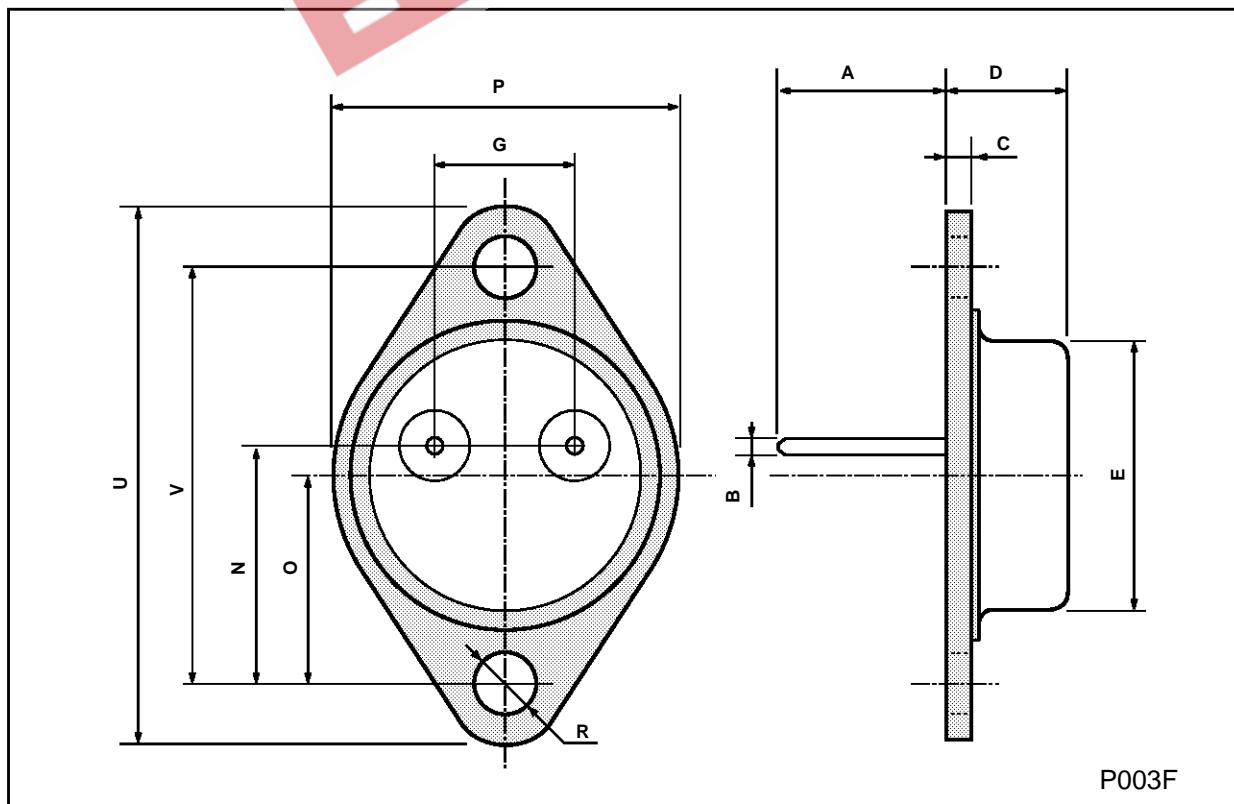

TO-220 MECHANICAL DATA

DIM.	mm			inch		
	MIN.	TYP.	MAX.	MIN.	TYP.	MAX.
A	4.40		4.60	0.173		0.181
C	1.23		1.32	0.048		0.051
D	2.40		2.72	0.094		0.107
D1		1.27			0.050	
E	0.49		0.70	0.019		0.027
F	0.61		0.88	0.024		0.034
F1	1.14		1.70	0.044		0.067
F2	1.14		1.70	0.044		0.067
G	4.95		5.15	0.194		0.203
G1	2.4		2.7	0.094		0.106
H2	10.0		10.40	0.393		0.409
L2		16.4			0.645	
L4	13.0		14.0	0.511		0.551
L5	2.65		2.95	0.104		0.116
L6	15.2		15.9	0.598		0.625
L7	6.2		6.6	0.244		0.260
L9	3.5		4.2	0.137		0.165
DIA.	3.75		3.85	0.147		0.151

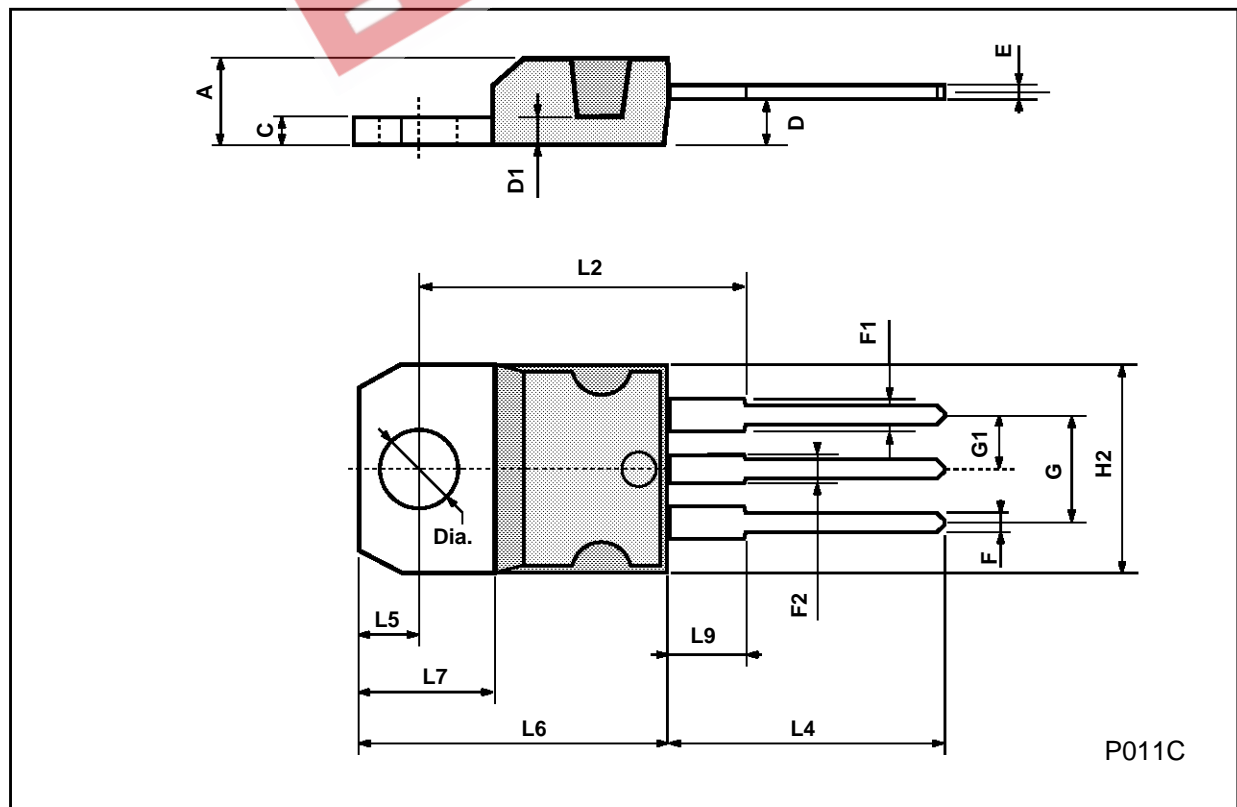

EEPW 电子產品世界
.com.cn

Information furnished is believed to be accurate and reliable. However, SGS-THOMSON Microelectronics assumes no responsibility for the consequences of use of such information nor for any infringement of patents or other rights of third parties which may result from its use. No license is granted by implication or otherwise under any patent or patent rights of SGS-THOMSON Microelectronics. Specifications mentioned in this publication are subject to change without notice. This publication supersedes and replaces all information previously supplied. SGS-THOMSON Microelectronics products are not authorized for use as critical components in life support devices or systems without express written approval of SGS-THOMSON Microelectronics.

© 1994 SGS-THOMSON Microelectronics - All Rights Reserved

SGS-THOMSON Microelectronics GROUP OF COMPANIES

Australia - Brazil - France - Germany - Hong Kong - Italy - Japan - Korea - Malaysia - Malta - Morocco - The Netherlands -
Singapore - Spain - Sweden - Switzerland - Taiwan - Thailand - United Kingdom - U.S.A