

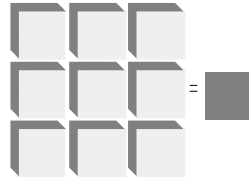

LSI/CSI



LS7534 LS7535

LSI Computer Systems, Inc. 1235 Walt Whitman Road, Melville, NY 11747 (631) 271-0400 FAX (631) 271-0405

DIMMER LIGHT SWITCH WITH UP AND DOWN CONTROLS

August 1996

FEATURES:

- Phase-lock loop synchronization allows use as a Wall Switch
- Brightness control of incandescent lamps with touch plates (LS7534) or mechanical switches (LS7535)
- Dual Controls eliminate confusion
- Soft turn-on /turn-off
- Controls the "Duty Cycle" from 23% to 88% (conduction angles for AC half-cycles between 41° and 159°, respectively)
- Operates at 50Hz/60Hz line frequency
- Input for slow dimming
- +12V to +18V DC supply voltage (Vss - VDD)
- LS7534/LS7535 (DIP);
LS7534-S/LS7535-S SOIC - See Figure 1

CONNECTION DIAGRAM - TOP VIEW

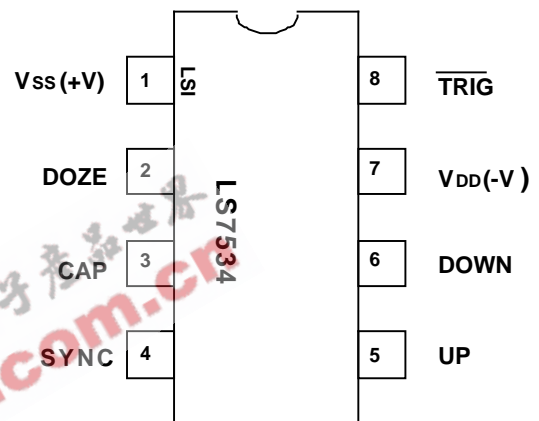

FIGURE 1

DESCRIPTION:

LS7534/LS7535 are monolithic, MOS integrated circuits that are designed for brightness control of incandescent lamps. The outputs of these ICs control the brightness of a lamp by controlling the firing angle of a triac connected in series with the lamp. All internal timings are synchronized with the line frequency by means of a built-in phase-lock loop circuit. The output occurs once every half-cycle of the line frequency. Within the half-cycle, the output can be positioned anywhere between 159° conduction angle for maximum brightness and 41° conduction angle for minimum brightness in relation to the AC line frequency. The positioning of the output is controlled by applying the proper logic levels at the UP and DOWN inputs.

These functions may be implemented with very few interface components which is described in the application examples (See Fig. 5A and 5B). For touch plates, LS7534 is used (Fig. 5A). For mechanical switches, LS7535 is used (Fig. 5B).

In the following Operating Description of the application examples, an Activation is Touch for LS7534 and Switch Closure for LS7535.

Short Activation (34ms to 325ms)

UP - When the lamp is off, if a short activation is applied to the UP input, the lamp brightness is ramped up to full-on or to a previous brightness stored in the memory. The ramp-up time from off to full-on is 2.8 sec. The ramp-up time from off to any other brightness is proportionally shorter. When the lamp is on at any brightness, a short activation applied to the UP input has no effect.

DOWN - If a short activation is applied to the DOWN input, the lamp brightness is ramped down to off. The ramp-down time from full-on to off is 5.6 seconds. The ramp-down time from any other brightness is proportionally shorter. When the lamp is off, a short activation applied to the DOWN input has no effect.

Long Activation (Greater than 334ms)

UP - If a long activation is applied to the UP input, the lamp brightness ramps up from the pre-activation brightness as long as the activation is maintained or until the full brightness is reached. At full brightness any continued long activation has no further effect.

DOWN - If a long activation is applied to the DOWN input, the lamp brightness is ramped down as long as the long activation is maintained or until the minimum brightness is reached. At minimum brightness, any continued long activation has no further effect. When the lamp is off, a long activation applied to the DOWN input has no effect.

TABLE 1

UP/DOWN SIGNAL DURATION

INPUT	SHORT 34ms to 325 ms		LONG More than 334ms	
	PRE-ACTIVATION BRIGHTNESS	POST-ACTIVATION BRIGHTNESS	PRE-ACTIVATION BRIGHTNESS	POST-ACTIVATION BRIGHTNESS
UP	Off	Memory ** (See Note 1)	Off	Increases from Min.
	Max.	No Change	Max.	No change
	Intermediate	No Change	Intermediate	Increases from pre-touch brightness
DOWN	Off	No Change	Off	No change
	Max.	Off *	Max.	Decreases from Max.
	Intermediate	Off *	Intermediate	Decreases from pre-touch brightness

* 5.6 second ramp-down from max. to off. Ramp-down time from any other brightness is proportionally shorter.

** 2.8 second ramp-up from off to max.

NOTE 1: "Memory" refers to the brightness stored in the memory. The brightness is stored in memory when the lamp is turned off by a short activation. First time after power-up, a short activation produces max. brightness.

INPUT/OUTPUT DESCRIPTION:

Vss (Pin 1)

Supply voltage positive terminal.

DOZE (Pin 2)

A clock applied to this input causes the brightness to decrease in equal increments with each negative transition of the clock. Eventually, when the lamp becomes off, this input has no further effect. The lamp can be turned on again by activating the UP input. For the transition from maximum brightness to off, a total of 83 clock pulses are needed at the DOZE input.

When either the UP or the DOWN input is active, the DOZE input is disabled.

CAP (Pin 3)

The CAP input is for external component connection for the PLL filter capacitor. A capacitor of 0.047µF ± 20% should be used at this input.

SYNC (Pin 4).

The AC line frequency (50Hz/60Hz), when applied to this input, synchronizes all internal timings through a phase lock loop. The signal for this input may be obtained from the line voltage by employing the circuit arrangement shown in the application examples.

UP (Pin 5).

This input controls the turn-on and the conduction angle, ϕ , of the TRIG output. A description of this is provided in the DESCRIPTION and TABLE 1. For LS7534, a logic low level is the active level whereas for LS7535 a logic high level is the active level. LS7535 has an internal pull-down resistor of about 500K Ohms on this input.

DOWN (Pin 6).

This input controls the turn-off and the conduction angle, ϕ , of the TRIG output. A description of this is provided in the DESCRIPTION and TABLE 1. For LS7534, a logic low level is the active level, whereas for LS7535 a logic high level is the active level. LS7535 has an internal pull-down resistor of about 500K Ohms on this input.

VDD (Pin 7).

Supply voltage negative terminal.

TRIG (Pin 8).

The TRIG output provides a low level pulse occurring every half-cycle of the SYNC signal. The conduction angle, ϕ , of the TRIG output can be varied within the range of 41° to 159° by means of either the UP or the DOWN input.

ABSOLUTE MAXIMUM RATINGS:

PARAMETER	SYMBOL	VALUE	UNIT
DC supply voltage	$V_{SS} - V_{DD}$	+20	V
Any input voltage	V_{IN}	$V_{SS} - 20$ to $V_{SS} + 0.5$	V
Operating temperature	T_A	0 to +80	°C
Storage temperature	T_{STG}	-65 to +150	°C

DC ELECTRICAL CHARACTERISTICS:

(TA = 25°C, all voltages referenced to VDD)

PARAMETER	SYMBOL	MIN	TYP	MAX	UNIT	CONDITIONS
Supply voltage	V_{SS}	+12	-	+18	V	-
Supply current	I_{SS}	-	1.2	1.7	mA	$V_{SS} = +15V$, Output off

Input Voltages:

DOZE LO	V_{IZL}	0	-	$V_{SS} - 6$	V	-
DOZE HI	V_{IZH}	$V_{SS} - 2$	-	V_{SS}	V	-
SYNC LO	V_{IRL}	0	-	$V_{SS} - 9.5$	V	-
SYNC HI	V_{IRH}	$V_{SS} - 5.5$	-	V_{SS}	V	-
UP, DOWN LO	V_{IOL}	0	-	$V_{SS} - 8$	V	-
UP, DOWN HI	V_{IOH}	$V_{SS} - 2$	-	V_{SS}	V	-

Input Current:

SYNC, UP, DOWN HI	I_{IH}	-	-	110	µA	With Series 1.5M Resistor to 115 VAC Line
SYNC, UP, DOWN LO	I_{IL}	-	-	100	nA	-
DOZE HI	I_{IH}	-	-	100	nA	-
DOZE LO	I_{IL}	-	-	100	nA	-
\overline{TRIG} HI	V_{OH}	-	V_{SS}	-	V	-
\overline{TRIG} LO	V_{OL}	-	$V_{SS} - 8$	-	V	$V_{SS} = +15V$
\overline{TRIG} Sink Current	I_{OS}	50	-	-	mA	$V_{SS} = +15V$, $V_{OL} = V_{SS} - 4V$

TRANSIENT CHARACTERISTICS (See Fig. 2 and 3)(All timings are based on $f_s = 60Hz$, unless otherwise specified.)

PARAMETER	SYMBOL	MIN	TYP	MAX	UNIT
SYNC frequency	f_s	40	-	70	Hz
UP, DOWN duration (SHORT)	T_{s1}	34	-	325	ms
UP, DOWN duration (LONG)	T_{s2}	334	-	infinite	ms
∅ ramp time, off to max (UP,SHORT)	T_{US}	-	2.8	-	sec
∅ ramp time, min to max (UP, LONG)	T_{UL}	-	3.6	-	sec
∅ ramp time, max to min (DOWN,SHORT)	T_{DS}	-	5.6	-	sec
∅ ramp time, max to min (DOWN, LONG)	T_{DL}	-	3.6	-	sec
\overline{TRIG} pulse width	T_W	-	33	-	µs
\overline{TRIG} conduction angle (See Note)	∅	41	-	159	degrees
DOZE frequency	f_D	0	-	500	Hz

NOTE: The phase delay caused by the typical RC network used between SYNC input and the AC line (See Fig. 5A and Fig. 5B) reduces the effective ∅ values by 8°.

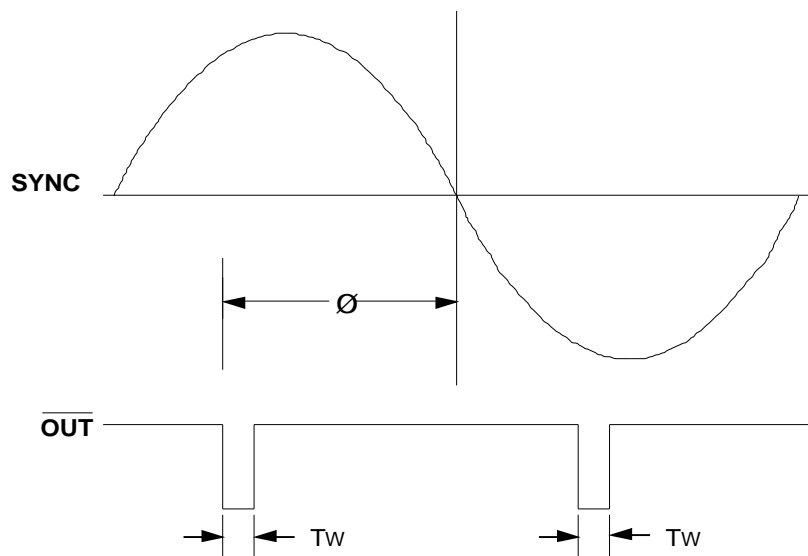

FIGURE 2. OUTPUT CONDUCTION ANGLE, \varnothing

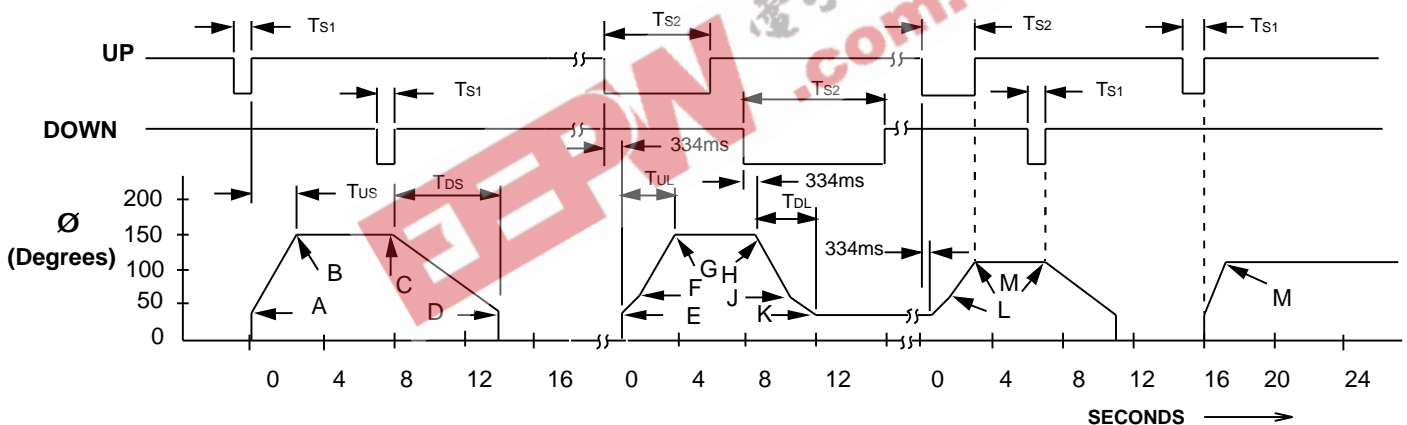
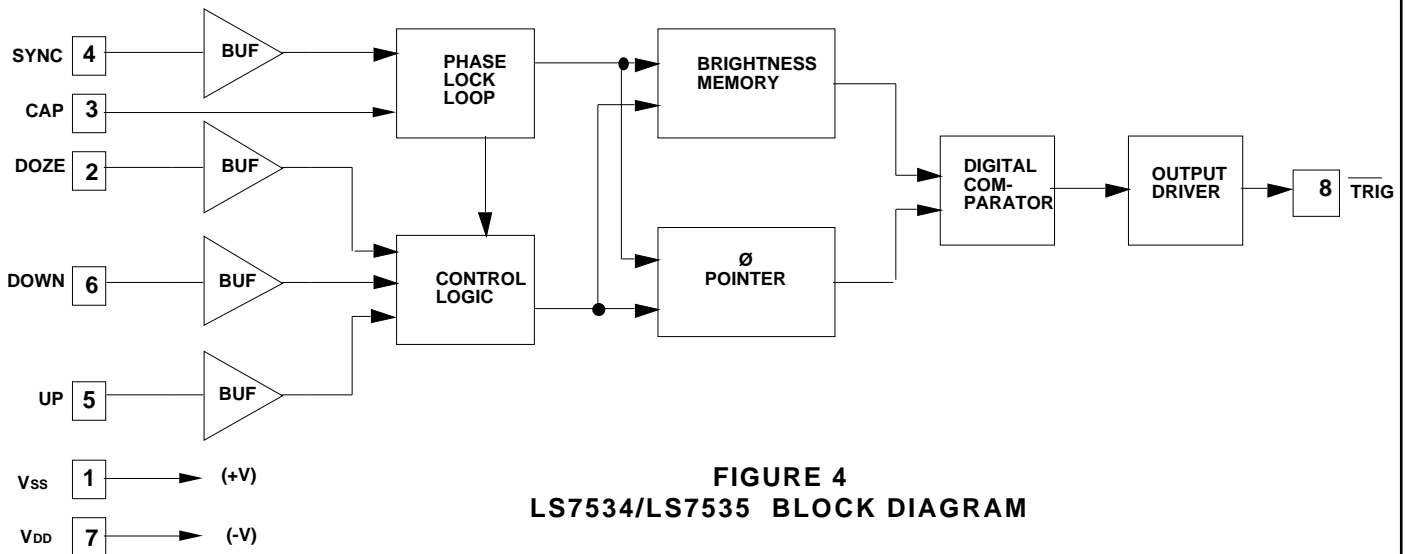

FIGURE 3. OUTPUT CONDUCTION ANGLE, \varnothing , vs UP/DOWN INPUTS

Note 1. UP/DOWN input polarity shown is for LS7534. For LS7535, the polarity is reversed.

Note 2. Points A, D, E and K correspond to minimum brightness, where $\varnothing = 41^\circ$.
Points B, C, G and H correspond to maximum brightness, where $\varnothing = 159^\circ$.
Points denoted by M correspond to an arbitrary intermediate brightness.

Note 3. Points F, J and L correspond to $\varnothing = 64^\circ$. The ramp-up or ramp-down rate of \varnothing changes at these points (upon long activation only) indicated by the discontinuity of the slopes. The interval E to F or J to K, in terms of time and angle, are 934ms and 23° , respectively.



APPLICATION EXAMPLES:

Typical dimmer light switch circuit schematics are shown in Fig. 5A (LS7534) and Fig. 5B (LS7535). The brightness of the lamp is set by touching the UP and DOWN touch plates in Fig. 5A and closure of the UP and DOWN switches in Fig. 5B. The functions of different components are as follows:

- Z, D1, R1, C2 and C5 produce the 15V DC supply for the chip.
- R2 and C4 filter and current limit the AC signal for the SYNC input.
- C3 is the filter capacitor for the internal PLL.
- C1 and L are RFI filters.
- In Fig. 5A, R3 and R4 set the touch sensitivity of the UP and DOWN inputs.
- In Fig. 5B, R3 limits the current between Vss and the UP and DOWN inputs upon closure of a switch.
- The resistor and diode connected between the chip output and the triac gate provides current limiting and isolation for the chip. The resistor is R5 in Fig. 5A and R4 in Fig. 5B.
- In Fig. 5B, PCB layout may cause triac switching transients to be coupled to the UP or Down input which can have the effect of having a Long switch closure “lock-up” at a certain phase angle output. In this case, capacitors C6 and C7 must be added as shown.

The information included herein is believed to be accurate and reliable. However, LSI Computer Systems, Inc. assumes no responsibilities for inaccuracies, nor for any infringements of patent rights of others which may result from its use.

FIGURE 5A. TYPICAL LS7534 DIMMER LIGHT SWITCH

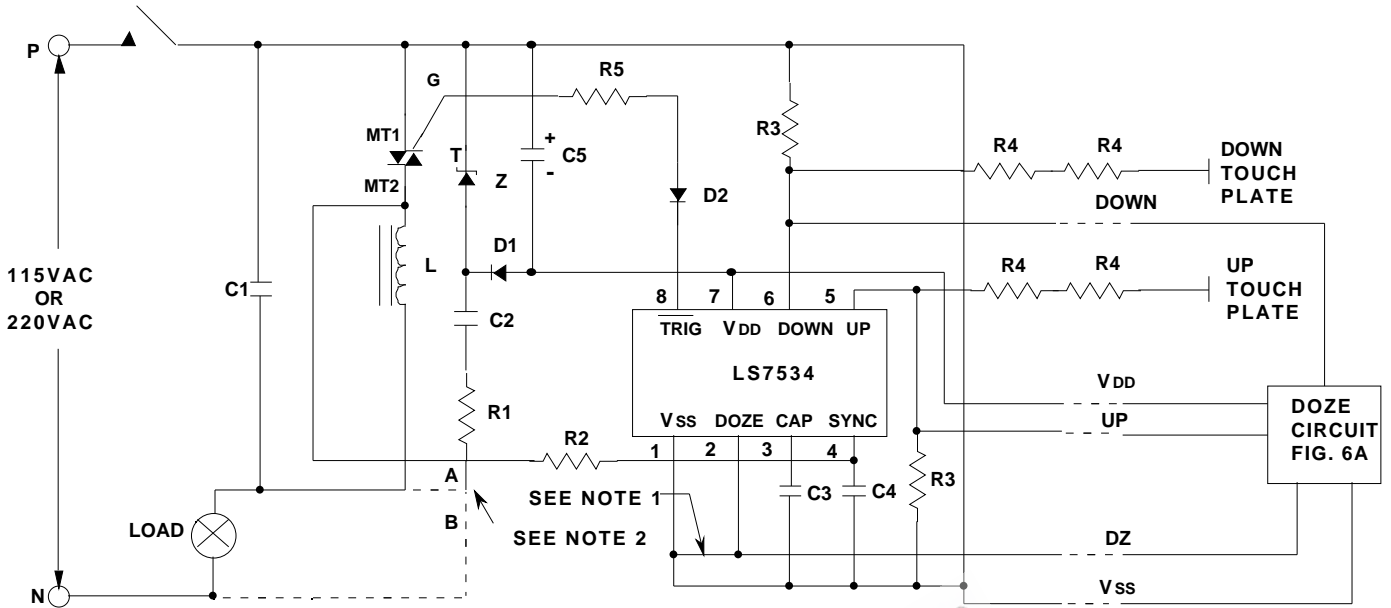

- NOTES:** 1) When DOZE circuit is used, break Pin 1 to Pin 2 connection.
 2) Use Connection A when Neutral is not available. Use Connection B when Neutral is available.

115VAC

- | | |
|---|------------------------------|
| C1 = 0.15 μ F, 200V | R4 = 2.7M Ω , 1/4W |
| C2 = See C2 Value Table | R5 = See R5 Value Table |
| C3 = 0.047 μ F, 25V | D1, D2 = IN4148 |
| C4 = 470pF, 25V | Z = 15V, 1W (Zener) |
| C5 = 47 μ F, 25V | T = Q4004L4 Triac (Typical) |
| (1) R1 = 270 Ω , 1W | L = 100 μ H (RFI Filter) |
| R2 = 1.5M Ω , 1/4W | |
| R3 = 1M Ω to 5M Ω , 1/4W (Select for sensitivity) | |

(1) For Connection A. Use 1/4 W for Connection B.

C2 VALUE TABLE

C2 = 0.33 μ F, 200V, Connection A

R5 VALUE TABLE

R5 = 100 Ω , 1/4W, 25mA Triac Gate

220VAC

- | | |
|---|------------------------------|
| C1 = 0.15 μ F, 400V | R4 = 4.7M Ω , 1/4W |
| C2 = See C2 Value Table | R5 = See R5 Value Table |
| C3 = 0.047 μ F, 25V | D1, D2 = IN4148 |
| C4 = 470pF, 25V | Z = 15V, 1W (Zener) |
| C5 = 47 μ F, 25V | T = Q5004L4 Triac (Typical) |
| (2) R1 = 1k Ω , 2W | L = 200 μ H (RFI Filter) |
| R2 = 1.5M Ω , 1/4W | |
| R3 = 1M Ω to 5M Ω , 1/4W (Select for sensitivity) | |

(2) For Connection A. Use 1/4W for Connection B.

C2 VALUE TABLE

C2 = 0.22 μ F, 400V, Connection A
 C2 = 0.10 μ F, 400V, Connection B

R5 VALUE TABLE

R5 = 100 Ω , 1/4W, 25mA Triac Gate
 R5 = 50 Ω , 1/4W, 50mA Triac Gate

FIGURE 5B. TYPICAL LS7535 DIMMER LIGHT SWITCH

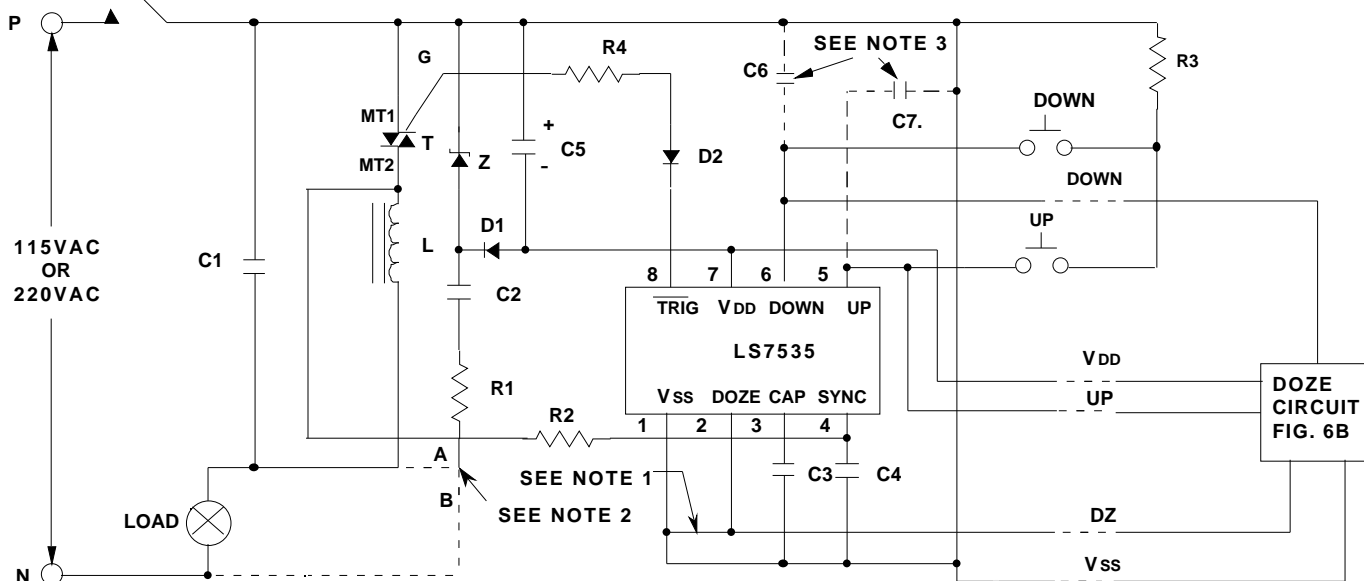

- NOTES:** 1) When DOZE circuit is used, break Pin 1 to Pin 2 connection.
 2) Use Connection A when Neutral is not available. Use Connection B when Neutral is available.
 3) C6 and C7 may be required in some PCB layouts to eliminate coupling from triac circuitry.

115VAC

- | | |
|-----------------------------|------------------------------|
| C1 = 0.15 μ F, 200V | R2 = 1.5M , 1/4W |
| C2 = See C2 Value Table | R3 = 27k , 1/4W |
| C3 = 0.047 μ F, 25V | R4 = See R4 Value Table |
| C4 = 470pF, 25V | D1, D2 = IN4148 |
| C5 = 47 μ F, 25V | Z = 15V, 1W (Zener) |
| C6, C7 = 0.001 μ F, 25V | T = Q4004L4 Triac (Typical) |
| (1) R1 = 270 , 1W | L = 100 μ H (RFI Filter) |

(1) For Connection A. Use 1/4W for Connection B.

C2 VALUE TABLE

- | |
|---------------------------------------|
| C2 = 0.33 μ F, 200V, Connection A |
| C2 = 0.22 μ F, 200V, Connection B |

R4 VALUE TABLE

- | |
|----------------------------------|
| R4 = 100 , 1/4W, 25mA Triac Gate |
| R4 = 50 , 1/4W, 50mA Triac Gate |

220VAC

- | | |
|-----------------------------|------------------------------|
| C1 = 0.15 μ F, 400V | R2 = 1.5M , 1/4W |
| C2 = See C2 Value Table | R3 = 27k , 1/4W |
| C3 = 0.047 μ F, 25V | R4 = See R4 Value Table |
| C4 = 470pF, 25V | D1, D2 = IN4148 |
| C5 = 47 μ F, 25V | Z = 15V, 1W (Zener) |
| C6, C7 = 0.001 μ F, 25V | T = Q5004L4 Triac (Typical) |
| (2) R1 = 1k , 2W | L = 200 μ H (RFI Filter) |

(2) For Connection A. Use 1/4 W for Connection B.

C2 VALUE TABLE

- | |
|---------------------------------------|
| C2 = 0.22 μ F, 400V, Connection A |
| C2 = 0.10 μ F, 400V, Connection B |

R4 VALUE TABLE

- | |
|----------------------------------|
| R4 = 100 , 1/4W, 25mA Triac Gate |
| R4 = 50 , 1/4W, 50mA Triac Gate |

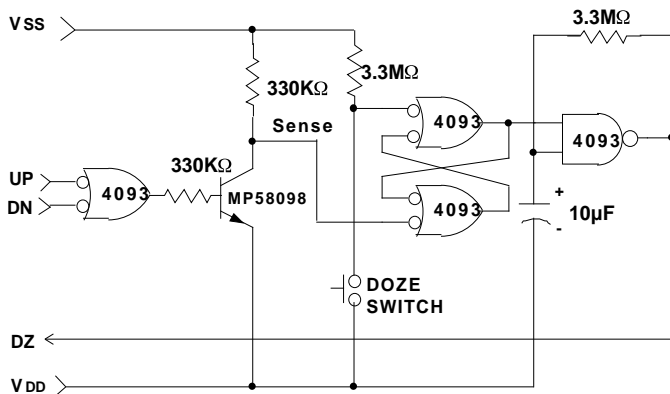

NOTE: All Resistors 1/4W, all Capacitors 25V

FIGURE 6A. DOZE CIRCUIT FOR LS7534

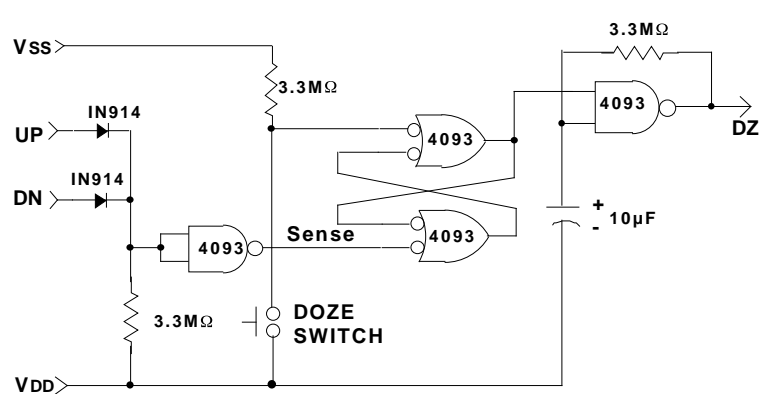

NOTE: All Resistors 1/4 W, all Capacitors 25V.

FIGURE 6B. DOZE CIRCUIT FOR LS7535

DOZE CIRCUIT: (Figures 6A and 6B)

The Doze circuits shown generate a slow clock (0.04Hz) at the DZ terminal. If the UP/DOWN inputs (Figures 5A and 5B) are not activated, the Sense node of the Doze circuit sits at a logic high level. A momentary pressing of the Doze switch sets the SR flip-flop, enabling the oscillator. Every negative transition of the clock (DZ terminal) causes the lamp brightness to be reduced by equal increments, until eventually the lamp is shut-off.

When the lamp is off, the oscillator has no further effect on the dimmer circuit. When the lamp is turned on again by activating the UP input, the SR flip-flop is reset and the DZ clock is turned off.

When the Doze circuit is used, the connection between DOZE input (Pin 2) and Vss (Pin 1), as shown in Figures 5A and 5B, should be removed.

FIGURE 7. OPERATING DESCRIPTION OF A FULL-FEATURE LS7535 WALL SWITCH

See Application Note AN 705 for the Schematic

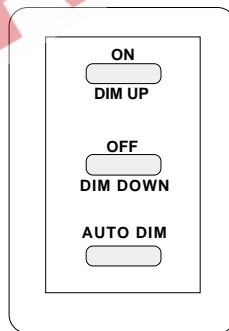

DUAL CONTROL CONTINUOUS DIMMER WITH UNIQUE DELAYED OFF FEATURE

INITIAL CONDITION	ACTION	RESULT
Off	SHORT PRESS On	“Softly” turns On to memory intensity (1)
Off	LONG PRESS On	Varies from min. intensity towards max. intensity (2)
On	LONG PRESS On	Varies towards max. intensity (2)
On	LONG PRESS Off	Varies towards min. intensity (3)
On	SHORT PRESS Off	“Softly” turns Off
On	PRESS Auto-Dim	Begins auto-dimming to off (4)
Auto-Dimming	SHORT PRESS On	“Softly” returns to memory intensity (5)
Auto-Dimming	LONG PRESS On	Varies towards max. intensity (2)
Auto-Dimming	SHORT PRESS Off	“Softly “ turns off
Auto-Dimming	LONG PRESS Off	Varies towards min. intensity (3)
Auto-Dimming	PRESS Auto-Dim	No change
Auto-Dimming	None	Auto-dims to Off

- (1) Last intensity achieved before turn off is stored as memory intensity.
- (2) On (Dim Up) varies intensity towards maximum and stops there.
- (3) Off (Dim Down) varies intensity towards minimum and stops there.
- (4) Auto-dimming period controlled by RC components and intensity level when Auto-Dim is activated.
- (5) Last intensity achieved before Auto-Dim started is stored as memory intensity.