



M2125

LINEAR INTEGRATED CIRCUIT

SINGLE-SUPPLY OPERATIONAL AMPLIFIER

DESCRIPTION

The UTC **M2125** is a single-supply operational amplifier.

FEATURES

- * Single-Supply Operation
- * Low Operating Voltage: $\pm 2.7V \sim 20V$
- * Low Operating Current: 1.0mA (typ.)
- * Slew Rate: 1.2V/ μs (typ.)

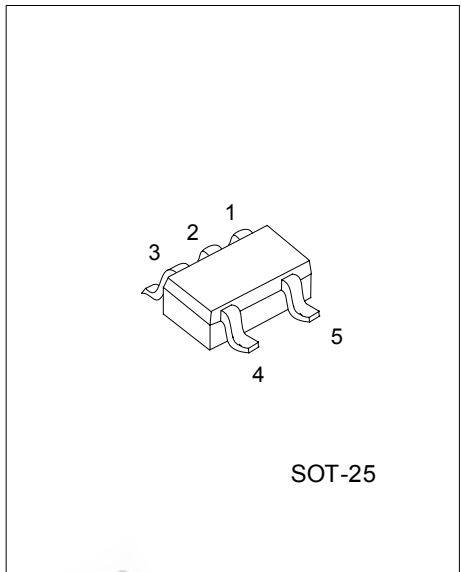

*Pb-free plating product number: M2125L

ORDERING INFORMATION

Order Number		Package	Pin Assignment					Packing
Normal	Lead Free Plating		1	2	3	4	5	
M2125-AF5-0-R	M2125L-AF5-0-R	SOT-25	I ⁺	G	I ⁻	O	V ⁺	Tape Reel

Note: Pin Assignment: I: V_{IN} O: Output G: GND

<p>M2125L-AF5-0-R</p> <p>(1) Packing Type (2) Pin Assignment (3) Package Type (4) Lead Plating</p>	<p>(1) R: Tape Reel (2) refer to Pin Assignment (3) AF5: SOT-25 (4) L: Lead Free Plating, Blank: Pb/Sn</p>
--	--

■ PIN CONFIGURATION

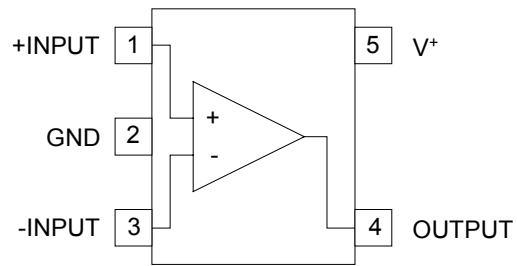

■ EQUIVALENT CIRCUIT

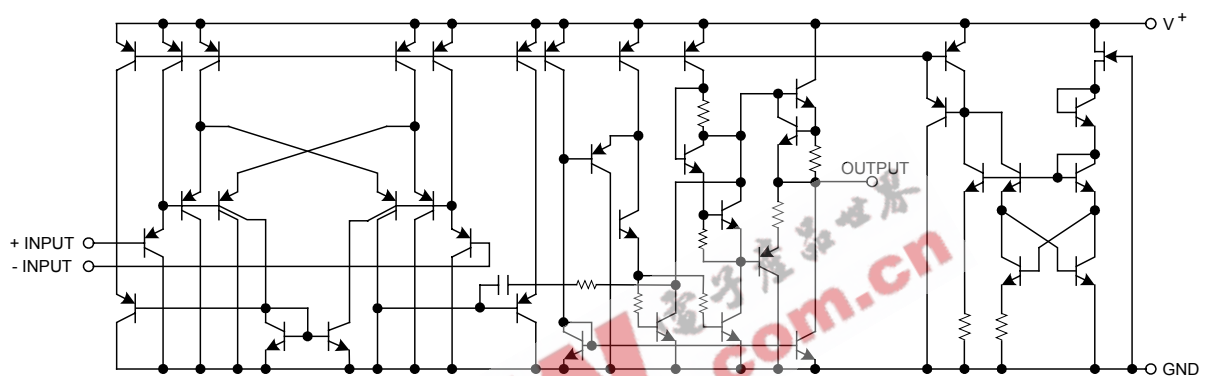

■ ABSOLUTE MAXIMUM RATINGS (Ta=25)

PARAMETER	SYMBOL	RATINGS	UNIT
Supply Voltage	V ⁺	+20	V
Differential Input Voltage	V _{I(DIFF)}	+20	V
Input Voltage	V _{IN}	-0.3 to +20 (note 3)	V
Power Dissipation	P _D	200	mW
Junction Temperature	T _J	+125	°C
Operating Temperature	T _{OPR}	-40~ +85	°C
Storage Temperature	T _{STG}	-40~+150	°C

Note 1. Absolute maximum ratings are those values beyond which the device could be permanently damaged.

Absolute maximum ratings are stress ratings only and functional device operation is not implied.

- The device is guaranteed to meet performance specification within 0 ~+70 operating temperature range and assured by design from -40 ~+85 .
- When the supply voltage is less than +20V, the absolute maximum input voltage is equal to the supply voltage

■ ELECTRICAL CHARACTERISTICS(V⁺=5V,Ta=25)

PARAMETER	SYMBOL	TEST CONDITIONS	MIN	TYP	MAX	UNIT
Input Offset Voltage	V _{I(OFF)}	R _s =0Ω		2	7	mV
Input Offset Current	I _{I(OFF)}			5	50	nA
Input Bias Current	I _{I(BIAS)}			25	250	nA
Large Signal Voltage Gain	G _v	R _L = 2kΩ	88	100		dB
Maximum Output Voltage Swings	V _{OM}	R _L =2kΩ	3.5			V
Input Common Mode Voltage	V _{I(CM)}		0~3.5			V
Common Mode Rejection Ratio	RR		70	90		dB
Supply Voltage Rejection Ratio	SVR		80	94		dB
Output Source Current	I _{SOURCE}	V _{IN} ⁺ =1V, V _{IN} ⁻ =0V	20	30		mA
Output Sink Current	I _{SINK}	V _{IN} ⁺ =0V, V _{IN} ⁻ =1V	8	20		mA
Operating Current	I _{CC}	R _L =∞		1.0	1.75	mA
Slew Rate	SR			1.2		V/μs
Unity Gain Frequency	f _T			1.2		MHz

TYPICAL CHARACTERISTICS

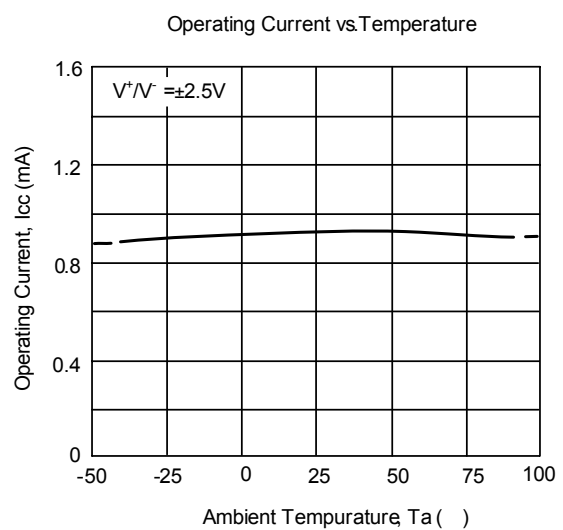
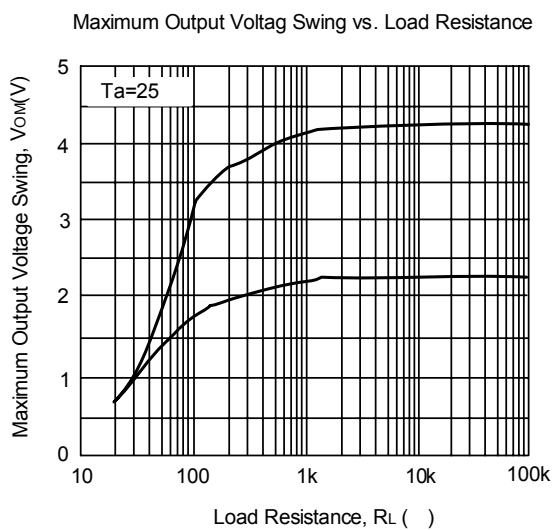
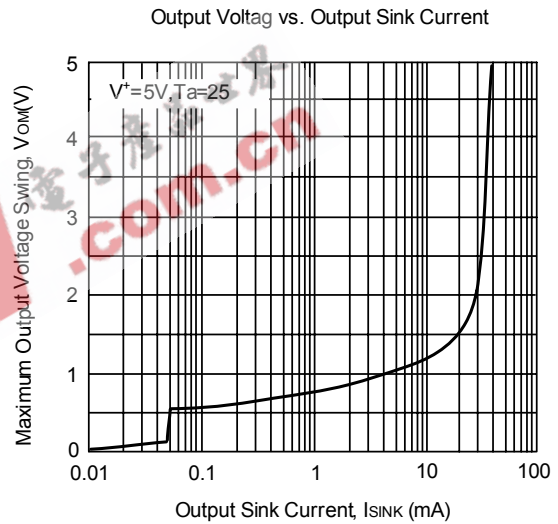
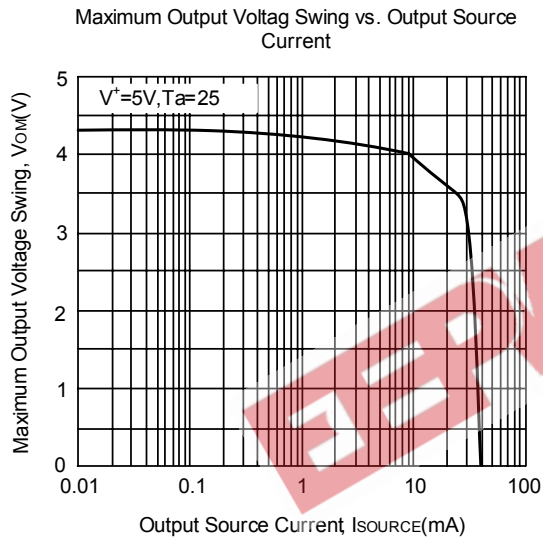
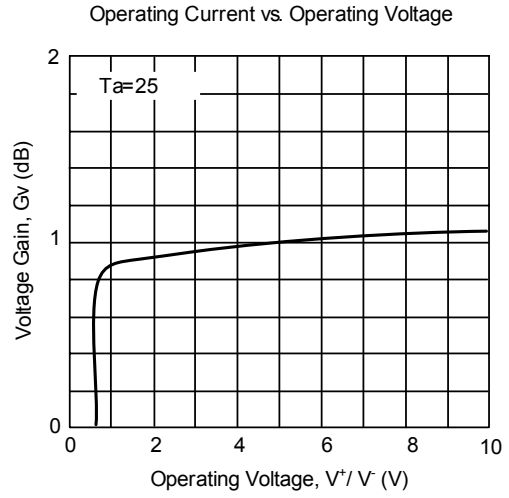
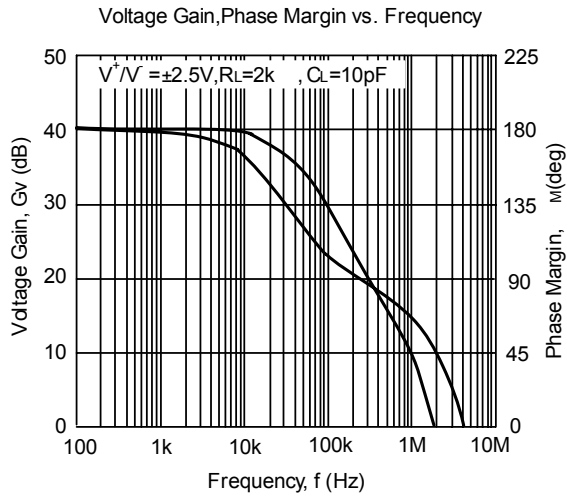

■ TYPICAL CHARSACTERISTICS(Cont.)

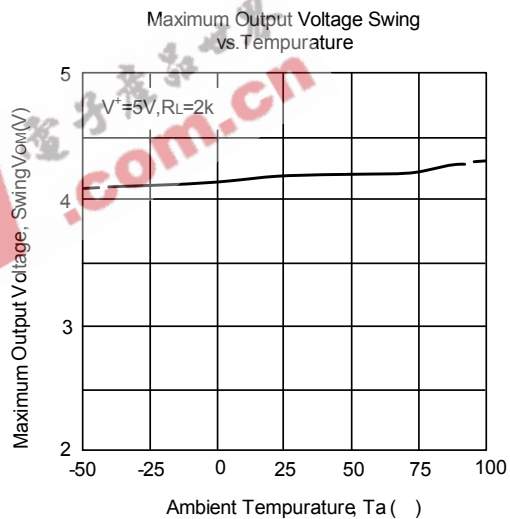
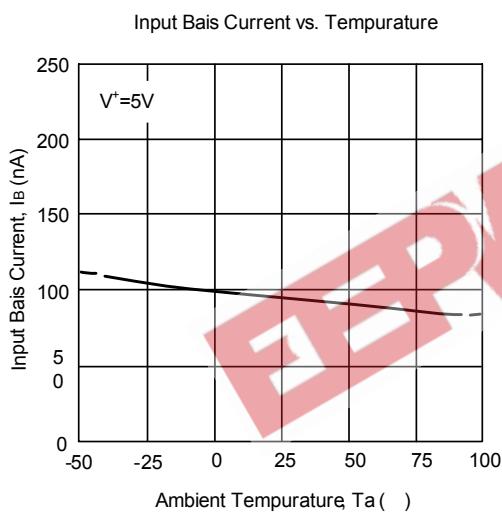
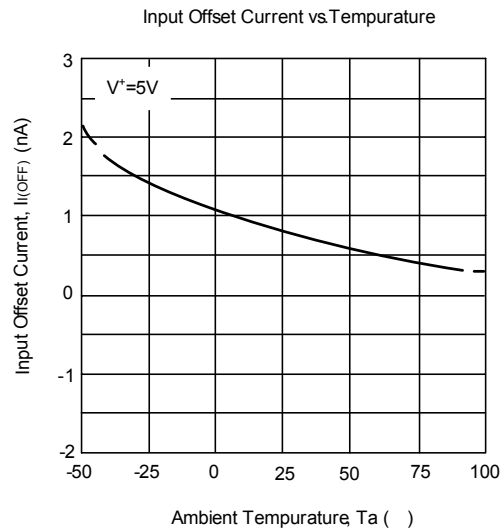
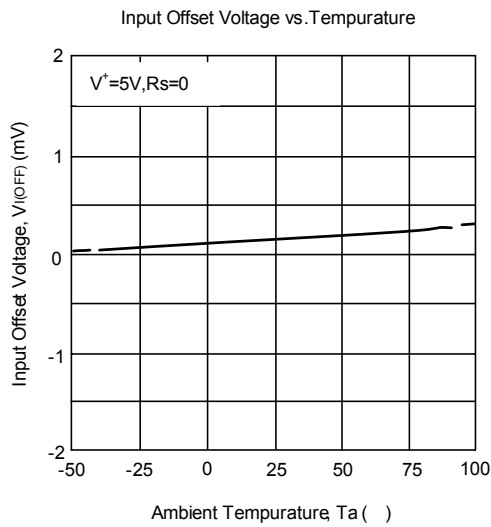

UTC assumes no responsibility for equipment failures that result from using products at values that exceed, even momentarily, rated values (such as maximum ratings, operating condition ranges, or other parameters) listed in products specifications of any and all UTC products described or contained herein. UTC products are not designed for use in life support appliances, devices or systems where malfunction of these products can be reasonably expected to result in personal injury. Reproduction in whole or in part is prohibited without the prior written consent of the copyright owner. The information presented in this document does not form part of any quotation or contract, is believed to be accurate and reliable and may be changed without notice.