

## DECADIC PULSE DIALLER

- R-C OSCILLATOR GENERATES ALL TIMING WITH AN ACCURACY BETTER THAN  $\pm 5\%$  OVER COMPLETE TEMPERATURE RANGE
- DIALLING SPEED CAN BE REGULATED VIA OSCILLATOR FREQUENCY
- TWO MARK/SPACE RATIOS:  $33\frac{1}{3} / 66\frac{2}{3}$  OR 40/60
- AVAILABILITY OF REDIAL WITH TWENTY DIGIT MEMORY WHICH ALSO FUNCTIONS AS BUFFER DURING DIALLING
- CMOS PROCESS
- IGNORES MULTY KEY ENTRIES

The M2560 converts the key press signals into a series of digital pulses similar to those generated by a mechanical dialler.  
The M2560A is available in 18-lead dual in-line plastic package.

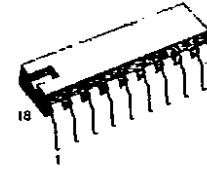

**B**  
DIP-18 Plastic

ORDERING NUMBER: M2560NB1

### PIN CONFIGURATION

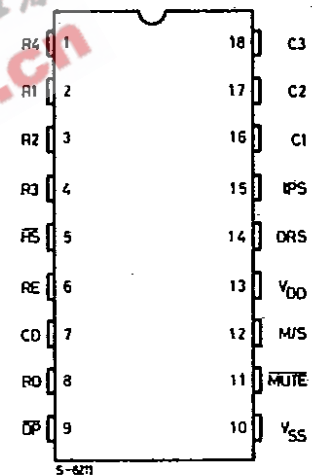

### BLOCK DIAGRAM

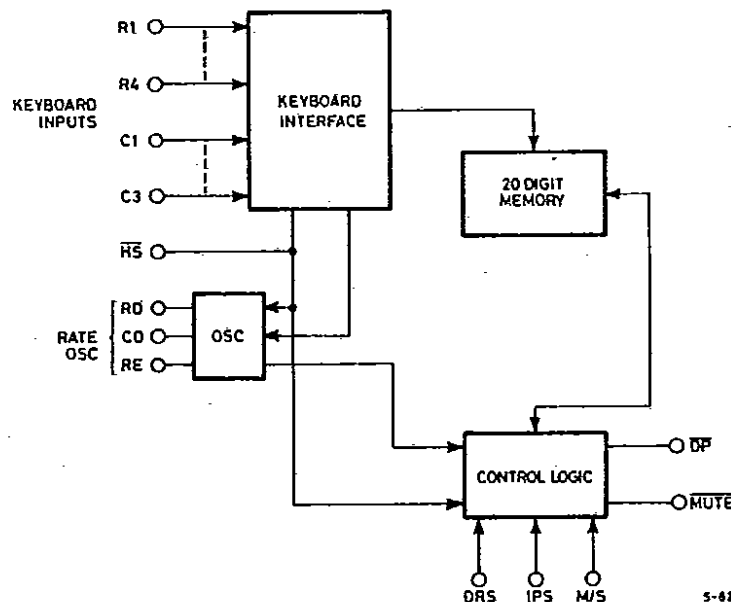

**ELECTRICAL CHARACTERISTICS** (Specifications apply over the operating temperature and  $1.5V \leq V_{DD}$  to  $V_{SS} \leq 3.5V$  unless otherwise specified.

Parameter	$V_{DD}-V_{SS}$ (V)	Test Conditions	Min.	Max.	Units
Output Current Levels					
$I_{OLDP}$	3.5	$V_{OUT} = 0.4V$	125		$\mu A$
$I_{OHDP}$	1.5 3.5	$V_{OUT} = 1V$ $V_{OUT} = 2.5V$	20 125		$\mu A$ $\mu A$
$I_{OLM}$	3.5	$V_{OUT} = 0.4V$	125		$\mu A$
$I_{OHM}$	1.5 3.5	$V_{OUT} = 1V$ $V_{OUT} = 2.5V$	20 125		$\mu A$ $\mu A$
$V_{DR}$		"On Hook" $\overline{HS} = V_{DD}$ Keyboard open, all other input pins to $V_{DD}$ or $V_{SS}$	1.0		V
$I_{DD}$	1.0			750	nA
$I_{DD}$	1.5 3.5	$\overline{DP}, \overline{MUTE}$ open, $\overline{HS} = V_{SS}$ ("Off Hook") Keyboard processing and dial pulsing at 10 pps at conditions as above		100 500	$\mu A$ $\mu A$
$f_o$	1.5			10	kHz
$\Delta f_o/f_o$	1.5 to 2.5 2.5 to 3.5	Fixed R-C oscillator components $50K\Omega \leq R_D \leq 750K\Omega$ ; $100pF \leq CD^* \leq 1000pF$ ; $750k\Omega \leq R_E \leq 5M\Omega$ ; * 300pF most desirable value for CD	-3 -3	+3 +3	% %
Input Voltage Levels					
$V_{IH}$			80% of ( $V_{DD}-V_{SS}$ )	$V_{DD}$ +0.3	V
$V_{IL}$			$V_{SS}$ -0.3	20% of ( $V_{DD}-V_{SS}$ )	V
$C_{IN}$				7.5	pF

**Note:** To prevent excessive dissipation, which could damage the device,  $V_{DD}$  must always be applied before any input is applied. In addition the following conditions must be maintained:  $V_{SS} \leq V_I \leq V_{DD}$ .  
To ensure correct device reset,  $H_S = 1$  should be valid (on Hook condition) when  $V_{DD}$  is applied.

## ABSOLUTE MAXIMUM RATINGS

Symbol	Parameter	Value	Unit
$V_{DD}$	Supply voltage	+ 5.5	V
$V_{IN}$	Voltage at any Pin	$V_{SS} - 0.3V$ to $V_{DD} + 0.3$	V
$T_{stg}$	Storage Temperature Range	-65 to + 150	°C
$T_{op}$	Operating Temperature Range	-25 to + 70	°C
	Lead Temperature (Soldering, 10 sec)	300	°C

Stresses above those listed under "Absolute Maximum Ratings" may cause permanent damage to the device. This is a stress rating only and functional operation of the device at these or any other conditions above those indicated in the operational sections of this specification is not implied. Exposure to absolute maximum rating conditions for extended periods may affect device reliability.

## FUNCTIONAL DESCRIPTION

### OSCILLATOR

An R-C oscillator, with external RC components (2 resistors and a capacitor), supplies all device timing.

This oscillator is operational only while a number is being dialled and dialling pulses are being transmitted. Under all other conditions, including the "On Hook" condition, the oscillator is inoperative.

Typical oscillator frequency, for 10 pps, is 2400Hz, obtained with two external 750K $\Omega$  resistors and a 270pF capacitor. A tolerance of less than  $\pm 1\%$  can be obtained using resistors with 5% tolerance and capacitors with a tolerance of  $\pm 5\%$ .

### KEYBOARD INTERFACE

The M2560 scans the keyboard to establish key state (open or closed)

### OFF HOOK OPERATION

In the Off-Hook condition, the M2560A is supplied via a 150K $\Omega$  resistor. The DP output is normally high, holding the transistor, which replaces the mechanical dial contact, in the on condition. This transistor causes the line disconnects corresponding to the key pressed.

Table 2 shows the various possible operating modes as a function of the programming pins. Obviously modifying the master clock frequency gives a proportional modification of the DIAL RATE and Inter Digit Pause. The chip also includes an anti-bounce delay of 20ms minimum.

### FIRST DIAL AND REDIAL

The digit enter rate is approximately 50ms per digit with a dialling rate in the range 7 to 20 pps. The last dialled number is held in memory for subsequent redialling. Interdigit pause can be inserted during the first dial phase by pressing the "# " key, however the total number of digits pulse pause should not exceed 20.

Redial is obtained by lifting the handset and pressing the "# " key which causes the number to be automatically sent to the line. If a pause is detected the line pulsing is suspended until the "# " key is pressed.

### PIN DESCRIPTION

**Keyboard Keys** (R1, R2, R3, R4, C1, C2, C3)  
Pins 1, 2, 3, 4, 16, 17, 18

The key contact resistance must be less than or equal to 1K $\Omega$ .

**Hook Switch ( $\overline{HS}$ )** - Pin 5

Detects the On-Hook/Off-Hook condition with a low level corresponding to the Off-Hook condition.

**Oscillator (RE, CD, RD)** - Pins 6, 7, 8

Connections to the external components for the RC oscillator.

**Pulse Output ( $\overline{DP}$ )** - Pin 9

Supplies the dial pulses to the line disconnect transistor.

**FUNCTIONAL DESCRIPTION (Continued)**

**Mute Output ( $\overline{\text{MUTE}}$ ) - Pin 11**

Drives the external receiver muting transistor.

**Mark Space Selection (MS) - Pin 12**

See relative table.

**Dial Rate Selection (DRS) - Pin 14**

See relative table

**Inter Digit Pause Selection (IPS) - Pin 15)**

See relative table. (Note an interdigit pause is also sent before the first digit pulses are sent to the line)

**V<sub>DD</sub> - Pin 13**

**V<sub>SS</sub> - Pin 10**

**Table 2. Table for Selecting Oscillator Component Values for Desired Dialing Rates and Inter-Digit Pauses**

Dial Rate Desired	Osc. Freq. (Hz)	RD (kΩ)	RE (kΩ)	CD (pF)	Dial Rate (pps)		IDP (ms)	
					*DRS=V <sub>SS</sub>	DRS=V <sub>DD</sub>	IPS=V <sub>SS</sub>	IPS=V <sub>DD</sub>
5.5/11	1320	Select components in the ranges indicated in table of electrical specifications			5.5	11	1454	727
6/12	1440				6	12	1334	667
6.5/13	1560				6.5	13	1230	615
7/14	1680				7	14	1142	571
7.5/15	1800				7.5	15	1066	533
8/16	1920				8	16	1000	500
8.5/17	2040				8.5	17	942	471
9/18	2160				9	18	888	444
9.5/19	2280				9.5	19	842	421
10/20	2400				750	750	270	10
(f <sub>d</sub> /240) (f <sub>d</sub> /120)	f <sub>d</sub>				(f <sub>d</sub> /240)	(f <sub>d</sub> /120)	$\left(\frac{1920}{f_i} \times 10^3\right)$	$\left(\frac{960}{f_i} \times 10^3\right)$

Note: IDP is dependent on the dialing rate selected. For example, for a dialing rate of 10 pps, an IDP of either 800ms or 400ms can be selected. For a dialing rate of 14 pps, and IDP of either 1142ms or 571ms can be selected.

\* DRS status scales of a factor 2.

**Table 3.**

Function	Pin Designation	Input Logic Level	Selection
Dial Pulse Rate Selection	DRS	V <sub>SS</sub> V <sub>DD</sub>	(f/240) pps (f/120) pps
Inter-Digit Pause Selection	IPS	V <sub>DD</sub> V <sub>SS</sub>	$\frac{960}{f}$ s $\frac{1920}{f}$ s
Mark/Space Ratio	M/S	V <sub>SS</sub> V <sub>DD</sub>	33-1/3/66-2/3 40/60
On Hook/Off Hook	$\overline{\text{HS}}$	V <sub>DD</sub> V <sub>SS</sub>	On Hook Off Hook

Note: f is the oscillator frequency.

Timing

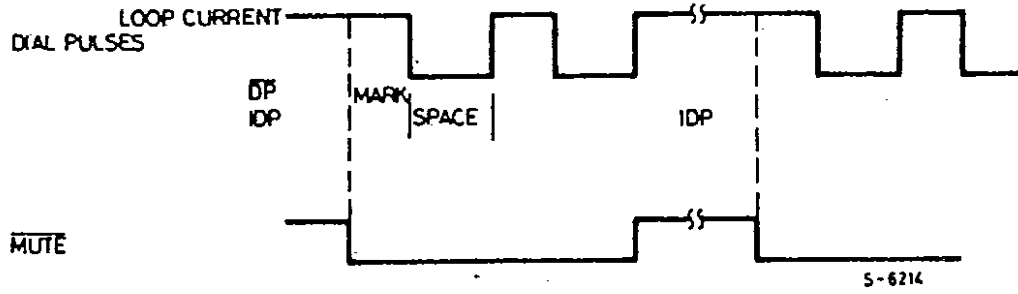

Switch Matrix Interface

