

2.0A

PIN CONFIGURATION

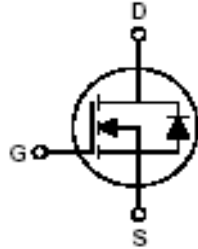
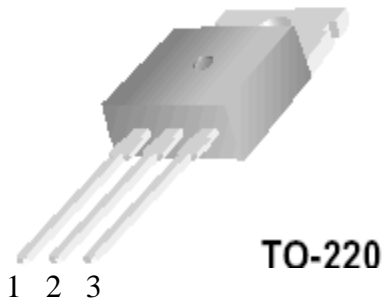

1.Gate 2.Drain 3.Source

FEATURE

- Robust High Voltage Termination.
- Avalanche Energy Specified
- Source-to Drain Diode Recovery Time Comparable to a Discrete Fast Recovery Diode
- Diode is Characterized for Use in Bridge Circuits
- I_{DSS} and $V_{DS(on)}$ Specified at Elevated Temperature

ABSOLUTE MAXIMUM RATINGS

RATING	SYMBOL	VALUE	UNIT
Drain to Current - Continuous - Pulsed	I_D I_{DM}	2.0 9.0	A
Gate-to-Source Voltage – Continue - Non-repetitive	V_{GS} V_{GSM}	+/-20 +/-40	V V
Total Power Dissipation TO-251/252 TO-220	P_D	60 60	W
Operating and Storage Temperature Range	T_J, T_{STG}	-55 to 150	
Single Pulse Drain-to-Source Avalanche Energy – $T_j = 25$ ($V_{DD} = 100V, V_{GS} = 10V, I_{AS} = 2A, L = 10mH, R_G = 25$)	E_{AS}	20	mJ
Thermal Resistance – Junction to Case - Junction to Ambient	θ_{JC} θ_{JA}	1.0 62.5	/W
Maximum Lead Temperature for Soldering Purposes, 1/8” form 10 seconds	T_L	260	



STANSON TECHNOLOGY

120 Bentley Square, Mountain View, Ca 94040 USA
 TEL: (650) 9389294 FAX: (650) 9389295

2.0A

MAXIMUM RATINGS AND ELECTRICAL CHARACTERISTICS ($T_a=25$)

PARAMETERS	SYMBOL	MIN	TYP	MAX	UNIT	CONDITION
Drain-Source Breakdown Voltage	$V_{(BR)DSS}$	600			Vdc	$V_{GS}=0, I_D=250\mu A$
Drain-Source Leakage Current	I_{DSS}			0.1 1.0	mA mA	$V_{DS}=600V, V_{GS}=0$ $V_{DS}=480V, V_{GS}=0, T_j=125$
Gate-Source Leakage Current-Forward	I_{GSSF}			100	nA	$V_{GSF}=20V, V_{DS}=0$
Gate Threshold Voltage	$V_{GS(th)}$	2.0		4.0	V	$V_{DS}=V_{GS}, I_D=250\mu A$
Drain-Source On-Resistance	$R_{DS(on)}$			4.4	Ohm	$V_{GS}=10V, I_D=1.2A^*$
Input Capacitance	C_{iss}		435		pF	$V_{DS}=25V, V_{GS}=0, f=1\text{ MHz}$
Output Capacitance	C_{oss}		56		pF	
Reverse Transfer Capacitance	C_{rss}		9.2		pF	
Turn-On Delay Time	$t_{d(on)}$		12		nS	$V_{DD}=300V, I_D=2.0A,$ $V_{GS}=10V, R_G=18$
Turn-Off Delay Time	$T_{d(off)}$		30		nS	
Rise Time	t_r		21		nS	
Fall Time	t_f		24		nS	
Total Gate Charge	Q_g		13	22	nC	$V_{DS}=400V, I_D=2.0A$ $V_{GS}=10V^*$
Gate-Drain Charge	Q_{gd}		6.0		nC	
Gate-Drain Charge	Q_{gs}		2.0		nC	
Internal Drain Inductance	L_D		4.5		nH	Measured from the drain lead 0.25'' From package to center of die
Internal Drain Inductance	L_s		7.5		nH	Measured from the source lead 0.25'' from package to source bond pad
SOURCE-DRAIN DIODE CHARACTERISTICS						
Forward On-Voltage(1)	VDS			1.5	V	$I_s=2.0A, V_{GS}=0V$ $d_{IS}/d_t = 100A/\mu S$
Forward Turn Time	t_{on}		**		nS	
Reverse Recovery Time	t_{rr}		340		nS	

*Pulse Test: Pulse Width 300 μS , Duty Cycle 2%

**Negligible, Dominated by circuit inductance

**STANSON TECHNOLOGY**

120 Bentley Square, Mountain View, Ca 94040 USA

TEL: (650) 9389294 FAX: (650) 9389295

TYPICAL CHARACTERISTICS

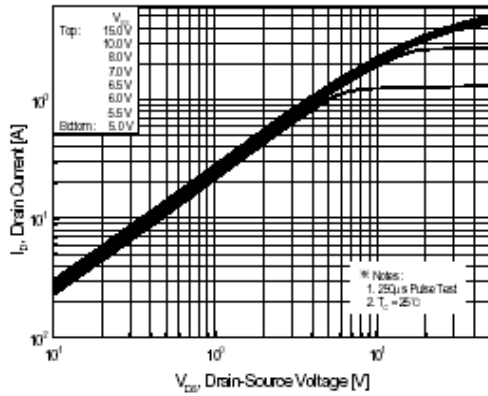

Figure 1. On-Region Characteristics

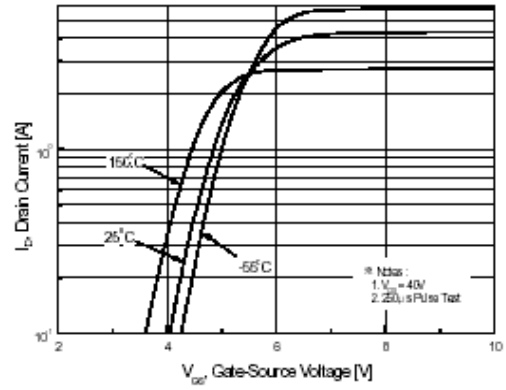

Figure 2. Transfer Characteristics

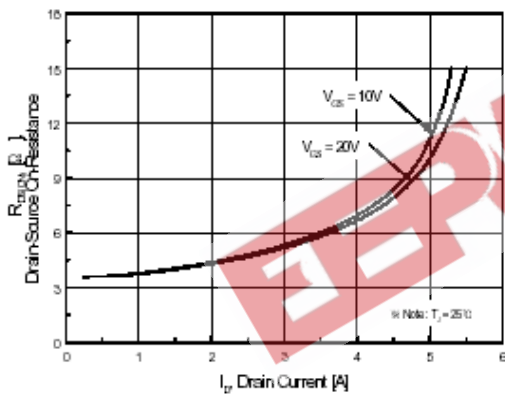

Figure 3. On-Resistance Variation vs Drain Current and Gate Voltage

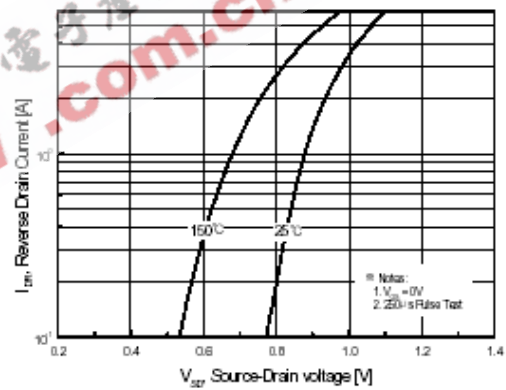

Figure 4. Body Diode Forward Voltage Variation with Source Current and Temperature

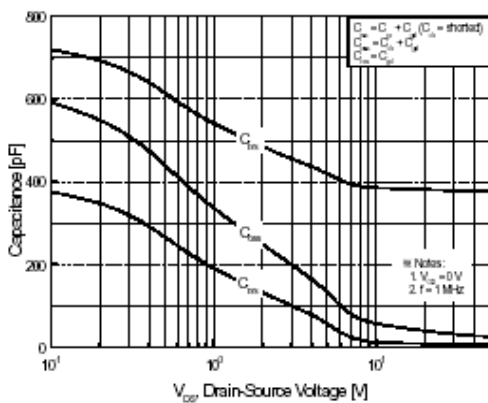

Figure 5. Capacitance Characteristics

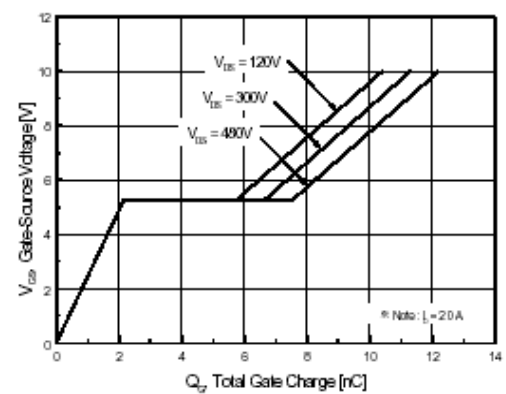

Figure 6. Gate Charge Characteristics

TYPICAL CHARACTERISTICS (CONTINUED)

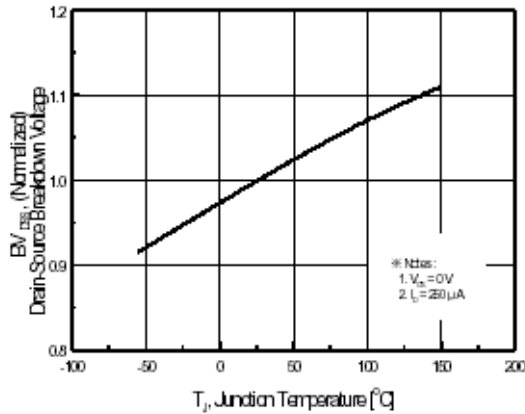

Figure 7. Breakdown Voltage Variation vs Temperature

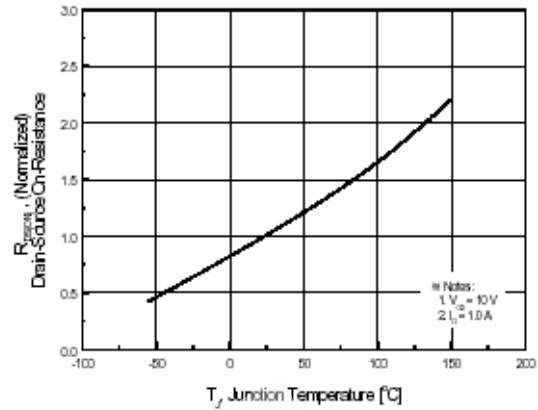

Figure 8. On-Resistance Variation vs Temperature

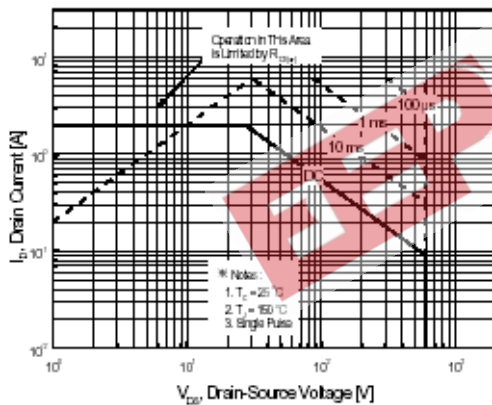

Figure 9-1. Maximum Safe Operating Area

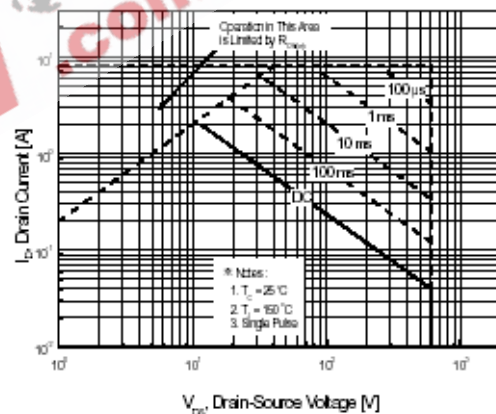

Figure 9-2. Maximum Safe Operating Area

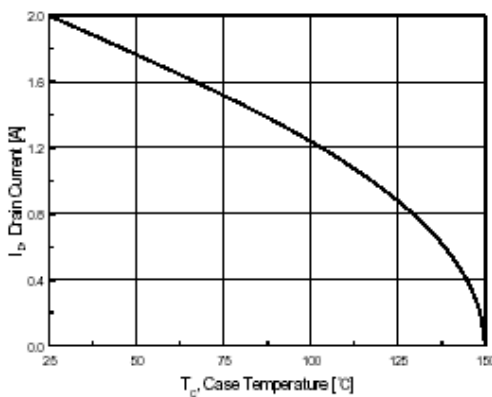
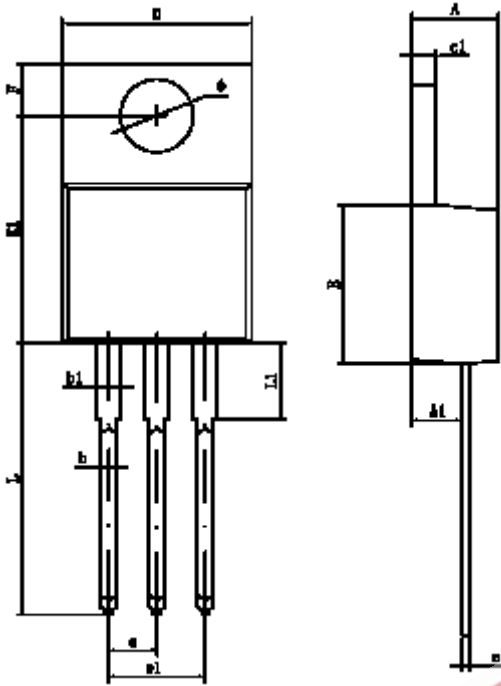

Figure 10. Maximum Drain Current vs Case Temperature

2.0A

TO-220-3L PACKAGE OUTLINE DIMENSIONS



SAMBOL	DIMENSIONS IN MILLIMETERS	
	MIN	MAX
A	4.470	4.670
A1	2.520	2.820
B	0.710	0.910
b	1.170	0.910
b1	1.170	1.370
c	0.310	0.530
c1	1.170	1.370
D	10.01	10.31
E	8.500	8.900
E1	12.06	12.46
e	2.540 TYP	
e1	4.980	5.180
F	2.590	2.890
L	13.40	13.80
L1	3.560	3.960
	3.790	3.890



STANSON TECHNOLOGY

120 Bentley Square, Mountain View, Ca 94040 USA