



## M27C160

### 16 Mbit (2Mb x 8 or 1Mb x 16) UV EPROM and OTP EPROM

- 5V  $\pm$  10% SUPPLY VOLTAGE in READ OPERATION
- ACCESS TIME: 50ns
- BYTE-WIDE or WORD-WIDE CONFIGURABLE
- 16 Mbit MASK ROM REPLACEMENT
- LOW POWER CONSUMPTION
  - Active Current 70mA at 8MHz
  - Standby Current 100 $\mu$ A
- PROGRAMMING VOLTAGE: 12.5V  $\pm$  0.25V
- PROGRAMMING TIME: 50 $\mu$ s/word
- ELECTRONIC SIGNATURE
  - Manufacturer Code: 20h
  - Device Code: B1h

#### DESCRIPTION

The M27C160 is a 16 Mbit EPROM offered in the two ranges UV (ultra violet erase) and OTP (one time programmable). It is ideally suited for micro-processor systems requiring large data or program storage and is organised as either 2 Mbit words of 8 bit or 1 Mbit words of 16 bit. The pin-out is compatible with a 16 Mbit Mask ROM.

The FDIP42W (window ceramic frit-seal package) has a transparent lid which allows the user to expose the chip to ultraviolet light to erase the bit pattern. A new pattern can then be written rapidly to the device by following the programming procedure.

For applications where the content is programmed only one time and erasure is not required, the M27C160 is offered in PDIP42, SDIP42, PLCC44 and SO44 packages.

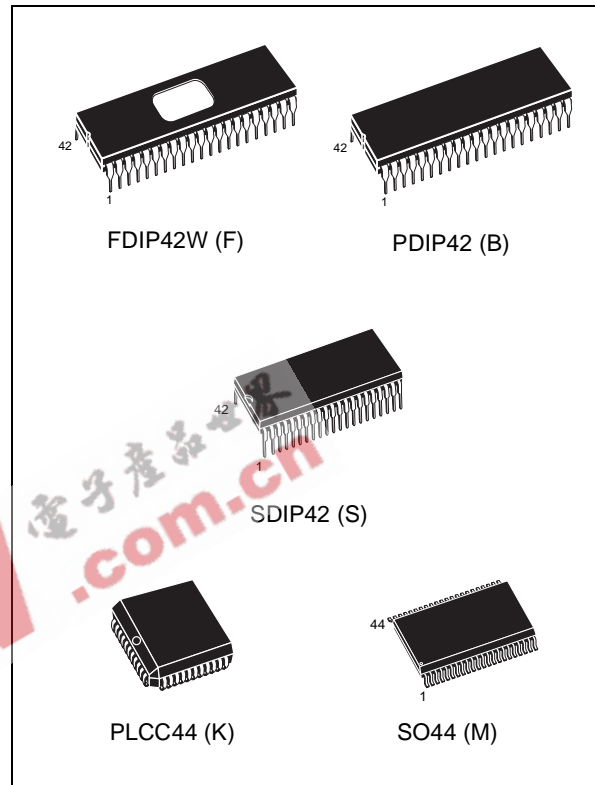
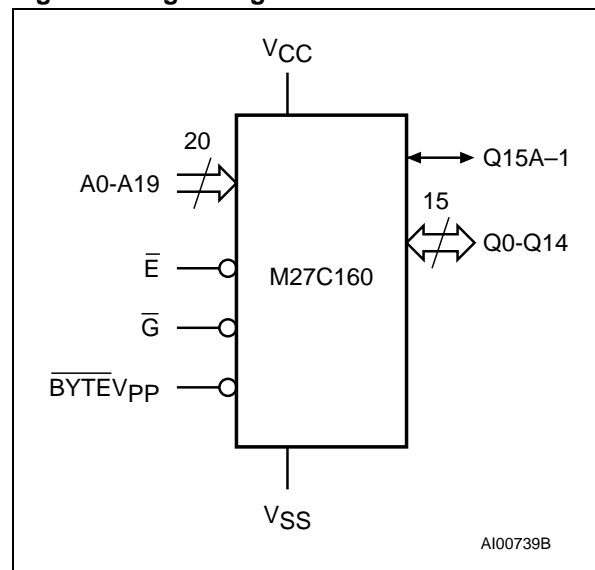
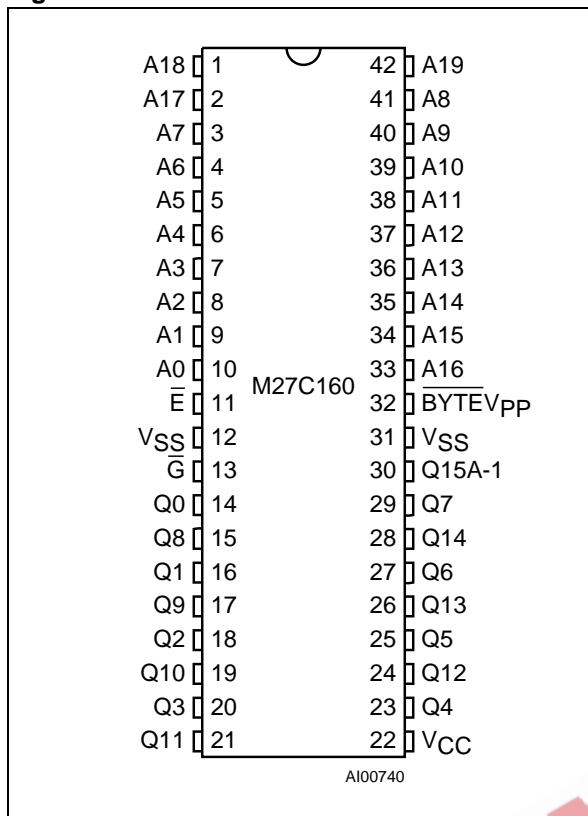

Figure 1. Logic Diagram



# M27C160

**Figure 2. DIP Connections**



**Figure 3. PLCC Connections**

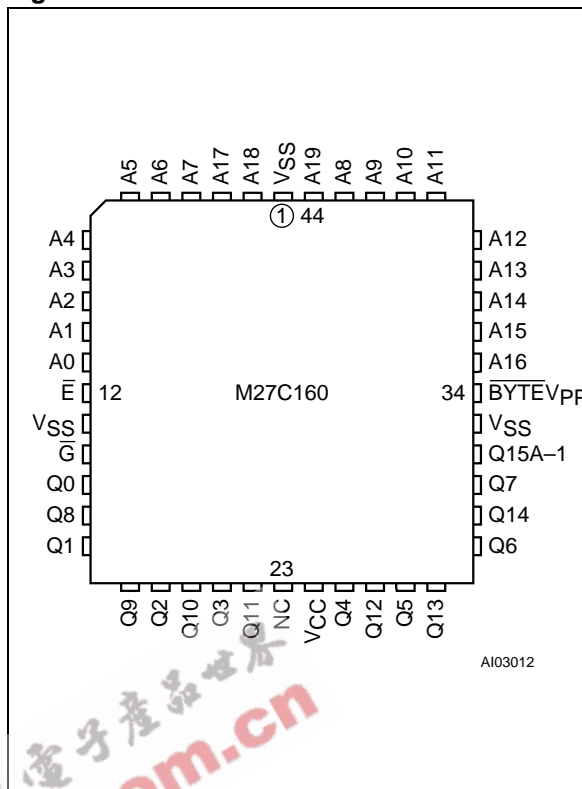

**Figure 4. SO Connections**

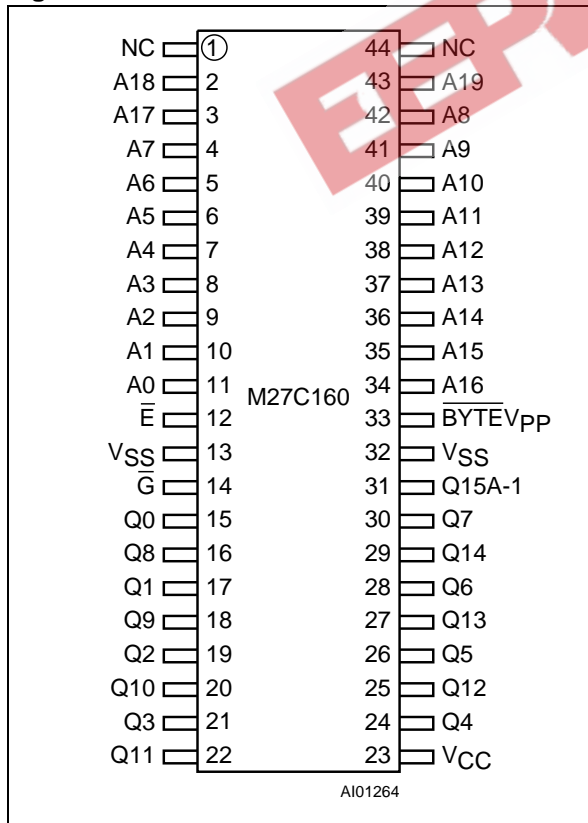

**Table 1. Signal Names**

A0-A19	Address Inputs
Q0-Q7	Data Outputs
Q8-Q14	Data Outputs
Q15A-1	Data Output / Address Input
$\bar{E}$	Chip Enable
$\bar{G}$	Output Enable
$\overline{BYTEVPP}$	Byte Mode / Program Supply
VCC	Supply Voltage
VSS	Ground
NC	Not Connected Internally

**Table 2. Absolute Maximum Ratings (1)**

Symbol	Parameter	Value	Unit
T <sub>A</sub>	Ambient Operating Temperature (3)	-40 to 125	°C
T <sub>BIAS</sub>	Temperature Under Bias	-50 to 125	°C
T <sub>STG</sub>	Storage Temperature	-65 to 150	°C
V <sub>IO</sub> (2)	Input or Output Voltage (except A9)	-2 to 7	V
V <sub>CC</sub>	Supply Voltage	-2 to 7	V
V <sub>A9</sub> (2)	A9 Voltage	-2 to 13.5	V
V <sub>PP</sub>	Program Supply Voltage	-2 to 14	V

Note: 1. Except for the rating "Operating Temperature Range", stresses above those listed in the Table "Absolute Maximum Ratings" may cause permanent damage to the device. These are stress ratings only and operation of the device at these or any other conditions above those indicated in the Operating sections of this specification is not implied. Exposure to Absolute Maximum Rating conditions for extended periods may affect device reliability. Refer also to the STMicroelectronics SURE Program and other relevant quality documents.

2. Minimum DC voltage on Input or Output is -0.5V with possible undershoot to -2.0V for a period less than 20ns. Maximum DC voltage on Output is V<sub>CC</sub> +0.5V with possible overshoot to V<sub>CC</sub> +2V for a period less than 20ns.
3. Depends on range.

**Table 3. Operating Modes**

Mode	$\bar{E}$	$\bar{G}$	$\overline{BYTEV_{PP}}$	A9	Q15A-1	Q8-Q14	Q7-Q0
Read Word-wide	V <sub>IL</sub>	V <sub>IL</sub>	V <sub>IH</sub>	X	Data Out	Data Out	Data Out
Read Byte-wide Upper	V <sub>IL</sub>	V <sub>IL</sub>	V <sub>IL</sub>	X	V <sub>IH</sub>	Hi-Z	Data Out
Read Byte-wide Lower	V <sub>IL</sub>	V <sub>IL</sub>	V <sub>IL</sub>	X	V <sub>IL</sub>	Hi-Z	Data Out
Output Disable	V <sub>IL</sub>	V <sub>IH</sub>	X	X	Hi-Z	Hi-Z	Hi-Z
Program	V <sub>IL</sub> Pulse	V <sub>IH</sub>	V <sub>PP</sub>	X	Data In	Data In	Data In
Verify	V <sub>IH</sub>	V <sub>IL</sub>	V <sub>PP</sub>	X	Data Out	Data Out	Data Out
Program Inhibit	V <sub>IH</sub>	V <sub>IH</sub>	V <sub>PP</sub>	X	Hi-Z	Hi-Z	Hi-Z
Standby	V <sub>IH</sub>	X	X	X	Hi-Z	Hi-Z	Hi-Z
Electronic Signature	V <sub>IL</sub>	V <sub>IL</sub>	V <sub>IH</sub>	V <sub>ID</sub>	Code	Codes	Codes

Note: X = V<sub>IH</sub> or V<sub>IL</sub>, V<sub>ID</sub> = 12V ± 0.5V.

**Table 4. Electronic Signature**

Identifier	A0	Q7	Q6	Q5	Q4	Q3	Q2	Q1	Q0	Hex Data
Manufacturer's Code	V <sub>IL</sub>	0	0	1	0	0	0	0	0	20h
Device Code	V <sub>IH</sub>	1	0	1	1	0	0	0	1	B1h

Note: Outputs Q15-Q8 are set to '0'.

Table 5. AC Measurement Conditions

	High Speed	Standard
Input Rise and Fall Times	≤ 10ns	≤ 20ns
Input Pulse Voltages	0 to 3V	0.4V to 2.4V
Input and Output Timing Ref. Voltages	1.5V	0.8V and 2V

Figure 5. AC Testing Input Output Waveform

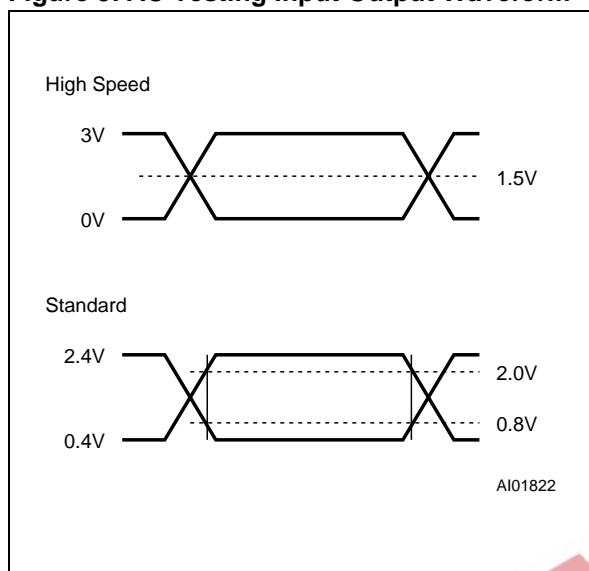

Figure 6. AC Testing Load Circuit

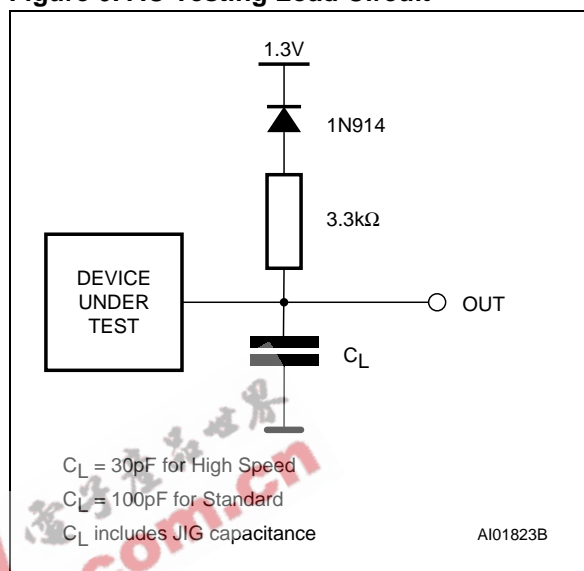

Table 6. Capacitance <sup>(1)</sup> (T<sub>A</sub> = 25 °C, f = 1 MHz)

Symbol	Parameter	Test Condition	Min	Max	Unit
C <sub>IN</sub>	Input Capacitance (except $\overline{\text{BYTEV}}_{\text{PP}}$ )	V <sub>IN</sub> = 0V		10	pF
	Input Capacitance ( $\overline{\text{BYTEV}}_{\text{PP}}$ )	V <sub>IN</sub> = 0V		120	pF
C <sub>OUT</sub>	Output Capacitance	V <sub>OUT</sub> = 0V		12	pF

Note: 1. Sampled only, not 100% tested.

**DEVICE OPERATION**

The operating modes of the M27C160 are listed in the Operating Modes Table. A single power supply is required in the read mode. All inputs are TTL compatible except for V<sub>PP</sub> and 12V on A9 for the Electronic Signature.

**Read Mode**

The M27C160 has two organisations, Word-wide and Byte-wide. The organisation is selected by the signal level on the  $\overline{\text{BYTEV}}_{\text{PP}}$  pin. When  $\overline{\text{BYTEV}}_{\text{PP}}$  is at V<sub>IH</sub> the Word-wide organisation is selected and the Q15A-1 pin is used for Q15 Data Output. When the  $\overline{\text{BYTEV}}_{\text{PP}}$  pin is at V<sub>IL</sub> the Byte-wide organisation is selected and the Q15A-1 pin is used for the Address Input A-1. When the memory is logically regarded as 16 bit wide, but read in the Byte-wide organisation, then with A-1 at V<sub>IL</sub> the

lower 8 bits of the 16 bit data are selected and with A-1 at V<sub>IH</sub> the upper 8 bits of the 16 bit data are selected.

The M27C160 has two control functions, both of which must be logically active in order to obtain data at the outputs. In addition the Word-wide or Byte-wide organisation must be selected.

Chip Enable ( $\overline{\text{E}}$ ) is the power control and should be used for device selection. Output Enable ( $\overline{\text{G}}$ ) is the output control and should be used to gate data to the output pins independent of device selection. Assuming that the addresses are stable, the address access time (t<sub>AVQV</sub>) is equal to the delay from  $\overline{\text{E}}$  to output (t<sub>ELQV</sub>). Data is available at the output after a delay of t<sub>GLQV</sub> from the falling edge of  $\overline{\text{G}}$ , assuming that  $\overline{\text{E}}$  has been low and the addresses have been stable for at least t<sub>AVQV</sub>-t<sub>GLQV</sub>.

**Table 7. Read Mode DC Characteristics <sup>(1)</sup>**(T<sub>A</sub> = 0 to 70 °C or -40 to 85 °C; V<sub>CC</sub> = 5V ± 5% or 5V ± 10%; V<sub>PP</sub> = V<sub>CC</sub>)

Symbol	Parameter	Test Condition	Min	Max	Unit
I <sub>LI</sub>	Input Leakage Current	0V ≤ V <sub>IN</sub> ≤ V <sub>CC</sub>		±1	μA
I <sub>LO</sub>	Output Leakage Current	0V ≤ V <sub>OUT</sub> ≤ V <sub>CC</sub>		±10	μA
I <sub>CC</sub>	Supply Current	$\bar{E} = V_{IL}, \bar{G} = V_{IL}, I_{OUT} = 0mA, f = 8MHz$		70	mA
		$\bar{E} = V_{IL}, \bar{G} = V_{IL}, I_{OUT} = 0mA, f = 5MHz$		50	mA
I <sub>CC1</sub>	Supply Current (Standby) TTL	$\bar{E} = V_{IH}$		1	mA
I <sub>CC2</sub>	Supply Current (Standby) CMOS	$\bar{E} > V_{CC} - 0.2V$		100	μA
I <sub>PP</sub>	Program Current	V <sub>PP</sub> = V <sub>CC</sub>		10	μA
V <sub>IL</sub>	Input Low Voltage		-0.3	0.8	V
V <sub>IH</sub> <sup>(2)</sup>	Input High Voltage		2	V <sub>CC</sub> + 1	V
V <sub>OL</sub>	Output Low Voltage	I <sub>OL</sub> = 2.1mA		0.4	V
V <sub>OH</sub>	Output High Voltage TTL	I <sub>OH</sub> = -400μA	2.4		V

Note: 1. V<sub>CC</sub> must be applied simultaneously with or before V<sub>PP</sub> and removed simultaneously or after V<sub>PP</sub>.  
 2. Maximum DC voltage on Output is V<sub>CC</sub> + 0.5V.

### Standby Mode

The M27C160 has a standby mode which reduces the active current from 50mA to 100μA. The M27C160 is placed in the standby mode by applying a CMOS high signal to the  $\bar{E}$  input. When in the standby mode, the outputs are in a high impedance state, independent of the  $\bar{G}$  input.

### Two Line Output Control

Because EPROMs are usually used in larger memory arrays, this product features a 2 line control function which accommodates the use of multiple memory connection. The two line control function allows:

- the lowest possible memory power dissipation,
- complete assurance that output bus contention will not occur.

For the most efficient use of these two control lines,  $\bar{E}$  should be decoded and used as the primary device selecting function, while  $\bar{G}$  should be made a common connection to all devices in the array and connected to the READ line from the system control bus. This ensures that all deselected memory devices are in their low power standby mode and that the output pins are only active when data is required from a particular memory device.

### System Considerations

The power switching characteristics of Advanced CMOS EPROMs require careful decoupling of the supplies to the devices. The supply current I<sub>CC</sub> has three segments of importance to the system designer: the standby current, the active current and the transient peaks that are produced by the falling and rising edges of  $\bar{E}$ .

The magnitude of the transient current peaks is dependent on the capacitive and inductive loading of the device outputs. The associated transient voltage peaks can be suppressed by complying with the two line output control and by properly selected decoupling capacitors. It is recommended that a 0.1μF ceramic capacitor is used on every device between V<sub>CC</sub> and V<sub>SS</sub>. This should be a high frequency type of low inherent inductance and should be placed as close as possible to the device. In addition, a 4.7μF electrolytic capacitor should be used between V<sub>CC</sub> and V<sub>SS</sub> for every eight devices.

This capacitor should be mounted near the power supply connection point. The purpose of this capacitor is to overcome the voltage drop caused by the inductive effects of PCB traces.

## M27C160

**Table 8. Read Mode AC Characteristics (1)**

( $T_A = 0$  to  $70$  °C or  $-40$  to  $85$  °C;  $V_{CC} = 5V \pm 5\%$  or  $5V \pm 10\%$ ;  $V_{PP} = V_{CC}$ )

Symbol	Alt	Parameter	Test Condition	M27C160				Unit
				-50 <sup>(3)</sup>		-70 <sup>(3)</sup>		
				Min	Max	Min	Max	
$t_{AVQV}$	$t_{ACC}$	Address Valid to Output Valid	$\bar{E} = V_{IL}, \bar{G} = V_{IL}$		50		70	ns
$t_{BHQV}$	$t_{ST}$	BYTE High to Output Valid	$\bar{E} = V_{IL}, \bar{G} = V_{IL}$		50		70	ns
$t_{ELQV}$	$t_{CE}$	Chip Enable Low to Output Valid	$\bar{G} = V_{IL}$		50		70	ns
$t_{GLQV}$	$t_{OE}$	Output Enable Low to Output Valid	$\bar{E} = V_{IL}$		30		35	ns
$t_{BLQZ}^{(2)}$	$t_{STD}$	BYTE Low to Output Hi-Z	$\bar{E} = V_{IL}, \bar{G} = V_{IL}$		30		30	ns
$t_{EHQZ}^{(2)}$	$t_{DF}$	Chip Enable High to Output Hi-Z	$\bar{G} = V_{IL}$	0	25	0	25	ns
$t_{GHQZ}^{(2)}$	$t_{DF}$	Output Enable High to Output Hi-Z	$\bar{E} = V_{IL}$	0	25	0	25	ns
$t_{AXQX}$	$t_{OH}$	Address Transition to Output Transition	$\bar{E} = V_{IL}, \bar{G} = V_{IL}$	5		5		ns
$t_{BLQX}$	$t_{OH}$	BYTE Low to Output Transition	$\bar{E} = V_{IL}, \bar{G} = V_{IL}$	5		5		ns

Note: 1.  $V_{CC}$  must be applied simultaneously with or before  $V_{PP}$  and removed simultaneously or after  $V_{PP}$ .  
 2. Sampled only, not 100% tested.  
 3. Speed obtained with High Speed AC measurement conditions.

**Table 9. Read Mode AC Characteristics <sup>(1)</sup>**(T<sub>A</sub> = 0 to 70 °C or -40 to 85 °C; V<sub>CC</sub> = 5V ± 5% or 5V ± 10%; V<sub>PP</sub> = V<sub>CC</sub>)

Symbol	Alt	Parameter	Test Condition	M27C160						Unit
				-90		-100		-120/-150		
				Min	Max	Min	Max	Min	Max	
t <sub>AVQV</sub>	t <sub>ACC</sub>	Address Valid to Output Valid	$\bar{E} = V_{IL}, \bar{G} = V_{IL}$		90		100		120	ns
t <sub>BHQV</sub>	t <sub>ST</sub>	BYTE High to Output Valid	$\bar{E} = V_{IL}, \bar{G} = V_{IL}$		90		100		120	ns
t <sub>ELQV</sub>	t <sub>CE</sub>	Chip Enable Low to Output Valid	$\bar{G} = V_{IL}$		90		100		120	ns
t <sub>GLQV</sub>	t <sub>OE</sub>	Output Enable Low to Output Valid	$\bar{E} = V_{IL}$		45		50		60	ns
t <sub>BLQZ</sub> <sup>(2)</sup>	t <sub>STD</sub>	BYTE Low to Output Hi-Z	$\bar{E} = V_{IL}, \bar{G} = V_{IL}$		30		40		50	ns
t <sub>EHQZ</sub> <sup>(2)</sup>	t <sub>DF</sub>	Chip Enable High to Output Hi-Z	$\bar{G} = V_{IL}$	0	30	0	40	0	50	ns
t <sub>GHQZ</sub> <sup>(2)</sup>	t <sub>DF</sub>	Output Enable High to Output Hi-Z	$\bar{E} = V_{IL}$	0	30	0	40	0	50	ns
t <sub>AXQX</sub>	t <sub>OH</sub>	Address Transition to Output Transition	$\bar{E} = V_{IL}, \bar{G} = V_{IL}$	5		5		5		ns
t <sub>BLQX</sub>	t <sub>OH</sub>	BYTE Low to Output Transition	$\bar{E} = V_{IL}, \bar{G} = V_{IL}$	5		5		5		ns

Note: 1. V<sub>CC</sub> must be applied simultaneously with or before V<sub>PP</sub> and removed simultaneously or after V<sub>PP</sub>.

2. Sampled only, not 100% tested.

3. Speed obtained with High Speed AC measurement conditions.

**Figure 7. Word-Wide Read Mode AC Waveforms**Note: BYTE V<sub>PP</sub> = V<sub>IH</sub>.

Figure 8. Byte-Wide Read Mode AC Waveforms



Note:  $\overline{BYTEV_{PP}} = V_{IL}$ .

Figure 9. BYTE Transition AC Waveforms

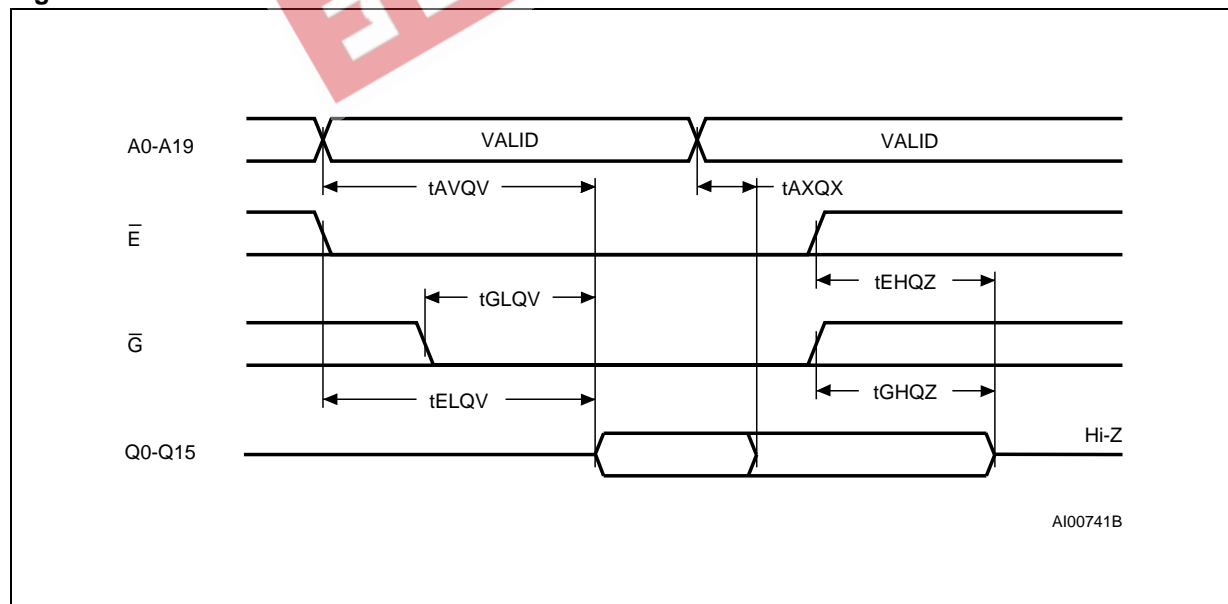
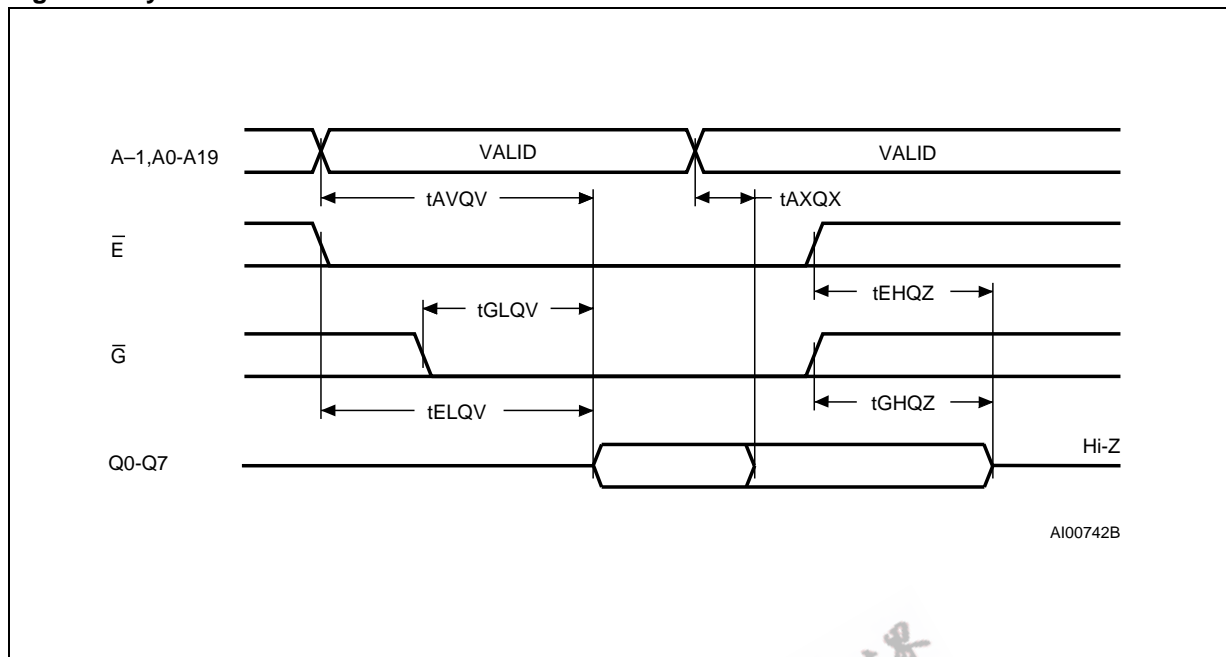
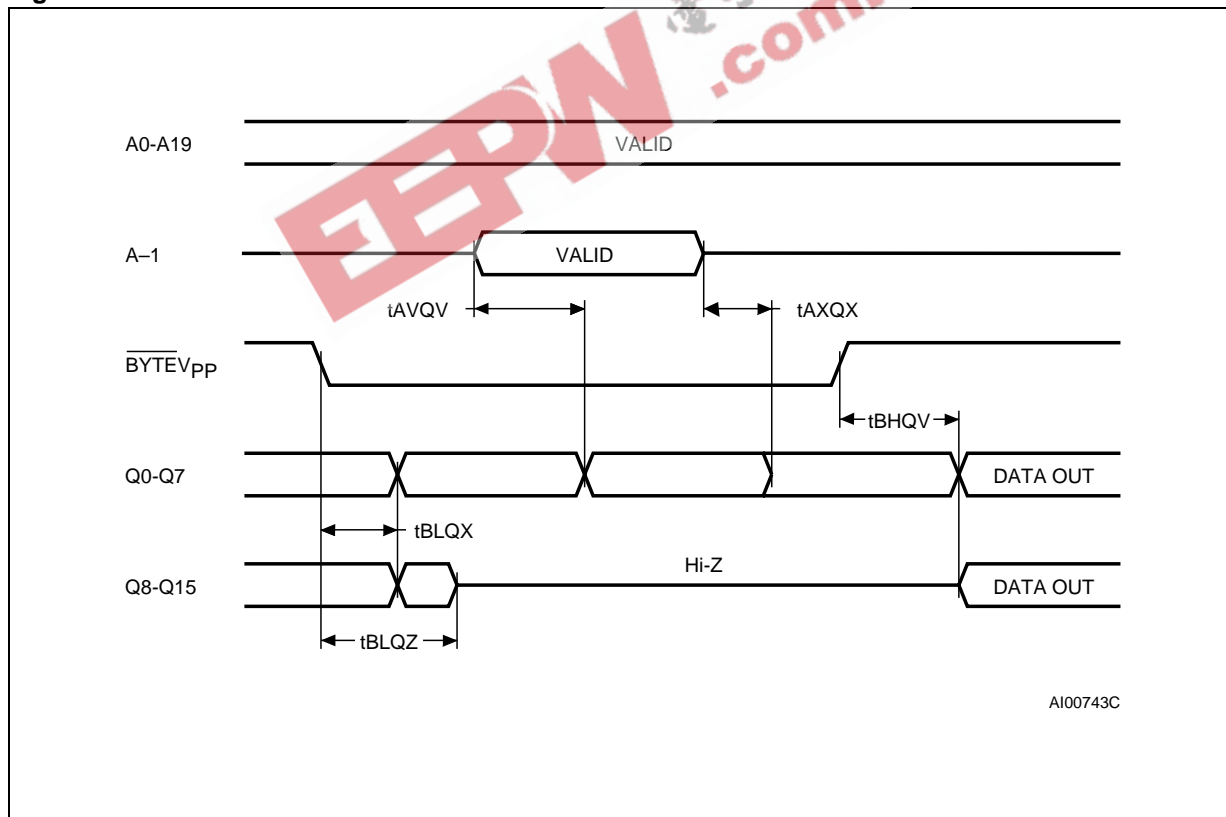

Note: Chip Enable (E-bar) and Output Enable (G-bar) =  $V_{IL}$ .



**Table 10. Programming Mode DC Characteristics (1)**  
 ( $T_A = 25\text{ }^\circ\text{C}$ ;  $V_{CC} = 6.25\text{V} \pm 0.25\text{V}$ ;  $V_{PP} = 12.5\text{V} \pm 0.25\text{V}$ )

Symbol	Parameter	Test Condition	Min	Max	Unit
$I_{LI}$	Input Leakage Current	$0 \leq V_{IN} \leq V_{CC}$		$\pm 1$	$\mu\text{A}$
$I_{CC}$	Supply Current			50	mA
$I_{PP}$	Program Current	$\bar{E} = V_{IL}$		50	mA
$V_{IL}$	Input Low Voltage		-0.3	0.8	V
$V_{IH}$	Input High Voltage		2.4	$V_{CC} + 0.5$	V
$V_{OL}$	Output Low Voltage	$I_{OL} = 2.1\text{mA}$		0.4	V
$V_{OH}$	Output High Voltage TTL	$I_{OH} = -2.5\text{mA}$	3.5		V
$V_{ID}$	A9 Voltage		11.5	12.5	V

Note: 1.  $V_{CC}$  must be applied simultaneously with or before  $V_{PP}$  and removed simultaneously or after  $V_{PP}$ .

**Table 11. Programming Mode AC Characteristics (1)**  
 ( $T_A = 25\text{ }^\circ\text{C}$ ;  $V_{CC} = 6.25\text{V} \pm 0.25\text{V}$ ;  $V_{PP} = 12.5\text{V} \pm 0.25\text{V}$ )

Symbol	Alt	Parameter	Test Condition	Min	Max	Unit
$t_{AVEL}$	$t_{AS}$	Address Valid to Chip Enable Low		2		$\mu\text{s}$
$t_{QVEL}$	$t_{DS}$	Input Valid to Chip Enable Low		2		$\mu\text{s}$
$t_{VPHAV}$	$t_{VPS}$	$V_{PP}$ High to Address Valid		2		$\mu\text{s}$
$t_{VCHAV}$	$t_{VCS}$	$V_{CC}$ High to Address Valid		2		$\mu\text{s}$
$t_{ELEH}$	$t_{PW}$	Chip Enable Program Pulse Width		45	55	$\mu\text{s}$
$t_{EHQX}$	$t_{DH}$	Chip Enable High to Input Transition		2		$\mu\text{s}$
$t_{QXGL}$	$t_{OES}$	Input Transition to Output Enable Low		2		$\mu\text{s}$
$t_{GLQV}$	$t_{OE}$	Output Enable Low to Output Valid			120	ns
$t_{GHQZ}^{(2)}$	$t_{DFP}$	Output Enable High to Output Hi-Z		0	130	ns
$t_{GHAX}$	$t_{AH}$	Output Enable High to Address Transition		0		ns

Note: 1.  $V_{CC}$  must be applied simultaneously with or before  $V_{PP}$  and removed simultaneously or after  $V_{PP}$ .

2. Sampled only, not 100% tested.

## Programming

When delivered (and after each erasure for UV EPROM), all bits of the M27C160 are in the '1' state. Data is introduced by selectively programming '0's into the desired bit locations. Although only '0's will be programmed, both '1's and '0's can be present in the data word. The only way to change a '0' to a '1' is by die exposure to ultraviolet

light (UV EPROM). The M27C160 is in the programming mode when  $V_{PP}$  input is at 12.5V, G is at  $V_{IH}$  and  $\bar{E}$  is pulsed to  $V_{IL}$ . The data to be programmed is applied to 16 bits in parallel to the data output pins. The levels required for the address and data inputs are TTL.  $V_{CC}$  is specified to be  $6.25\text{V} \pm 0.25\text{V}$ .

Figure 10. Programming and Verify Modes AC Waveforms

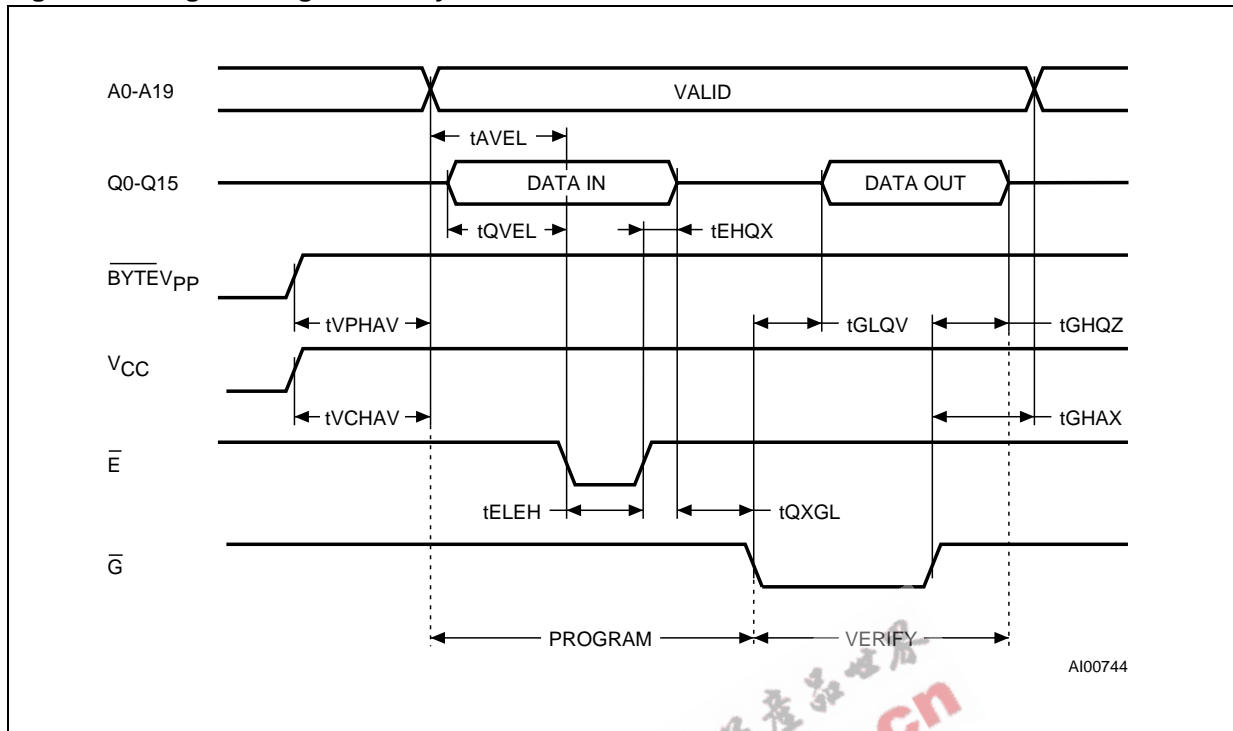
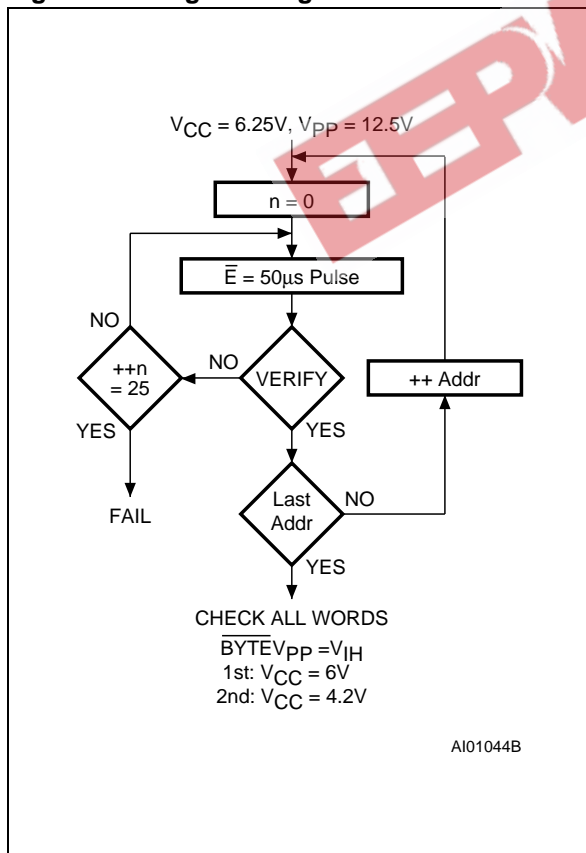

Figure 11. Programming Flowchart



**PRESTO III Programming Algorithm**

The PRESTO III Programming Algorithm allows the whole array to be programmed with a guaranteed margin in a typical time of 52.5 seconds. Programming with PRESTO III consists of applying a sequence of 50µs program pulses to each word until a correct verify occurs (see Figure 11). During programming and verify operation a MARGIN MODE circuit is automatically activated to guarantee that each cell is programmed with enough margin. No overprogram pulse is applied since the verify in MARGIN MODE provides the necessary margin to each programmed cell.

**Program Inhibit**

Programming of multiple M27C160s in parallel with different data is also easily accomplished. Except for  $\bar{E}$ , all like inputs including  $\bar{G}$  of the parallel M27C160 may be common. A TTL low level pulse applied to a M27C160's  $\bar{E}$  input and V<sub>PP</sub> at 12.5V, will program that M27C160. A high level  $\bar{E}$  input inhibits the other M27C160s from being programmed.

**Program Verify**

A verify (read) should be performed on the programmed bits to determine that they were correctly programmed. The verify is accomplished with  $\bar{E}$  at V<sub>IH</sub> and  $\bar{G}$  at V<sub>IL</sub>, V<sub>PP</sub> at 12.5V and V<sub>CC</sub> at 6.25V.



### Electronic Signature

The Electronic Signature (ES) mode allows the reading out of a binary code from an EPROM that will identify its manufacturer and type. This mode is intended for use by programming equipment to automatically match the device to be programmed with its corresponding programming algorithm. The ES mode is functional in the  $25^{\circ}\text{C} \pm 5^{\circ}\text{C}$  ambient temperature range that is required when programming the M27C160. To activate the ES mode, the programming equipment must force 11.5V to 12.5V on address line A9 of the M27C160, with  $V_{PP} = V_{CC} = 5\text{V}$ . Two identifier bytes may then be sequenced from the device outputs by toggling address line A0 from  $V_{IL}$  to  $V_{IH}$ . All other address lines must be held at  $V_{IL}$  during Electronic Signature mode. Byte 0 ( $A0 = V_{IL}$ ) represents the manufacturer code and byte 1 ( $A0 = V_{IH}$ ) the device identifier code. For the ST-Microelectronics M27C160, these two identifier bytes are given in Table 4 and can be read-out on outputs Q7 to Q0.

### ERASURE OPERATION (applies to UV EPROM)

The erasure characteristics of the M27C160 is such that erasure begins when the cells are exposed to light with wavelengths shorter than approximately 4000 Å. It should be noted that sunlight and some type of fluorescent lamps have wavelengths in the 3000-4000 Å range. Research shows that constant exposure to room level fluorescent lighting could erase a typical M27C160 in about 3 years, while it would take approximately 1 week to cause erasure when exposed to direct sunlight. If the M27C160 is to be exposed to these types of lighting conditions for extended periods of time, it is suggested that opaque labels be put over the M27C160 window to prevent unintentional erasure. The recommended erasure procedure for M27C160 is exposure to short wave ultraviolet light which has a wavelength of 2537 Å. The integrated dose (i.e. UV intensity x exposure time) for erasure should be a minimum of 30 W-sec/cm<sup>2</sup>. The erasure time with this dosage is approximately 30 to 40 minutes using an ultraviolet lamp with 12000 μW/cm<sup>2</sup> power rating. The M27C160 should be placed within 2.5cm (1 inch) of the lamp tubes during the erasure. Some lamps have a filter on their tubes which should be removed before erasure.

## M27C160

**Table 12. Ordering Information Scheme**

Example:	M27C160	-70	X	M	1	TR
<b>Device Type</b> M27						
<b>Supply Voltage</b> C = 5V						
<b>Device Function</b> 160 = 16 Mbit (2mb x 8 or 1Mb x 16)						
<b>Speed</b> -50 <sup>(1)</sup> = 50 ns -70 <sup>(1)</sup> = 70 ns -90 = 90 ns -100 = 100 ns -120 = 120 ns -150 = 150 ns						
<b>V<sub>CC</sub> Tolerance</b> blank = ± 10% X = ± 5%						
<b>Package</b> F = FDIP42W B = PDIP42 S = SDIP42 K = PLCC44 M = SO44						
<b>Temperature Range</b> 1 = 0 to 70 °C 6 = -40 to 85 °C						
<b>Options</b> TR = Tape & Reel Packing						

Note: 1. High Speed, see AC Characteristics section for further information.

For a list of available options (Speed, Package, etc...) or for further information on any aspect of this device, please contact the STMicroelectronics Sales Office nearest to you.

Table 13. Revision History

Date	Version	Revision Details
January 1999	-01	First Issue
20-Sep-00	-02	AN620 Reference removed
19-Jul-01	-03	SDIP42 package added
17-Jan-02	-04	50ns speed class added, SO44 package mechanical data and drawing clarified

EEPW 电子產品世界  
.com.cn

Table 14. FDIP42W - 42 pin Ceramic Frit-seal DIP, with window, Package Mechanical Data

Symbol	mm			inches		
	Typ	Min	Max	Typ	Min	Max
A			5.72			0.225
A1		0.51	1.40		0.020	0.055
A2		3.91	4.57		0.154	0.180
A3		3.89	4.50		0.153	0.177
B		0.41	0.56		0.016	0.022
B1	1.45	–	–	0.057	–	–
C		0.23	0.30		0.009	0.012
D		54.41	54.86		2.142	2.160
D2	50.80	–	–	2.000	–	–
E	15.24	–	–	0.600	–	–
E1		14.50	14.90		0.571	0.587
e	2.54	–	–	0.100	–	–
eA	14.99	–	–	0.590	–	–
eB		16.18	18.03		0.637	0.710
L		3.18			0.125	
S		1.52	2.49		0.060	0.098
K	9.40	–	–	0.370	–	–
K1	11.43	–	–	0.450	–	–
$\alpha$		4°	11°		4°	11°
N		42			42	

Figure 12. FDIP42W - 42 pin Ceramic Frit-seal DIP, with window, Package Outline

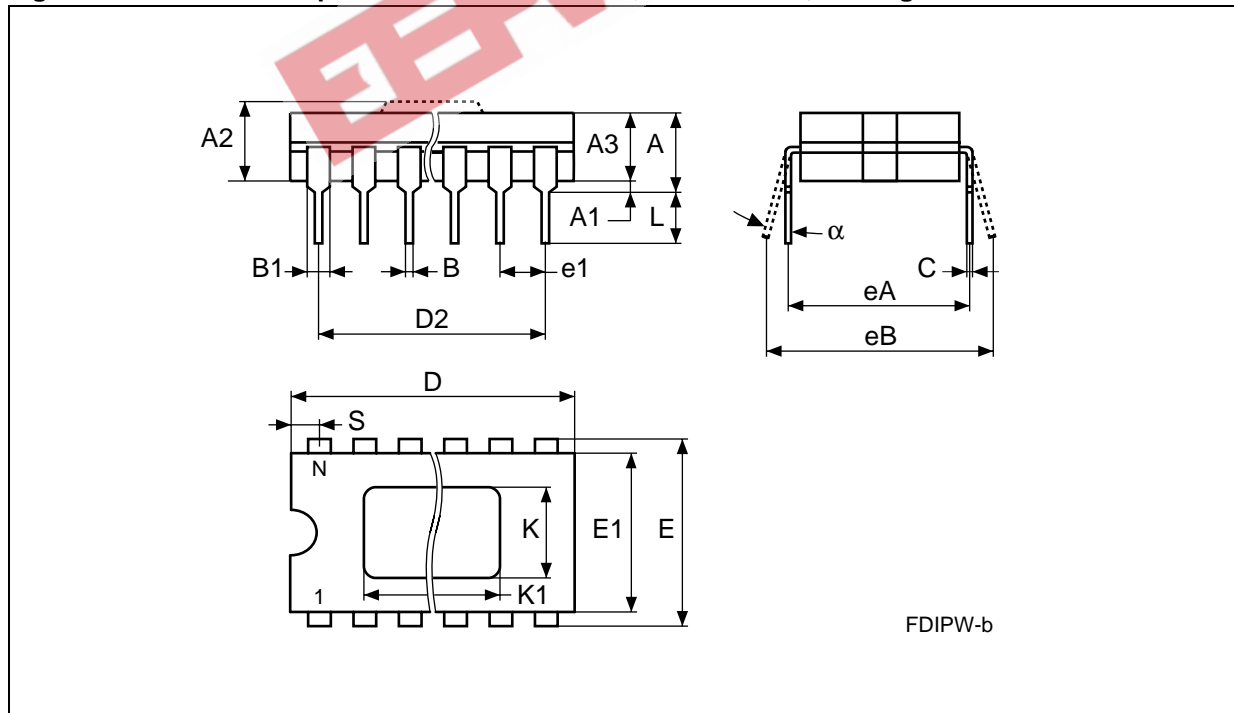

Drawing is not to scale.

Table 15. PDIP42 - 42 pin Plastic Dual In Line, 600 mils width, Package Mechanical Data

Symbol	mm			inches		
	Typ	Min	Max	Typ	Min	Max
A		–	5.08		–	0.200
A1		0.25	–		0.010	–
A2		3.56	4.06		0.140	0.160
B		0.38	0.53		0.015	0.021
B1		1.27	1.65		0.050	0.065
C		0.20	0.36		0.008	0.014
D		52.20	52.71		2.055	2.075
D2	50.80	–	–	2.000	–	–
E	15.24	–	–	0.600	–	–
E1		13.59	13.84		0.535	0.545
e1	2.54	–	–	0.100	–	–
eA	14.99	–	–	0.590	–	–
eB		15.24	17.78		0.600	0.700
L		3.18	3.43		0.125	0.135
S		0.86	1.37		0.034	0.054
$\alpha$		0°	10°		0°	10°
N		42			42	

Figure 13. PDIP42 - 42 pin Plastic Dual In Line, 600 mils width, Package Outline

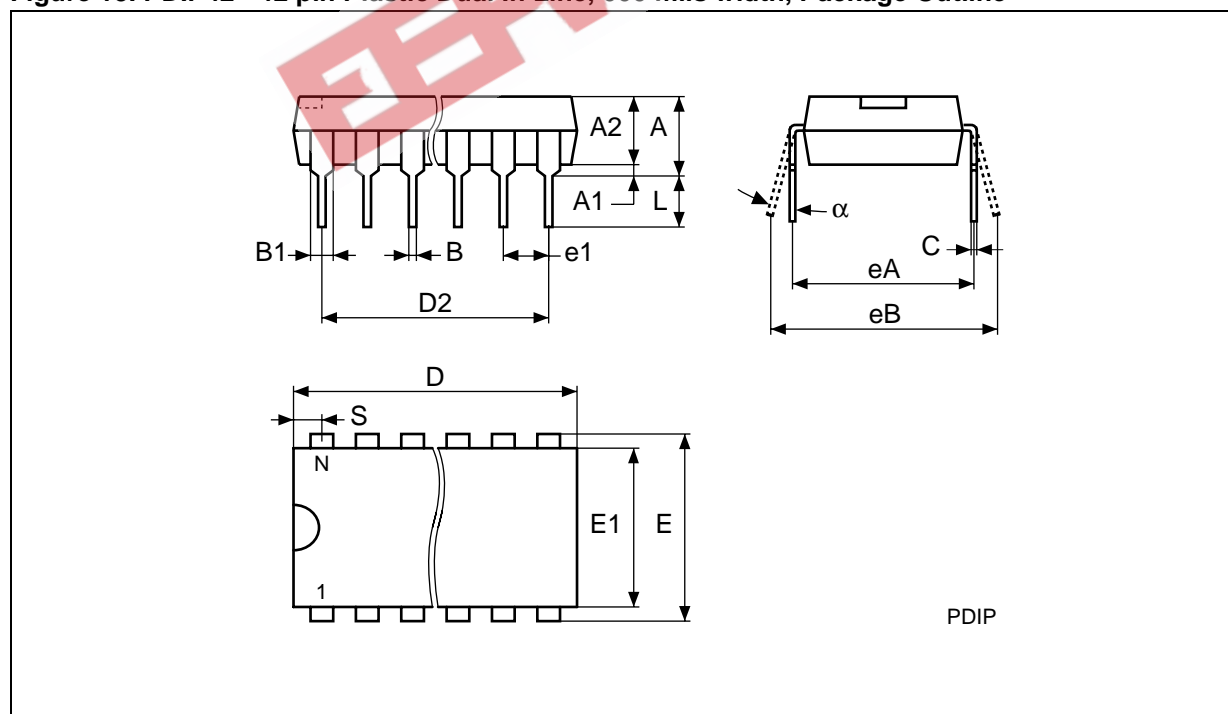

Drawing is not to scale.

M27C160

Table 16. SDIP42 - 42 pin Shrink Plastic DIP, 600 mils width, Package Mechanical Data

Symbol	millimeters			inches		
	Typ	Min	Max	Typ	Min	Max
A			5.08			0.200
A1		0.51			0.020	
A2	3.81	3.05	4.57	0.150	0.120	0.180
b	0.46	0.38	0.56	0.018	0.015	0.022
b2	1.02	0.89	1.14	0.040	0.035	0.045
c	0.25	0.23	0.38	0.010	0.009	0.015
D	36.83	36.58	37.08	1.450	1.440	1.460
e	1.78	–	–	0.070	–	–
E		15.24	16.00		0.600	0.630
E1	13.72	12.70	14.48	0.540	0.500	0.570
eA	15.24	–	–	0.600	–	–
eB			18.54			0.730
L	3.30	2.54	3.56	0.130	0.100	0.140
S	0.64			0.025		
N		42			42	

Figure 14. SDIP42 - 42 pin Shrink Plastic DIP, 600 mils width, Package Outline

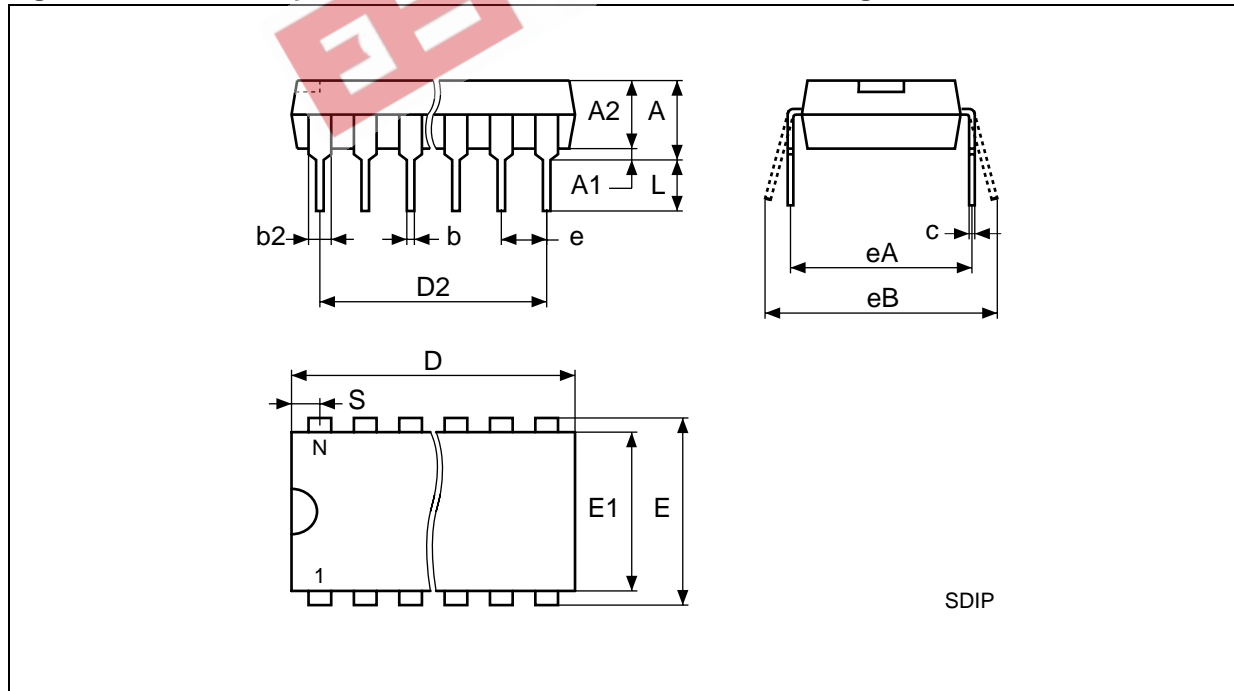

Drawing is not to scale.



Table 17. PLCC44 - 44 lead Plastic Leaded Chip Carrier, Package Mechanical Data

Symbol	mm			inches		
	Typ	Min	Max	Typ	Min	Max
A		4.20	4.70		0.165	0.185
A1		2.29	3.04		0.090	0.120
A2		–	0.51		–	0.020
B		0.33	0.53		0.013	0.021
B1		0.66	0.81		0.026	0.032
D		17.40	17.65		0.685	0.695
D1		16.51	16.66		0.650	0.656
D2		14.99	16.00		0.590	0.630
E		17.40	17.65		0.685	0.695
E1		16.51	16.66		0.650	0.656
E2		14.99	16.00		0.590	0.630
e	1.27	–	–	0.050	–	–
F		0.00	0.25		0.000	0.010
R	0.89	–	–	0.035	–	–
N		44			44	
CP			0.10			0.004

Figure 15. PLCC44 - 44 lead Plastic Leaded Chip Carrier, Package Outline

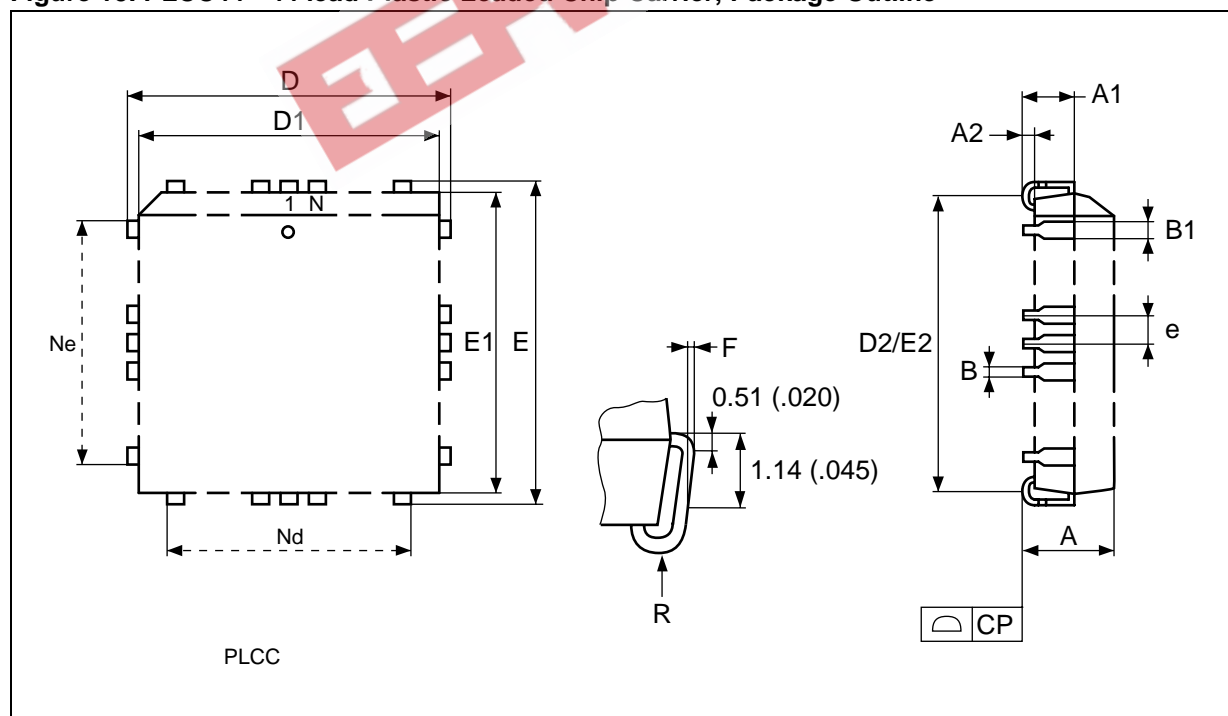

Drawing is not to scale.

M27C160

Table 18. SO44 - 44 lead Plastic Small Outline, 525 mils body width, Package Mechanical Data

Symbol	Typ	millimeters		Typ	inches	
		Min	Max		Min	Max
A			2.80			0.1102
A1		0.10			0.0039	
A2	2.30	2.20	2.40	0.0906	0.0866	0.0945
b	0.40	0.35	0.50	0.0157	0.0138	0.0197
C	0.15	0.10	0.20	0.0059	0.0039	0.0079
CP			0.08			0.0030
D	28.20	28.00	28.40	1.1102	1.1024	1.1181
E	13.30	13.20	13.50	0.5236	0.5197	0.5315
e	1.27	–	–	0.0500	–	–
HE	16.00	15.75	16.25	0.6299	0.6201	0.6398
L	0.80			0.0315		
N		44			44	
$\alpha$			8°			8°

Figure 16. SO44 - 44 lead Plastic Small Outline, 525 mils body width, Package Outline

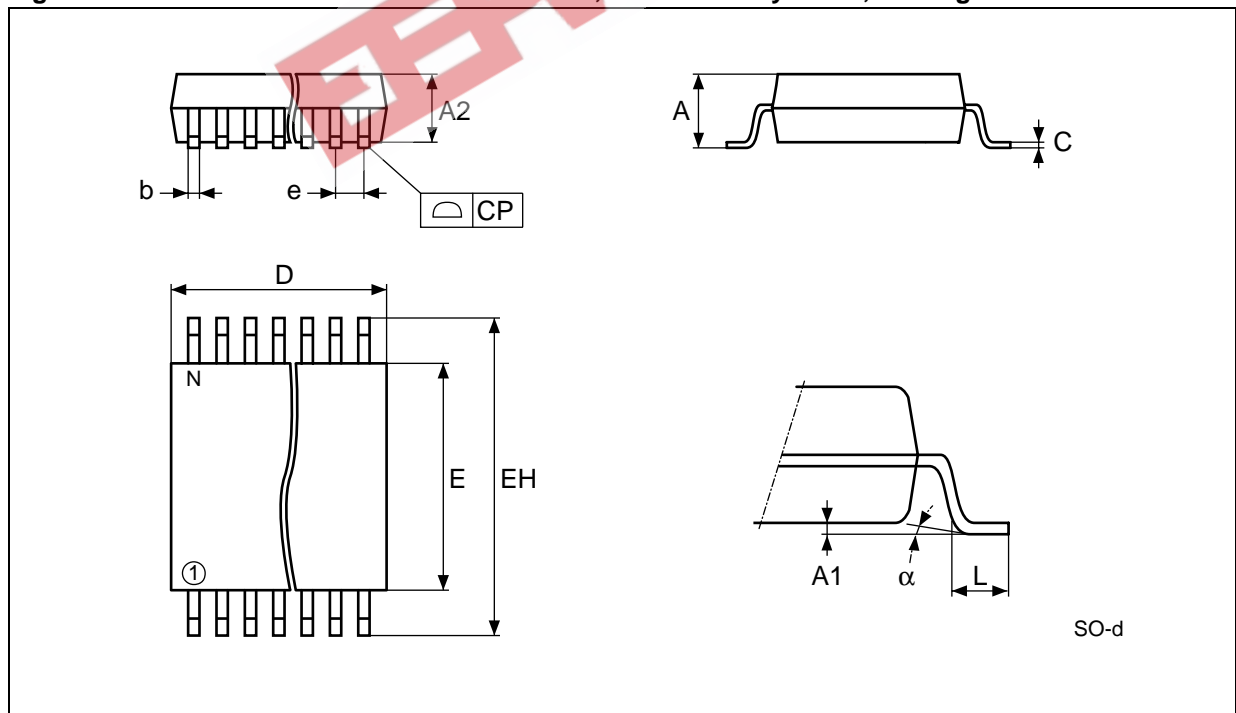

Drawing is not to scale.

EEPW 电子产品世界  
.com.cn

Information furnished is believed to be accurate and reliable. However, STMicroelectronics assumes no responsibility for the consequences of use of such information nor for any infringement of patents or other rights of third parties which may result from its use. No license is granted by implication or otherwise under any patent or patent rights of STMicroelectronics. Specifications mentioned in this publication are subject to change without notice. This publication supersedes and replaces all information previously supplied. STMicroelectronics products are not authorized for use as critical components in life support devices or systems without express written approval of STMicroelectronics.

The ST logo is registered trademark of STMicroelectronics  
All other names are the property of their respective owners

© 2002 STMicroelectronics - All Rights Reserved

STMicroelectronics GROUP OF COMPANIES

Australia - Brazil - Canada - China - Finland - France - Germany - Hong Kong - India - Israel - Italy - Japan - Malaysia - Malta -  
Morocco - Singapore - Spain - Sweden - Switzerland - United Kingdom - United States

[www.st.com](http://www.st.com)