



M28W320EBT M28W320EBB

32 Mbit (2Mb x16, Boot Block)
3V Supply Flash Memory

PRELIMINARY DATA

FEATURES SUMMARY

- SUPPLY VOLTAGE
 - V_{DD} = 2.7V to 3.6V Core Power Supply
 - V_{DDQ} = 1.65V to 3.6V for Input/Output
 - V_{PP} = 12V for fast Program (optional)
- ACCESS TIME: 70, 85, 90,100ns
- PROGRAMMING TIME
 - 10 μ s typical
 - Double Word Programming Option
 - Quadruple Word Programming Option
- COMMON FLASH INTERFACE
- MEMORY BLOCKS
 - Parameter Blocks (Top or Bottom location)
 - Main Blocks
- BLOCK PROTECTION on TWO PARAMETER BLOCKS
 - \overline{WP} for Block Protection
- AUTOMATIC STAND-BY MODE
- PROGRAM and ERASE SUSPEND
- 100,000 PROGRAM/ERASE CYCLES per BLOCK
- ELECTRONIC SIGNATURE
 - Manufacturer Code: 20h
 - Top Device Code, M28W320EBT: 88BCh
 - Bottom Device Code, M28W320EBB: 88BDh

Figure 1. Packages



TABLE OF CONTENTS

SUMMARY DESCRIPTION **5**

- Figure 2. Logic Diagram 5
- Table 1. Signal Names 5
- Figure 3. TSOP Connections. 6
- Figure 4. TFBGA Connections (Top view through package) 7
- Figure 5. Block Addresses. 8

SIGNAL DESCRIPTIONS **9**

- Address Inputs (A0-A20). 9
- Data Input/Output (DQ0-DQ15). 9
- Chip Enable (E). 9
- Output Enable (G). 9
- Write Enable (W). 9
- Write Protect (WP). 9
- Reset (RP). 9
- V_{DD} Supply Voltage. 9
- V_{DDQ} Supply Voltage. 9
- V_{PP} Program Supply Voltage 9
- V_{SS} Ground. 9

BUS OPERATIONS. **10**

- Read. 10
- Write. 10
- Output Disable. 10
- Standby. 10
- Automatic Standby. 10
- Reset. 10
- Table 2. Bus Operations 10

COMMAND INTERFACE **11**

- Read Memory Array command 11
- Read Status Register Command. 11
- Read Electronic Signature Command 11
- Table 3. Command Codes. 11
- Read CFI Query Command. 11
- Block Erase Command 11
- Program Command 12
- Double Word Program Command 12
- Clear Status Register Command. 12
- Program/Erase Suspend Command 12
- Program/Erase Resume Command 13
- Block Protection. 13
- Table 4. Commands 14
- Table 5. Read Electronic Signature. 14



Table 6. Memory Blocks Protection Truth Table	15
Table 7. Program, Erase Times and Program/Erase Endurance Cycles	15
STATUS REGISTER	16
Program/Erase Controller Status (Bit 7)	16
Erase Suspend Status (Bit 6)	16
Erase Status (Bit 5)	16
Program Status (Bit 4)	16
V _{PP} Status (Bit 3)	16
Program Suspend Status (Bit 2)	16
Block Protection Status (Bit 1)	17
Reserved (Bit 0)	17
Table 8. Status Register Bits	17
MAXIMUM RATING	18
Table 9. Absolute Maximum Ratings	18
DC and AC PARAMETERS	19
Table 10. Operating and AC Measurement Conditions	19
Figure 6. AC Measurement I/O Waveform	19
Figure 7. AC Measurement Load Circuit	19
Table 11. Device Capacitance	19
Table 12. DC Characteristics	20
Figure 8. Read AC Waveforms	21
Table 13. Read AC Characteristics	21
Figure 9. Write AC Waveforms, Write Enable Controlled	22
Table 14. Write AC Characteristics, Write Enable Controlled	23
Figure 10. Write AC Waveforms, Chip Enable Controlled	24
Table 15. Write AC Characteristics, Chip Enable Controlled	25
Figure 11. Power-Up and Reset AC Waveforms	26
Table 16. Power-Up and Reset AC Characteristics	26
PACKAGE MECHANICAL	27
Figure 12. TSOP48 - 48 lead Plastic Thin Small Outline, 12 x 20mm, Package Outline	27
Table 17. TSOP48 - 48 lead Plastic Thin Small Outline, 12 x 20mm, Package Mechanical Data	27
Figure 13. TFBGA47 6.39x6.37mm - 8x6 ball array, 0.75mm pitch, Bottom View Package Outline	28
Table 18. TFBGA47 6.39x6.37mm - 8x6 ball array, 0.75mm pitch, Package Mechanical Data	28
Figure 14. TFBGA47 Daisy Chain - Package Connections (Top view through package)	29
Figure 15. TFBGA47 Daisy Chain - PCB Connections proposal (Top view through package)	29
PART NUMBERING	30
Table 19. Ordering Information Scheme	30
Table 20. Daisy Chain Ordering Scheme	30
APPENDIX A. BLOCK ADDRESS TABLES	31

Table 21. Top Boot Block Addresses, M28W320EBT	31
Table 22. Bottom Boot Block Addresses, M28W320EBB	32
APPENDIX B. COMMON FLASH INTERFACE (CFI)	33
Table 23. Query Structure Overview	33
Table 24. CFI Query Identification String	33
Table 25. CFI Query System Interface Information	34
Table 26. Device Geometry Definition	35
Table 27. Primary Algorithm-Specific Extended Query Table	36
Table 28. Security Code Area	36
APPENDIX C. FLOWCHARTS AND PSEUDO CODES	37
Figure 16. Program Flowchart and Pseudo Code	37
Figure 17. Double Word Program Flowchart and Pseudo Code	38
Figure 19. Program Suspend & Resume Flowchart and Pseudo Code	40
Figure 20. Erase Flowchart and Pseudo Code	41
Figure 21. Erase Suspend & Resume Flowchart and Pseudo Code	42
APPENDIX D. COMMAND INTERFACE AND PROGRAM/ERASE CONTROLLER STATE	43
Table 29. Write State Machine Current/Next	43
REVISION HISTORY	44
Table 30. Document Revision History	44

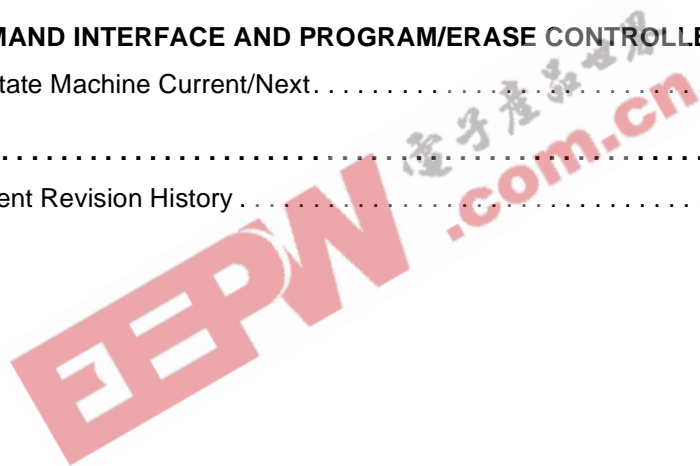

SUMMARY DESCRIPTION

The M28W320EB is a 32 Mbit (2 Mbit x 16) non-volatile Flash memory that can be erased electrically at the block level and programmed in-system on a Word-by-Word basis. These operations can be performed using a single low voltage (2.7 to 3.6V) supply. V_{DDQ} allows to drive the I/O pin down to 1.65V. An optional 12V V_{PP} power supply is provided to speed up customer programming.

The device features an asymmetrical blocked architecture. The M28W320EB has an array of 71 blocks: 8 Parameter Blocks of 4 KWord and 63 Main Blocks of 32 KWord. M28W320EBT has the Parameter Blocks at the top of the memory address space while the M28W320EBB locates the Parameter Blocks starting from the bottom. The memory maps are shown in Figure 5, Block Addresses.

Parameter blocks 0 and 1 can be protected from accidental programming or erasure. Each block can be erased separately. Erase can be suspended in order to perform either read or program in any other block and then resumed. Program can be suspended to read data in any other block and then resumed. Each block can be programmed and erased over 100,000 cycles.

Program and Erase commands are written to the Command Interface of the memory. An on-chip Program/Erase Controller takes care of the timings necessary for program and erase operations. The end of a program or erase operation can be detected and any error conditions identified. The command set required to control the memory is consistent with JEDEC standards.

The memory is offered in TSOP48 (10 X 20mm), and TFBGA47 (6.39 x 6.37mm, 0.75mm pitch) packages and is supplied with all the bits erased (set to '1').

Figure 2. Logic Diagram

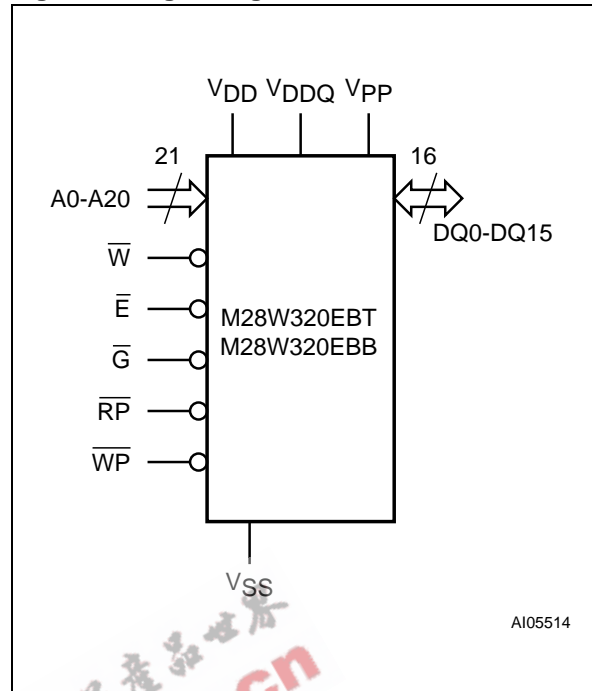
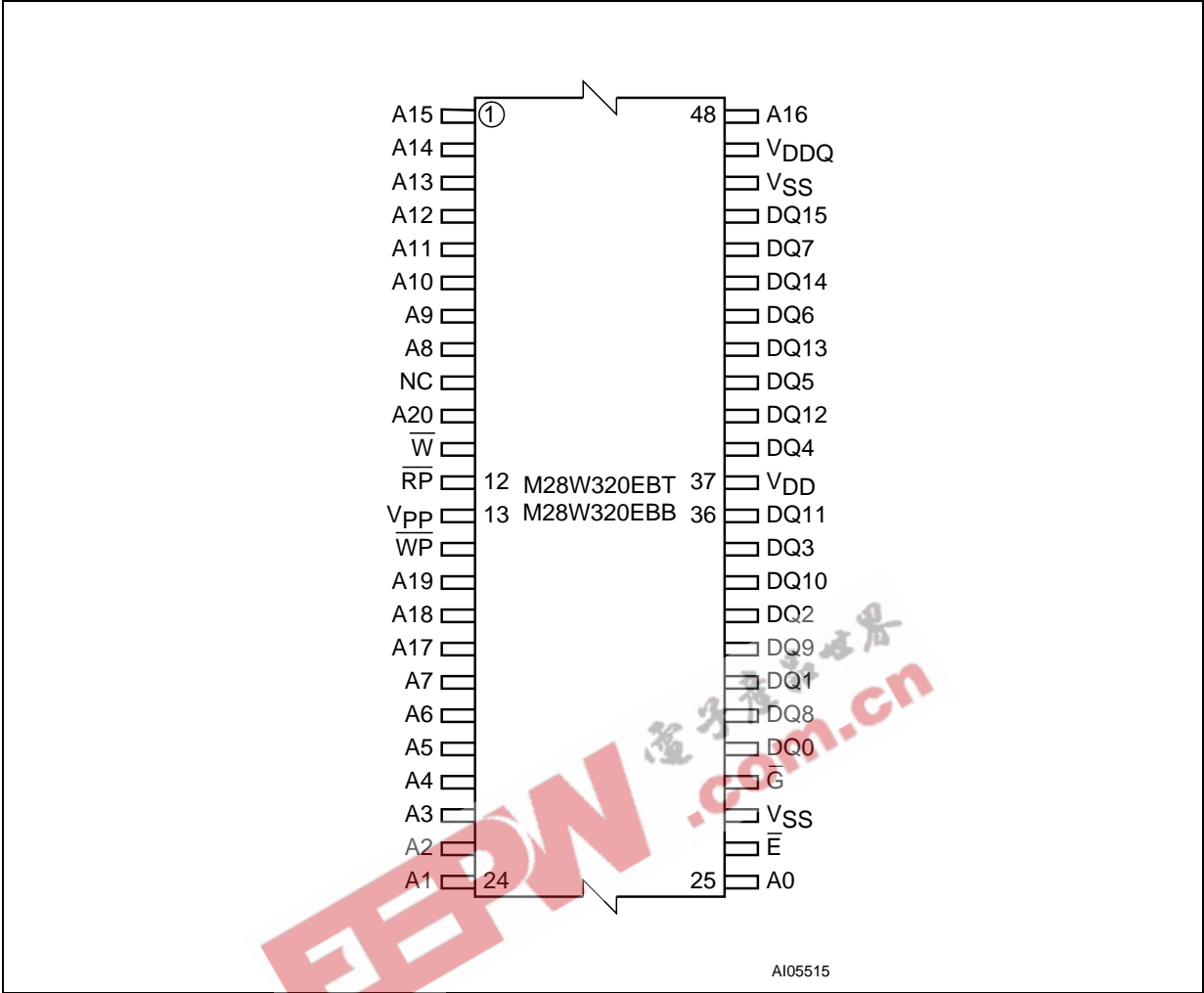

Table 1. Signal Names

A0-A20	Address Inputs
DQ0-DQ15	Data Input/Output
\bar{E}	Chip Enable
\bar{G}	Output Enable
\bar{W}	Write Enable
\overline{RP}	Reset
\overline{WP}	Write Protect
V_{DD}	Core Power Supply
V_{DDQ}	Power Supply for Input/Output
V_{PP}	Optional Supply Voltage for Fast Program & Erase
V_{SS}	Ground

Figure 3. TSOP Connections



AI05515

Figure 4. TFBGA Connections (Top view through package)

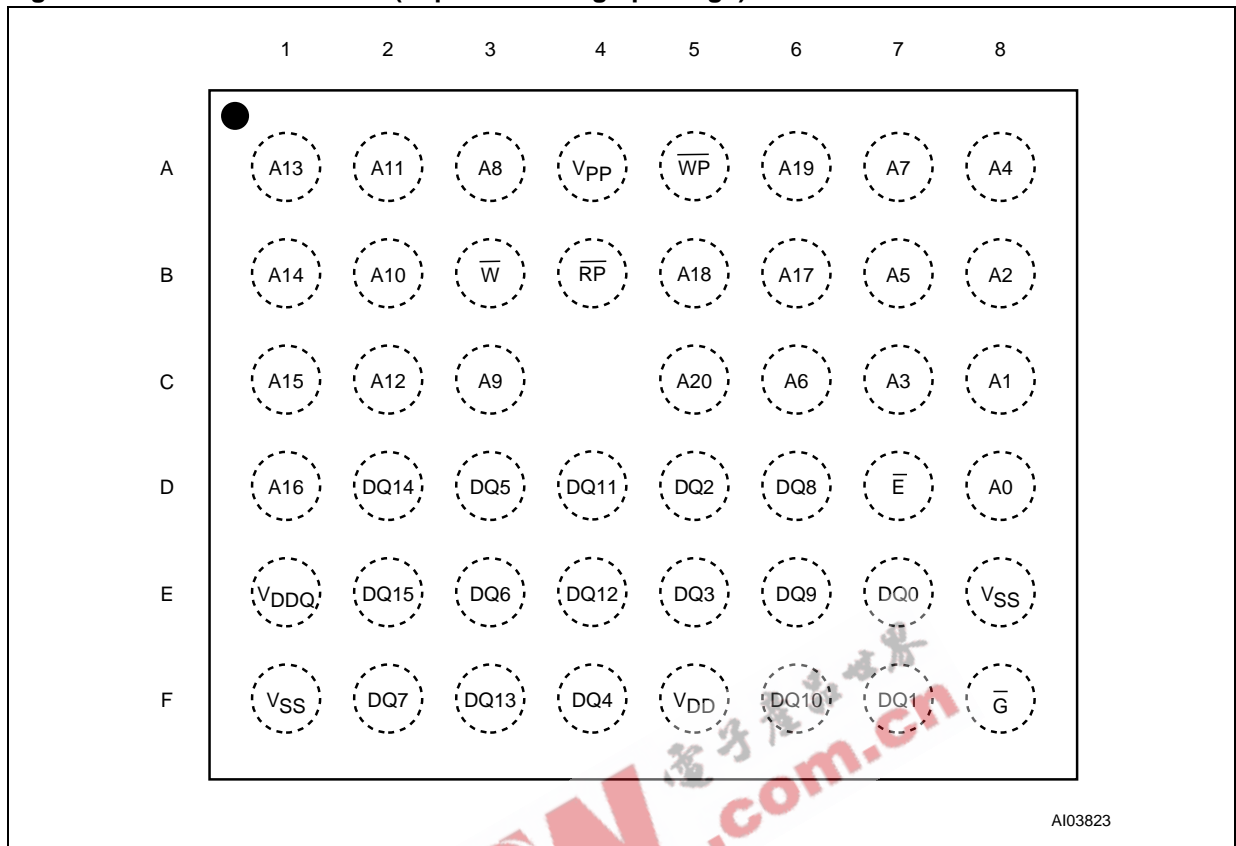
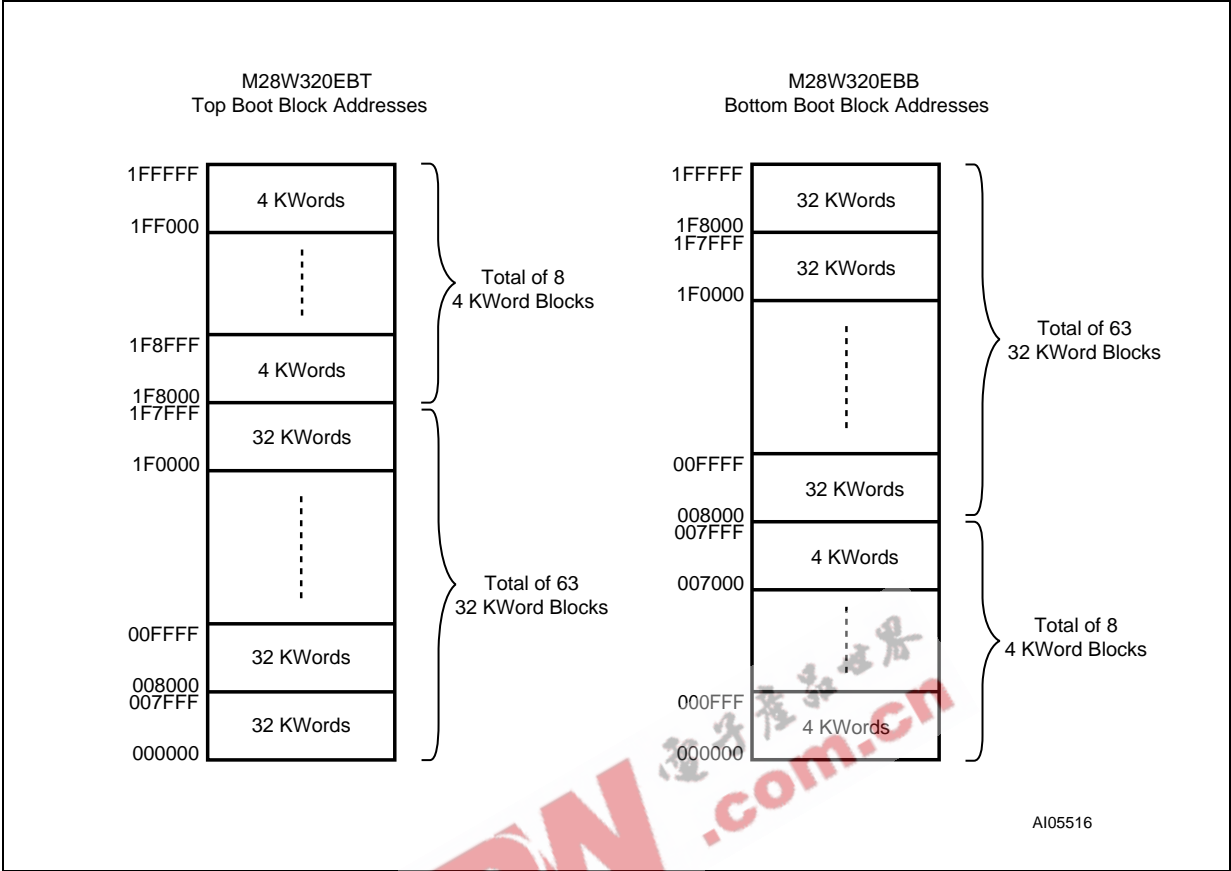

Figure 5. Block Addresses



Note: Also see Appendix A, Tables 21 and 22 for a full listing of the Block Addresses.



SIGNAL DESCRIPTIONS

See Figure 2 Logic Diagram and Table 1, Signal Names, for a brief overview of the signals connected to this device.

Address Inputs (A0-A20). The Address Inputs select the cells in the memory array to access during Bus Read operations. During Bus Write operations they control the commands sent to the Command Interface of the internal state machine.

Data Input/Output (DQ0-DQ15). The Data I/O outputs the data stored at the selected address during a Bus Read operation or inputs a command or data to be programmed during a Write Bus operation.

Chip Enable (\bar{E}). The Chip Enable input activates the memory control logic, input buffers, decoders and sense amplifiers. When Chip Enable is at V_{IL} and Reset is at V_{IH} the device is in active mode. When Chip Enable is at V_{IH} the memory is deselected, the outputs are high impedance and the power consumption is reduced to the stand-by level.

Output Enable (\bar{G}). The Output Enable controls data outputs during the Bus Read operation of the memory.

Write Enable (\bar{W}). The Write Enable controls the Bus Write operation of the memory's Command Interface. The data and address inputs are latched on the rising edge of Chip Enable, E, or Write Enable, \bar{W} , whichever occurs first.

Write Protect (\bar{WP}). Write Protect is an input to protect or unprotect the two lockable parameter blocks. When Write Protect is at V_{IL} , the lockable blocks are protected and Program or Erase operations are not possible. When Write Protect is at V_{IH} , the lockable blocks are unprotected and can be programmed or erased (refer to Table 5, Memory Blocks Protection Truth).

Reset (\bar{RP}). The Reset input provides a hardware reset of the memory. When Reset is at V_{IL} , the memory is in reset mode: the outputs are high impedance and the current consumption is minimized. When Reset is at V_{IH} , the device is in nor-

mal operation. Exiting reset mode the device enters read array mode, but a negative transition of Chip Enable or a change of the address is required to ensure valid data outputs.

V_{DD} Supply Voltage. V_{DD} provides the power supply to the internal core of the memory device. It is the main power supply for all operations (Read, Program and Erase).

V_{DDQ} Supply Voltage. V_{DDQ} provides the power supply to the I/O pins and enables all Outputs to be powered independently from V_{DD} . V_{DDQ} can be tied to V_{DD} or can use a separate supply.

V_{PP} Program Supply Voltage. V_{PP} is both a control input and a power supply pin. The two functions are selected by the voltage range applied to the pin. The Supply Voltage V_{DD} and the Program Supply Voltage V_{PP} can be applied in any order.

If V_{PP} is kept in a low voltage range (0V to 3.6V) V_{PP} is seen as a control input. In this case a voltage lower than V_{PPLK} gives an absolute protection against program or erase, while $V_{PP} > V_{PP1}$ enables these functions (see Table 12, DC Characteristics for the relevant values). V_{PP} is only sampled at the beginning of a Program or Erase; a change in its value after the operation has started does not have any effect on Program or Erase, however for Double or Quadruple Word Program the results are uncertain.

If V_{PP} is in the range 11.4V to 12.6V it acts as a power supply pin. In this condition V_{PP} must be stable until the Program/Erase algorithm is completed (see Table 14 and 15).

V_{SS} Ground. V_{SS} is the reference for all voltage measurements.

Note: Each device in a system should have V_{DD} , V_{DDQ} and V_{PP} decoupled with a 0.1 μ F capacitor close to the pin. See Figure 7, AC Measurement Load Circuit. The PCB trace widths should be sufficient to carry the required V_{PP} Program and Erase currents.

BUS OPERATIONS

There are six standard bus operations that control the device. These are Bus Read, Bus Write, Output Disable, Standby, Automatic Standby and Reset. See Table 2, Bus Operations, for a summary.

Typically glitches of less than 5ns on Chip Enable or Write Enable are ignored by the memory and do not affect bus operations.

Read. Read Bus operations are used to output the contents of the Memory Array, the Electronic Signature, the Status Register and the Common Flash Interface. Both Chip Enable and Output Enable must be at V_{IL} in order to perform a read operation. The Chip Enable input should be used to enable the device. Output Enable should be used to gate data onto the output. The data read depends on the previous command written to the memory (see Command Interface section). See Figure 8, Read Mode AC Waveforms, and Table 13, Read AC Characteristics, for details of when the output becomes valid.

Read mode is the default state of the device when exiting Reset or after power-up.

Write. Bus Write operations write Commands to the memory or latch Input Data to be programmed. A write operation is initiated when Chip Enable and Write Enable are at V_{IL} with Output Enable at V_{IH} . Commands, Input Data and Addresses are latched on the rising edge of Write Enable or Chip Enable, whichever occurs first.

See Figures 9 and 10, Write AC Waveforms, and Tables 14 and 15, Write AC Characteristics, for details of the timing requirements.

Output Disable. The data outputs are high impedance when the Output Enable is at V_{IH} .

Standby. Standby disables most of the internal circuitry allowing a substantial reduction of the current consumption. The memory is in stand-by when Chip Enable is at V_{IH} and the device is in read mode. The power consumption is reduced to the stand-by level and the outputs are set to high impedance, independently from the Output Enable or Write Enable inputs. If Chip Enable switches to V_{IH} during a program or erase operation, the device enters Standby mode when finished.

Automatic Standby. Automatic Standby provides a low power consumption state during Read mode. Following a read operation, the device enters Automatic Standby after 150ns of bus inactivity, even if Chip Enable is low, V_{IL} , and the supply current is reduced to I_{DD1} . The data Inputs/Outputs will still output data.

Reset. During Reset mode, when Output Enable is low, V_{IL} , the memory is deselected and the outputs are high impedance. The memory is in Reset mode when Reset is at V_{IL} . The power consumption is reduced to the Standby level, independently from the Chip Enable, Output Enable or Write Enable inputs. If Reset is pulled to V_{SS} during a Program or Erase, this operation is aborted and the memory content is no longer valid.

Table 2. Bus Operations

Operation	\bar{E}	\bar{G}	\bar{W}	\bar{RP}	\bar{WP}	V_{PP}	DQ0-DQ15
Read	V_{IL}	V_{IL}	V_{IH}	V_{IH}	X	Don't Care	Data Output
Write	V_{IL}	V_{IH}	V_{IL}	V_{IH}	X	V_{DD} or V_{PPH}	Data Input
Output Disable	V_{IL}	V_{IH}	V_{IH}	V_{IH}	X	Don't Care	Hi-Z
Standby	V_{IH}	X	X	V_{IH}	X	Don't Care	Hi-Z
Reset	X	X	X	V_{IL}	X	Don't Care	Hi-Z

Note: X = V_{IL} or V_{IH} , $V_{PPH} = 12V \pm 5\%$.

COMMAND INTERFACE

All Bus Write operations to the memory are interpreted by the Command Interface. Commands consist of one or more sequential Bus Write operations. An internal Program/Erase Controller handles all timings and verifies the correct execution of the Program and Erase commands. The Program/Erase Controller provides a Status Register whose output may be read at any time, to monitor the progress of an operation, or the Program/Erase states. See Table 3, Command Codes, for a summary of the commands and see Appendix D, Table 29, Write State Machine Current/Next, for a summary of the Command Interface.

The Command Interface is reset to Read mode when power is first applied, when exiting from Reset or whenever V_{DD} is lower than V_{LKO} . Command sequences must be followed exactly. Any invalid combination of commands will reset the device to Read mode. Refer to Table 4, Commands, in conjunction with the text descriptions below.

Read Memory Array command

The Read command returns the memory to its Read mode. One Bus Write cycle is required to issue the Read Memory Array command and return the memory to Read mode. Subsequent read operations will read the addressed location and output the data. When a device Reset occurs, the memory defaults to Read mode.

Read Status Register Command

The Status Register indicates when a program or erase operation is complete and the success or failure of the operation itself. Issue a Read Status Register command to read the Status Register's contents. Subsequent Bus Read operations read the Status Register, at any address, until another command is issued. See Table 8, Status Register Bits, for details on the definitions of the bits.

The Read Status Register command may be issued at any time, even during a Program/Erase operation. Any Read attempt during a Program/Erase operation will automatically output the content of the Status Register.

Read Electronic Signature Command

The Read Electronic Signature command reads the Manufacturer and Device Codes.

The Read Electronic Signature command consists of one write cycle, a subsequent read will output the Manufacturer or the Device Code depending on the levels of A0. The Manufacturer Code is output when the address line A0 is at V_{IL} , the Device Code is output when A0 is at V_{IH} . Addresses A1-A7 must be kept to V_{IL} , other addresses are ignored. The codes are output on DQ0-DQ7 with DQ8-DQ15 at 00h. (see Table 5)

Table 3. Command Codes

Hex Code	Command
10h	Program
20h	Erase
30h	Double Word Program
40h	Program
50h	Clear Status Register
55h	Reserved
56h	Quadruple Word Program
70h	Read Status Register
90h	Read Electronic Signature
98h	Read CFI Query
B0h	Program/Erase Suspend
D0h	Program/Erase Resume
FFh	Read Memory Array

Read CFI Query Command

The Read Query Command is used to read data from the Common Flash Interface (CFI) Memory Area, allowing programming equipment or applications to automatically match their interface to the characteristics of the device.

One Bus Write cycle is required to issue the Read Query Command. Once the command is issued subsequent Bus Read operations read from the Common Flash Interface Memory Area. See Appendix B, Common Flash Interface, Tables 23, 24, 25, 26, 27 and 28 for details on the information contained in the Common Flash Interface memory area.

Block Erase Command

The Block Erase command can be used to erase a block. It sets all the bits within the selected block to '1'. All previous data in the block is lost. If the block is protected then the Erase operation will abort, the data in the block will not be changed and the Status Register will output the error.

Two Bus Write cycles are required to issue the command.

- The first bus cycle sets up the Erase command.
- The second latches the block address in the internal state machine and starts the Program/Erase Controller.

If the second bus cycle is not Write Erase Confirm (D0h), Status Register bits b4 and b5 are set and the command aborts.

Erase aborts if Reset turns to V_{IL} . As data integrity cannot be guaranteed when the Erase operation is aborted, the block must be erased again.

During Erase operations the memory will only accept the Read Status Register command and the Program/Erase Suspend command, all other commands will be ignored. Typical Erase times are given in Table 7, Program, Erase Times and Program/Erase Endurance Cycles.

See Appendix C, Figure 20, Erase Flowchart and Pseudo Code, for the flowchart for using the Erase command.

Program Command

The memory array can be programmed word-by-word. Two bus write cycles are required to issue the Program command.

- The first bus cycle sets up the Program command.
- The second latches the Address and the Data to be written and starts the Program/Erase Controller.

During Program operations the memory will only accept the Read Status Register command and the Program/Erase Suspend command. All other commands will be ignored. Typical Program times are given in Table 7, Program, Erase Times and Program/Erase Endurance Cycles.

Programming aborts if Reset goes to V_{IL} . As data integrity cannot be guaranteed when the program operation is aborted, the block containing the memory location must be erased and reprogrammed.

See Appendix C, Figure 16, Program Flowchart and Pseudo Code, for the flowchart for using the Program command.

Double Word Program Command

This feature is offered to improve the programming throughput, writing a page of two adjacent words in parallel. The two words must differ only for the address A0. Programming should not be attempted when V_{PP} is not at V_{PPH} .

Three bus write cycles are necessary to issue the Double Word Program command.

- The first bus cycle sets up the Double Word Program command.
- The second bus cycle latches the Address and the Data of the first word to be written.
- The third bus cycle latches the Address and the Data of the second word to be written and starts the Program/Erase Controller.

Read operations output the Status Register content after the programming has started. Programming aborts if Reset goes to V_{IL} . As data integrity cannot be guaranteed when the program operation

is aborted, the block containing the memory location must be erased and reprogrammed.

See Appendix C, Figure 17, Double Word Program Flowchart and Pseudo Code, for the flowchart for using the Double Word Program command.

Quadruple Word Program Command

This feature is offered to improve the programming throughput, writing a page of four adjacent words in parallel. The four words must differ only for the addresses A0 and A1. Programming should not be attempted when V_{PP} is not at V_{PPH} .

Five bus write cycles are necessary to issue the Quadruple Word Program command.

- The first bus cycle sets up the Quadruple Word Program Command.
- The second bus cycle latches the Address and the Data of the first word to be written.
- The third bus cycle latches the Address and the Data of the second word to be written.
- The fourth bus cycle latches the Address and the Data of the third word to be written.
- The fifth bus cycle latches the Address and the Data of the fourth word to be written and starts the Program/Erase Controller.

Read operations output the Status Register content after the programming has started. Programming aborts if Reset goes to V_{IL} . As data integrity cannot be guaranteed when the program operation is aborted, the block containing the memory location must be erased and reprogrammed.

See Appendix C, Figure 18, Quadruple Word Program Flowchart and Pseudo Code, for the flowchart for using the Quadruple Word Program command.

Clear Status Register Command

The Clear Status Register command can be used to reset bits 1, 3, 4 and 5 in the Status Register to '0'. One bus write cycle is required to issue the Clear Status Register command.

The bits in the Status Register do not automatically return to '0' when a new Program or Erase command is issued. The error bits in the Status Register should be cleared before attempting a new Program or Erase command.

Program/Erase Suspend Command

The Program/Erase Suspend command is used to pause a Program or Erase operation. One bus write cycle is required to issue the Program/Erase command and pause the Program/Erase controller.

During Program/Erase Suspend the Command Interface will accept the Program/Erase Resume, Read Array, Read Status Register, Read Electronic Signature and Read CFI Query commands. Ad-

ditionally, if the suspend operation was Erase then the Program, Double Word Program and Quadruple Word Program commands will also be accepted. Only the blocks not being erased may be read or programmed correctly.

During a Program/Erase Suspend, the device can be placed in a pseudo-standby mode by taking Chip Enable to V_{IH} . Program/Erase is aborted if Reset turns to V_{IL} .

See Appendix C, Figure 19, Program Suspend & Resume Flowchart and Pseudo Code, and Figure 21, Erase Suspend & Resume Flowchart and Pseudo Code for flowcharts for using the Program/Erase Suspend command.

Program/Erase Resume Command

The Program/Erase Resume command can be used to restart the Program/Erase Controller after a Program/Erase Suspend operation has paused it. One Bus Write cycle is required to issue the command. Once the command is issued subse-

quent Bus Read operations read the Status Register.

See Appendix C, Figure 19, Program or Double Word Program Suspend & Resume Flowchart and Pseudo Code, and Figure 21, Erase Suspend & Resume Flowchart and Pseudo Code for flowcharts for using the Program/Erase Resume command.

Block Protection

Two parameter/lockable blocks (blocks #0 and #1) can be protected against Program or Erase operations. Unprotected blocks can be programmed or erased.

To protect the two lockable blocks set Write Protect to V_{IL} . When V_{PP} is below V_{PPLK} all blocks are protected. Any attempt to Program or Erase protected blocks will abort, the data in the block will not be changed and the Status Register outputs the error.

Table 6, Memory Blocks Protection Truth Table, defines the protection methods.

EEPW.com.cn 电子产品世界

Table 4. Commands

Commands	No. of Cycles	Bus Write Operations											
		1st Cycle			2nd Cycle			3rd Cycle					
		Bus Op.	Addr	Data	Bus Op.	Addr	Data	Bus Op.	Addr	Data			
Read Memory Array	Write	X	FFh	Read	RA	RD							
Read Status Register	Write	X	70h	Read	X	SRD							
Read Electronic Signature	Write	X	90h	Read	SA ⁽²⁾	IDh							
Read CFI Query	Write	X	98h	Read	QA	QD							
Erase	Write	X	20h	Write	BA	D0h							
Program	Write	X	40h or 10h	Write	PA	PD							
Double Word Program ⁽³⁾	Write	X	30h	Write	PA1	PD1	Write	PA2	PD2				
Quadruple Word Program ⁽⁴⁾	Write	X	56h ⁽⁶⁾	Write	PA1	PD1	Write	PA2	PD2	Write	PA3	PD3	Write
Clear Status Register	Write	X	50h										
Program/Erase Suspend	Write	X	B0h										
Program/Erase Resume	Write	X	D0h										

Note: 1. X = Don't Care, RA=Read Address, RD=Read Data, SRD=Status Register Data, ID=Identifier (Manufacture and Device Code), QA=Query Address, QD=Query Data, BA=Block Address, PA=Program Address, PD=Program Data, PRA=Protection Register Address, PRD=Protection Register Data.

2. A0=V_{IL} outputs Manufacturer code, A0=V_{IH} outputs Device code. Address A7-A1 must be V_{IL}.
3. Program Addresses 1 and 2 must be consecutive Addresses differing only for A0.
4. Program Addresses 1,2,3 and 4 must be consecutive Addresses differing only for A0 and A1.
5. 55h is reserved.
6. To be characterized.

Table 5. Read Electronic Signature

Code	Device	\bar{E}	\bar{G}	\bar{W}	A0	A1-A7	A8-A20	DQ0-DQ7	DQ8-DQ15
Manufacture. Code		V _{IL}	V _{IL}	V _{IH}	V _{IL}	V _{IL}	Don't Care	20h	00h
Device Code	M28W320EBT	V _{IL}	V _{IL}	V _{IH}	V _{IH}	V _{IL}	Don't Care	BCh	88h
	M28W320EBB	V _{IL}	V _{IL}	V _{IH}	V _{IH}	V _{IL}	Don't Care	BDh	88h

Note: $\bar{R}\bar{P} = V_{IH}$.

Table 6. Memory Blocks Protection Truth Table

$V_{PP}^{(1)}$	\overline{RP}	$\overline{WP}^{(1)}$	Lockable Blocks (blocks #0 and #1)	Other Blocks
X	V_{IL}	X	Protected	Protected
V_{IL}	V_{IH}	X	Protected	Protected
V_{DD} or $V_{PPH}^{(2)}$	V_{IH}	V_{IL}	Protected	Unprotected
V_{DD} or $V_{PPH}^{(2)}$	V_{IH}	V_{IH}	Unprotected	Unprotected

Note: 1. X = Don't Care

2. V_{PP} must also be greater than the Program Voltage Lock Out V_{PPLK} .

Table 7. Program, Erase Times and Program/Erase Endurance Cycles

Parameter	Test Conditions	M28W320EB			Unit
		Min	Typ	Max	
Word Program	$V_{PP} = V_{DD}$		10	200	μs
Double Word Program	$V_{PP} = 12V \pm 5\%$		10	200	μs
Quadruple Word Program	$V_{PP} = 12V \pm 5\%$		10	200	μs
Main Block Program	$V_{PP} = 12V \pm 5\%$		0.16/0.08 ⁽¹⁾	5	s
	$V_{PP} = V_{DD}$		0.32	5	s
Parameter Block Program	$V_{PP} = 12V \pm 5\%$		0.02/0.01 ⁽¹⁾	4	s
	$V_{PP} = V_{DD}$		0.04	4	s
Main Block Erase	$V_{PP} = 12V \pm 5\%$		1	10	s
	$V_{PP} = V_{DD}$		1	10	s
Parameter Block Erase	$V_{PP} = 12V \pm 5\%$		0.4	10	s
	$V_{PP} = V_{DD}$		0.4	10	s
Program/Erase Cycles (per Block)		100,000			cycles

Note: 1. Typical time to program a Main or Parameter Block using the Double Word Program and the Quadruple Word Program commands respectively.

STATUS REGISTER

The Status Register provides information on the current or previous Program or Erase operation. The various bits convey information and errors on the operation. To read the Status register the Read Status Register command can be issued, refer to the Read Status Register Command section. To output the contents, the Status Register is latched on the falling edge of the Chip Enable or Output Enable signals, and can be read until Chip Enable or Output Enable returns to V_{IH} . Either Chip Enable or Output Enable must be toggled to update the latched data.

Bus Read operations from any address always read the Status Register during Program and Erase operations.

The bits in the Status Register are summarized in Table 8, Status Register Bits. Refer to Table 8 in conjunction with the following text descriptions.

Program/Erase Controller Status (Bit 7). The Program/Erase Controller Status bit indicates whether the Program/Erase Controller is active or inactive. When the Program/Erase Controller Status bit is Low (set to '0'), the Program/Erase Controller is active; when the bit is High (set to '1'), the Program/Erase Controller is inactive, and the device is ready to process a new command.

The Program/Erase Controller Status is Low immediately after a Program/Erase Suspend command is issued until the Program/Erase Controller pauses. After the Program/Erase Controller pauses the bit is High.

During Program, Erase, operations the Program/Erase Controller Status bit can be polled to find the end of the operation. Other bits in the Status Register should not be tested until the Program/Erase Controller completes the operation and the bit is High.

After the Program/Erase Controller completes its operation the Erase Status, Program Status, V_{PP} Status and Block Protection Status bits should be tested for errors.

Erase Suspend Status (Bit 6). The Erase Suspend Status bit (set to '1') indicates that an Erase operation has been suspended or is going to be suspended.

The Erase Suspend Status should only be considered valid when the Program/Erase Controller Status bit is High (Program/Erase Controller inactive). Bit 7 is set within 30 μ s of the Program/Erase Suspend command being issued therefore the memory may still complete the operation rather than entering the Suspend mode.

When a Program/Erase Resume command is issued the Erase Suspend Status bit returns Low.

memory may still complete the operation rather

Erase Status (Bit 5). The Erase Status bit can be used to identify if the memory has failed to verify that the block has erased correctly. When the Erase Status bit is High (set to '1'), the Program/Erase Controller has applied the maximum number of pulses to the block and still failed to verify that the block has erased correctly. The Erase Status bit should be read once the Program/Erase Controller Status bit is High (Program/Erase Controller inactive).

Once set High, the Erase Status bit can only be reset Low by a Clear Status Register command or a hardware reset. If set High it should be reset before a new Program or Erase command is issued, otherwise the new command will appear to fail.

Program Status (Bit 4). The Program Status bit is used to identify a Program failure. When the Program Status bit is High (set to '1'), the Program/Erase Controller has applied the maximum number of pulses to the byte and still failed to verify that it has programmed correctly. The Program Status bit should be read once the Program/Erase Controller Status bit is High (Program/Erase Controller inactive).

Once set High, the Program Status bit can only be reset Low by a Clear Status Register command or a hardware reset. If set High it should be reset before a new command is issued, otherwise the new command will appear to fail.

V_{PP} Status (Bit 3). The V_{PP} Status bit can be used to identify an invalid voltage on the V_{PP} pin during Program and Erase operations. The V_{PP} pin is only sampled at the beginning of a Program or Erase operation. Indeterminate results can occur if V_{PP} becomes invalid during an operation.

When the V_{PP} Status bit is Low (set to '0'), the voltage on the V_{PP} pin was sampled at a valid voltage; when the V_{PP} Status bit is High (set to '1'), the V_{PP} pin has a voltage that is below the V_{PP} Lockout Voltage, V_{PPLK} , the memory is protected and Program and Erase operations cannot be performed.

Once set High, the V_{PP} Status bit can only be reset Low by a Clear Status Register command or a hardware reset. If set High it should be reset before a new Program or Erase command is issued, otherwise the new command will appear to fail.

Program Suspend Status (Bit 2). The Program Suspend Status bit (set to '1') indicates that a Program operation has been suspended or is going to be suspended.

The Program Suspend Status should only be considered valid when the Program/Erase Controller Status bit is High (Program/Erase Controller inactive). Bit 2 is set within 5 μ s of the Program/Erase Suspend command being issued therefore the than entering the Suspend mode.

When a Program/Erase Resume command is issued the Program Suspend Status bit returns Low.

Block Protection Status (Bit 1). The Block Protection Status bit can be used to identify if a Program or Erase operation has tried to modify the contents of a protected block.

When the Block Protection Status bit is High (set to '1'), a Program or Erase operation has been attempted on a protected block.

Once set High, the Block Protection Status bit can only be reset Low by a Clear Status Register command or a hardware reset. If set High it should be reset before a new command is issued, otherwise the new command will appear to fail.

Reserved (Bit 0). Bit 0 of the Status Register is reserved. Its value must be masked.

Note: Refer to Appendix C, Flowcharts and Pseudo Codes, for using the Status Register.

Table 8. Status Register Bits

Bit	Name	Logic Level	Definition
7	P/E.C. Status	'1'	Ready
		'0'	Busy
6	Erase Suspend Status	'1'	Suspended
		'0'	In progress or Completed
5	Erase Status	'1'	Erase Error
		'0'	Erase Success
4	Program Status	'1'	Program Error
		'0'	Program Success
3	V _{PP} Status	'1'	V _{PP} Invalid, Abort
		'0'	V _{PP} OK
2	Program Suspend Status	'1'	Suspended
		'0'	In Progress or Completed
1	Block Protection Status	'1'	Program/Erase on protected Block, Abort
		'0'	No operation to protected blocks
0	Reserved		

Note: Logic level '1' is High, '0' is Low.

MAXIMUM RATING

Stressing the device above the rating listed in the Absolute Maximum Ratings table may cause permanent damage to the device. Exposure to Absolute Maximum Rating conditions for extended periods may affect device reliability. These are stress ratings only and operation of the device at

these or any other conditions above those indicated in the Operating sections of this specification is not implied. Refer also to the STMicroelectronics SURE Program and other relevant quality documents.

Table 9. Absolute Maximum Ratings

Symbol	Parameter	Value		Unit
		Min	Max	
T _A	Ambient Operating Temperature ⁽¹⁾	-40	85	°C
T _{BIAS}	Temperature Under Bias	-40	125	°C
T _{STG}	Storage Temperature	-55	155	°C
V _{IO}	Input or Output Voltage	-0.6	V _{DDQ} +0.6	V
V _{DD} , V _{DDQ}	Supply Voltage	-0.6	4.1	V
V _{PP}	Program Voltage	-0.6	13	V

Note: 1. Depends on range.



DC AND AC PARAMETERS

This section summarizes the operating and measurement conditions, and the DC and AC characteristics of the device. The parameters in the DC and AC characteristics Tables that follow, are derived from tests performed under the Measure-

ment Conditions summarized in Table 10, Operating and AC Measurement Conditions. Designers should check that the operating conditions in their circuit match the measurement conditions when relying on the quoted parameters.

Table 10. Operating and AC Measurement Conditions

Parameter	M28W320EBT, M28W320EBB								Units
	70		85		90		100		
	Min	Max	Min	Max	Min	Max	Min	Max	
V _{DD} Supply Voltage	2.7	3.6	2.7	3.6	2.7	3.6	2.7	3.6	V
V _{DDQ} Supply Voltage (V _{DDQ} ≤ V _{DD})	2.7	3.6	2.7	3.6	2.7	3.6	1.65	3.6	V
Ambient Operating Temperature	-40	85	-40	85	-40	85	-40	85	°C
Load Capacitance (C _L)	50		50		50		50		pF
Input Rise and Fall Times		5		5		5		5	ns
Input Pulse Voltages	0 to V _{DDQ}		0 to V _{DDQ}		0 to V _{DDQ}		0 to V _{DDQ}		V
Input and Output Timing Ref. Voltages	V _{DDQ} /2		V _{DDQ} /2		V _{DDQ} /2		V _{DDQ} /2		V

Figure 6. AC Measurement I/O Waveform

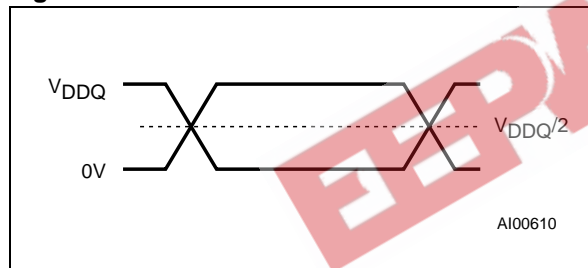

Figure 7. AC Measurement Load Circuit

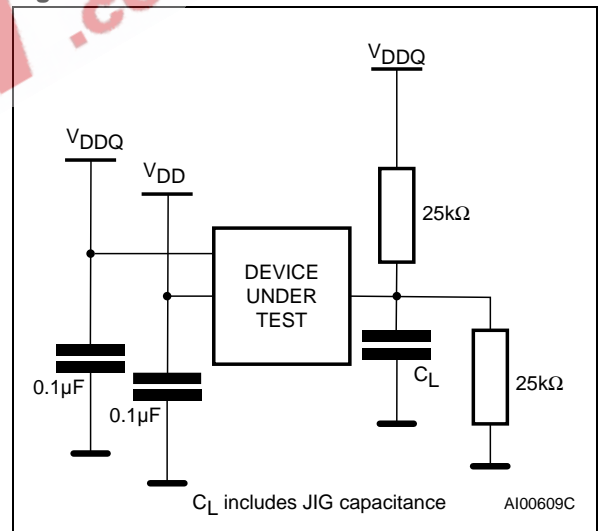

Table 11. Device Capacitance

Symbol	Parameter	Test Condition	Min	Max	Unit
C _{IN}	Input Capacitance	V _{IN} = 0V		6	pF
C _{OUT}	Output Capacitance	V _{OUT} = 0V		12	pF

Note: Sampled only, not 100% tested.

Table 12. DC Characteristics

Symbol	Parameter	Test Condition	Min	Typ	Max	Unit
I _{LI}	Input Leakage Current	0V ≤ V _{IN} ≤ V _{DDQ}			±1	μA
I _{LO}	Output Leakage Current	0V ≤ V _{OUT} ≤ V _{DDQ}			±10	μA
I _{DD}	Supply Current (Read)	$\bar{E} = V_{SS}, \bar{G} = V_{IH}, f = 5\text{MHz}$		9	18	mA
I _{DD1}	Supply Current (Stand-by or Automatic Stand-by)	$\bar{E} = V_{DDQ} \pm 0.2\text{V},$ $\bar{R}\bar{P} = V_{DDQ} \pm 0.2\text{V}$		15	50	μA
I _{DD2}	Supply Current (Reset)	$\bar{R}\bar{P} = V_{SS} \pm 0.2\text{V}$		15	50	μA
I _{DD3}	Supply Current (Program)	Program in progress V _{PP} = 12V ± 5%		5	10	mA
		Program in progress V _{PP} = V _{DD}		10	20	mA
I _{DD4}	Supply Current (Erase)	Erase in progress V _{PP} = 12V ± 5%		5	20	mA
		Erase in progress V _{PP} = V _{DD}		10	20	mA
I _{DD5}	Supply Current (Program/Erase Suspend)	$\bar{E} = V_{DDQ} \pm 0.2\text{V},$ Erase suspended		15	50	μA
I _{PP}	Program Current (Read or Stand-by)	V _{PP} > V _{DD}			400	μA
I _{PP1}	Program Current (Read or Stand-by)	V _{PP} ≤ V _{DD}		1	5	μA
I _{PP2}	Program Current (Reset)	$\bar{R}\bar{P} = V_{SS} \pm 0.2\text{V}$		1	5	μA
I _{PP3}	Program Current (Program)	Program in progress V _{PP} = 12V ± 5%		1	10	mA
		Program in progress V _{PP} = V _{DD}		1	5	μA
I _{PP4}	Program Current (Erase)	Erase in progress V _{PP} = 12V ± 5%		3	10	mA
		Erase in progress V _{PP} = V _{DD}		1	5	μA
V _{IL}	Input Low Voltage		-0.5		0.4	V
		V _{DDQ} ≥ 2.7V	-0.5		0.8	V
V _{IH}	Input High Voltage		V _{DDQ} - 0.4		V _{DDQ} + 0.4	V
		V _{DDQ} ≥ 2.7V	0.7 V _{DDQ}		V _{DDQ} + 0.4	V
V _{OL}	Output Low Voltage	I _{OL} = 100μA, V _{DD} = V _{DD} min, V _{DDQ} = V _{DDQ} min			0.1	V
V _{OH}	Output High Voltage	I _{OH} = -100μA, V _{DD} = V _{DD} min, V _{DDQ} = V _{DDQ} min	V _{DDQ} - 0.1			V
V _{PP1}	Program Voltage (Program or Erase operations)		1.65		3.6	V
V _{PPH}	Program Voltage (Program or Erase operations)		11.4		12.6	V
V _{PPLK}	Program Voltage (Program and Erase lock-out)				1	V
V _{LKO}	V _{DD} Supply Voltage (Program and Erase lock-out)				2	V

Figure 8. Read AC Waveforms

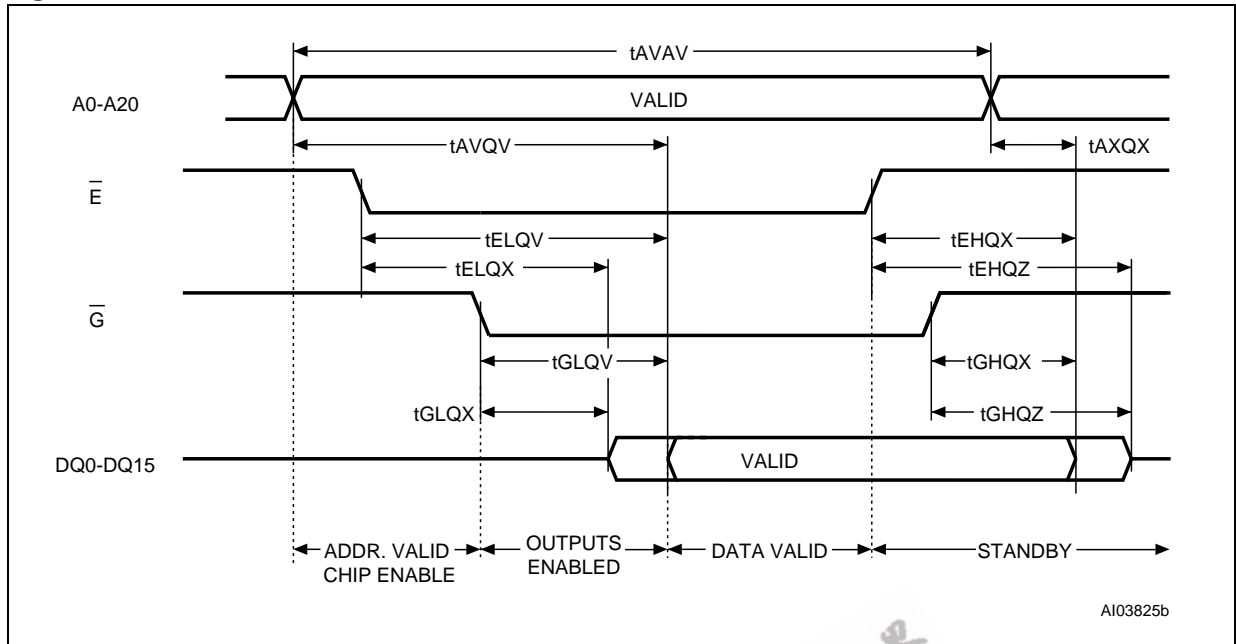

Table 13. Read AC Characteristics

Symbol	Alt	Parameter		M28W320EB				Unit
				70	85	90	10	
t_{AVAV}	t_{RC}	Address Valid to Next Address Valid	Min	70	85	90	100	ns
t_{AVQV}	t_{ACC}	Address Valid to Output Valid	Max	70	85	90	100	ns
$t_{AXQX}^{(1)}$	t_{OH}	Address Transition to Output Transition	Min	0	0	0	0	ns
$t_{EHQX}^{(1)}$	t_{OH}	Chip Enable High to Output Transition	Min	0	0	0	0	ns
$t_{EHQZ}^{(1)}$	t_{HZ}	Chip Enable High to Output Hi-Z	Max	20	20	25	30	ns
$t_{ELQV}^{(2)}$	t_{CE}	Chip Enable Low to Output Valid	Max	70	85	90	100	ns
$t_{ELQX}^{(1)}$	t_{LZ}	Chip Enable Low to Output Transition	Min	0	0	0	0	ns
$t_{GHQX}^{(1)}$	t_{OH}	Output Enable High to Output Transition	Min	0	0	0	0	ns
$t_{GHQZ}^{(1)}$	t_{DF}	Output Enable High to Output Hi-Z	Max	20	20	25	30	ns
$t_{GLQV}^{(2)}$	t_{OE}	Output Enable Low to Output Valid	Max	20	20	30	35	ns
$t_{GLQX}^{(1)}$	t_{OLZ}	Output Enable Low to Output Transition	Min	0	0	0	0	ns

Note: 1. Sampled only, not 100% tested.

2. \bar{G} may be delayed by up to $t_{ELQV} - t_{GLQV}$ after the falling edge of \bar{E} without increasing t_{ELQV} .

Table 14. Write AC Characteristics, Write Enable Controlled

Symbol	Alt	Parameter		M28W320EB				Unit
				70	85	90	10	
t _{AVAV}	t _{WC}	Write Cycle Time	Min	70	85	90	100	ns
t _{AVWH}	t _{AS}	Address Valid to Write Enable High	Min	45	45	50	50	ns
t _{DVWH}	t _{DS}	Data Valid to Write Enable High	Min	45	45	50	50	ns
t _{ELWL}	t _{CS}	Chip Enable Low to Write Enable Low	Min	0	0	0	0	ns
t _{ELQV}		Chip Enable Low to Output Valid	Min	70	85	90	100	ns
t _{QVVP L} ^(1,2)		Output Valid to V _{PP} Low	Min	0	0	0	0	ns
t _{QVWPL}		Output Valid to Write Protect Low	Min	0	0	0	0	ns
t _{VPHWH} ⁽¹⁾	t _{VPS}	V _{PP} High to Write Enable High	Min	200	200	200	200	ns
t _{WHAX}	t _{AH}	Write Enable High to Address Transition	Min	0	0	0	0	ns
t _{WHDX}	t _{DH}	Write Enable High to Data Transition	Min	0	0	0	0	ns
t _{WHEH}	t _{CH}	Write Enable High to Chip Enable High	Min	0	0	0	0	ns
t _{WHEL}		Write Enable High to Chip Enable Low	Min	25	25	30	30	ns
t _{WHGL}		Write Enable High to Output Enable Low	Min	20	20	30	30	ns
t _{WHWL}	t _{WPH}	Write Enable High to Write Enable Low	Min	25	25	30	30	ns
t _{WLWH}	t _{WP}	Write Enable Low to Write Enable High	Min	45	45	50	50	ns
t _{WPHWH}		Write Protect High to Write Enable High	Min	45	45	50	50	ns

Note: 1. Sampled only, not 100% tested.

2. Applicable if V_{PP} is seen as a logic input (V_{PP} < 3.6V).

Figure 10. Write AC Waveforms, Chip Enable Controlled

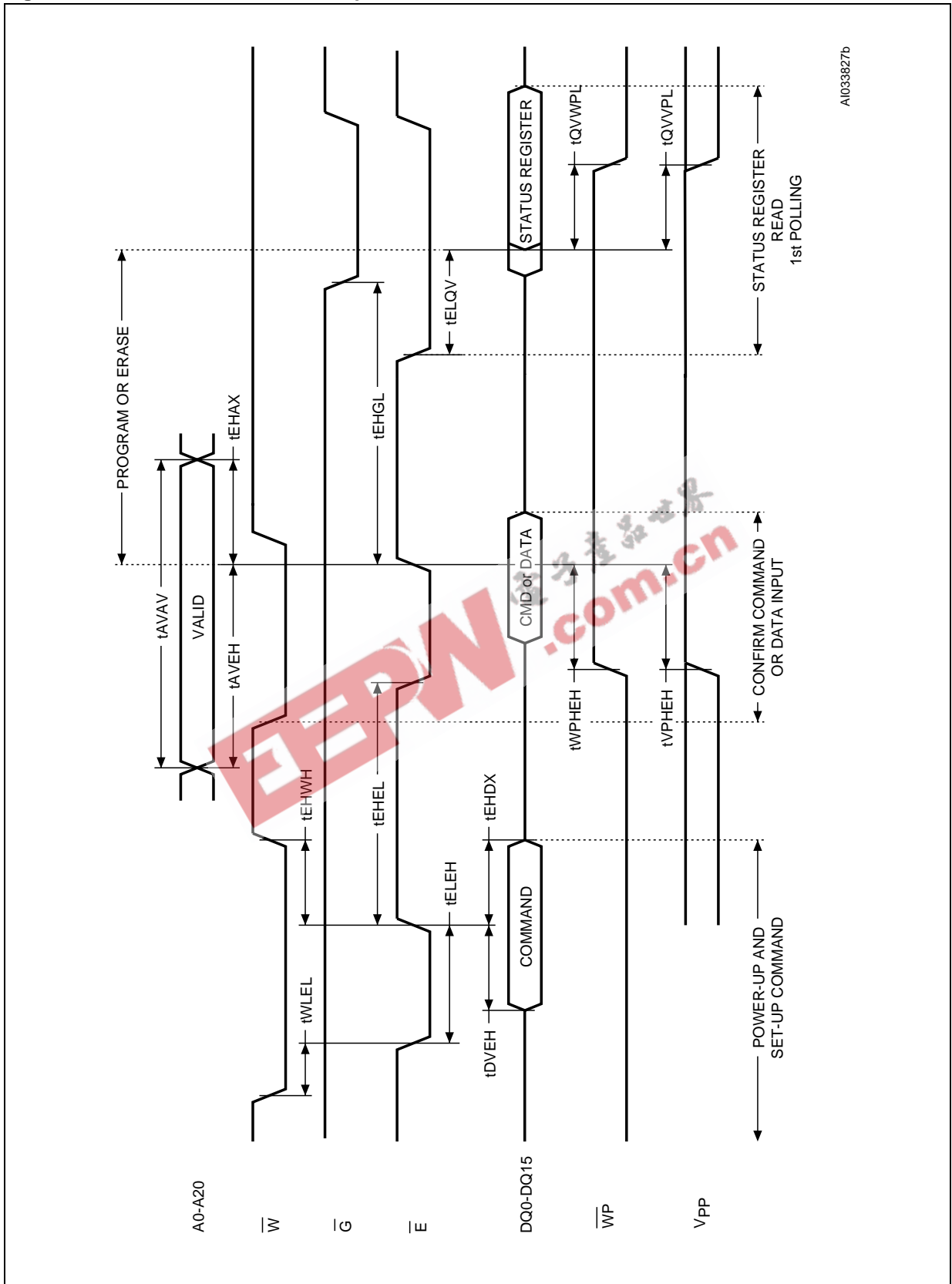

A1033827b

Table 15. Write AC Characteristics, Chip Enable Controlled

Symbol	Alt	Parameter		M28W320EB				Unit
				70	85	90	10	
t _{AVAV}	t _{WC}	Write Cycle Time	Min	70	85	90	100	ns
t _{AVEH}	t _{AS}	Address Valid to Chip Enable High	Min	45	45	50	50	ns
t _{DVEH}	t _{DS}	Data Valid to Chip Enable High	Min	45	45	50	50	ns
t _{EHAX}	t _{AH}	Chip Enable High to Address Transition	Min	0	0	0	0	ns
t _{EHDX}	t _{DH}	Chip Enable High to Data Transition	Min	0	0	0	0	ns
t _{EHHL}	t _{CPH}	Chip Enable High to Chip Enable Low	Min	25	25	30	30	ns
t _{EHGL}		Chip Enable High to Output Enable Low	Min	25	25	30	30	ns
t _{EHWH}	t _{WH}	Chip Enable High to Write Enable High	Min	0	0	0	0	ns
t _{ELEH}	t _{CP}	Chip Enable Low to Chip Enable High	Min	45	45	50	50	ns
t _{ELQV}		Chip Enable Low to Output Valid	Min	70	85	90	100	ns
t _{QVPL} ^(1,2)		Output Valid to V _{PP} Low	Min	0	0	0	0	ns
t _{QVWL}		Data Valid to Write Protect Low	Min	0	0	0	0	ns
t _{VPHEH} ⁽¹⁾	t _{VPS}	V _{PP} High to Chip Enable High	Min	200	200	200	200	ns
t _{WLEL}	t _{CS}	Write Enable Low to Chip Enable Low	Min	0	0	0	0	ns
t _{WPHEH}		Write Protect High to Chip Enable High	Min	45	45	50	50	ns

Note: 1. Sampled only, not 100% tested.

2. Applicable if V_{PP} is seen as a logic input (V_{PP} < 3.6V).

Figure 11. Power-Up and Reset AC Waveforms

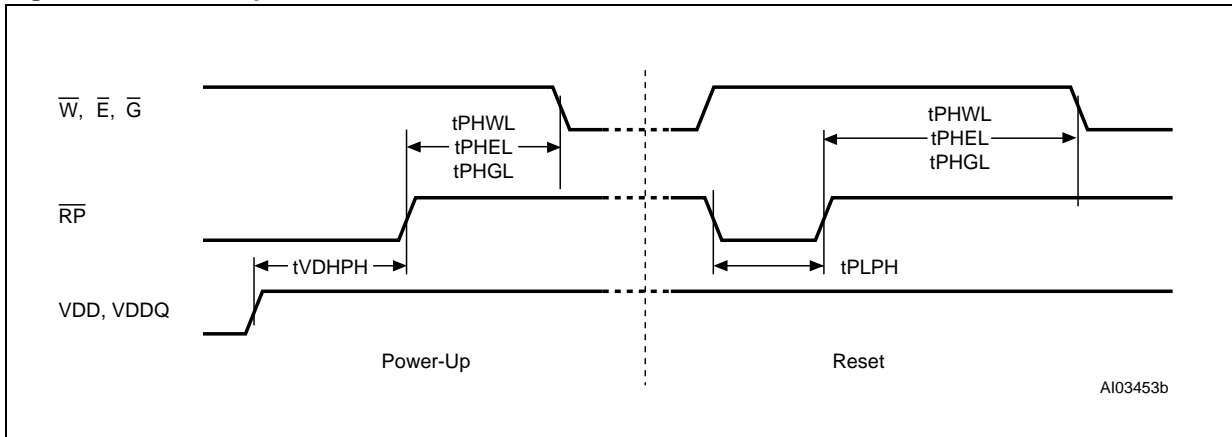

Table 16. Power-Up and Reset AC Characteristics

Symbol	Parameter	Test Condition		M28W320EB				Unit
				70	85	90	10	
tPHWL tPEHL tPHGL	Reset High to Write Enable Low, Chip Enable Low, Output Enable Low	During Program and Erase	Min	50	50	50	50	μs
			others	Min	30	30	30	30
tPLPH ^(1,2)	Reset Low to Reset High		Min	100	100	100	100	ns
tVDHPH ⁽³⁾	Supply Voltages High to Reset High		Min	50	50	50	50	μs

Note: 1. The device Reset is possible but not guaranteed if tPLPH < 100ns.
 2. Sampled only, not 100% tested.
 3. It is important to assert RP in order to allow proper CPU initialization during power up or reset.

PACKAGE MECHANICAL

Figure 12. TSOP48 - 48 lead Plastic Thin Small Outline, 12 x 20mm, Package Outline

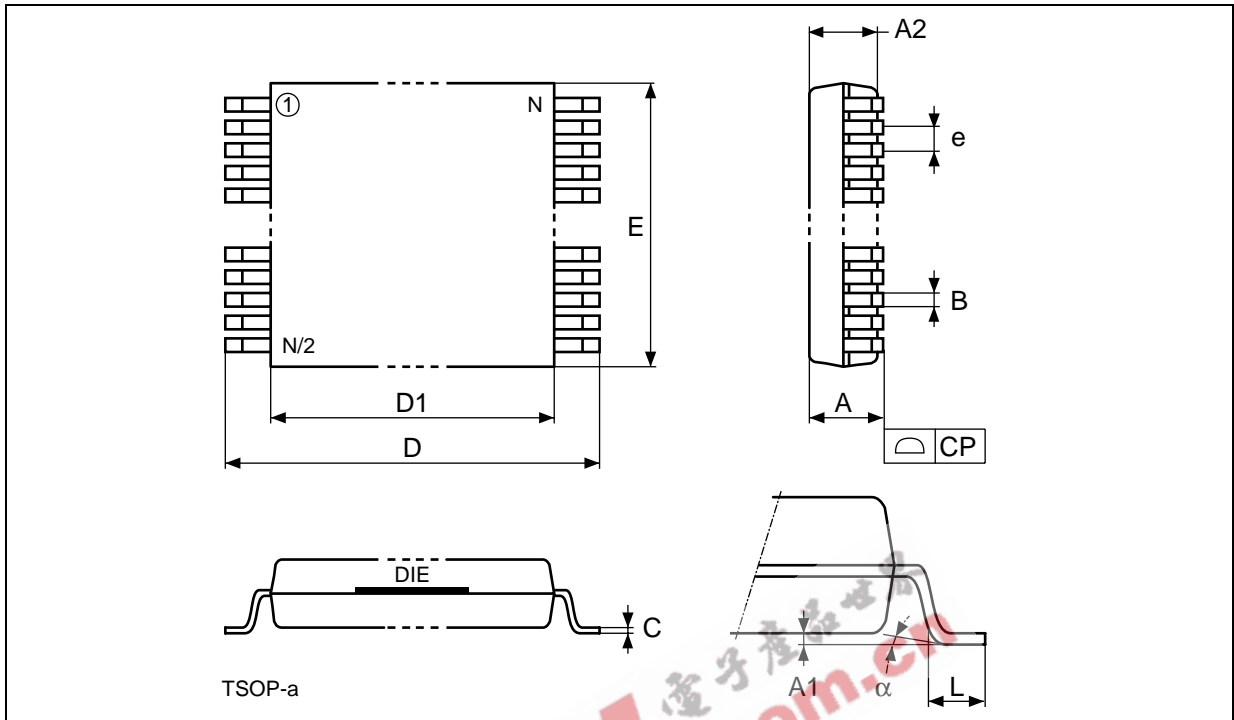

Note: Drawing is not to scale.

Table 17. TSOP48 - 48 lead Plastic Thin Small Outline, 12 x 20mm, Package Mechanical Data

Symbol	mm			inches		
	Typ	Min	Max	Typ	Min	Max
A			1.20			0.0472
A1		0.05	0.15		0.0020	0.0059
A2		0.95	1.05		0.0374	0.0413
B		0.17	0.27		0.0067	0.0106
C		0.10	0.21		0.0039	0.0083
D		19.80	20.20		0.7795	0.7953
D1		18.30	18.50		0.7205	0.7283
E		11.90	12.10		0.4685	0.4764
e	0.50	-	-	0.0197	-	-
L		0.50	0.70		0.0197	0.0279
alpha		0°	5°		0°	5°
N	48			48		
CP			0.10			0.0039

M28W320EBT, M28W320EBB

Figure 13. TFBGA47 6.39x6.37mm - 8x6 ball array, 0.75mm pitch, Bottom View Package Outline

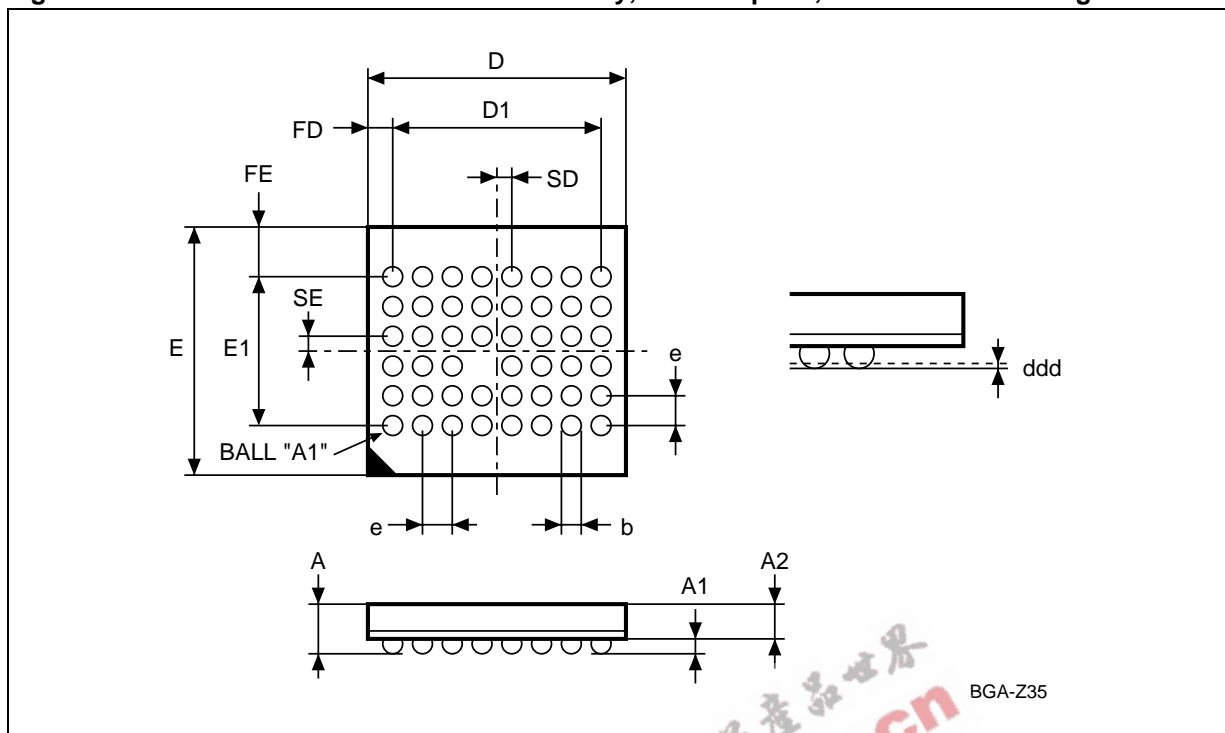

Note: Drawing is not to scale.

Table 18. TFBGA47 6.39x6.37mm - 8x6 ball array, 0.75mm pitch, Package Mechanical Data

Symbol	millimeters			inches		
	Typ	Min	Max	Typ	Min	Max
A			1.200			0.0472
A1		0.200			0.0079	
A2			1.000			0.0394
b	0.400	0.350	0.450	0.0157	0.0138	0.0177
D	6.390	6.290	6.490	0.2516	0.2476	0.2555
D1	5.250	–	–	0.2067	–	–
ddd			0.100			0.0039
E	6.370	6.270	6.470	0.2508	0.2469	0.2547
E1	3.750	–	–	0.1476	–	–
e	0.750	–	–	0.0295	–	–
FD	0.570	–	–	0.0224	–	–
FE	1.310	–	–	0.0516	–	–
SD	0.375	–	–	0.0148	–	–
SE	0.375	–	–	0.0148	–	–

Figure 14. TFBGA47 Daisy Chain - Package Connections (Top view through package)

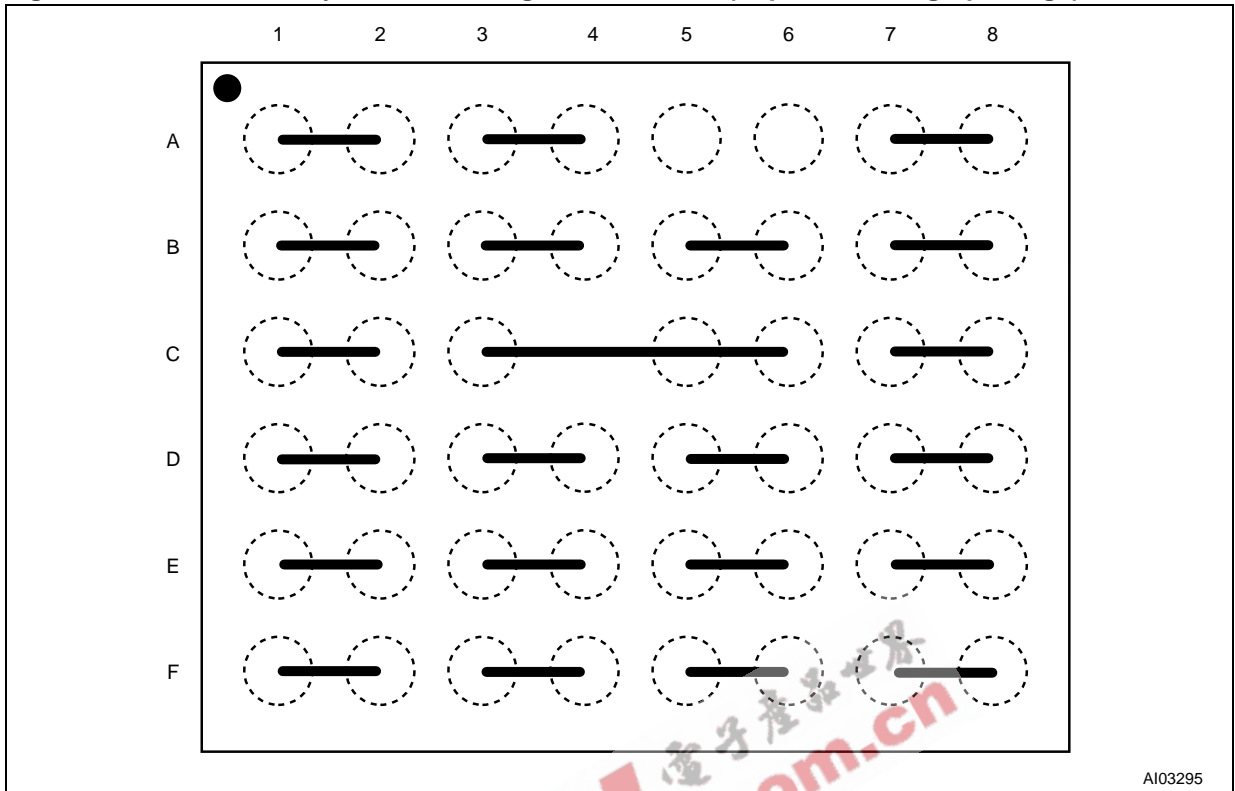
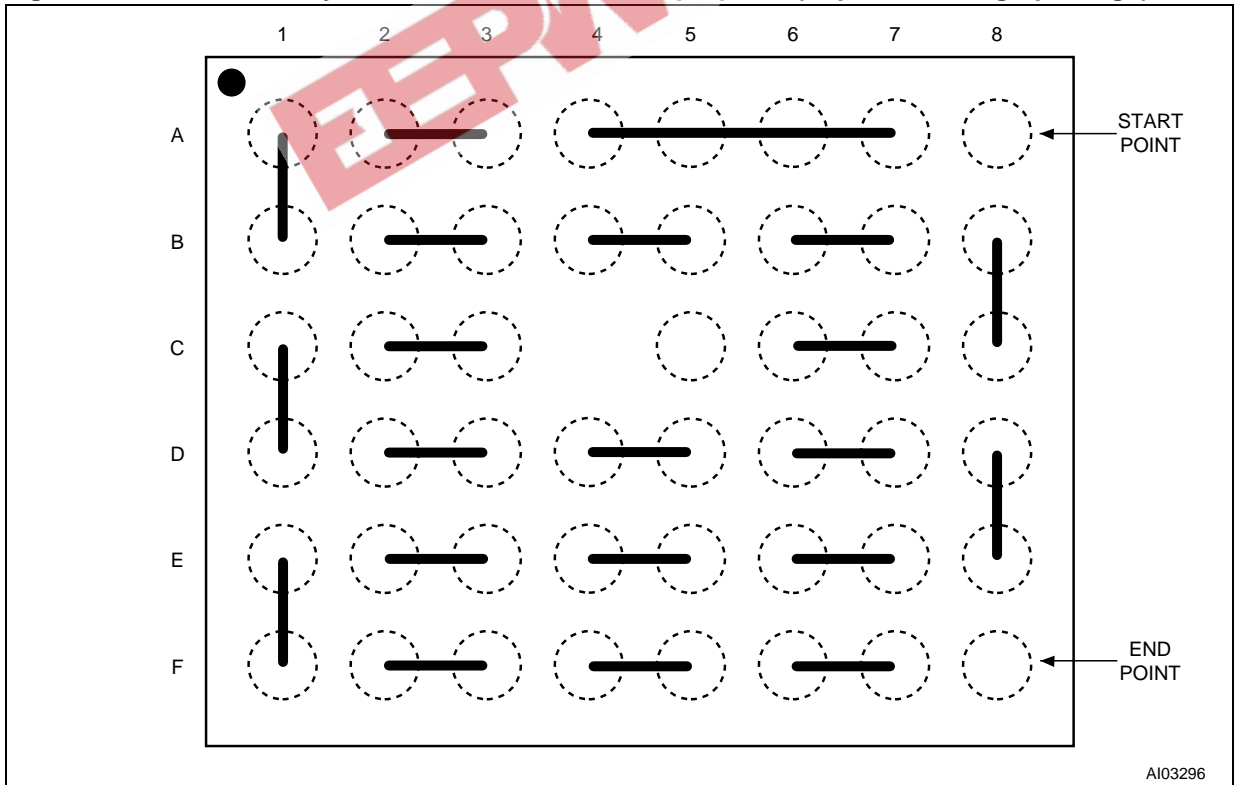

Figure 15. TFBGA47 Daisy Chain - PCB Connections proposal (Top view through package)



M28W320EBT, M28W320EBB

PART NUMBERING

Table 19. Ordering Information Scheme

Example:	M28W320EBT	90	N	6	T
Device Type	M28				
Operating Voltage	W = V _{DD} = 2.7V to 3.6V; V _{DDQ} = 1.65V to 3.6V				
Device Function	320EB = 32 Mbit (x16), Boot Block				
Array Matrix	T = Top Boot B = Bottom Boot				
Speed	70 = 70 ns 85 = 85 ns 90 = 90 ns 10 = 100 ns				
Package	N = TSOP48: 12 x 20 mm ZB = TFBGA47: 6.39 x 6.37mm, 0.75 mm pitch				
Temperature Range	1 = 0 to 70 °C 6 = -40 to 85 °C				
Option	T = Tape & Reel Packing				

Table 20. Daisy Chain Ordering Scheme

Example:	M28W320EB	-ZB	T
Device Type	M28W320EB		
Daisy Chain	-ZB = TFBGA47: 6.39 x 6.37mm, 0.75 mm pitch		
Option	T = Tape & Reel Packing		

Note: Devices are shipped from the factory with the memory content bits erased to '1'. For a list of available options (Speed, Package, etc...) or for further information on any aspect of this device, please contact the ST Sales Office nearest to you.

APPENDIX A. BLOCK ADDRESS TABLES

Table 21. Top Boot Block Addresses, M28W320EBT

#	Size (KWord)	Address Range
0	4	1FF000-1FFFFF
1	4	1FE000-1FEFFF
2	4	1FD000-1FDFFF
3	4	1FC000-1FCFFF
4	4	1FB000-1FBFFF
5	4	1FA000-1FAFFF
6	4	1F9000-1F9FFF
7	4	1F8000-1F8FFF
8	32	1F0000-1F7FFF
9	32	1E8000-1EFFFF
10	32	1E0000-1E7FFF
11	32	1D8000-1DFFFF
12	32	1D0000-1D7FFF
13	32	1C8000-1CFFFF
14	32	1C0000-1C7FFF
15	32	1B8000-1BFFFF
16	32	1B0000-1B7FFF
17	32	1A8000-1AFFFF
18	32	1A0000-1A7FFF
19	32	198000-19FFFF
20	32	190000-197FFF
21	32	188000-18FFFF
22	32	180000-187FFF
23	32	178000-17FFFF
24	32	170000-177FFF
25	32	168000-16FFFF
26	32	160000-167FFF
27	32	158000-15FFFF
28	32	150000-157FFF
29	32	148000-14FFFF
30	32	140000-147FFF
31	32	138000-13FFFF
32	32	130000-137FFF
33	32	128000-12FFFF

34	32	120000-127FFF
35	32	118000-11FFFF
36	32	110000-117FFF
37	32	108000-10FFFF
38	32	100000-107FFF
39	32	0F8000-0FFFFF
40	32	0F00000-F7FFF
41	32	0E8000-0EFFFF
42	32	0E0000-0E7FFF
43	32	0D8000-0DFFFF
44	32	0D0000-0D7FFF
45	32	0C8000-0CFFFF
46	32	0C0000-0C7FFF
47	32	0B8000-0BFFFF
48	32	0B0000-0B7FFF
49	32	0A8000-0AFFFF
50	32	0A0000-0A7FFF
51	32	098000-09FFFF
52	32	090000-097FFF
53	32	088000-08FFFF
54	32	080000-087FFF
55	32	078000-07FFFF
56	32	070000-077FFF
57	32	068000-06FFFF
58	32	060000-067FFF
59	32	058000-05FFFF
60	32	050000-057FFF
61	32	048000-04FFFF
62	32	040000-047FFF
63	32	038000-03FFFF
64	32	030000-037FFF
65	32	028000-02FFFF
66	32	020000-027FFF
67	32	018000-01FFFF
68	32	010000-017FFF
69	32	008000-00FFFF
70	32	000000-007FFF

M28W320EBT, M28W320EBB

Table 22. Bottom Boot Block Addresses, M28W320EBB

#	Size (KWord)	Address Range
70	32	1F8000-1FFFFFF
69	32	1F0000-1F7FFF
68	32	1E8000-1EFFFF
67	32	1E0000-1E7FFF
66	32	1D8000-1DFFFF
65	32	1D0000-1D7FFF
64	32	1C8000-1CFFFF
63	32	1C0000-1C7FFF
62	32	1B8000-1BFFFF
61	32	1B0000-1B7FFF
60	32	1A8000-1AFFFF
59	32	1A0000-1A7FFF
58	32	198000-19FFFF
57	32	190000-197FFF
56	32	188000-18FFFF
55	32	180000-187FFF
54	32	178000-17FFFF
53	32	170000-177FFF
52	32	168000-16FFFF
51	32	160000-167FFF
50	32	158000-15FFFF
49	32	150000-157FFF
48	32	148000-14FFFF
47	32	140000-147FFF
46	32	138000-13FFFF
45	32	130000-137FFF
44	32	128000-12FFFF
43	32	120000-127FFF
42	32	118000-11FFFF
41	32	110000-117FFF
40	32	108000-10FFFF
39	32	100000-107FFF
38	32	0F8000-0FFFFFF
37	32	0F0000-0F7FFF

36	32	0E8000-0EFFFF
35	32	0E0000-0E7FFF
34	32	0D8000-0DFFFF
33	32	0D0000-0D7FFF
32	32	0C8000-0CFFFF
31	32	0C0000-0C7FFF
30	32	0B8000-0BFFFF
29	32	0B0000-0B7FFF
28	32	0A8000-0AFFFF
27	32	0A0000-0A7FFF
26	32	098000-09FFFF
25	32	090000-097FFF
24	32	088000-08FFFF
23	32	080000-087FFF
22	32	078000-07FFFF
21	32	070000-077FFF
20	32	068000-06FFFF
19	32	060000-067FFF
18	32	058000-05FFFF
17	32	050000-057FFF
16	32	048000-04FFFF
15	32	040000-047FFF
14	32	038000-03FFFF
13	32	030000-037FFF
12	32	028000-02FFFF
11	32	020000-027FFF
10	32	018000-01FFFF
9	32	010000-017FFF
8	32	008000-00FFFF
7	4	007000-007FFF
6	4	006000-006FFF
5	4	005000-005FFF
4	4	004000-004FFF
3	4	003000-003FFF
2	4	002000-002FFF
1	4	001000-001FFF
0	4	000000-000FFF

APPENDIX B. COMMON FLASH INTERFACE (CFI)

The Common Flash Interface is a JEDEC approved, standardized data structure that can be read from the Flash memory device. It allows a system software to query the device to determine various electrical and timing parameters, density information and functions supported by the memory. The system can interface easily with the device, enabling the software to upgrade itself when necessary.

When the CFI Query Command (RCFI) is issued the device enters CFI Query mode and the data

structure is read from the memory. Tables 23, 24, 25, 26, 27 and 28 show the addresses used to retrieve the data.

The CFI data structure also contains a security area where a 64 bit unique security number is written (see Table 28, Security Code area). This area can be accessed only in Read mode by the final user. It is impossible to change the security number after it has been written by ST. Issue a Read command to return to Read mode.

Table 23. Query Structure Overview

Offset	Sub-section Name	Description
00h	Reserved	Reserved for algorithm-specific information
10h	CFI Query Identification String	Command set ID and algorithm data offset
1Bh	System Interface Information	Device timing & voltage information
27h	Device Geometry Definition	Flash device layout
P	Primary Algorithm-specific Extended Query table	Additional information specific to the Primary Algorithm (optional)
A	Alternate Algorithm-specific Extended Query table	Additional information specific to the Alternate Algorithm (optional)

Note: Query data are always presented on the lowest order data outputs.

Table 24. CFI Query Identification String

Offset	Data	Description	Value
00h	0020h	Manufacturer Code	ST
01h	88BCh 88BDh	Device Code	Top Bottom
02h-0Fh	reserved	Reserved	
10h	0051h	Query Unique ASCII String "QRY"	"Q"
11h	0052h	Query Unique ASCII String "QRY"	"R"
12h	0059h	Query Unique ASCII String "QRY"	"Y"
13h 14h	0003h 0000h	Primary Algorithm Command Set and Control Interface ID code 16 bit ID code defining a specific algorithm	Intel Compatible
15h 16h	offset = P = 0035h 0000h	Address for Primary Algorithm extended Query table	P=35h
17h 18h	0000h 0000h	Alternate Vendor Command Set and Control Interface ID Code second vendor - specified algorithm supported (note: 0000h means none exists)	NA
19h 1Ah	value = A = 0000h 0000h	Address for Alternate Algorithm extended Query table note: 0000h means none exists	NA

Note: Query data are always presented on the lowest order data outputs (DQ7-DQ0) only. DQ8-DQ15 are '0'.

Table 25. CFI Query System Interface Information

Offset	Data	Description	Value
1Bh	0027h	V _{DD} Logic Supply Minimum Program/Erase or Write voltage bit 7 to 4 BCD value in volts bit 3 to 0 BCD value in 100 mV	2.7V
1Ch	0036h	V _{DD} Logic Supply Maximum Program/Erase or Write voltage bit 7 to 4 BCD value in volts bit 3 to 0 BCD value in 100 mV	3.6V
1Dh	00B4h	V _{PP} [Programming] Supply Minimum Program/Erase voltage bit 7 to 4 HEX value in volts bit 3 to 0 BCD value in 100 mV	11.4V
1Eh	00C6h	V _{PP} [Programming] Supply Maximum Program/Erase voltage bit 7 to 4 HEX value in volts bit 3 to 0 BCD value in 100 mV	12.6V
1Fh	0004h	Typical timeout per single word program = 2 ⁿ μs	16μs
20h	0004h	Typical timeout for Double/ Quadruple Word Program = 2 ⁿ μs	16μs
21h	000Ah	Typical timeout per individual block erase = 2 ⁿ ms	1 s
22h	0000h	Typical timeout for full chip erase = 2 ⁿ ms	NA
23h	0005h	Maximum timeout for word program = 2 ⁿ times typical	512μs
24h	0005h	Maximum timeout for Double/ Quadruple Word Program = 2 ⁿ times typical	512μs
25h	0003h	Maximum timeout per individual block erase = 2 ⁿ times typical	8 s
26h	0000h	Maximum timeout for chip erase = 2 ⁿ times typical	NA

Table 26. Device Geometry Definition

Offset Word Mode	Data	Description	Value
27h	0016h	Device Size = 2^n in number of bytes	4MByte
28h 29h	0001h 0000h	Flash Device Interface Code description	x16 Async
2Ah 2Bh	0003h 0000h	Maximum number of bytes in multi-byte program or page = 2^n	8
2Ch	0002h	Number of Erase Block Regions within the device. It specifies the number of regions within the device containing contiguous Erase Blocks of the same size.	2
M28W320EBT	2Dh 2Eh	Region 1 Information Number of identical-size erase block = 003Eh+1	63
	2Fh 30h	Region 1 Information Block size in Region 1 = 0100h * 256 byte	64KByte
	31h 32h	Region 2 Information Number of identical-size erase block = 0007h+1	8
	33h 34h	Region 2 Information Block size in Region 2 = 0020h * 256 byte	8KByte
M28W320EBB	2Dh 2Eh	Region 1 Information Number of identical-size erase block = 0007h+1	8
	2Fh 30h	Region 1 Information Block size in Region 1 = 0020h * 256 byte	8KByte
	31h 32h	Region 2 Information Number of identical-size erase block = 003Eh+1	63
	33h 34h	Region 2 Information Block size in Region 2 = 0100h * 256 byte	64KByte

Table 27. Primary Algorithm-Specific Extended Query Table

Offset P = 35h (1)	Data	Description	Value
(P+0)h = 35h	0050h	Primary Algorithm extended Query table unique ASCII string "PRI"	"P"
(P+1)h = 36h	0052h		"R"
(P+2)h = 37h	0049h		"I"
(P+3)h = 38h	0031h	Major version number, ASCII	"1"
(P+4)h = 39h	0030h	Minor version number, ASCII	"0"
(P+5)h = 3Ah	0006h	Extended Query table contents for Primary Algorithm. Address (P+5)h contains less significant byte. bit 0 Chip Erase supported (1 = Yes, 0 = No) bit 1 Erase Suspend supported (1 = Yes, 0 = No) bit 2 Program Suspend (1 = Yes, 0 = No) bit 3 Lock/Unlock supported (1 = Yes, 0 = No) bit 4 Queued Erase supported (1 = Yes, 0 = No) bit 31 to 5 Reserved; undefined bits are '0'	No
(P+6)h = 3Bh	0000h		Yes
(P+7)h = 3Ch	0000h		Yes
(P+8)h = 3Dh	0000h		No
			No
(P+9)h = 3Eh	0001h		Supported Functions after Suspend Read Array, Read Status Register and CFI Query are always supported during Erase or Program operation bit 0 Program supported after Erase Suspend (1 = Yes, 0 = No) bit 7 to 1 Reserved; undefined bits are '0'
(P+A)h = 3Fh	0000h	Block Lock Status Defines which bits in the Block Status Register section of the Query are implemented. bit 0 Block Lock Status Register Lock/Unlock bit active (1 = Yes, 0 = No) bit 1 Block Lock Status Register Lock-Down bit active (1 = Yes, 0 = No) bit 15 to 2 Reserved for future use; undefined bits are '0'	NA
(P+B)h = 40h	0000h		
(P+C)h = 41h	0030h	V _{DD} Logic Supply Optimum Program/Erase voltage (highest performance) bit 7 to 4 HEX value in volts bit 3 to 0 BCD value in 100 mV	3V
(P+D)h = 42h	00C0h	V _{PP} Supply Optimum Program/Erase voltage bit 7 to 4 HEX value in volts bit 3 to 0 BCD value in 100 mV	12V
(P+E)h	0000h	Reserved	

Note: 1. See Table 24, offset 15h for P pointer definition.

Table 28. Security Code Area

Offset	Data	Description
81h	XXXX	64 bits unique device number.
82h	XXXX	
83h	XXXX	
84h	XXXX	

APPENDIX C. FLOWCHARTS AND PSEUDO CODES

Figure 16. Program Flowchart and Pseudo Code

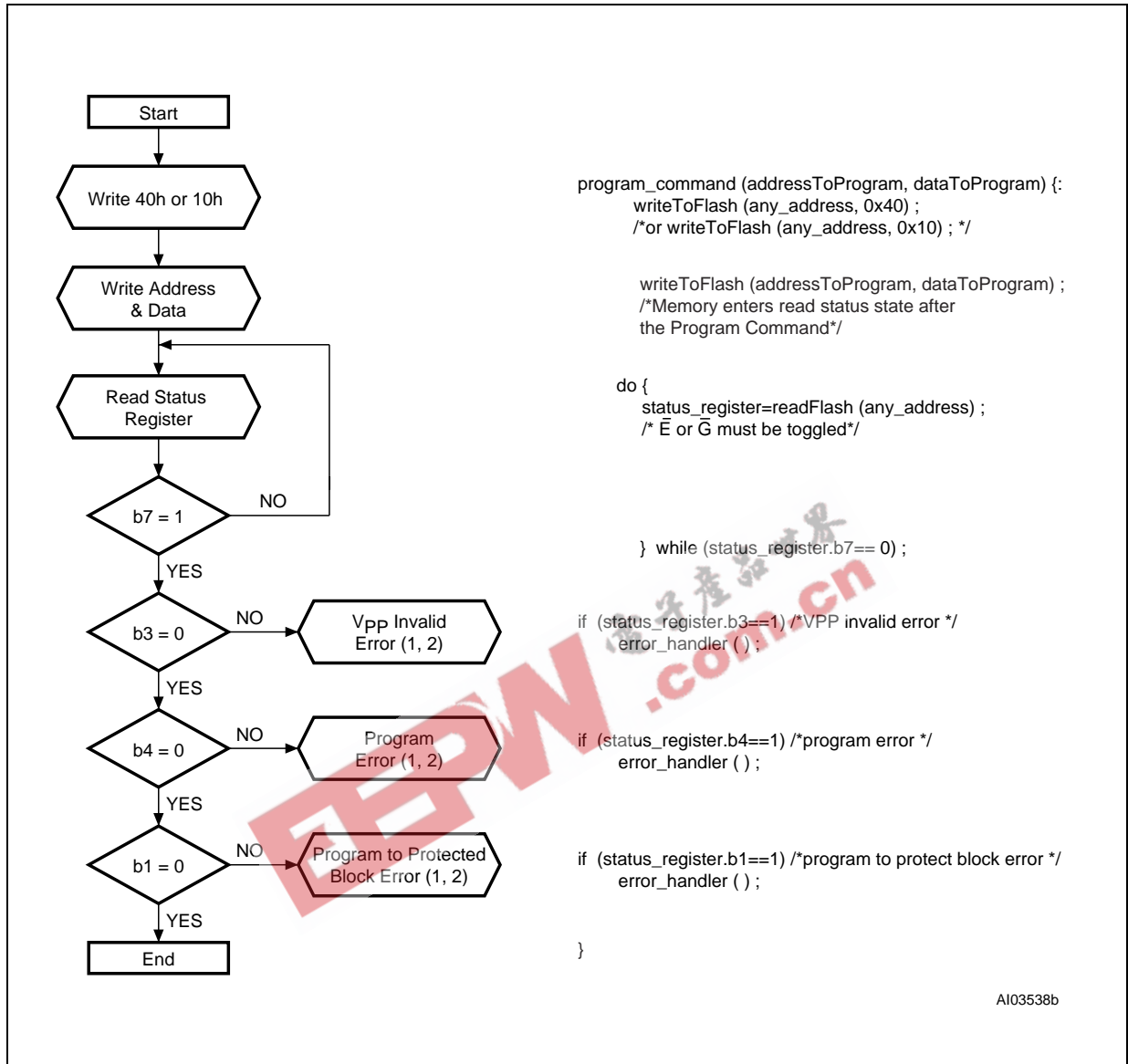

- Note: 1. Status check of b1 (Protected Block), b3 (Vpp Invalid) and b4 (Program Error) can be made after each program operation or after a sequence.
 2. If an error is found, the Status Register must be cleared before further Program/Erase Controller operations.

Figure 17. Double Word Program Flowchart and Pseudo Code

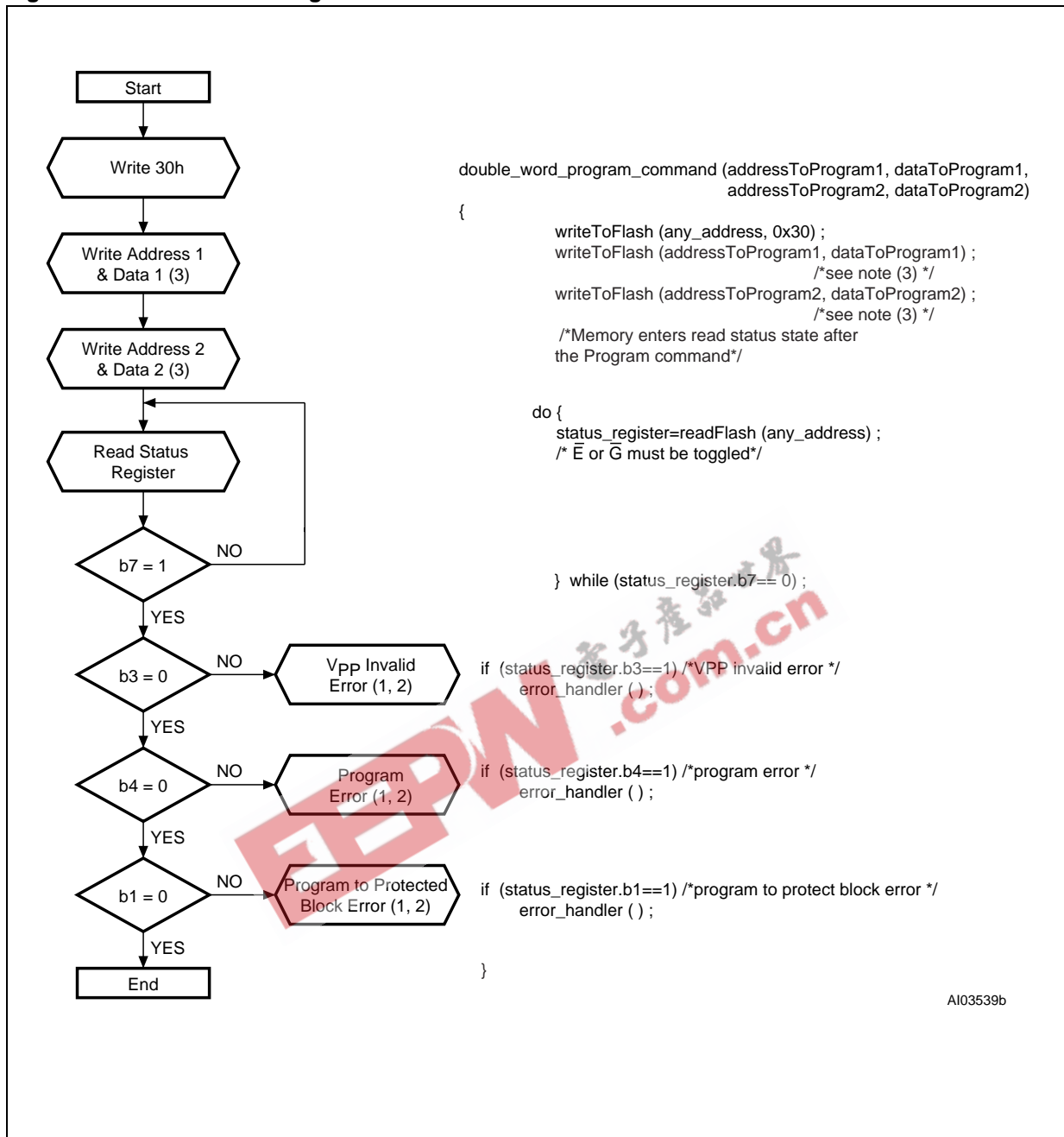

- Note: 1. Status check of b1 (Protected Block), b3 (VPP Invalid) and b4 (Program Error) can be made after each program operation or after a sequence.
 2. If an error is found, the Status Register must be cleared before further Program/Erase operations.
 3. Address 1 and Address 2 must be consecutive addresses differing only for bit A0.

Figure 18. Quadruple Word Program Flowchart and Pseudo Code

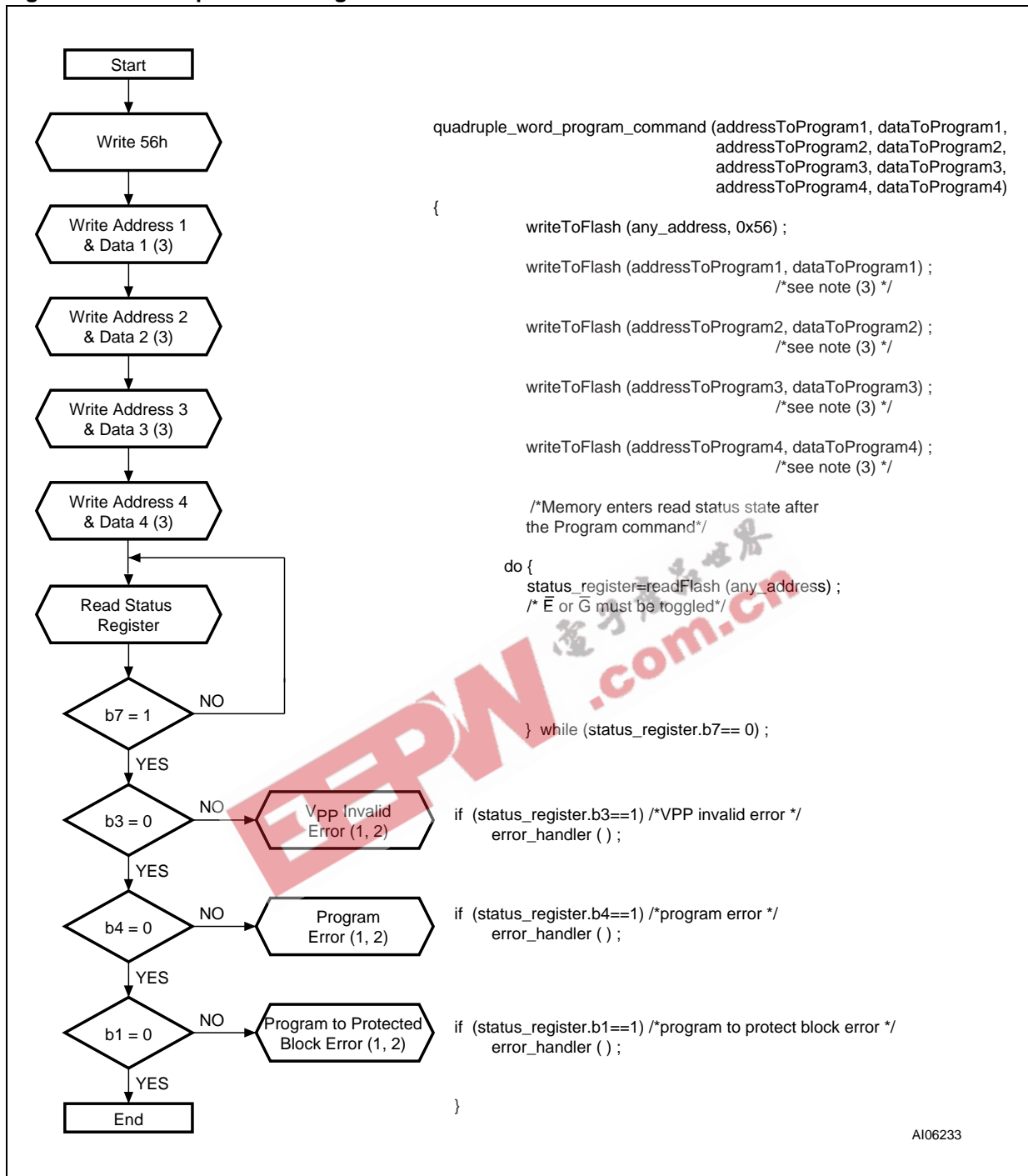

Note: 1. Status check of b1 (Protected Block), b3 (V_{PP} Invalid) and b4 (Program Error) can be made after each program operation or after a sequence.

2. If an error is found, the Status Register must be cleared before further Program/Erase operations.

3. Address 1 to Address 4 must be consecutive addresses differing only for bits A0 and A1.

Figure 19. Program Suspend & Resume Flowchart and Pseudo Code

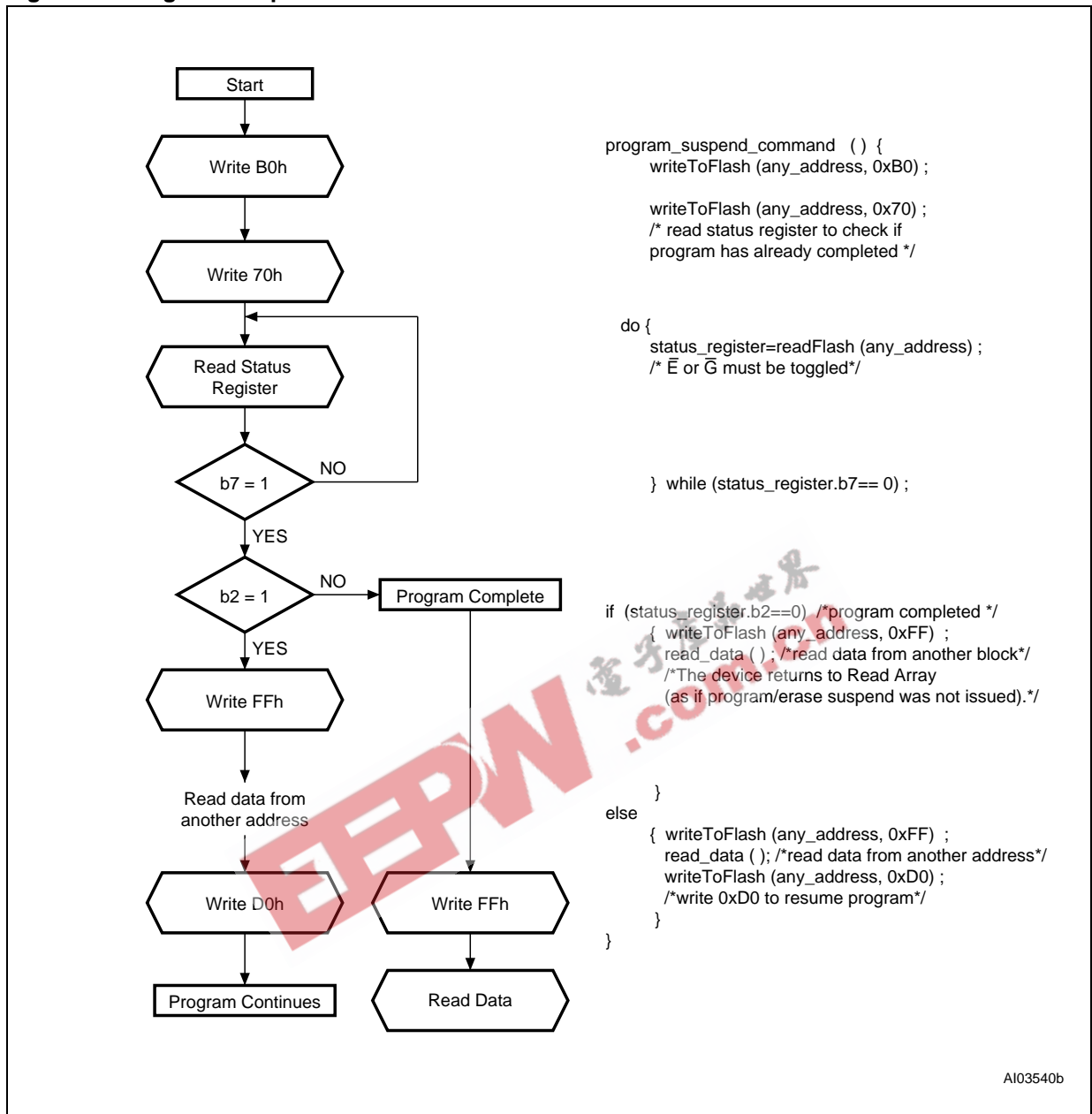
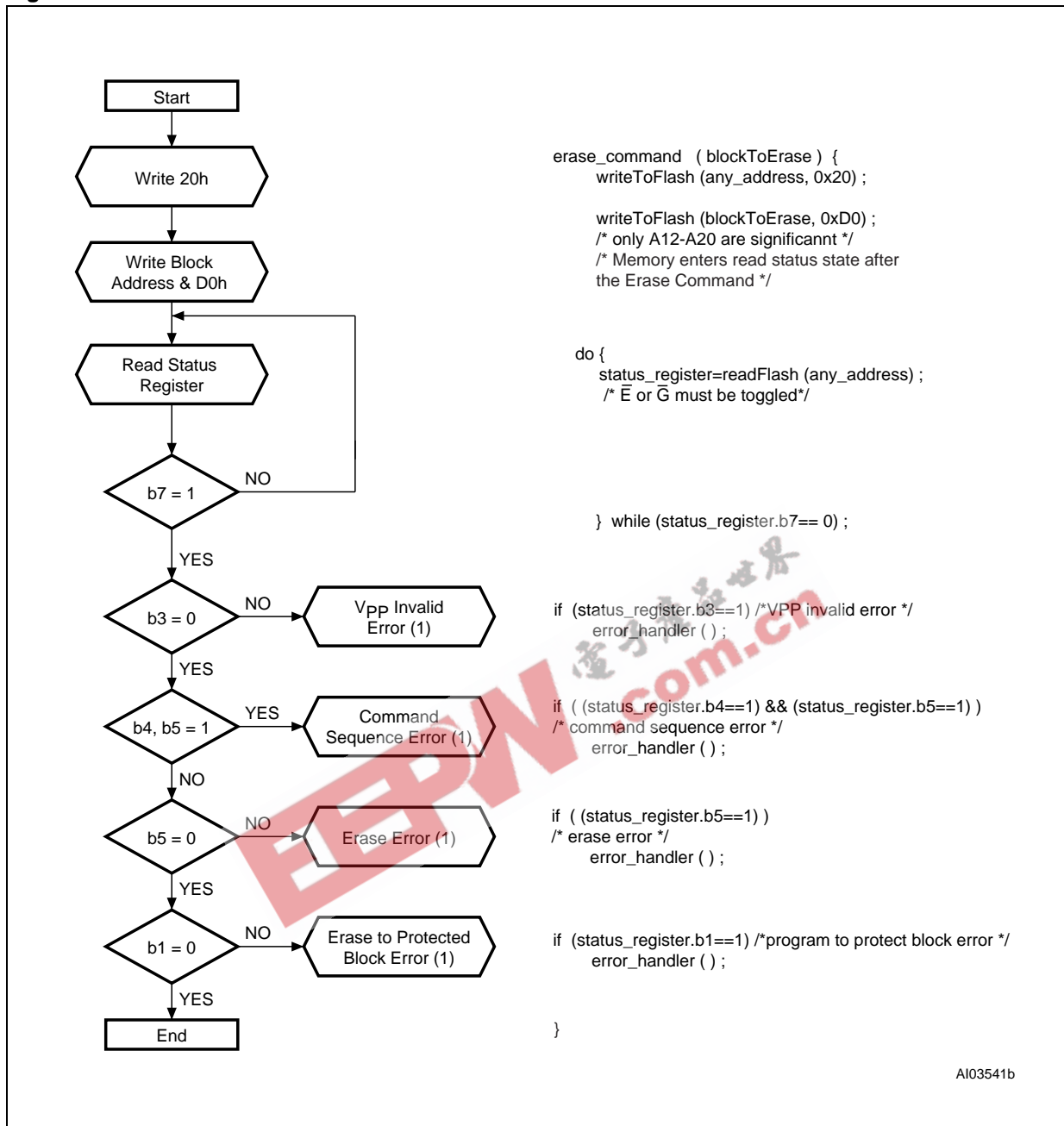
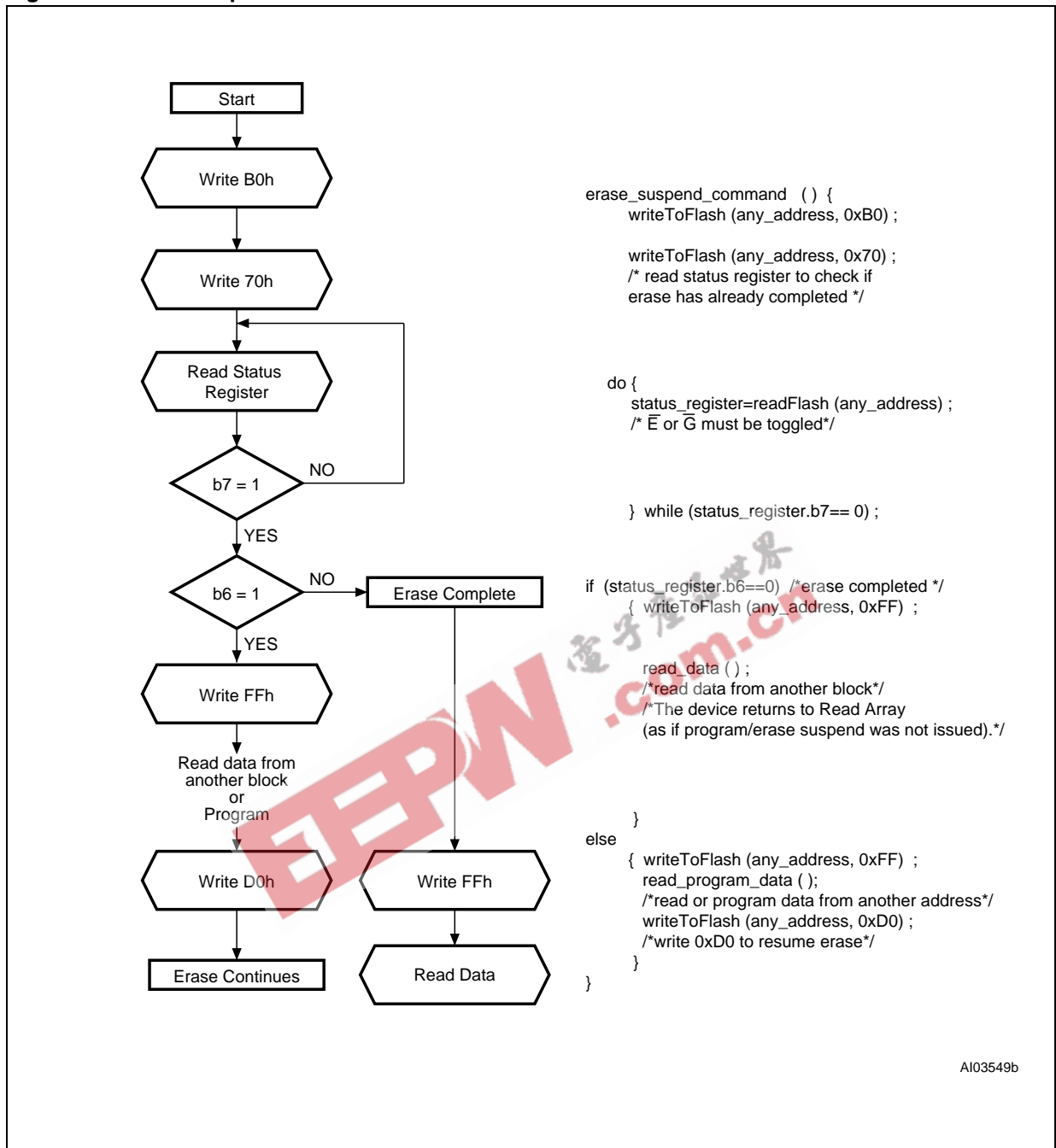

Figure 20. Erase Flowchart and Pseudo Code



Note: If an error is found, the Status Register must be cleared before further Program/Erase operations.

Figure 21. Erase Suspend & Resume Flowchart and Pseudo Code



AI03549b

APPENDIX D. COMMAND INTERFACE AND PROGRAM/ERASE CONTROLLER STATE

Table 29. Write State Machine Current/Next

Current State	SR bit 7	Data When Read	Command Input (and Next State)									
			Read Array (FFh)	Program Setup (10/40h)	Erase Setup (20h)	Erase Confirm (D0h)	Program/ Erase Suspend (B0h)	Program/ Erase Resume (D0h)	Read Status (70h)	Clear Status (50h)	Read Elect.Sg. (90h)	
Read Array	"1"	Array	Read Array	Program Setup	Erase Setup	Read Array			Read Status	Read Array	Read Elect.Sg.	
Read Status	"1"	Status	Read Array	Program Setup	Erase Setup	Read Array			Read Status	Read Array	Read Elect.Sg.	
Read Elect.Sg.	"1"	Electronic Signature	Read Array	Program Setup	Erase Setup	Read Array			Read Status	Read Array	Read Elect.Sg.	
Program Setup	"1"	Status	Program (Command input = Data to be Programmed)									
Program (continue)	"0"	Status	Program (continue)				Program Suspend to Read Status	Program (continue)				
Program Suspend to Read Status	"1"	Status	Program Suspend to Read Array	Program Suspend to Read Array		Program (continue)	Program Suspend to Read Array	Program (continue)	Program Suspend to Read Status	Program Suspend to Read Array	Program Suspend to Read Elect.Sg.	
Program Suspend to Read Array	"1"	Array	Program Suspend to Read Array	Program Suspend to Read Array		Program (continue)	Program Suspend to Read Array	Program (continue)	Program Suspend to Read Status	Program Suspend to Read Array	Program Suspend to Read Elect.Sg.	
Program Suspend to Read Elect.Sg.	"1"	Electronic Signature	Program Suspend to Read Array	Program Suspend to Read Array		Program (continue)	Program Suspend to Read Array	Program (continue)	Program Suspend to Read Status	Program Suspend to Read Array	Program Suspend to Read Elect.Sg.	
Program (complete)	"1"	Status	Read Array	Program Setup	Erase Setup	Read Array			Read Status	Read Array	Read Elect.Sg.	
Erase Setup	"1"	Status	Erase Command Error			Erase (continue)	Erase Command Error	Erase (continue)	Erase Command Error			
Erase Cmd. Error	"0"	Status	Read Array	Program Setup	Erase Setup	Read Array			Read Status	Read Array	Read Elect.Sg.	
Erase (continue)	"1"	Status	Erase (continue)				Erase Suspend to Read Status	Erase (continue)				
Erase Suspend to Read Status	"1"	Status	Erase Suspend to Read Array	Program Setup	Erase Suspend to Read Array	Erase (continue)	Erase Suspend to Read Array	Erase (continue)	Erase Suspend to Read Status	Erase Suspend to Read Array	Erase Suspend to Read Elect.Sg.	
Erase Suspend to Read Array	"1"	Array	Erase Suspend to Read Array	Program Setup	Erase Suspend to Read Array	Erase (continue)	Erase Suspend to Read Array	Erase (continue)	Erase Suspend to Read Status	Erase Suspend to Read Array	Erase Suspend to Read Elect.Sg.	
Erase Suspend to Read Elect.Sg.	"1"	Electronic Signature	Erase Suspend to Read Array	Program Setup	Erase Suspend to Read Array	Erase (continue)	Erase Suspend to Read Array	Erase (continue)	Erase Suspend to Read Status	Erase Suspend to Read Array	Erase Suspend to Read Elect.Sg.	
Erase (complete)	"1"	Status	Read Array	Program Setup	Erase Setup	Read Array			Read Status	Read Array	Read Elect.Sg.	

Note: Elect.Sg. = Electronic Signature.

REVISION HISTORY**Table 30. Document Revision History**

Date	Version	Revision Details
10-Sep-2001	-01	First Issue
06-Nov-2001	-02	V _{DDQ} Maximum changed to 3.3V Commands Table, Read CFI Query Address on 1st cycle changed to 'X' (Table 4)
17-Jun-2002	-03	Quadruple Word Program command added, V _{DDQ} Maximum changed to 3.6V, TFBGA package dimensions added to description. Corrections to Program and Erase times Table 7, DC Characteristics Table 12 and CFI Tables 25 and 26. Command Codes Table added.
3-Oct-2002	3.1	Revision numbering modified: a minor revision will be indicated by incrementing the digit after the dot, and a major revision, by incrementing the digit before the dot (revision version 03 equals 3.0). Revision History moved to end of document. "Double Word Program Command" and "Quadruple Word Program Command" clarified.

EEPW 电子产品世界
.com.cn



Information furnished is believed to be accurate and reliable. However, STMicroelectronics assumes no responsibility for the consequences of use of such information nor for any infringement of patents or other rights of third parties which may result from its use. No license is granted by implication or otherwise under any patent or patent rights of STMicroelectronics. Specifications mentioned in this publication are subject to change without notice. This publication supersedes and replaces all information previously supplied. STMicroelectronics products are not authorized for use as critical components in life support devices or systems without express written approval of STMicroelectronics.

The ST logo is registered trademark of STMicroelectronics
All other names are the property of their respective owners

© 2002 STMicroelectronics - All Rights Reserved

STMicroelectronics GROUP OF COMPANIES
Australia - Brazil - Canada - China - Finland - France - Germany - Hong Kong - India - Israel - Italy - Japan - Malaysia - Malta -
Morocco - Singapore - Spain - Sweden - Switzerland - United Kingdom - United States

www.st.com