

ANALOG MULTIPLEXER/DEMULTIPLEXER: SINGLE 8 CHANNEL, DUAL 4 CHANNEL, TRIPLE 2 CHANNEL

- **LOW POWER DISSIPATION**
 $I_{CC} = 4 \mu A$ (MAX.) AT $T_A = 25^\circ C$
- **LOGIC LEVEL TRANSLATION TO ENABLE 5V LOGIC SIGNAL TO COMMUNICATE WITH $\pm 5V$ ANALOG SIGNAL**
- **LOW "ON" RESISTANCE:**
 70Ω TYP. ($V_{CC} - V_{EE} = 4.5 V$)
 50Ω TYP. ($V_{CC} - V_{EE} = 9 V$)
- **WIDE ANALOG INPUT VOLTAGE RANGE: $\pm 6V$**
- **FAST SWITCHING:**
 $t_{pd} = 15 ns$ (TYP.) AT $T_A = 25^\circ C$
- **LOW CROSSTALK BETWEEN SWITCHES**
- **HIGH ON/OFF OUTPUT VOLTAGE RATIO**
- **WIDE OPERATING VOLTAGE RANGE**
 $(V_{CC} - V_{EE}) = 2V$ TO $12V$
- **LOW SINE WAVE DISTORTION**
 0.02% AT $V_{CC} - V_{EE} = 9V$
- **HIGH NOISE IMMUNITY**
 $V_{NIH} = V_{NIL} = 28\% V_{CC}$ (MIN.)
- **PIN AND FUNCTION COMPATIBLE WITH HCC/HCF4051/4052/4053B**

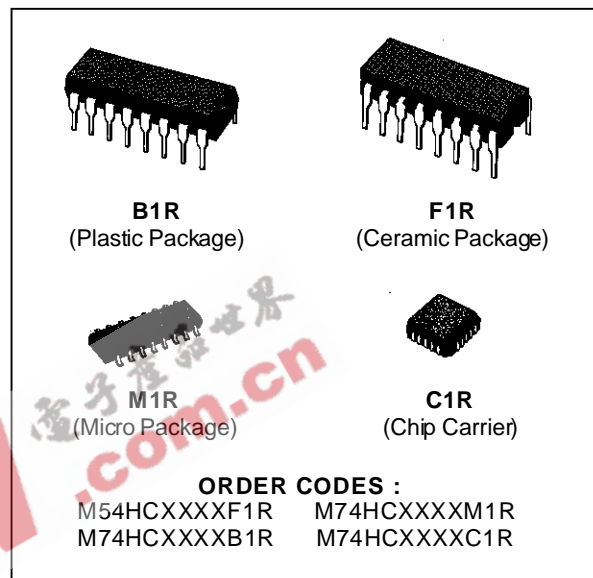

DESCRIPTION

These devices are analog multiplexer demultiplexers in high speed silicon gate C²MOS technology and they are pin compatible with the equivalent metal gate CMOS "4000B" series. These analog switches are bidirectional and digitally

controlled.

A built-in level shifting is included to allow them an input range of up to $\pm 6V$ (peak) for an analog signal with digital control signal of 0 to 6V.

V_{EE} supply pin is provided for analog input signals. They have an inhibit (INH) input terminal to disable all the switches when high. For operation as a digital multiplexer/demultiplexer, V_{EE} is connected to GND.

PIN CONNECTION (top view)

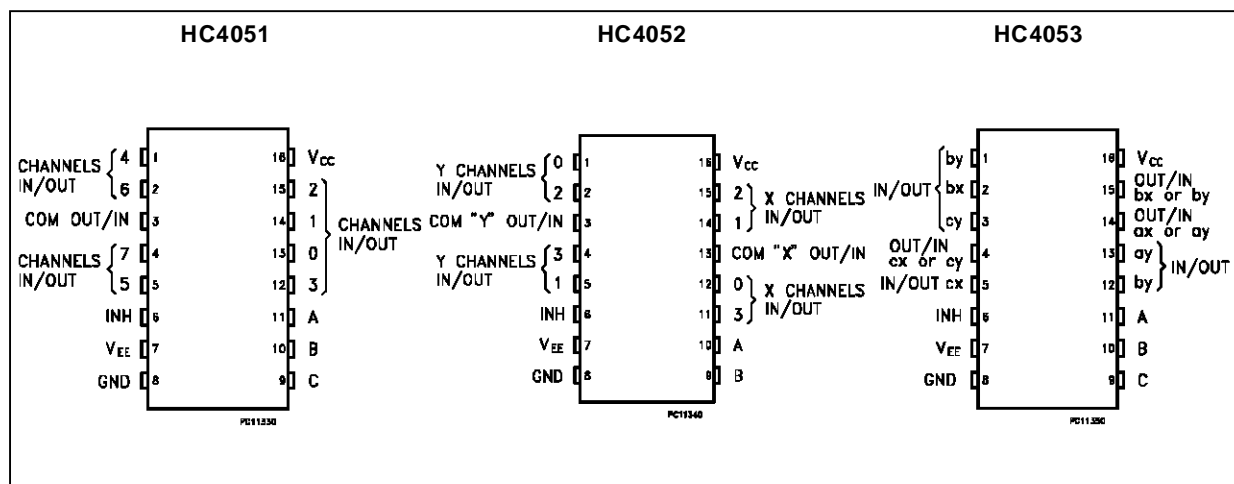

M54/M74HC4051/4052/4053

DESCRIPTION

The HC4051 is a single 8 channel multiplexer demultiplexer having three binary control inputs A, B and C to select 1 of 8 to be turned on, and connected to the output.

The HC4052 has a pair of four channel multiplexer demultiplexer having two control inputs A and B that

select one of four channels of the two sections.

The HC4053 is a triple two channel multiplexer demultiplexer having three separate digital control inputs A, B and C to select independently one of a pair of channels.

CHIP CARRIER

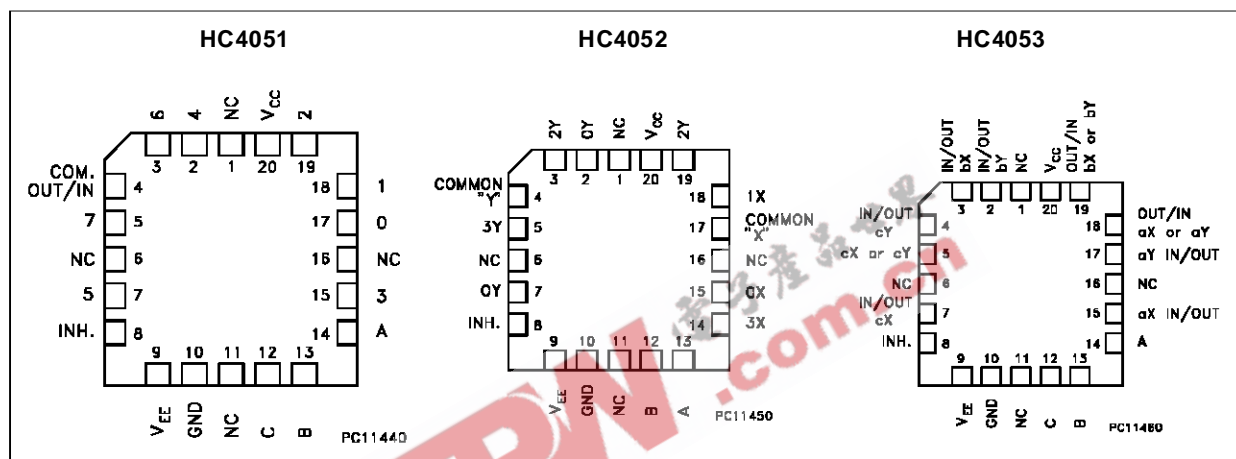

TRUTH TABLE (HC4051)

INPUT STATES				"ON" CHANNEL
INHIBIT	C	B	A	
L	L	L	L	0
L	L	L	H	1
L	L	H	L	2
L	L	H	H	3
L	H	L	L	4
L	H	L	H	5
L	H	H	L	6
L	H	H	H	7
H	X	X	X	NONE

X: DON'T CARE

TRUTH TABLE (HC4052)

INPUT STATES			"ON" CHANNELS
INHIBIT	B	A	
L	L	L	0X, 0Y
L	L	H	1X, 1Y
L	H	L	2X, 2Y
L	H	H	3X, 3Y
H	X	X	NONE

X: DON'T CARE

TRUTH TABLE (HC4053)

INPUT STATES		"ON" CHANNELS
INHIBIT	A or B or C	
L	L	ax or bx or cx
L	H	ay or by or cy
H	X	NONE

X: DON'T CARE

IEC LOGIC SYMBOLS

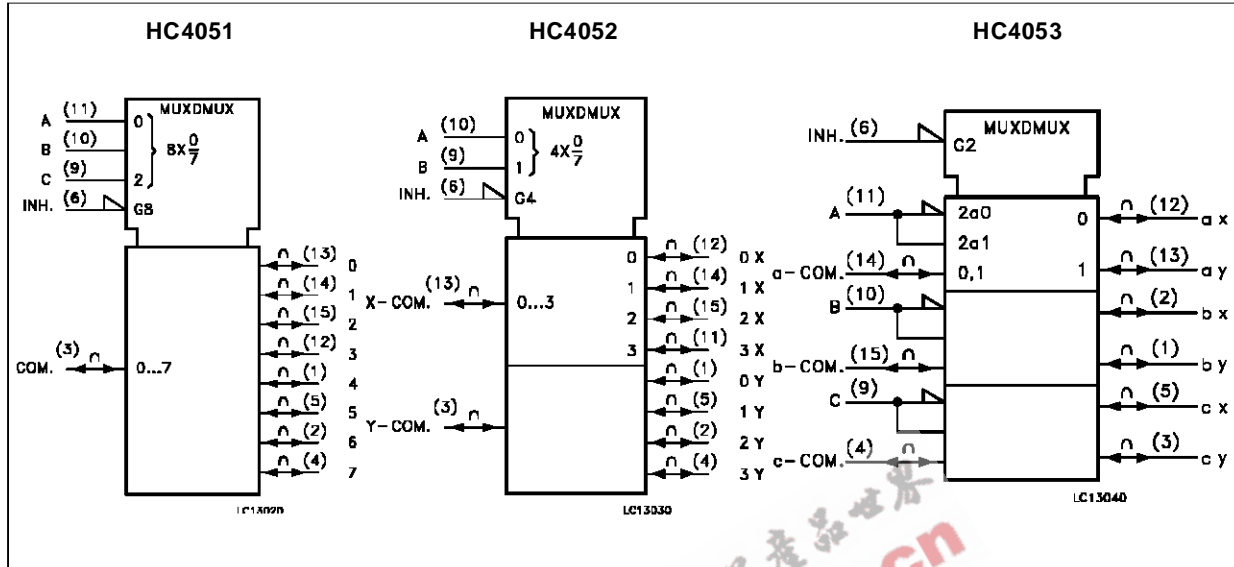

PIN DESCRIPTION (HC4051)

PIN No	SYMBOL	NAME AND FUNCTION
3	COM OUT/IN	Common Output/input
6	INH	INHIBIT Input
7	V _{EE}	Negative Supply Voltage
11, 10, 9	A, B, C	Select Inputs
13, 14, 15, 12, 1, 5, 2, 4	0 TO 7	Independent Input/Outputs
8	GND	Ground (0V)
16	V _{CC}	Positive Supply Voltage

PIN DESCRIPTION (HC4052)

PIN No	SYMBOL	NAME AND FUNCTION
1, 5, 2, 4	0Y TO 3Y	Independent Input/Outputs
6	INH	INHIBIT Input
7	V _{EE}	Negative Supply Voltage
10, 9	A, B	Select Inputs
12, 14, 15, 11	0X TO 3X	Independent Input/Outputs
3	COM Y OUT/IN	Common X Output/input
13	COM X OUT/IN	Common Y Output/input
8	GND	Ground (0V)
16	V _{CC}	Positive Supply Voltage

PIN DESCRIPTION (HC4053)

PIN No	SYMBOL	NAME AND FUNCTION
2, 1	bx, by	Independent Input/Outputs
5, 3	cx, cy	Independent Input/Outputs
6	INH	INHIBIT Input
7	V _{EE}	Negative Supply Voltage
11, 10, 9	A, B, C	Select Inputs
12, 13	ax, ay	Independent Input/Outputs
14, 15, 4	ax TO cy	Common Output/input
8	GND	Ground (0V)
16	V _{CC}	Positive Supply Voltage

M54/M74HC4051/4052/4053

FUNCTIONAL DIAGRAM

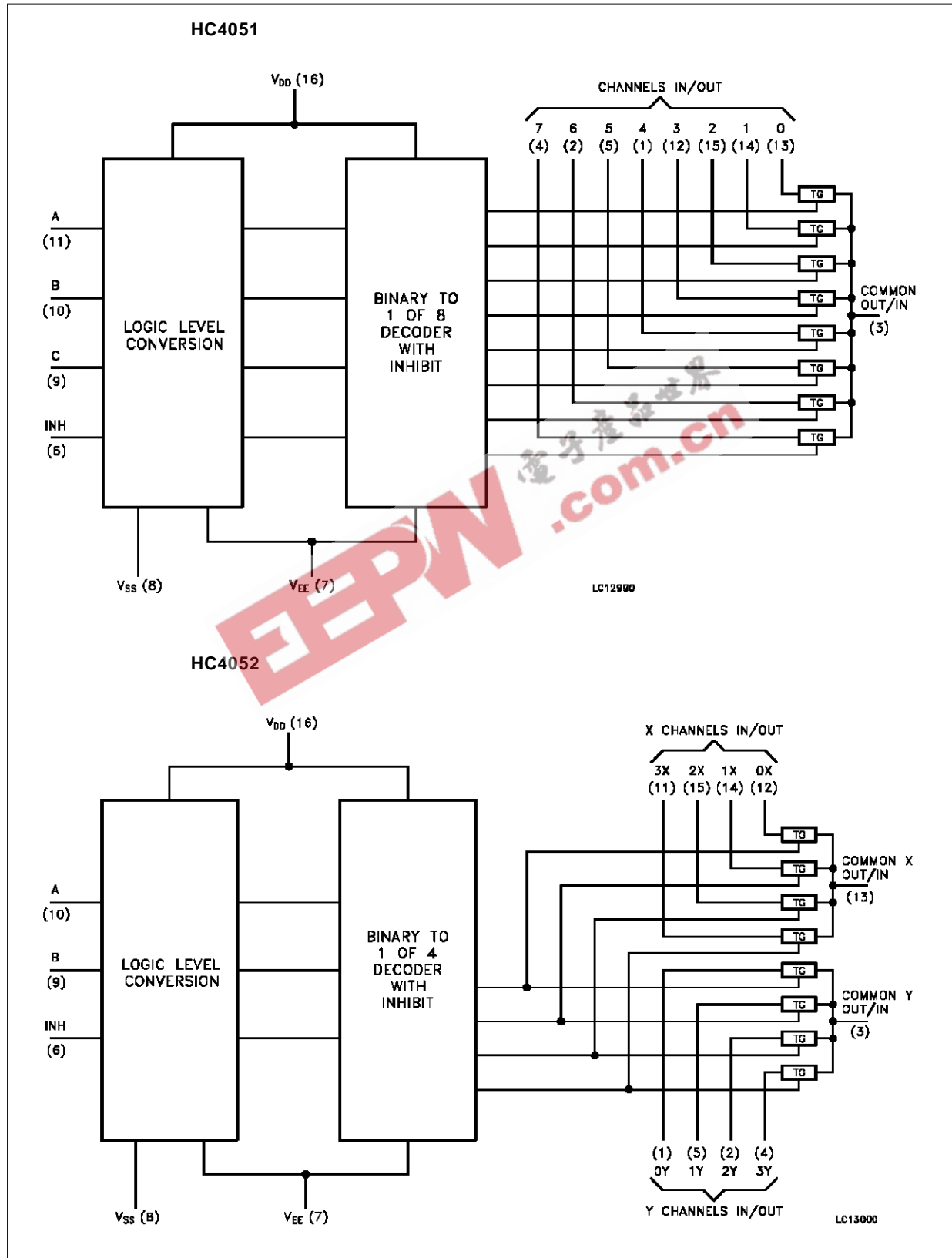

FUNCTIONAL DIAGRAM

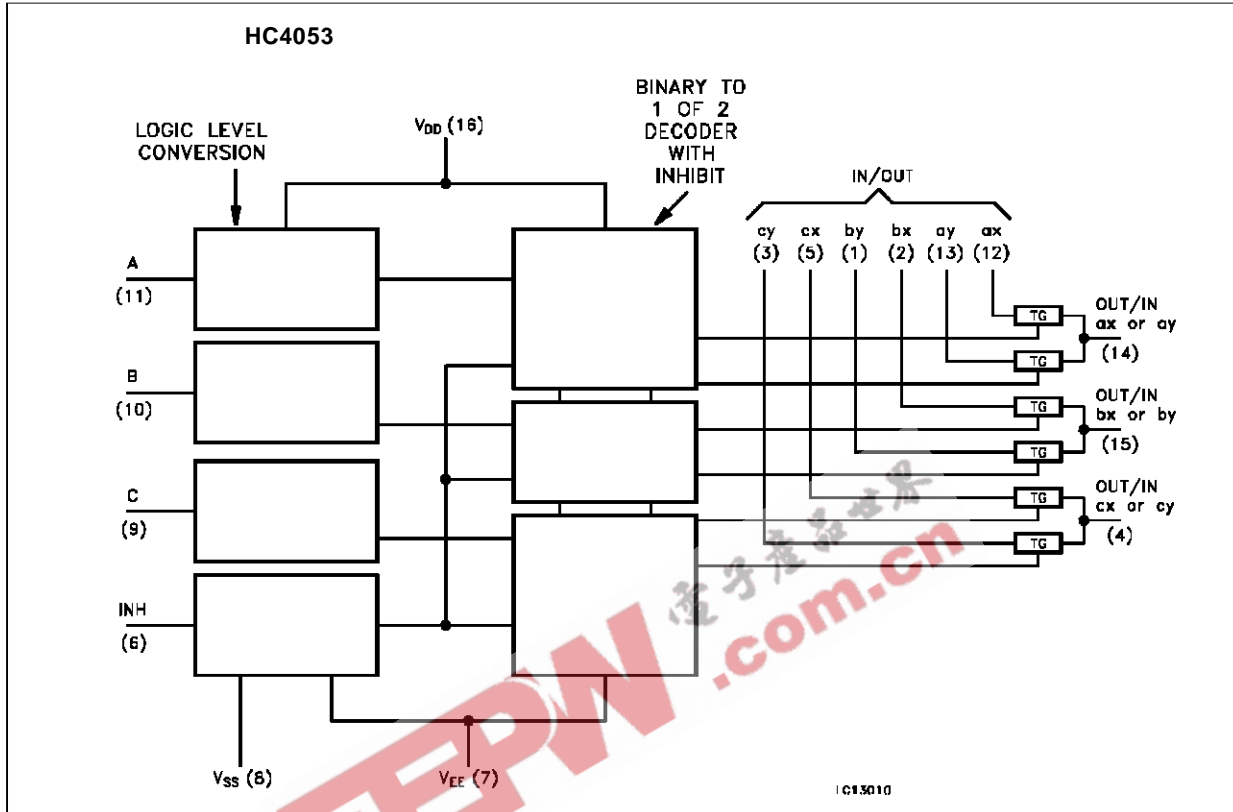

ABSOLUTE MAXIMUM RATINGS

Symbol	Parameter	Value	Unit
V_{CC}	Supply Voltage Range	-0.5 to +7	V
$V_{CC} - V_{EE}$	Supply Voltage Range	-0.5 to 13	V
V_{IN}	Control Input Voltage	-0.5 to $V_{CC} + 0.5$	V
$V_{I/O}$	Switch I/O Voltage	$V_{EE} - 0.5$ to $V_{CC} + 0.5$	V
I_{CK}	Control Input Diode Current	± 20	mA
$I_{I/OK}$	I/O Diode Current	± 20	mA
I_T	Switch Through Current	± 25	mA
I_{CC}	DC V_{CC} or Ground Current	± 50	mA
P_D	Power Dissipation	500 (*)	mW
T_{stg}	Storage Temperature	-65 to +150	$^{\circ}C$
T_L	Lead Temperature (10 sec)	300	$^{\circ}C$

Absolute Maximum Ratings are those values beyond which damage to the device may occur. Functional operation under these conditions is not implied.

(*) 500 mW: $\cong 65^{\circ}C$ derate to 300 mW by 10mW/ $^{\circ}C$: $65^{\circ}C$ to $85^{\circ}C$

M54/M74HC4051/4052/4053

RECOMMENDED OPERATING CONDITIONS

Symbol	Parameter	Value	Unit	
V_{CC}	Supply Voltage	2 to 6	V	
V_{EE}	Supply Voltage	-6 to 0	V	
$V_{CC} - V_{EE}$	Supply Voltage	2 to 12	V	
V_{IN}	Input Voltage	0 to V_{CC}	V	
$V_{I/O}$	Input/Output Voltage	V_{EE} to V_{CC}	V	
T_{op}	Operating Temperature: M54HC Series M74HC Series	-55 to +125 -40 to +85	°C °C	
t_r, t_f	Input Rise and Fall Time	$V_{CC} = 2\text{ V}$	0 to 1000	ns
		$V_{CC} = 4.5\text{ V}$	0 to 500	
		$V_{CC} = 6\text{ V}$	0 to 400	

DC SPECIFICATIONS

Symbol	Parameter	Test Conditions			Value						Unit	
		V_{CC} (V)	V_{EE} (V)		$T_A = 25\text{ °C}$ 54HC and 74HC		$-40\text{ to }85\text{ °C}$ 74HC		$-55\text{ to }125\text{ °C}$ 54HC			
					Min.	Typ.	Max.	Min.	Max.	Min.		Max.
V_{IHC}	High Level Control Input Voltage	2.0			1.5			1.5		1.5		V
		4.5			3.15			3.15		3.15		
		6.0			4.2			4.2		4.2		
V_{ILC}	Low Level Control Input Voltage	2.0					0.5		0.5		0.5	V
		4.5					1.35		1.35		1.35	
		6.0					1.8		1.8		1.8	
R_{ON}	ON Resistance	4.5	GND	$V_{IN} = V_{IHC}$ or V_{ILC}	85	180		225		270	Ω	
		4.5	-4.5	$V_{I/O} = V_{CC}$ or V_{EE}	55	120		150		180		
		6.0	-6.0	$I_{I/O} \leq 2\text{ mA}$	50	100		125		150		
		2.0	GND	$V_{IN} = V_{IHC}$ or V_{ILC}	150							
		4.5	GND	$V_{I/O} = V_{CC}$ or V_{EE}	70	150		190		230		
		4.5	-4.5	$I_{I/O} \leq 2\text{ mA}$	50	100		125		150		
		6.0	-6.0		45	80		100		120		
ΔR_{ON}	Difference of ON Resistance Between Switches	4.5	GND	$V_{IN} = V_{IHC}$ or V_{ILC}	10	30		35		45	Ω	
		4.5	-4.5	$V_{I/O} = V_{CC}$ or V_{EE}	5	12		15		18		
		6.0	-6.0	$I_{I/O} \leq 2\text{ mA}$	5	10		12		15		
I_{OFF}	Input/Output Leakage Current (SWITCH OFF)	6.0	GND	$V_{OS} = V_{CC}$ or GND		± 0.06		± 0.6		± 1.2	μA	
		6.0	-6.0	$V_{IS} = \text{GND}$ or V_{CC} $V_{IN} = V_{ILC}$ or V_{IHC}		± 0.1		± 1		± 2		
I_{IZ}	Switch Input Leakage Current (SWITCH ON, OUTPUT OPEN)	6.0	GND	$V_{OS} = V_{CC}$ or GND		± 0.06		± 0.6		± 1.2	μA	
		6.0	-6.0	$V_{IN} = V_{IHC}$ or V_{ILC}		± 0.1		± 1		± 2		
I_{IN}	Control Input Current	6.0	GND	$V_{IN} = V_{CC}$ or GND		± 0.1		± 0.1		± 1	μA	
I_{CC}	Quiescent Supply Current	6.0	GND	$V_{IN} = V_{CC}$ or GND		4		40		80	μA	
		6.0	-6.0			8		80		160		

AC ELECTRICAL CHARACTERISTICS ($C_L = 50 \text{ pF}$, Input $t_r = t_f = 6 \text{ ns}$)

Symbol	Parameter	Test Conditions			Value						Unit	
		V _{CC} (V)	V _{EE} (V)		T _A = 25 °C 54HC and 74HC			-40 to 85 °C 74HC		-55 to 125 °C 54HC		
					Min.	Typ.	Max.	Min.	Max.	Min.		Max.
Φ _{I/O}	Phase Difference Between Input and Output	2.0	GND			25	60		75		90	ns
		4.5	GND			6	12		15		18	
		6.0	GND			5	10		13		15	
		4.5	-4.5			4						
t _{PZL} t _{PHZ}	Output Enable Time (for 4051/4052)	2.0	GND	R _L = 1KΩ		64	225		280		340	ns
		4.5	GND			18	45		56		68	
		6.0	GND			15	38		48		58	
		4.5	-4.5			18						
t _{PZL} t _{PHZ}	Output Enable Time (for 4053)	2.0	GND	R _L = 1KΩ		50	225		280		340	ns
		4.5	GND			14	45		56		68	
		6.0	GND			12	38		48		58	
		4.5	-4.5			14						
t _{PLZ} t _{PHZ}	Output Disable Time (for 4051/4052)	2.0	GND	R _L = 1KΩ		100	250		315		375	ns
		4.5	GND			33	50		63		7	
		6.0	GND			28	43		54		64	
		4.5	-4.5			29						
t _{PLZ} t _{PHZ}	Output Disable Time (for 4053)	2.0	GND	R _L = 1KΩ		95	225		280		340	ns
		4.5	GND			30	45		56		68	
		6.0	GND			26	38		48		58	
		4.5	-4.5			26						
C _{IN}	Input Capacitance					5	10		10		10	pF
C _{I/O}	Common Terminal Capacitance	5.0	-5.0	HC4051		36	70		70		70	pF
				HC4052		19	40		40		40	
				HC4053		11	20		20		20	
C _{I/O}	Switch Terminal Capacitance	5.0	-5.0	HC4051		7	15		15		15	pF
				HC4052		7	15		15		15	
				HC4053		7	15		15		15	
C _{IOS}	Feed Through Capacitance	5.0	-5.0	HC4051		0.95	2		2		2	pF
				HC4052		0.85	2		2		2	
				HC4053		0.75	2		2		2	
C _{PD} (*)	Power Dissipation Capacitance	5.0	GND	HC4051		70						pF
HC4052		71										
HC4053		67										

(*) C_{PD} is defined as the value of the IC's internal equivalent capacitance which is calculated from the operating current consumption without load. (Refer to Test Circuit). Average operating current can be obtained by the following equation. $I_{CC(opr)} = C_{PD} \cdot V_{CC} \cdot f_{IN} + I_{CC}$

M54/M74HC4051/4052/4053

ANALOG SWITCH CHARACTERISTICS (GND = 0 V T_A = 25 °C)

Symbol	Parameter	Test Conditions			Value	Unit	
		V _{CC} (V)	V _{EE} (V)	V _{IN} (Vp-p)	Typ.		
	Sine Wave Distortion	2.25	2.25	4	f _{IN} = 1 KHz R _L = 10 KΩ C _L = 50 pF	0.025	
		4.5	-4.5	8		0.020	
		6.0	-6.0	11		0.018	
f _{MAX}	Frequency Response (Switch ON)	2.25	-2.25	Adjust f _{IN} voltage to Obtain 0 dBm at V _{OS} . Increase f _{IN} Frequency until dB Meter Reads -3dB R _L = 50 Ω C _L = 10 pF f _{IN} = 1 KHz sine wave	ALL (*)	120	MHz
					HC4051 (**)	45	
					HC4052 (**)	70	
		HC4053 (**)	95				
		4.5	-4.5		ALL (*)	190	
					HC4051 (**)	70	
					HC4052 (**)	110	
		6.0	-6.0		ALL (*)	200	
					HC4051 (**)	85	
					HC4052 (**)	140	
		HC4053 (**)	190				
			Feedthrough Attenuation (Switch OFF)		2.25	-2.25	
4.5	-4.5			-50			
6.0	-6.0			-50			
	Crosstalk (Control Input to Signal Output)	2.25	-2.25	Adjust R _L at set up so that I _S = 0A R _L = 600 Ω C _L = 50 pF f _{IN} = 1 MHz square wave	60	mV	
		4.5	-4.5		140		
		6.0	-6.0		200		
	Crosstalk (Between Any Switches)	2.25	-2.25	Adjust V _{IN} to Obtain 0 dBm at Input R _L = 600 Ω C _L = 50 pF f _{IN} = 1 MHz sine wave	-50	dB	
		4.5	-4.5		-50		
		6.0	-6.0		-50		

(*): Input COMMON Terminal, and measured at SWITCH Terminal.

(**): Input SWITCH Terminal, and measured at COMMON Terminal.

NOTE: These characteristics are determined by design of devices.

SWITCHING CHARACTERISTICS TEST CIRCUIT

t_{PLZ} , t_{PHZ} , t_{PZL} , t_{PZH} .

t_{PLZ} , t_{PHZ} , t_{PZL} , t_{PZH}

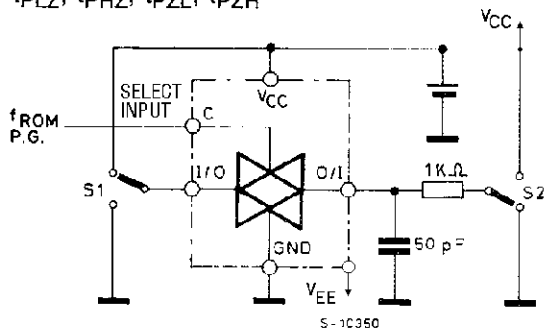

CROSSTALK (control to output)

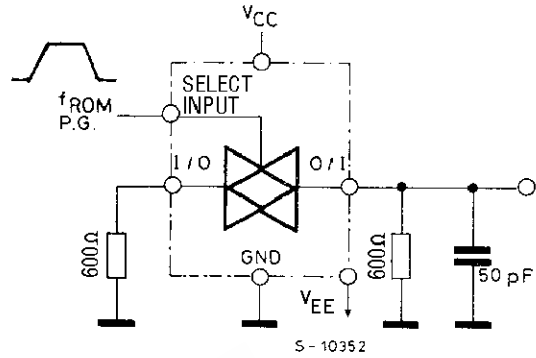

BANDWIDTH AND FEEDTHROUGH ATTENUATION

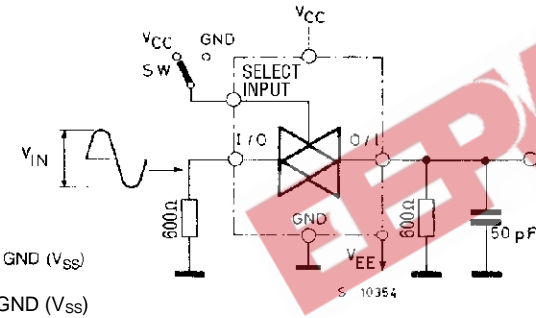

CROSSTALK BETWEEN ANY TWO SWITCHES

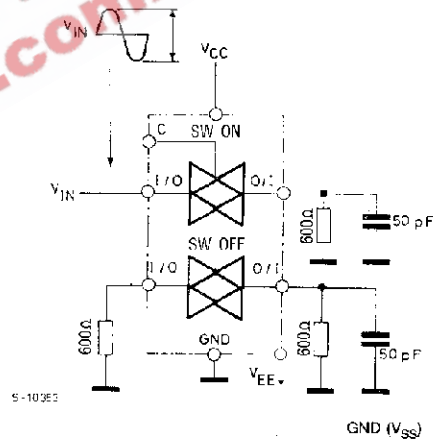

C_{I-O} , $C_{I/O}$

C_{I-O} , $C_{I/O}$

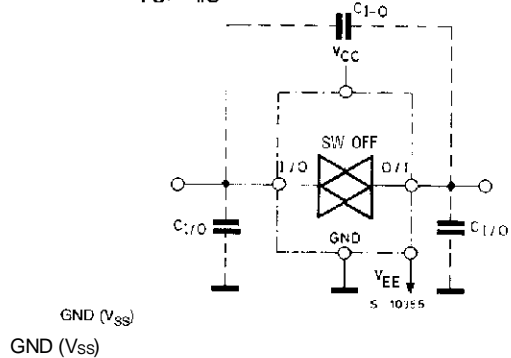

SWITCHING CHARACTERISTICS TEST WAVEFORM

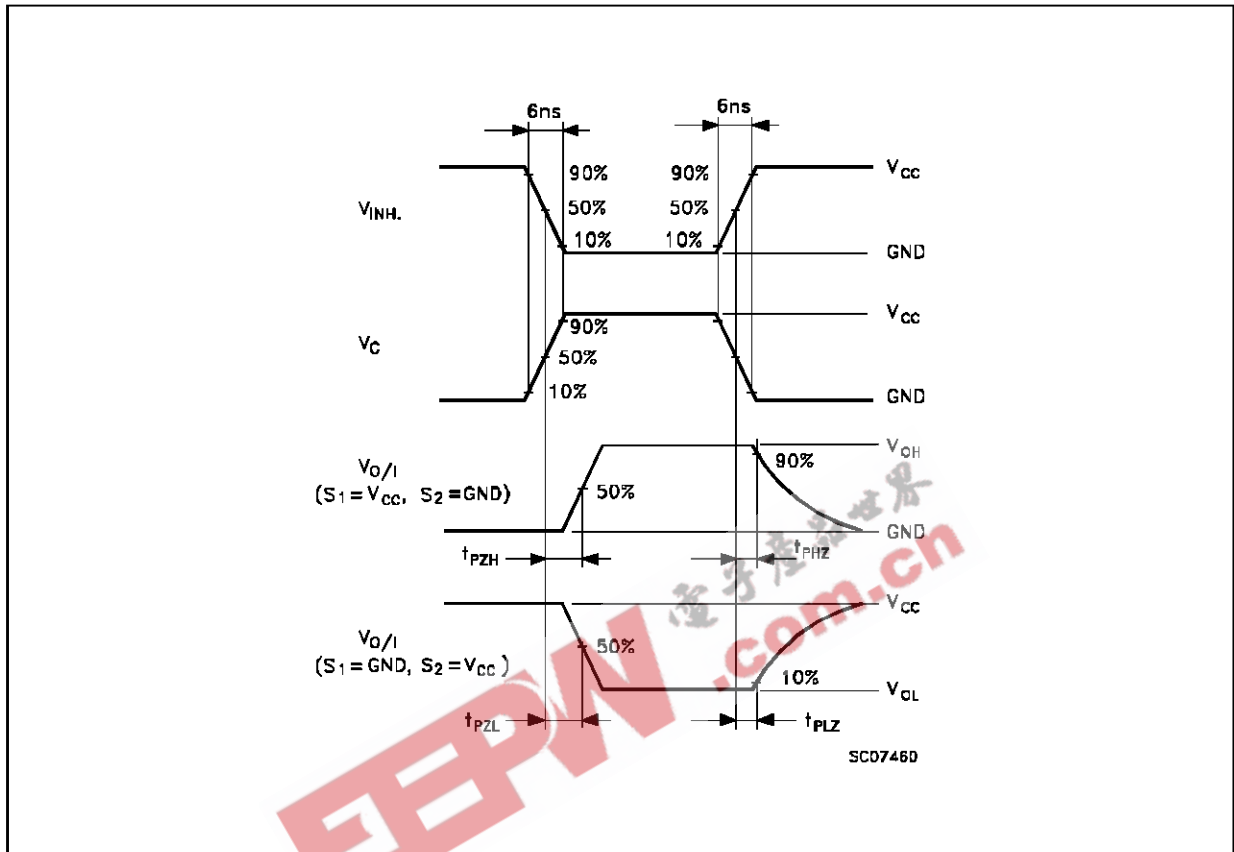

CHANNEL RESISTANCE (R_{ON})

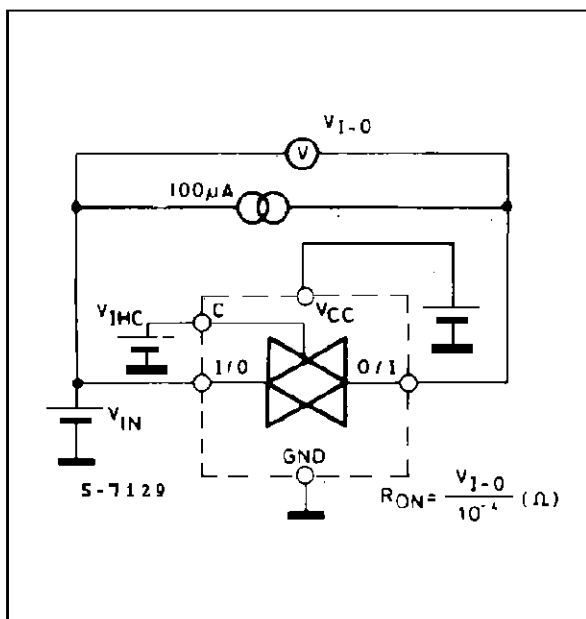

I_{CC} (Opr.)

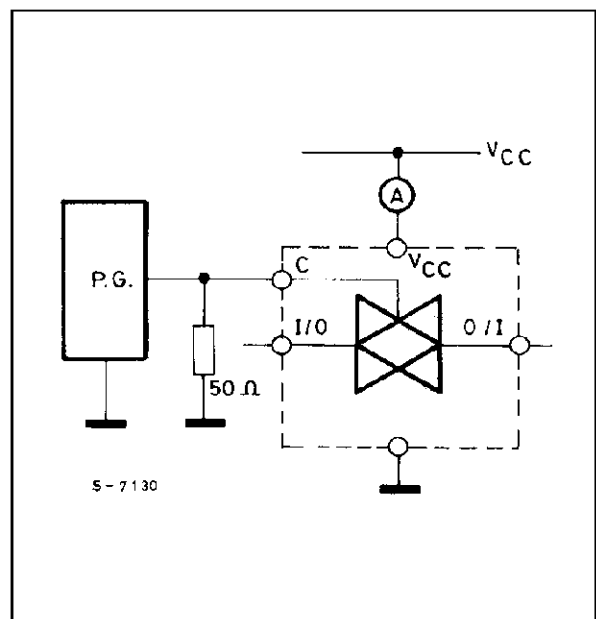

Plastic DIP16 (0.25) MECHANICAL DATA

DIM.	mm			inch		
	MIN.	TYP.	MAX.	MIN.	TYP.	MAX.
a1	0.51			0.020		
B	0.77		1.65	0.030		0.065
b		0.5			0.020	
b1		0.25			0.010	
D			20			0.787
E		8.5			0.335	
e		2.54			0.100	
e3		17.78			0.700	
F			7.1			0.280
I			5.1			0.201
L		3.3			0.130	
Z			1.27			0.050

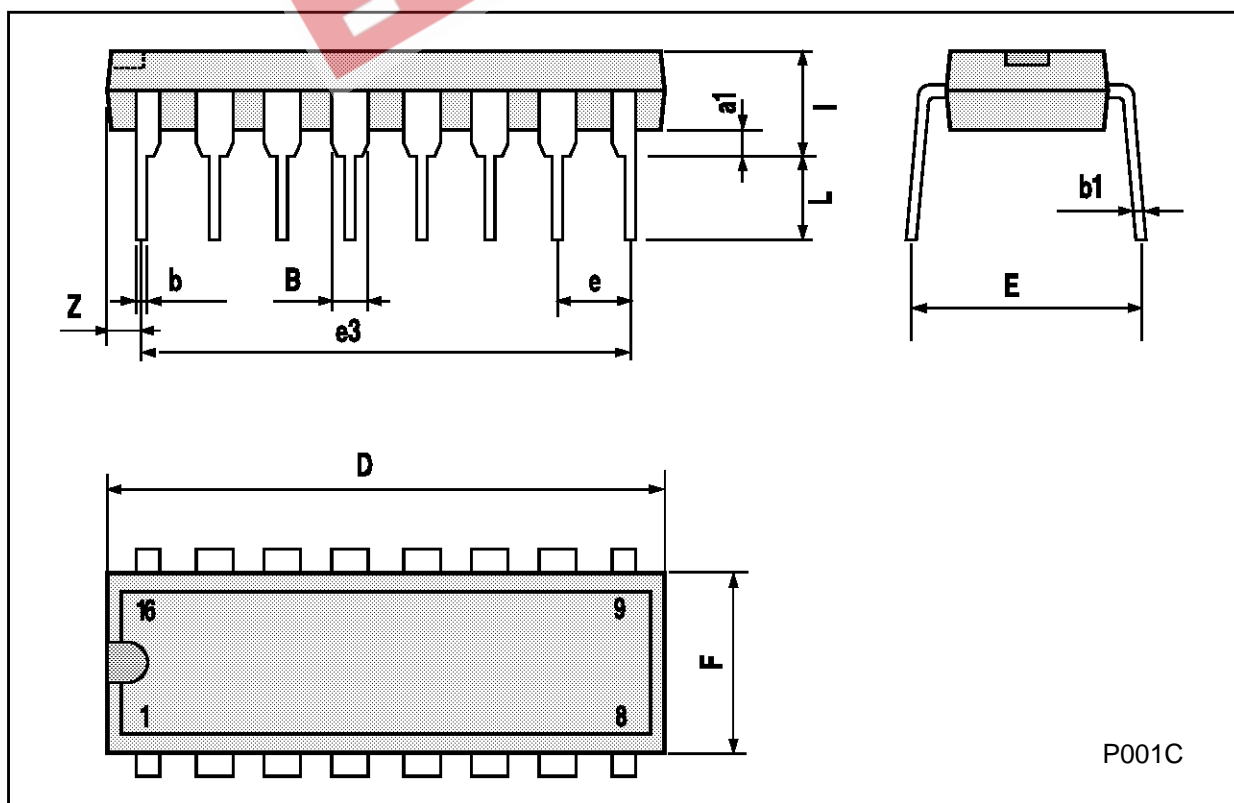

M54/M74HC4051/4052/4053

Ceramic DIP16/1 MECHANICAL DATA

DIM.	mm			inch		
	MIN.	TYP.	MAX.	MIN.	TYP.	MAX.
A			20			0.787
B			7			0.276
D		3.3			0.130	
E	0.38			0.015		
e3		17.78			0.700	
F	2.29		2.79	0.090		0.110
G	0.4		0.55	0.016		0.022
H	1.17		1.52	0.046		0.060
L	0.22		0.31	0.009		0.012
M	0.51		1.27	0.020		0.050
N			10.3			0.406
P	7.8		8.05	0.307		0.317
Q			5.08			0.200

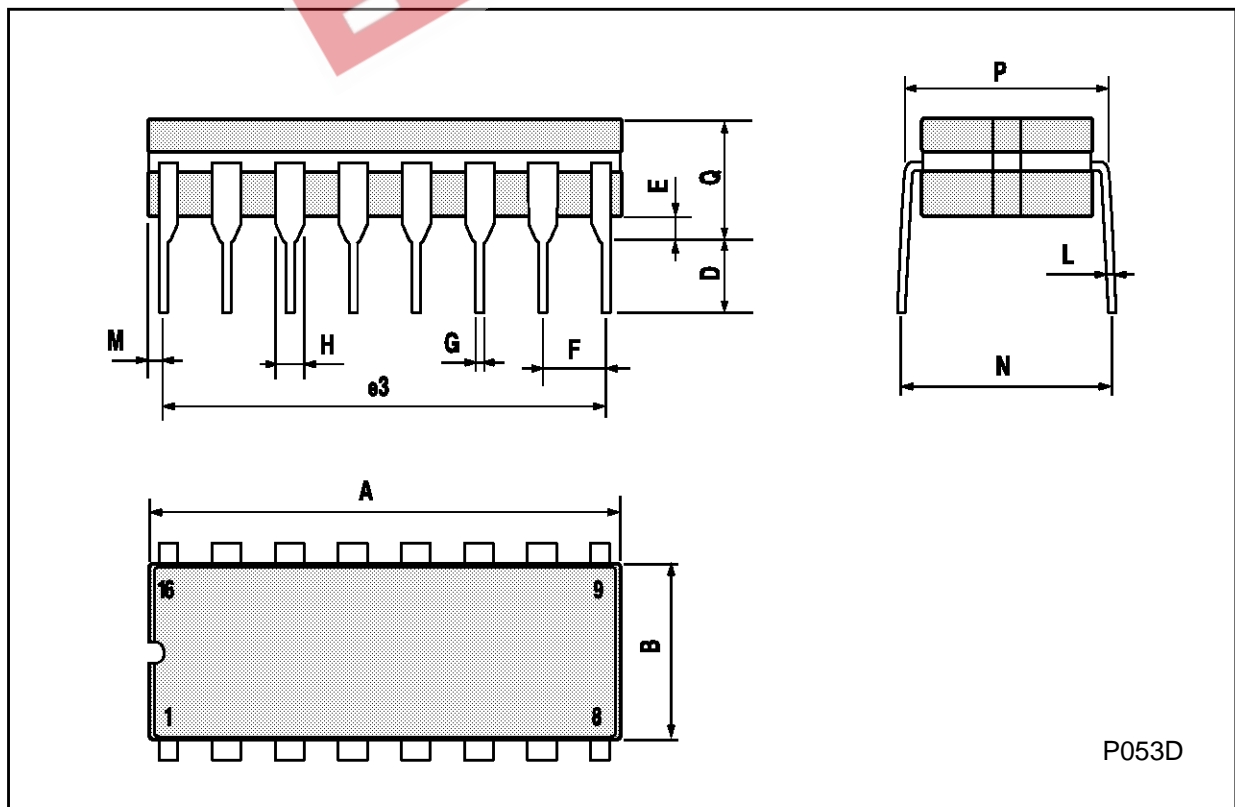

SO16 (Narrow) MECHANICAL DATA

DIM.	mm			inch		
	MIN.	TYP.	MAX.	MIN.	TYP.	MAX.
A			1.75			0.068
a1	0.1		0.2	0.004		0.007
a2			1.65			0.064
b	0.35		0.46	0.013		0.018
b1	0.19		0.25	0.007		0.010
C		0.5			0.019	
c1	45° (typ.)					
D	9.8		10	0.385		0.393
E	5.8		6.2	0.228		0.244
e		1.27			0.050	
e3		8.89			0.350	
F	3.8		4.0	0.149		0.157
G	4.6		5.3	0.181		0.208
L	0.5		1.27	0.019		0.050
M			0.62			0.024
S	8° (max.)					

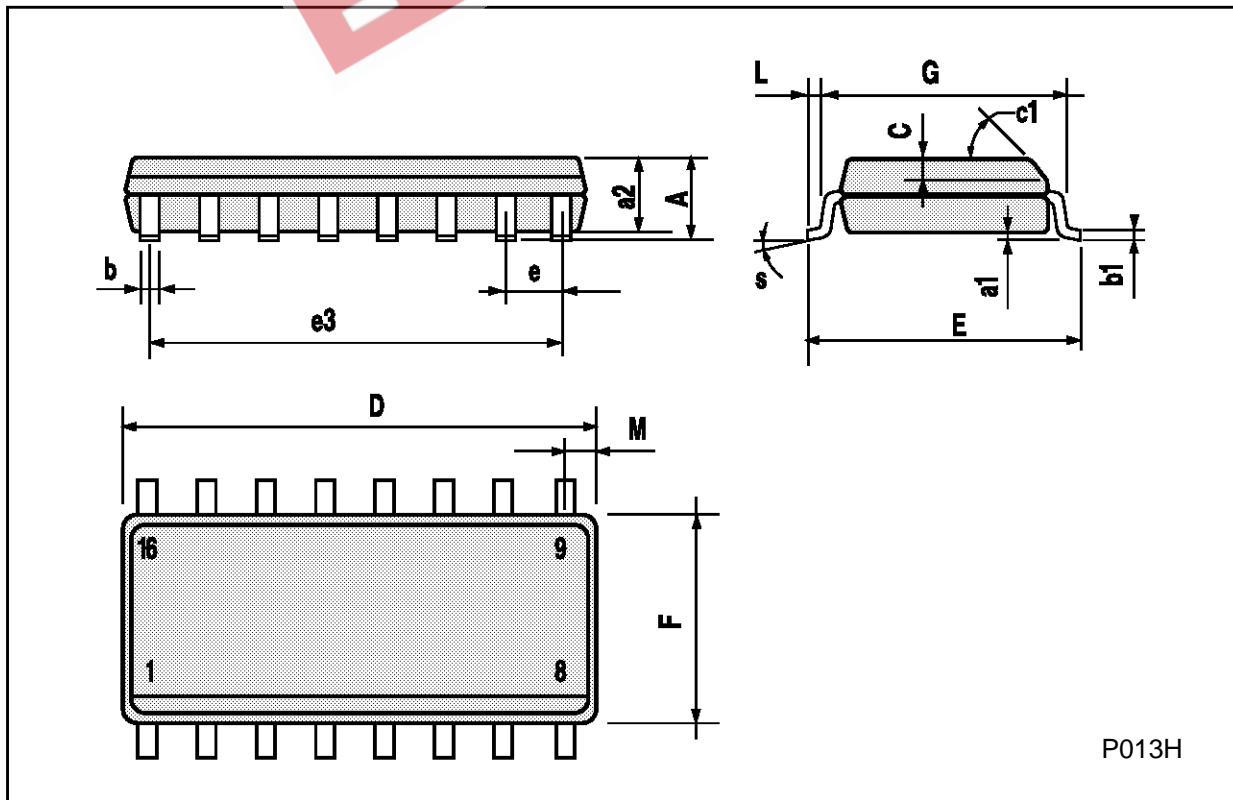

PLCC20 MECHANICAL DATA

DIM.	mm			inch		
	MIN.	TYP.	MAX.	MIN.	TYP.	MAX.
A	9.78		10.03	0.385		0.395
B	8.89		9.04	0.350		0.356
D	4.2		4.57	0.165		0.180
d1		2.54			0.100	
d2		0.56			0.022	
E	7.37		8.38	0.290		0.330
e		1.27			0.050	
e3		5.08			0.200	
F		0.38			0.015	
G			0.101			0.004
M		1.27			0.050	
M1		1.14			0.045	

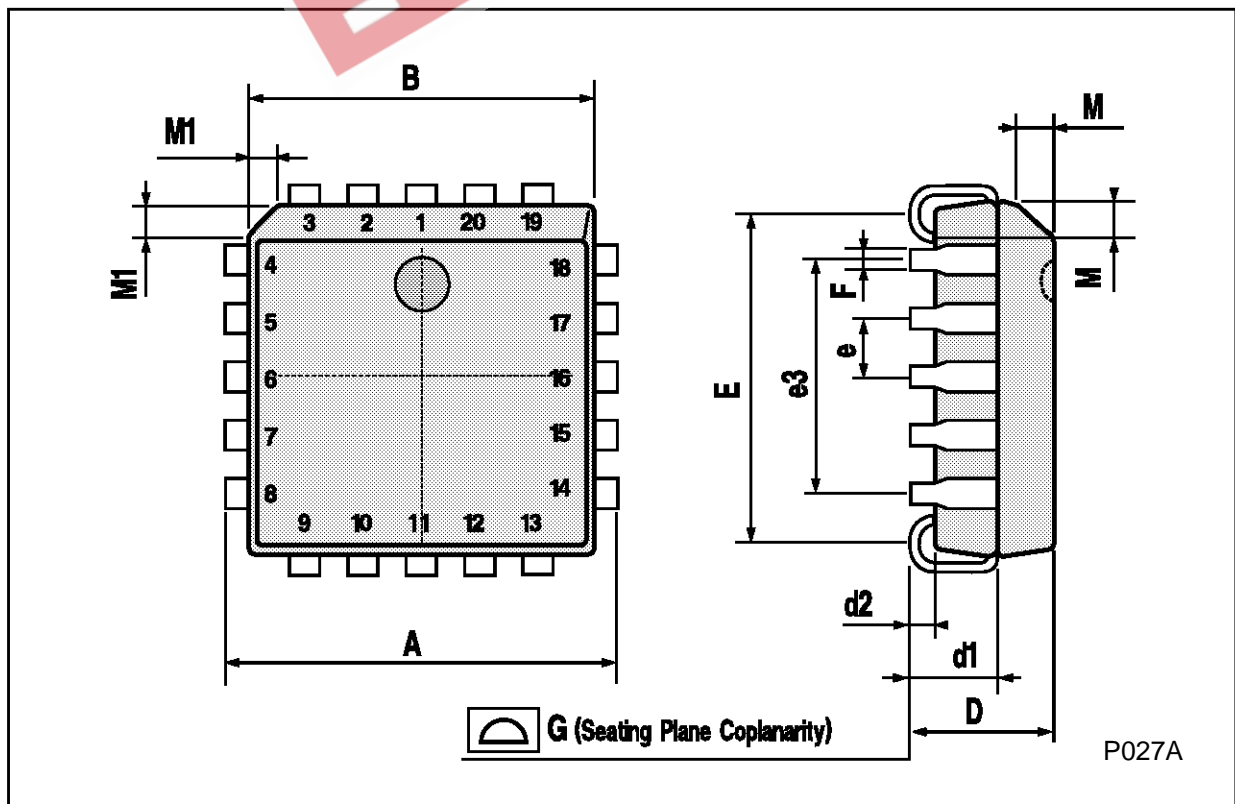

EEPW 电子產品世界
.com.cn

Information furnished is believed to be accurate and reliable. However, SGS-THOMSON Microelectronics assumes no responsibility for the consequences of use of such information nor for any infringement of patents or other rights of third parties which may result from its use. No license is granted by implication or otherwise under any patent or patent rights of SGS-THOMSON Microelectronics. Specifications mentioned in this publication are subject to change without notice. This publication supersedes and replaces all information previously supplied. SGS-THOMSON Microelectronics products are not authorized for use as critical components in life support devices or systems without express written approval of SGS-THOMSON Microelectronics.

© 1994 SGS-THOMSON Microelectronics - All Rights Reserved

SGS-THOMSON Microelectronics GROUP OF COMPANIES

Australia - Brazil - France - Germany - Hong Kong - Italy - Japan - Korea - Malaysia - Malta - Morocco - The Netherlands -
Singapore - Spain - Sweden - Switzerland - Taiwan - Thailand - United Kingdom - U.S.A