

ANALOG MULTIPLEXER/DEMULTIPLEXER WITH ADDRESS LATCH: SINGLE 8 CHANNEL, DUAL 4 CHANNEL, TRIPLE 2 CHANNEL

- LOGIC LEVEL TRANSLATION TO ENABLE 5V LOGIC SIGNAL TO COMMUNICATE WITH $\pm 5V$ ANALOG SIGNAL
- WIDE OPERATING VOLTAGE RANGE ($V_{CC} - V_{EE}$) 2V TO 12V
- LOW "ON" RESISTANCE:
70 Ω TYP. ($V_{CC} - V_{EE} = 4.5V$)
50 Ω TYP. ($V_{CC} - V_{EE} = 9V$)
- WIDE ANALOG INPUT VOLTAGE RANGE: $\pm 6V$
- FAST SWITCHING
- LOW CROSSTALK BETWEEN SWITCHES
- HIGH ON/OFF OUTPUT VOLTAGE RATIO
- LOW SINE WAVE DISTORTION:
0.02% (TYP.) AT $V_{CC} - V_{EE} = 9V$
- HIGH NOISE IMMUNITY
 $V_{NIH} = V_{NIL} = 28\% V_{CC}$ (MIN.)
- LOW POWER DISSIPATION
 $I_{CC} = 4 \mu A$ (MAX) AT $T_A = 25^\circ C$

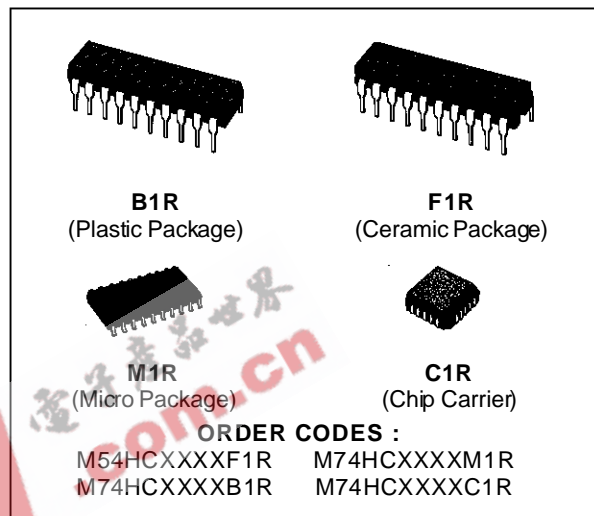

DESCRIPTION

These devices are analog multiplexer demultiplexers in high speed silicon gate C^2MOS technology. These analog switches are bidirectional and digitally controlled. A built-in level shifting is included to allow them a control input range of up to $\pm 6V$ (peak) for an analog signal with digital control signal of 0 to 6V.

V_{EE} supply pin is provided for analog input signals. They have two enable inputs to enable all the switches when high (EN2) or low ($\overline{EN1}$). For operation as a digital multiplexer/demultiplexer, V_{EE} is connected to GND.

The HC4351 is a single 8 channel multiplexer demultiplexer having three binary control inputs A, B and C to select 1 of 8 to be turned on, and connected to the output.

The HC4352 has a pair of four channel multiplexer demultiplexer having two control inputs A and B that select one of four channel of the two sections.

The HC4353 is a triple two channel multiplexer demultiplexer having three separate digital control inputs A, B and C to select independently one of a pair of channels.

PIN CONNECTION (top view)

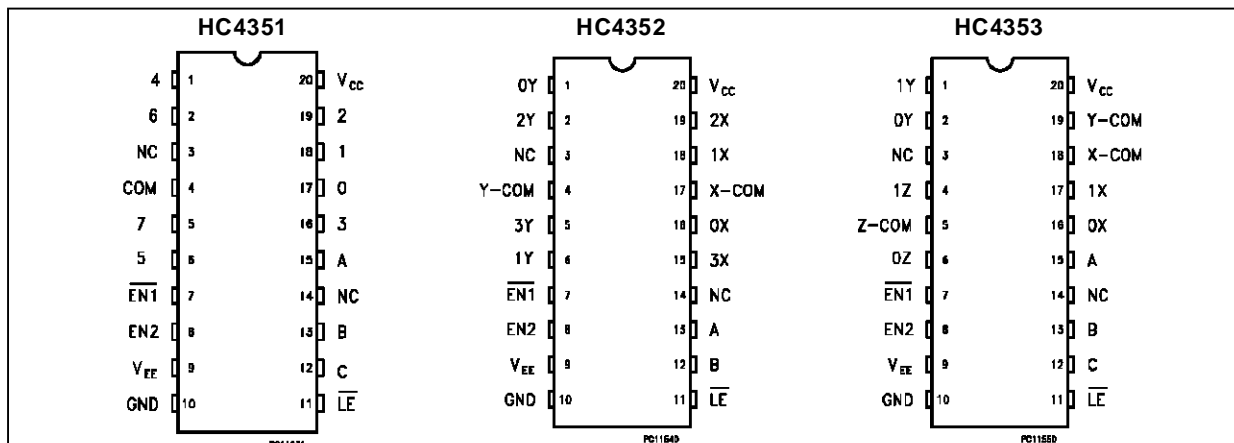

M54/M74HC4351/4352/4353

CHIP CARRIER

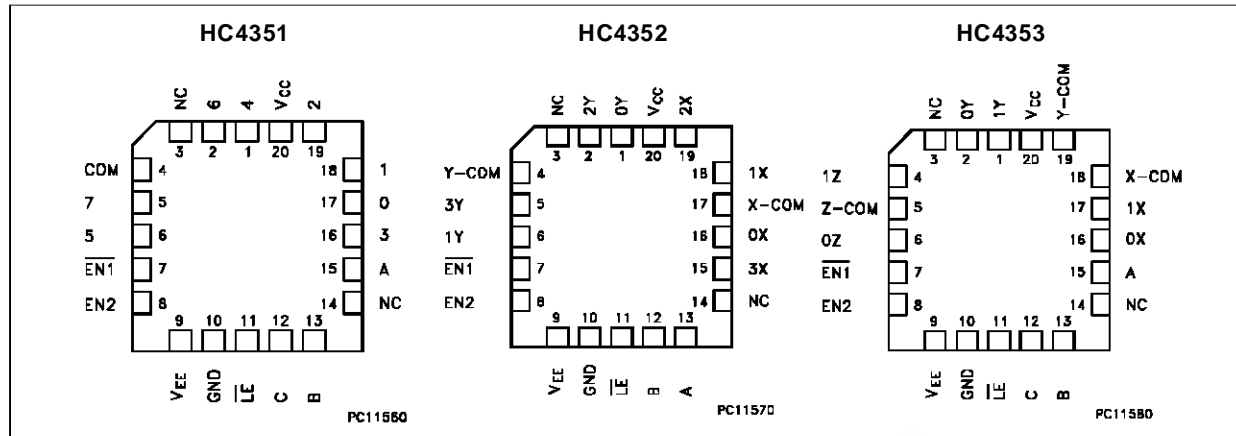

PIN DESCRIPTION (HC4351)

PIN No	SYMBOL	NAME AND FUNCTION
4	COM	Common
3, 14	NC	Not Connected
7	$\overline{\text{EN1}}$	Enable Input (Active LOW)
8	EN2	Enable Input (Active HIGH)
9	V_{EE}	Negative Supply Voltage
11	$\overline{\text{LE}}$	Latch Enable Input (Active LOW)
15, 13, 12	A, B, C	Select Inputs
17, 18, 19, 16, 1, 6, 2, 5	0 to 7	Independent Input/Outputs
10	GND	Ground (0V)
20	V_{CC}	Positive Supply Voltage

PIN DESCRIPTION (HC4352)

PIN No	SYMBOL	NAME AND FUNCTION
1, 6, 2, 5	0Y to 3Y	Independent Input/Outputs
3, 14	NC	Not Connected
7	$\overline{\text{EN1}}$	Enable Input (Active LOW)
8	EN2	Enable Input (Active HIGH)
9	V_{EE}	Negative Supply Voltage
11	$\overline{\text{LE}}$	Latch Enable Input (Active LOW)
13, 12	A, B	Select Inputs
16, 18, 19, 15	0X to 3X	Independent Input/Outputs
17, 4	X COM Y COM	Common Output/Inputs
10	GND	Ground (0V)
20	V_{CC}	Positive Supply Voltage

PIN DESCRIPTION (HC4353)

PIN No	SYMBOL	NAME AND FUNCTION
1, 2	0Y 1Y	Independent Input/Outputs
5	Z COM	Common Output/Inputs
6, 4	0Z, 1Z	Independent Input/Outputs
3, 14	NC	Not Connected
7	$\overline{\text{EN1}}$	Enable Input (Active LOW)
8	EN2	Enable Input (Active HIGH)
9	V_{EE}	Negative Supply Voltage
11	$\overline{\text{LE}}$	Latch Enable Input (Active LOW)
15, 13, 12	A, B, C	Select Inputs
16, 17	0X, 1X	Independent Input/Outputs
18	X COM	Common Output/Inputs
19	Y COM	Common Output/Inputs
10	GND	Ground (0V)
20	V_{CC}	Positive Supply Voltage

IEC LOGIC SYMBOLS

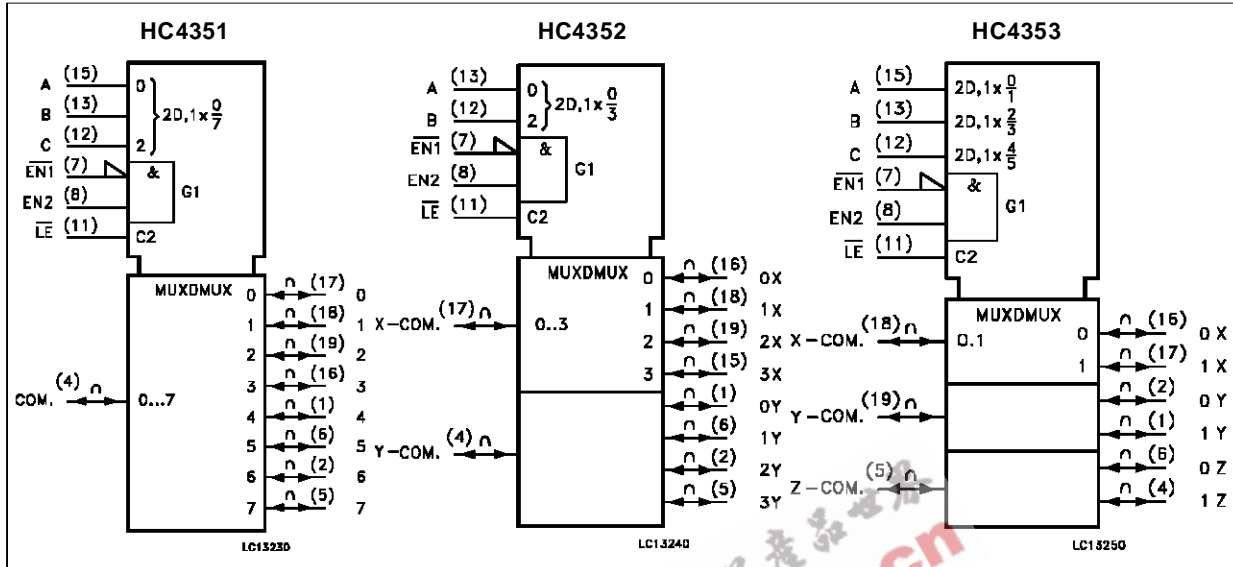

TRUTH TABLE

CONTROL INPUTS					"ON" CHANNEL (LE = H) **		
EN1	EN2	C *	B	A	HC4351	HC4352	HC4353
L	H	L	L	L	0	0X, 0Y	0X, 0Y, 0Z
L	H	L	L	H	1	1X, 1Y	1X, 0Y, 0Z
L	H	L	H	L	2	2X, 2Y	0X, 1Y, 0Z
L	H	L	H	H	3	3X, 3Y	1X, 1Y, 0Z
L	H	H	L	L	4	--	0X, 0Y, 1Z
L	H	H	L	H	5	--	1X, 0Y, 1Z
L	H	H	H	L	6	--	0X, 1Y, 1Z
L	H	H	H	H	7	--	1X, 1Y, 1Z
H	X	X	X	X	NONE	NONE	NONE
X	L	X	X	X	NONE	NONE	NONE

X: DON'T CARE *: HC4351/3 only

** When latch Enable is low, the Channel Selection is latched and the Channel Address Latch does not change state.

M54/M74HC4351/4352/4353

ABSOLUTE MAXIMUM RATINGS

Symbol	Parameter	Value	Unit
V_{CC}	Supply Voltage Range	-0.5 to +7	V
$V_{CC} - V_{EE}$	Supply Voltage Range	-0.5 to 13	V
V_{IN}	DC Input Voltage	-0.5 to $V_{CC} + 0.5$	V
$V_{I/O}$	DC Switch I/O Voltage	$V_{EE} - 0.5$ to $V_{CC} + 0.5$	V
I_{IK}	Input Diode Current	± 20	mA
I_{OK}	I/O Diode Current	± 20	mA
I_{OUT}	DC Output Current	± 25	mA
I_{CC} or I_{GND}	DC V_{CC} or Ground Current	± 50	mA
P_D	Power Dissipation	500 (*)	mW
T_{stg}	Storage Temperature	-65 to +150	°C
T_L	Lead Temperature (10 sec)	300	°C

Absolute Maximum Ratings are those values beyond which damage to the device may occur. Functional operation under these condition is not implied.

(*) 500 mW: $\cong 65$ °C derate to 300 mW by 10mW/°C: 65 °C to 85 °C

RECOMMENDED OPERATING CONDITIONS

Symbol	Parameter	Value	Unit
V_{CC}	Supply Voltage	2 to 6	V
V_{EE}	Supply Voltage	-6 to 0	V
$V_{CC} - V_{EE}$	Supply Voltage	2 to 12	V
V_{IN}	Input Voltage	0 to V_{CC}	V
$V_{I/O}$	DC Switch I/O Voltage	V_{EE} to V_{CC}	V
T_{op}	Operating Temperature:		
	M54HC Series	-55 to +125	°C
	M74HC Series	-40 to +85	°C
t_r, t_f	Input Rise and Fall Time		
	$V_{CC} = 2$ V	0 to 1000	ns
	$V_{CC} = 4.5$ V	0 to 500	
	$V_{CC} = 6$ V	0 to 400	

DC SPECIFICATIONS

Symbol	Parameter	Test Conditions			Value						Unit	
		V _{CC} (V)	V _{EE} (V)		T _A = 25 °C 54HC and 74HC			-40 to 85 °C 74HC		-55 to 125 °C 54HC		
					Min.	Typ.	Max.	Min.	Max.	Min.		Max.
V _{IHC}	High Level Control Input Voltage	2.0			1.5			1.5		1.5		V
		4.5			3.15			3.15		3.15		
		6.0			4.2			4.2		4.2		
V _{ILC}	Low Level Control Input Voltage	2.0					0.5		0.5		0.5	V
		4.5					1.35		1.35		1.35	
		6.0					1.8		1.8		1.8	
R _{ON}	ON Resistance	4.5	GND	V _{IN} = V _{IHC} or V _{ILC} V _{I/O} = V _{CC} to V _{EE} I _{I/O} ≤ 2 mA		85	180		225			Ω
		4.5	-4.5			55	120		150			
		6.0	-6.0			50	100		125			
		2.0	GND	V _{IN} = V _{IHC} or V _{ILC} V _{I/O} = V _{CC} or V _{EE} I _{I/O} ≤ 2 mA		150						
		4.5	GND			70	150		190			
		4.5	-4.5			50	100		125			
		6.0	-6.0			45	80		100			
ΔR _{ON}	Difference of ON Resistance Between Switches	4.5	GND	V _{IN} = V _{IHC} or V _{ILC} V _{I/O} = V _{CC} to V _{EE} I _{I/O} ≤ 2 mA		10	30		35			Ω
		4.5	-4.5			5	12		15			
		6.0	-6.0			5	10		12			
I _{OFF}	Input/Output Leakage Current (SWITCH OFF)	6.0	-6.0	V _{OS} = V _{CC} or GND V _{IS} = GND or V _{CC} V _{IN} = V _{ILC}			±100		±1000		±	nA
I _{Iz}	Switch Input Leakage Current (SWITCH ON)	6.0	-6.0	V _{OS} = V _{CC} or GND V _{INH} = V _{IHC}			±100		±1000		±	nA
I _{IN}	Control Input Current	6.0	GND	V _{IN} = V _{CC} or GND			±0.1		±1		±1	μA
I _{CC}	Quiescent Supply Current	6.0	GND	V _{IN} = V _{CC} or GND			4		40		80	μA
		6.0	-6.0				8		80		160	

M54/M74HC4351/4352/4353

AC ELECTRICAL CHARACTERISTICS for HC4351 ($C_L = 50 \text{ pF}$, Input $t_r = t_f = 6 \text{ ns}$, GND=0V)

Symbol	Parameter	Test Conditions			Value						Unit	
		V _{CC} (V)	V _{EE} (V)	R _L	T _A = 25 °C 54HC and 74HC			-40 to 85 °C 74HC		-55 to 125 °C 54HC		
					Min.	Typ.	Max.	Min.	Max.	Min.		Max.
Φ _{I/O}	Phase Difference Between Input and Output	2.0	GND			25	60		75			ns
		4.5	GND			6	12		15			
		6.0	GND			5	10		13			
		4.5	-4.5			4						
t _{PZL} t _{PHZ}	Output Enable Time (E1, E2 - O)	2.0	GND	R _L = 1KΩ		80	200		250		300	ns
		4.5	GND			20	40		50		60	
		6.0	GND			16	34		43		51	
		4.5	-4.5			18						
t _{PZL} t _{PHZ}	Output Enable Time (LE - I/O)	2.0	GND	R _L = 1KΩ		80	225		280		340	ns
		4.5	GND			22	45		56		68	
		6.0	GND			17	38		48		57	
		4.5	-4.5			18						
t _{PZL} t _{PHZ}	Output Enable Time (A, B, C - I/O)	2.0	GND	R _L = 1KΩ		75	225		280		340	ns
		4.5	GND			22	45		56		68	
		6.0	GND			16	38		48		57	
		4.5	-4.5			17						
t _{PLZ} t _{PHZ}	Output Disable Time (E1, E2 - O)	2.0	GND	R _L = 1KΩ		120	275		344		415	ns
		4.5	GND			38	55		69		83	
		6.0	GND			33	47		59		71	
		4.5	-4.5			30						
t _{PLZ} t _{PHZ}	Output Disable Time (LE - I/O)	2.0	GND	R _L = 1KΩ		120	275		344		415	ns
		4.5	GND			40	55		69		83	
		6.0	GND			35	47		59		71	
		4.5	-4.5			34						
t _{PLZ} t _{PHZ}	Output Disable Time (A, B, C - I/O)	2.0	GND	R _L = 1KΩ		120	290		363		433	ns
		4.5	GND			40	58		73		87	
		6.0	GND			35	49		61		74	
		4.5	-4.5			35						
t _{W(H)}	Minimum Pulse Width (LE)	2.0					75		95		110	ns
		4.5					15		19		22	
		6.0					13		16		19	
t _s	Minimum Set Up Time	2.0					50		60		75	ns
		4.5					10		12		15	
		6.0					9		11		13	
t _h	Minimum Hold Time	2.0					5		5		5	ns
		4.5					5		5		5	
		6.0					5		5		5	
C _{IN}	Input Capacitance					5	10		10		10	pF
C _{IS}	Common Terminal Capacitance	5.0	-5.0			36	70		70		70	pF
C _{OS}	Switch Terminal Capacitance	5.0	-5.0			7	15		15		15	pF
C _{IOS}	Feed Through Capacitance	5.0	-5.0			0.95	2		2		2	pF
C _{PD} (*)	Power Dissipation Capacitance	5.0	GND			23						pF

(*) C_{PD} is defined as the value of the IC's internal equivalent capacitance which is calculated from the operating current consumption without load. (Refer to Test Circuit). Average operating current can be obtained by the following equation. $I_{CC(OPR)} = C_{PD} \cdot V_{CC} \cdot f_{IN} + I_{CC}$

AC ELECTRICAL CHARACTERISTICS for HC4352 ($C_L = 50$ pF, Input $t_r = t_f = 6$ ns, GND=0V)

Symbol	Parameter	Test Conditions			Value						Unit	
		V _{CC} (V)	V _{EE} (V)	R _L	T _A = 25 °C 54HC and 74HC			-40 to 85 °C 74HC		-55 to 125 °C 54HC		
					Min.	Typ.	Max.	Min.	Max.	Min.		Max.
Φ _{I/O}	Phase Difference Between Input and Output	2.0	GND			25	60		75			ns
		4.5	GND			6	12		15			
		6.0	GND			5	10		13			
		4.5	-4.5			4						
t _{PZL} t _{PZH}	Output Enable Time (E1, E2 - O)	2.0	GND	R _L = 1KΩ		80	200		250		300	ns
		4.5	GND			20	40		50		60	
		6.0	GND			16	34		43		51	
		4.5	-4.5			18						
t _{PZL} t _{PZH}	Output Enable Time (LE - I/O)	2.0	GND	R _L = 1KΩ		80	225		280		340	ns
		4.5	GND			22	45		56		68	
		6.0	GND			17	38		48		57	
		4.5	-4.5			18						
t _{PZL} t _{PZH}	Output Enable Time (A, B, C - I/O)	2.0	GND	R _L = 1KΩ		80	225		280		340	ns
		4.5	GND			22	45		56		68	
		6.0	GND			16	38		48		57	
		4.5	-4.5			17						
t _{PLZ} t _{PHZ}	Output Disable Time (E1, E2 - O)	2.0	GND	R _L = 1KΩ		120	275		344		415	ns
		4.5	GND			38	55		69		83	
		6.0	GND			33	47		59		71	
		4.5	-4.5			36						
t _{PLZ} t _{PHZ}	Output Disable Time (LE - I/O)	2.0	GND	R _L = 1KΩ		160	275		344		415	ns
		4.5	GND			40	55		69		83	
		6.0	GND			34	47		59		71	
		4.5	-4.5			32						
t _{PLZ} t _{PHZ}	Output Disable Time (A, B, C - I/O)	2.0	GND	R _L = 1KΩ		120	275		344		415	ns
		4.5	GND			40	55		69		83	
		6.0	GND			35	47		59		71	
		4.5	-4.5			31						
t _{W(H)}	Minimum Pulse Width (LE)	2.0					75		95		110	ns
		4.5					15		19		22	
		6.0					13		16		19	
t _s	Minimum Set Up Time	2.0					50		60		75	ns
		4.5					10		12		15	
		6.0					9		11		13	
t _h	Minimum Hold Time	2.0					5		5		5	ns
		4.5					5		5		5	
		6.0					5		5		5	
C _{IN}	Input Capacitance					5	10		10		10	pF
C _{IS}	Common Terminal Capacitance	5.0	-5.0			19	40		40		40	pF
C _{OS}	Switch Terminal Capacitance	5.0	-5.0			7	15		15		15	pF
C _{IOS}	Feed Through Capacitance	5.0	-5.0			0.85	2		2		2	pF
C _{PD} (*)	Power Dissipation Capacitance	5.0	GND			34						pF

(*) C_{PD} is defined as the value of the IC's internal equivalent capacitance which is calculated from the operating current consumption without load. (Refer to Test Circuit). Average operating current can be obtained by the following equation. $I_{CC(opr)} = C_{PD} \cdot V_{CC} \cdot f_{IN} + I_{CC}$

M54/M74HC4351/4352/4353

AC ELECTRICAL CHARACTERISTICS for HC4353 ($C_L = 50 \text{ pF}$, Input $t_r = t_f = 6 \text{ ns}$, GND=0V)

Symbol	Parameter	Test Conditions			Value						Unit	
		V_{CC} (V)	V_{EE} (V)	R_L	$T_A = 25 \text{ }^\circ\text{C}$ 54HC and 74HC			$-40 \text{ to } 85 \text{ }^\circ\text{C}$ 74HC		$-55 \text{ to } 125 \text{ }^\circ\text{C}$ 54HC		
					Min.	Typ.	Max.	Min.	Max.	Min.		Max.
$\Phi_{I/O}$	Phase Difference Between Input and Output	2.0	GND			25	60		75			ns
		4.5	GND			6	12		15			
		6.0	GND			5	10		13			
		4.5	-4.5			4						
t_{PZL} t_{PZH}	Output Enable Time (E1, E2 - O)	2.0	GND	$R_L = 1K\Omega$		100	200		250		300	ns
		4.5	GND			22	40		50		60	
		6.0	GND			18	34		43		51	
		4.5	-4.5			19						
t_{PZL} t_{PZH}	Output Enable Time (LE - I/O)	2.0	GND	$R_L = 1K\Omega$		110	225		280		340	ns
		4.5	GND			24	45		56		68	
		6.0	GND			20	38		48		57	
		4.5	-4.5			18						
t_{PZL} t_{PZH}	Output Enable Time (A, B, C - I/O)	2.0	GND	$R_L = 1K\Omega$		100	225		280		340	ns
		4.5	GND			22	45		56		68	
		6.0	GND			18	38		48		57	
		4.5	-4.5			19						
t_{PLZ} t_{PHZ}	Output Disable Time (E1, E2 - O)	2.0	GND	$R_L = 1K\Omega$		130	290		363		435	ns
		4.5	GND			38	58		72		87	
		6.0	GND			32	49		61		74	
		4.5	-4.5			30						
t_{PLZ} t_{PHZ}	Output Disable Time (LE - I/O)	2.0	GND	$R_L = 1K\Omega$		140	300		375		450	ns
		4.5	GND			41	60		75		90	
		6.0	GND			34	51		64		77	
		4.5	-4.5			37						
t_{PLZ} t_{PHZ}	Output Disable Time (A, B, C - I/O)	2.0	GND	$R_L = 1K\Omega$		135	325		406			ns
		4.5	GND			42	65		81		100	
		6.0	GND			32	55		69		85	
		4.5	-4.5			35						
$t_{W(H)}$	Minimum Pulse Width (LE)	2.0					75		95		110	ns
		4.5					15		19		22	
		6.0						13		16		
t_s	Minimum Set Up Time	2.0					50		60		75	ns
		4.5					10		12		15	
		6.0					9		11		13	
t_h	Minimum Hold Time	2.0					5		5		5	ns
		4.5					5		5		5	
		6.0					5		5		5	
C_{IN}	Input Capacitance					5	10		10		10	pF
C_{IS}	Common Terminal Capacitance	5.0	-5.0			11	20		20		20	pF
C_{OS}	Switch Terminal Capacitance	5.0	-5.0			7	15		15		15	pF
C_{IOS}	Feed Through Capacitance	5.0	-5.0			0.75	2		2		2	pF
$C_{PD} (*)$	Power Dissipation Capacitance	5.0	GND			10						pF

(*) C_{PD} is defined as the value of the IC's internal equivalent capacitance which is calculated from the operating current consumption without load. (Refer to Test Circuit). Average operating current can be obtained by the following equation. $I_{CC(OPR)} = C_{PD} \cdot V_{CC} \cdot f_{IN} + I_{CC}$

ANALOG SWITCH CHARACTERISTICS (GND = 0 V T_A = 25 °C)

Symbol	Parameter	Test Conditions			Value	Unit	
		V _{CC} (V)	V _{EE} (V)	V _{IN} (Vp-p)			Typ.
	Sine Wave Distortion	2.25	-2.25	4	f _{IN} = 1 KHz R _L = 10 Ω C _L = 50 pF	%	
		4.5	-4.5	8			0.025
f _{MAX}	Frequency Response (Switch ON)	4.5	-4.5	Adjust f _{IN} voltage to Obtain 0 dBm at V _{OS} . Increase f _{IN} Frequency until dB Meter Reads -3dB R _L = 50 Ω C _L = 10 pF (*)		200	MHz
	Feedthrough Attenuation (Switch OFF)	2.25	-2.25	V _{IN} is centered at (V _{CC} - V _{EE})/2. Adjust input for 0 dBm R _L = 600 Ω C _L = 50 pF f _{IN} = 1 MHz sine wave		-50	dB
		4.5	-4.5			-50	
		6	-6			-50	
	Crosstalk Control to switch	2.25	-2.25	t _r = t _f = 6ns R _L = 600 Ω C _L = 50 pF f _{IN} = 1 MHz square wave		110	mV
		4.5	-4.5			225	
		6.0	-6.0			310	
	Crosstalk Between any two switches	2.25	-2.25	Adjust V _{IN} to obtain 0dBm at input R _L = 600 Ω C _L = 50 pF f _{IN} = 1 MHz sine wave		-50	dB
		4.5	-4.5			-50	
		6	-6			-50	

(*): Input COMMON Terminal, and measured at SWITCH Terminal.

NOTE: These characteristics are determined by design of devices.

SWITCHING CHARACTERISTICS TEST CIRCUIT

t_{PLZ} , t_{PHZ} , t_{PZL} , t_{PZH} .

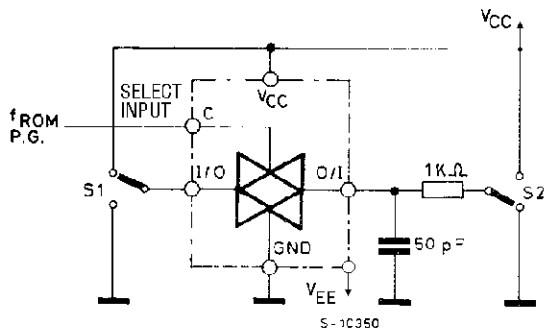

CROSSTALK (control to output)

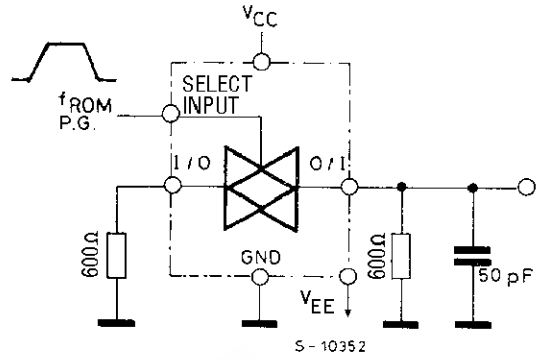

BANDWIDTH AND FEEDTHROUGH ATTENUATION

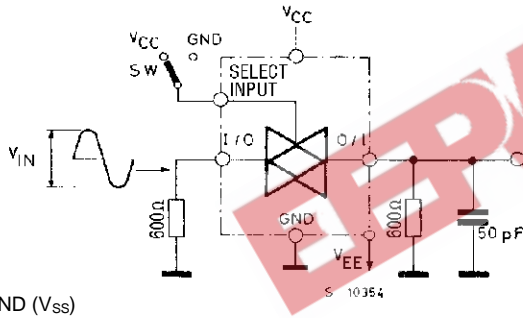

GND (V_{SS})

C_{I-O} $C_{I/O}$

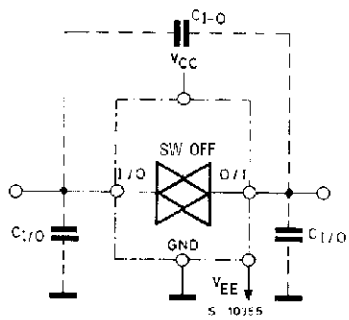

GND (V_{SS})

CROSSTALK BETWEEN ANY TWO SWITCHES

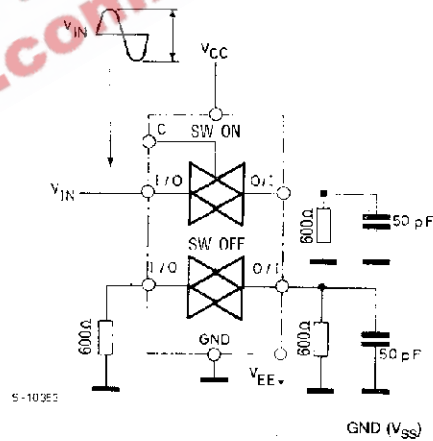

GND (V_{SS})

SWITCHING CHARACTERISTICS TEST WAVEFORM

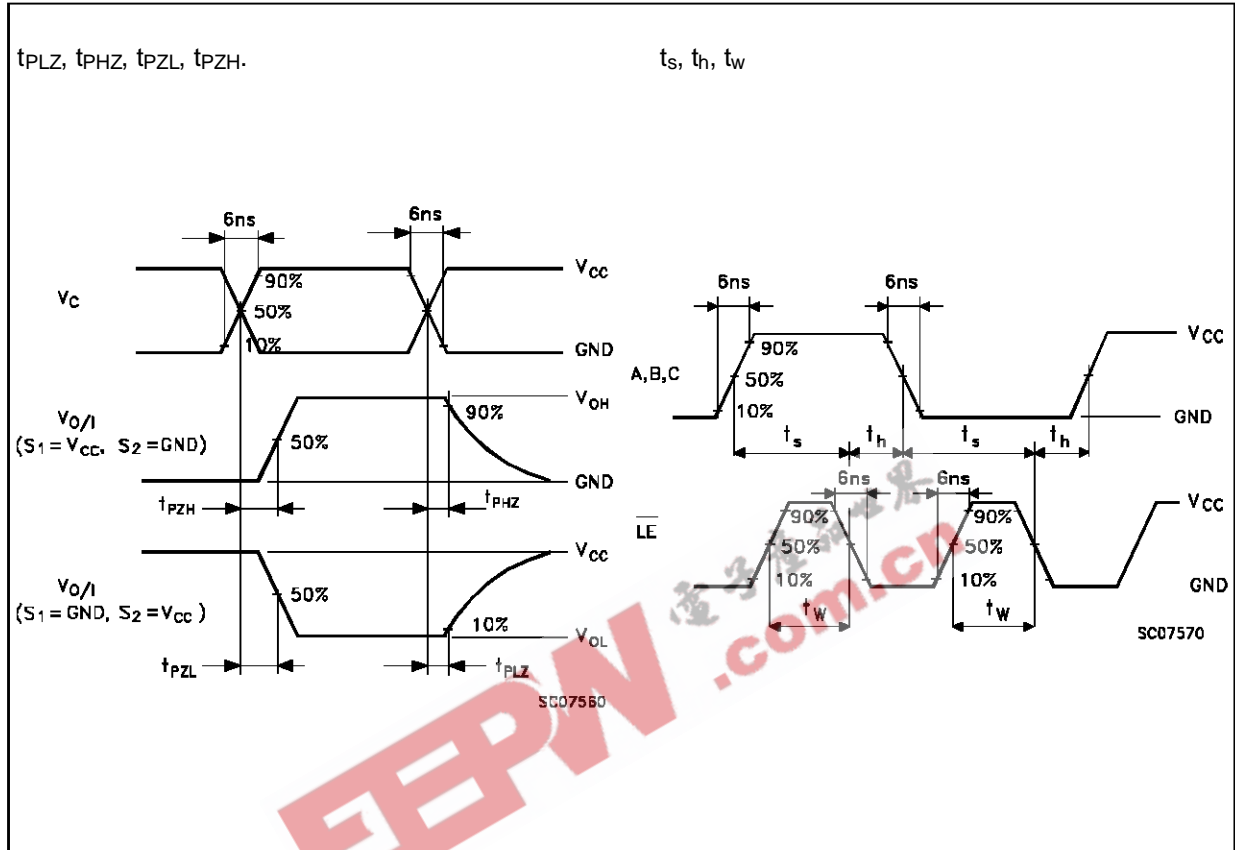

CHANNEL RESISTANCE (RON)

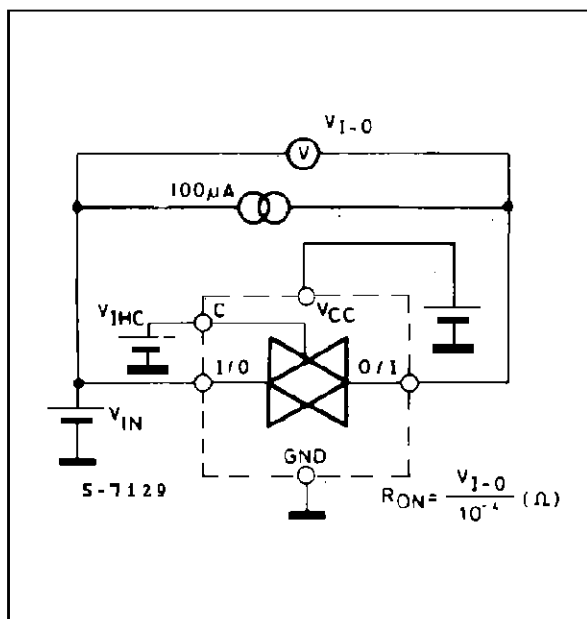

Icc (Opr.)

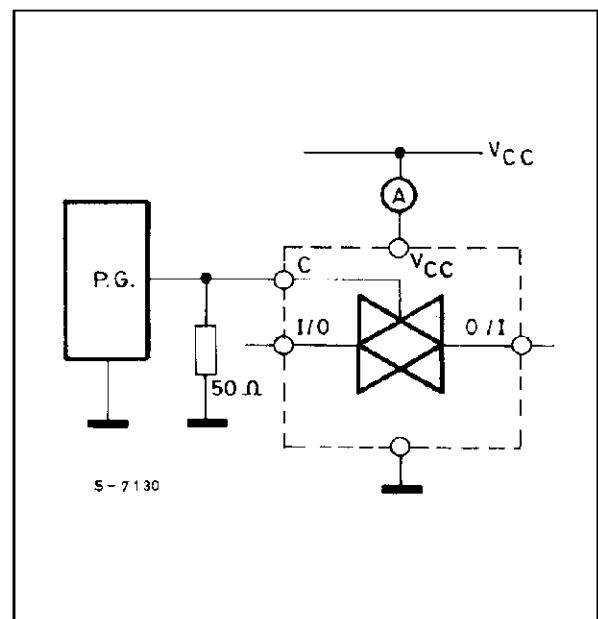

Plastic DIP20 (0.25) MECHANICAL DATA

DIM.	mm			inch		
	MIN.	TYP.	MAX.	MIN.	TYP.	MAX.
a1	0.254			0.010		
B	1.39		1.65	0.055		0.065
b		0.45			0.018	
b1		0.25			0.010	
D			25.4			1.000
E		8.5			0.335	
e		2.54			0.100	
e3		22.86			0.900	
F			7.1			0.280
I			3.93			0.155
L		3.3			0.130	
Z			1.34			0.053

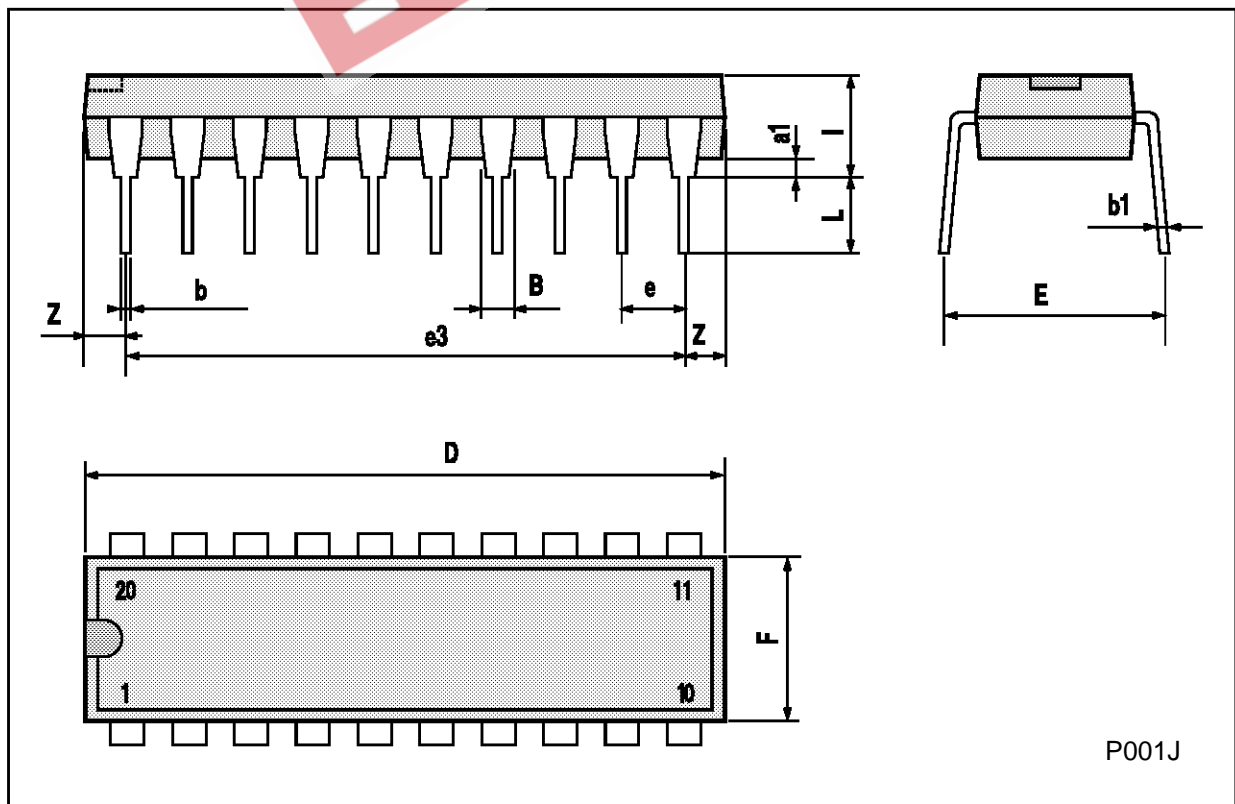

Ceramic DIP20 MECHANICAL DATA

DIM.	mm			inch		
	MIN.	TYP.	MAX.	MIN.	TYP.	MAX.
A			25			0.984
B			7.8			0.307
D		3.3			0.130	
E	0.5		1.78	0.020		0.070
e3		22.86			0.900	
F	2.29		2.79	0.090		0.110
G	0.4		0.55	0.016		0.022
I	1.27		1.52	0.050		0.060
L	0.22		0.31	0.009		0.012
M	0.51		1.27	0.020		0.050
N1	4° (min.), 15° (max.)					
P	7.9		8.13	0.311		0.320
Q			5.71			0.225

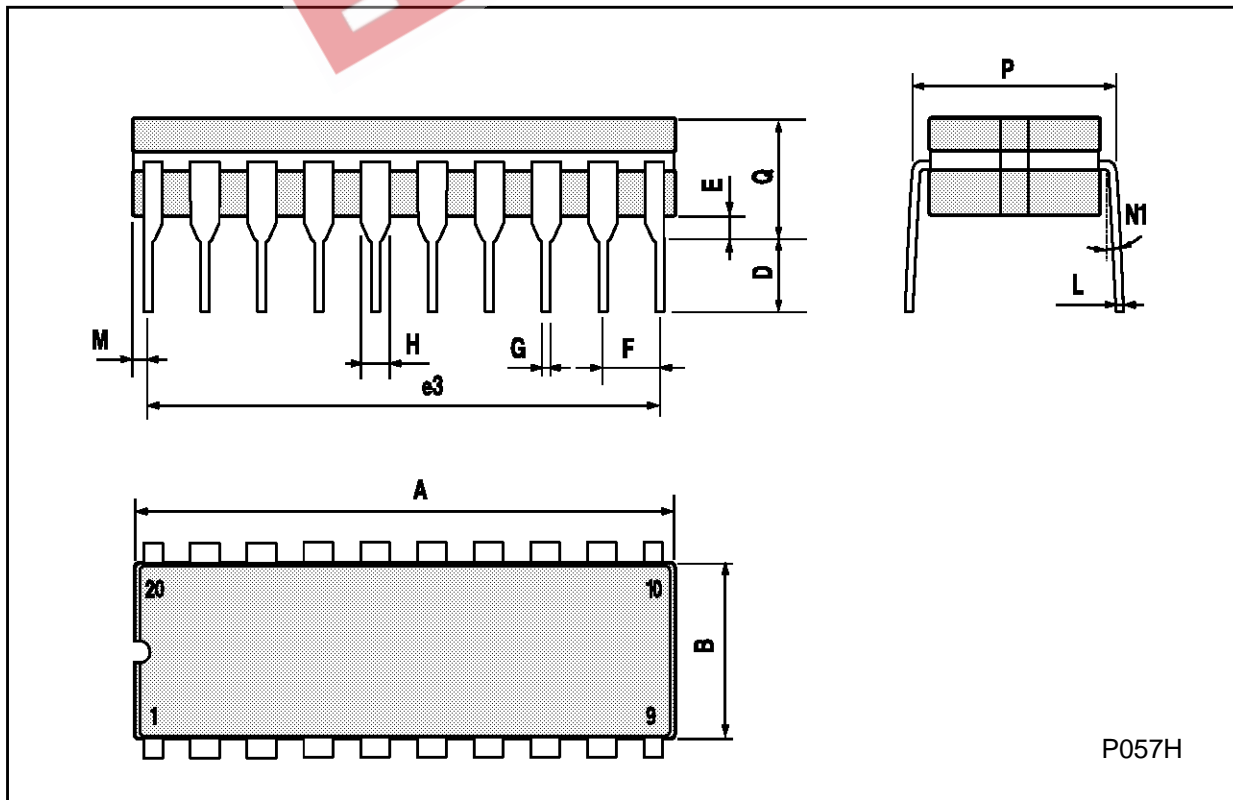

SO20 MECHANICAL DATA

DIM.	mm			inch		
	MIN.	TYP.	MAX.	MIN.	TYP.	MAX.
A			2.65			0.104
a1	0.10		0.20	0.004		0.007
a2			2.45			0.096
b	0.35		0.49	0.013		0.019
b1	0.23		0.32	0.009		0.012
C		0.50			0.020	
c1	45° (typ.)					
D	12.60		13.00	0.496		0.512
E	10.00		10.65	0.393		0.419
e		1.27			0.050	
e3		11.43			0.450	
F	7.40		7.60	0.291		0.299
L	0.50		1.27	0.19		0.050
M			0.75			0.029
S	8° (max.)					

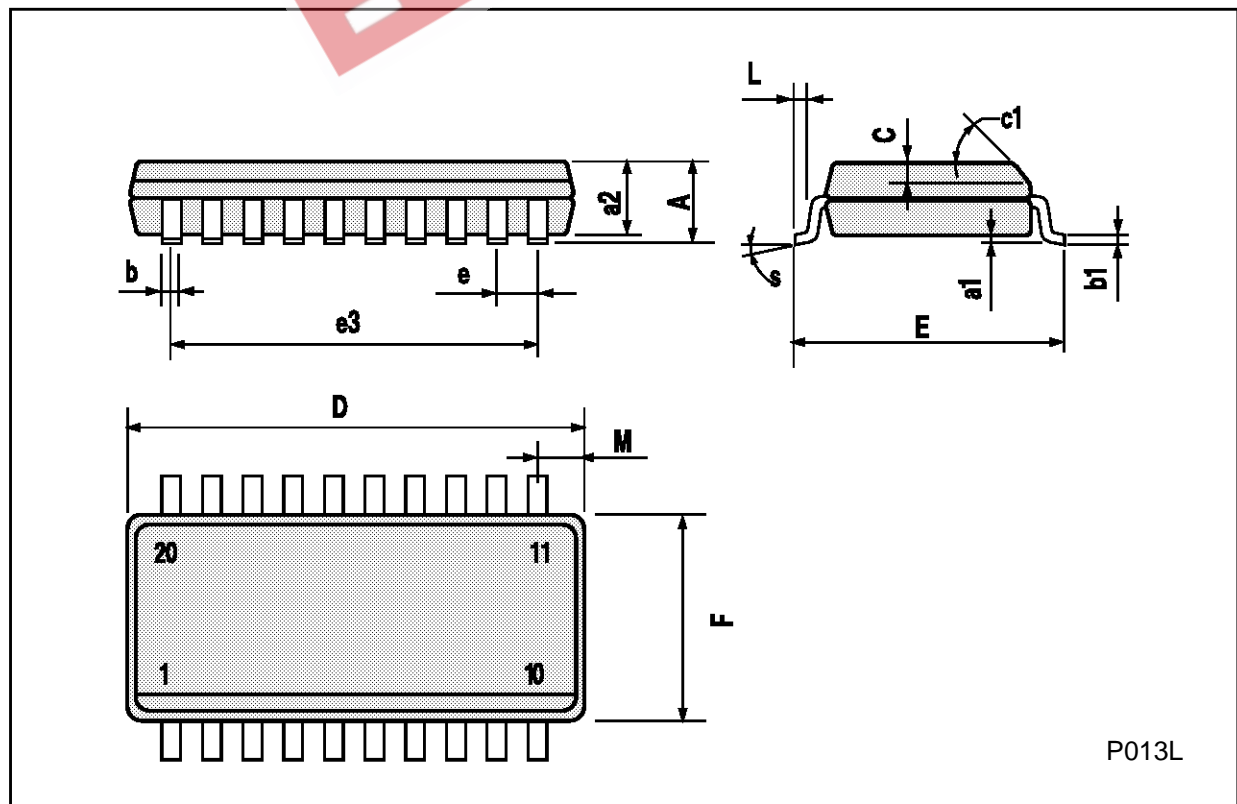

PLCC20 MECHANICAL DATA

DIM.	mm			inch		
	MIN.	TYP.	MAX.	MIN.	TYP.	MAX.
A	9.78		10.03	0.385		0.395
B	8.89		9.04	0.350		0.356
D	4.2		4.57	0.165		0.180
d1		2.54			0.100	
d2		0.56			0.022	
E	7.37		8.38	0.290		0.330
e		1.27			0.050	
e3		5.08			0.200	
F		0.38			0.015	
G			0.101			0.004
M		1.27			0.050	
M1		1.14			0.045	

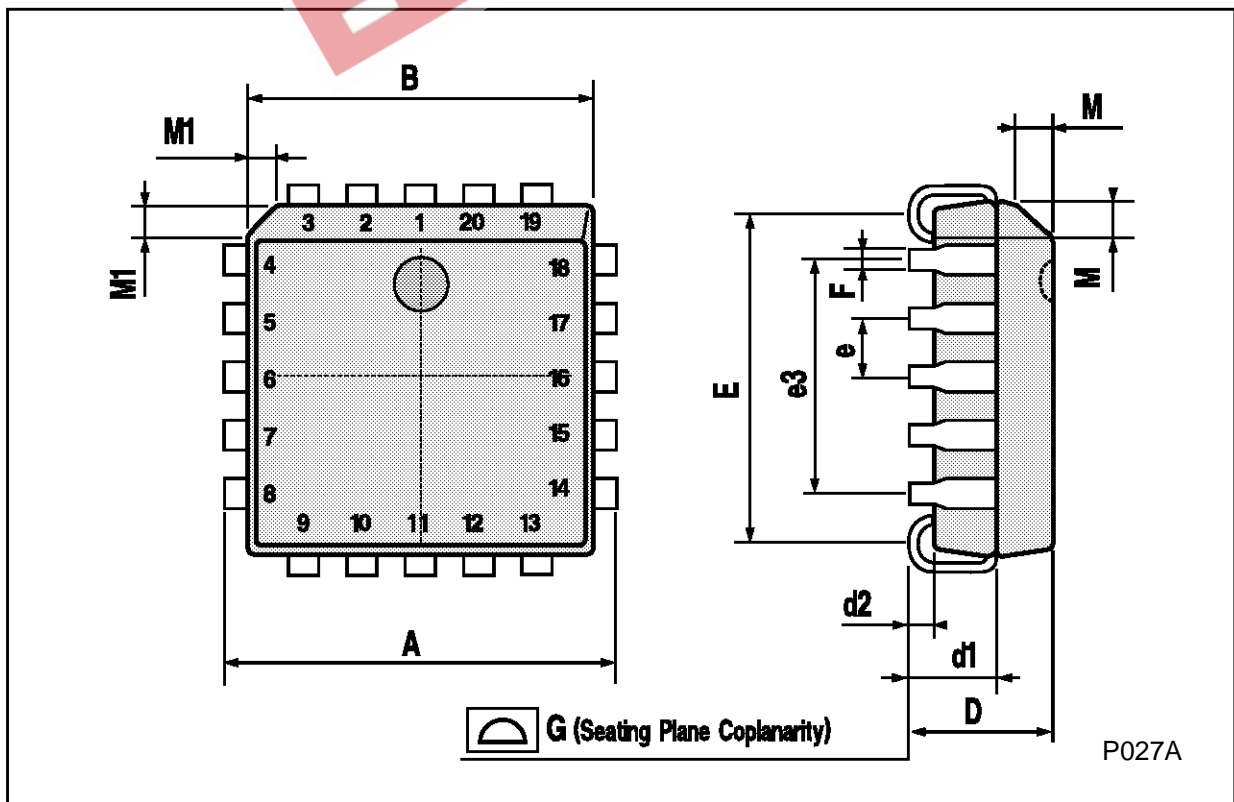

EEPW 电子產品世界
.com.cn

Information furnished is believed to be accurate and reliable. However, SGS-THOMSON Microelectronics assumes no responsibility for the consequences of use of such information nor for any infringement of patents or other rights of third parties which may result from its use. No license is granted by implication or otherwise under any patent or patent rights of SGS-THOMSON Microelectronics. Specifications mentioned in this publication are subject to change without notice. This publication supersedes and replaces all information previously supplied. SGS-THOMSON Microelectronics products are not authorized for use as critical components in life support devices or systems without express written approval of SGS-THOMSON Microelectronics.

© 1994 SGS-THOMSON Microelectronics - All Rights Reserved

SGS-THOMSON Microelectronics GROUP OF COMPANIES
Australia - Brazil - France - Germany - Hong Kong - Italy - Japan - Korea - Malaysia - Malta - Morocco - The Netherlands -
Singapore - Spain - Sweden - Switzerland - Taiwan - Thailand - United Kingdom - U.S.A