



DESCRIPTION

The MC34063A is a monolithic control circuit containing the primary functions required for DC-to-DC converters. The device consists of an internal temperature compensated reference, comparator, controlled duty cycle oscillator with an active current limit circuit, driver and high current output switch. MC34063A is specifically designed to be incorporated in Step-Down, Step-Up and Voltage-Inverting applications with a minimum number of external components.

FEATURES

- Operation from -0.3V to 40V Input
- Low Standby Current
- Current Limiting
- Output Switch Current to 1.5A
- Output Voltage Adjustable
- Frequency Operation to 42kHz
- Precision 2% Reference

APPLICATION

- DC-DC Converter

ORDERING INFORMATION

Temperature Range	Package		Orderable Device	Package Qty
0°C to +70°C	SOP8L	Pb-Free	MC34063ADG	75Units/Tube
	SOP8L		MC34063ADRG	2500Units/Tape
	DIP8L		MC34063APG	50Units/Tube

PIN CONFIGURATION

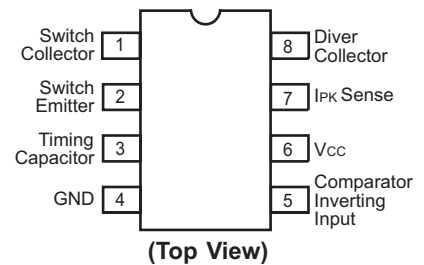

SCHEMATIC DIAGRAM

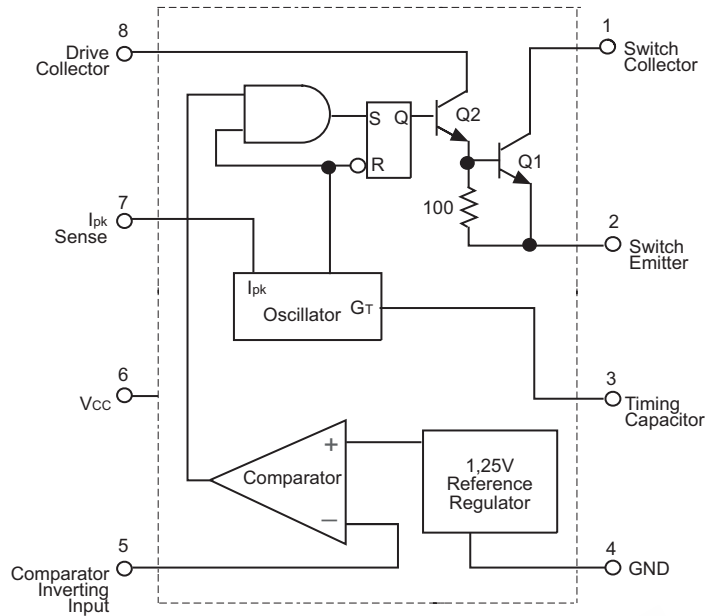

(Bottom View)

Figure 1. Representative Schematic Diagram

ABSOLUTE MAXIMUM RATINGS

Parameter	Symbol	Value	Unit
Power Supply Voltage	V_{CC}	40	V
Comparator Input Voltage Range	V_{IR}	-0.3 to +40	V
Switch Collector Voltage	$V_{C(\text{switch})}$	40	V
Switch Emitter Voltage ($V_{\text{Pin1}} = 40 \text{ V}$)	$V_{E(\text{switch})}$	40	V
Switch Collector to Emitter Voltage	$V_{CE(\text{switch})}$	40	V
Driver Collector Voltage	$V_{C(\text{driver})}$	40	V
Driver Collector Current (Note 1)	$I_{C(\text{driver})}$	100	mA
Switch Current	I_{SW}	1.5	A
Power Dissipation, $T_A = 25^\circ\text{C}$	D Package	P_D	625 mW
	P Package		1.25 W
Thermal Resistance, $T_A = 25^\circ\text{C}$	D Package	$R_{\theta JA}$	160 $^\circ\text{C/W}$
	P Package		100 $^\circ\text{C/W}$
Operating Junction Temperature	T_J	+150	$^\circ\text{C}$
Operating Ambient Temperature Range	T_A	0 to +70	$^\circ\text{C}$
Storage Temperature Range	T_{stg}	-65 to +150	$^\circ\text{C}$



ELECTRICAL CHARACTERISTICS

(V_{CC} = 5.0V, T_A=0 to +70°C, unless otherwise specified)

Parameter	Symbol	Test Conditions	Min	Typ	Max	Unit
OSCILLATOR						
Frequency	f _{osc}	V _{Pin5} =0V, C _T =1.0nF, T _A = 25°C	24	33	42	kHz
Charge Current	I _{chg}	V _{CC} = 5.0V to 40V, T _A = 25°C	24	33	42	μA
Discharge Current	I _{dischg}	V _{CC} = 5.0V to 40V, T _A = 25°C	140	200	260	μA
Discharge to Charge Current Ratio	I _{dischg} /I _{chg}	Pin7 to V _{CC} , T _A =25°C	5.2	6.2	7.5	
Current Limit Sense Voltage	V _{lpk(sense)}	I _{chg} = I _{dischg} , T _A = 25°C	250	300	350	mV
OUTPUT SWITCH (Note 3)						
Saturation Voltage, Darlington Connection	V _{CE(sat)}	I _{SW} = 1.0A, Pins 1, 8 connected		1.0	1.3	V
Saturation Voltage,	V _{CE(sat)}	I _{SW} = 1.0A, Forced β = 20 R _{Pin 8} = 82Ω to V _{CC}		0.45	0.7	V
DC Current Gain	h _{FE}	I _{SW} = 1.0A, V _{CE} =5.0V, T _A = 25°C	50	75		
Collector Off-State Current	I _{C(off)}	V _{CE} = 40V	40	100		μA
COMPARATOR						
Threshold Voltage	V _{th}	T _A = 25°C	1.225	1.25	1.275	V
		T _A = T _{low} to T _{high}	1.21		1.29	
Threshold Voltage Line Regulation	Reg _{line}	V _{CC} = 3.0V to 40V		1.4	5.0	mV
Input Bias Current	I _{IB}	V _{in} = 0V		-20	-400	nA
TOTAL DEVICE						
Supply Current	I _{CC}	V _{CC} = 5.0V to 40V, C _T = 10nF, V _{pin7} = V _{CC} , V _{Pin5} > V _{th} , Pin 2 = GND, Remaining pins open		2.5	4.0	mA

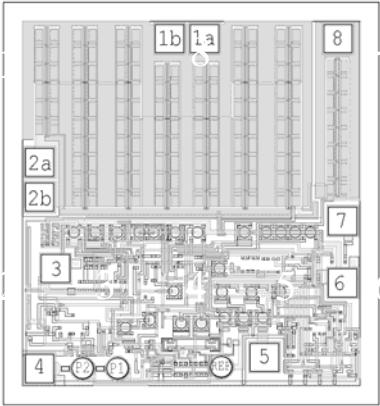
<p>CHIP APPEARANCE</p> 	CHIP SIZE		1,18 × 1,27 mm	
	CHIP THICKNESS		460 ± 20 μm	
	BONDING PAD DIMENSION	1a	SWITCH COLLECTOR	90 × 90 μm
		1b	SWITCH COLLECTOR	90 × 90 μm
		2a	SWITCH EMITTER	90 × 90 μm
		2b	SWITCH EMITTER	90 × 90 μm
		3	TIMING CAPACITOR	90 × 90 μm
		4	GROUND	90 × 90 μm
		5	COMPARATOR INVERTING INPUT	90 × 90 μm
		6	Vcc	90 × 90 μm
7	Ipk SENCE	90 × 90 μm		
8	DRIVER COLLECTOR	90 × 90 μm		
SCRIBE LINE WIDTH		96 μm		
TOP METAL		Al		
BACK METAL		-		
WAFER SIZE		100 mm		

TYPICAL PERFORMANCE CHARACTERISTICS

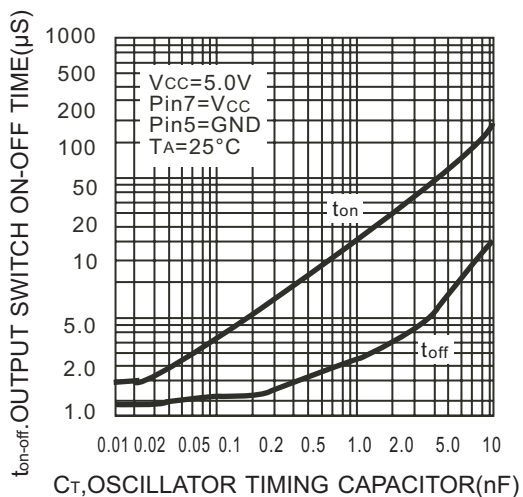

Figure 2. Output Switch On-Off Time vs. Oscillator Timing Capacitor

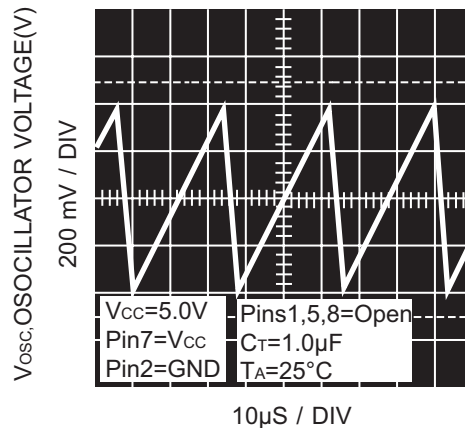

Figure 3. Timing Capacitor Waveform

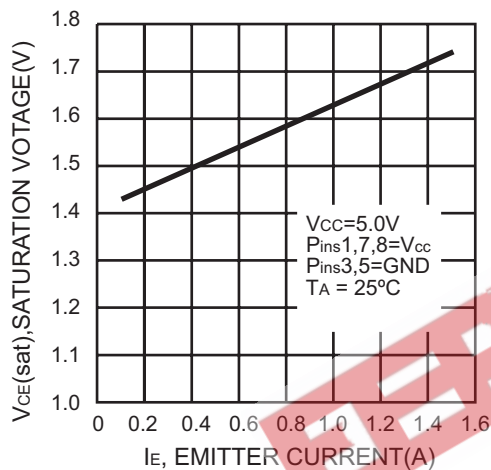

Figure 4. Emitter Follower Configuration Output Saturation Voltage vs. Emitter Current

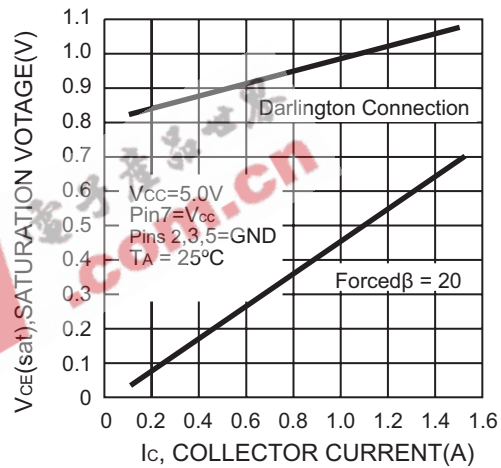

Figure 5. Common Emitter Configuration Output Switch Saturation Voltage vs. Collector Current

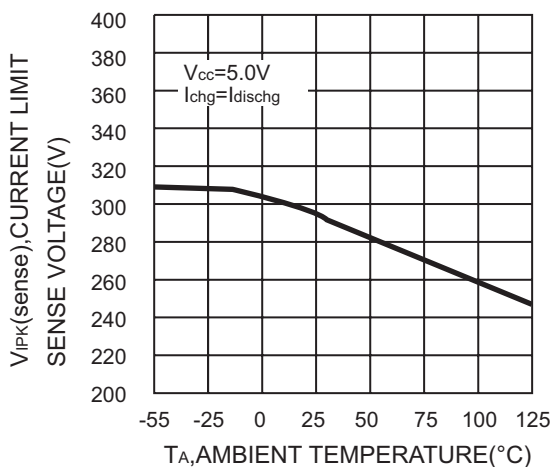

Figure 6. Current Limit Sense Voltage vs. Temperature

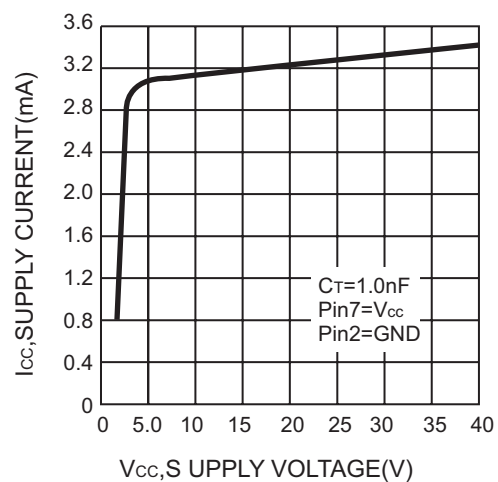

Figure 7. Standby Supply Current vs. Supply Voltage

TYPICAL APPLICATION

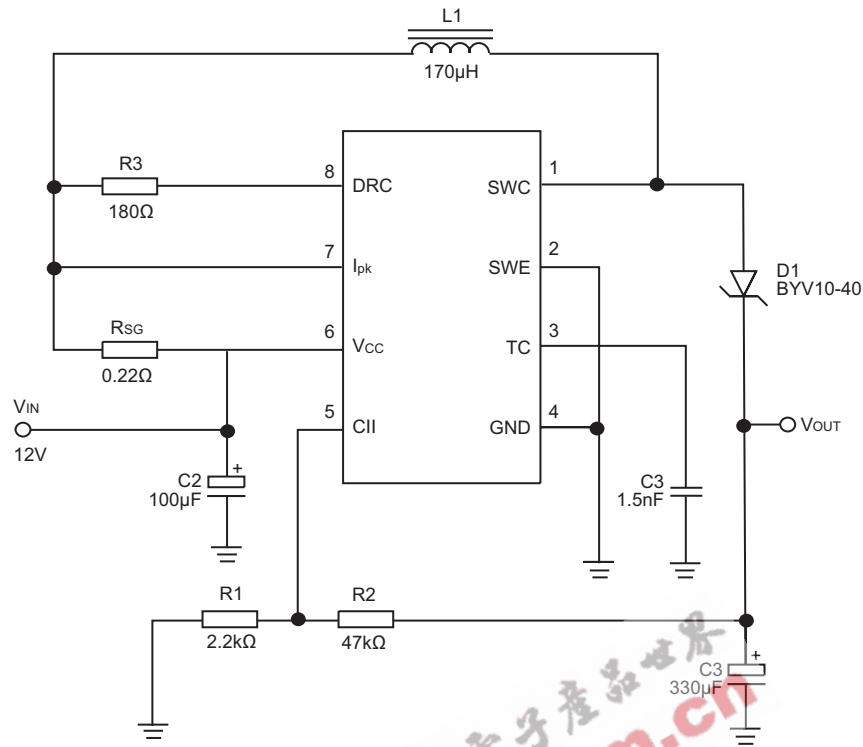

Figure 8. Step-Up Converter

For $V_{OUT}=28V$

Parameter	Test Conditions	Result(Typ)	Unit
Line Regulation	$V_{IN} = 8 \text{ to } 16 \text{ V}$, $I_o = 175 \text{ mA}$	30	mV
Load Regulation	$V_{IN} = 12 \text{ V}$, $I_o = 75 \text{ to } 175 \text{ mA}$	10	mV
Output Ripple	$V_{IN} = 12 \text{ V}$, $I_o = 175 \text{ mA}$	300	mV
Efficiency	$V_{IN} = 12 \text{ V}$, $I_o = 175 \text{ mA}$	89	%

TYPICAL APPLICATION(CONTINUED)

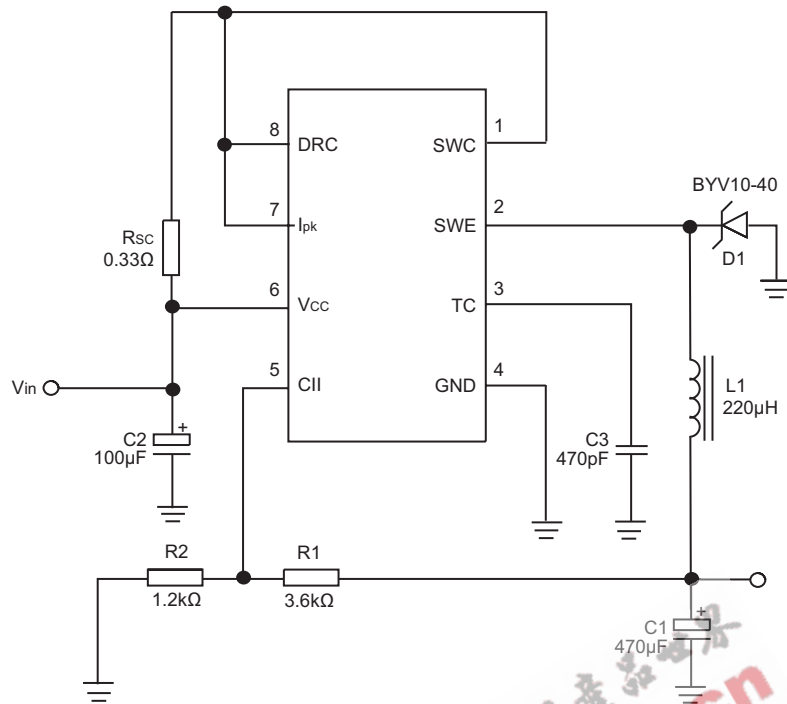

Figure 9. Step-Down Converter

For $V_{OUT} = 5V$

Parameter	Test Conditions	Result(Typ)	Unit
Line Regulation	$V_{IN} = 15$ to 25 V, $I_o = 500$ mA	5	mV
Load Regulation	$V_{IN} = 25$ V, $I_o = 50$ to 500 mA	30	mV
Output Ripple	$V_{IN} = 25$ V, $I_o = 500$ mA	100	mV
Efficiency	$V_{IN} = 25$ V, $I_o = 500$ mA	80	%
I_{sc}	$V_{IN} = 25$ V, $R_{load} = 0.1$ Ω	1.2	A

TYPICAL APPLICATION(CONTINUED)

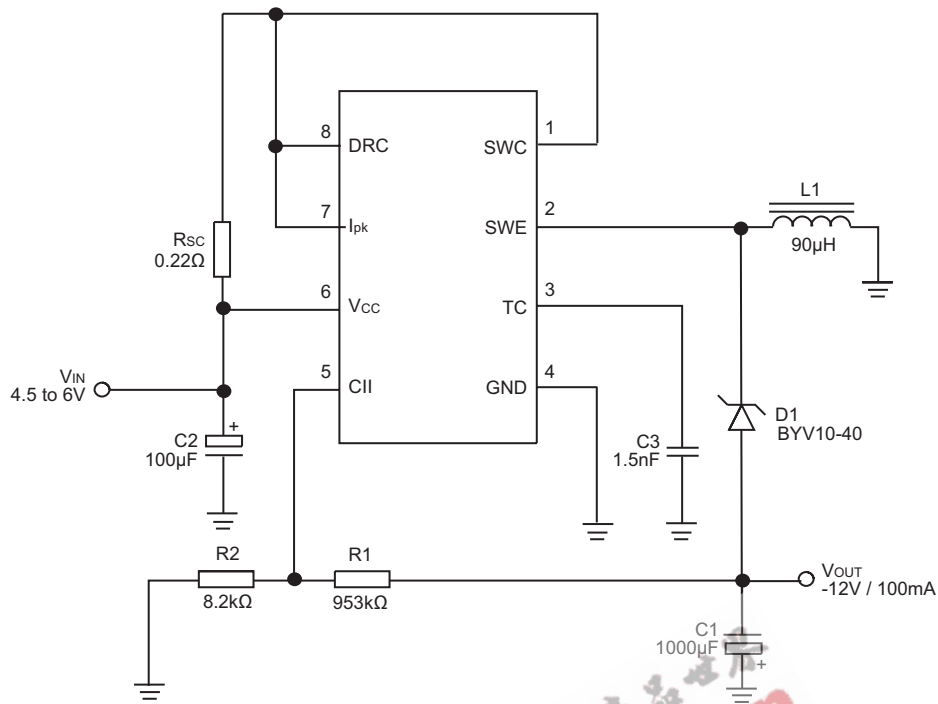

Figure 10. Voltage Inverting Converter

For $V_{OUT} = -12V$

Parameter	Test Conditions	Result(Typ)	Unit
Line Regulation	$V_{IN} = 4.5 \text{ to } 6 \text{ V}$, $I_o = 100 \text{ mA}$	15	mV
Load Regulation	$V_{IN} = 5 \text{ V}$, $I_o = 10 \text{ to } 100\text{mA}$	20	mV
Output Ripple	$V_{IN} = 5 \text{ V}$, $I_o = 100 \text{ mA}$	230	mV
Efficiency	$V_{IN} = 5 \text{ V}$, $I_o = 100\text{mA}$	58	%
I_{sc}	$V_{IN} = 5 \text{ V}$, $R_{load} = 0.1 \Omega$	0.9	A

TYPICAL APPLICATION(CONTINUED)

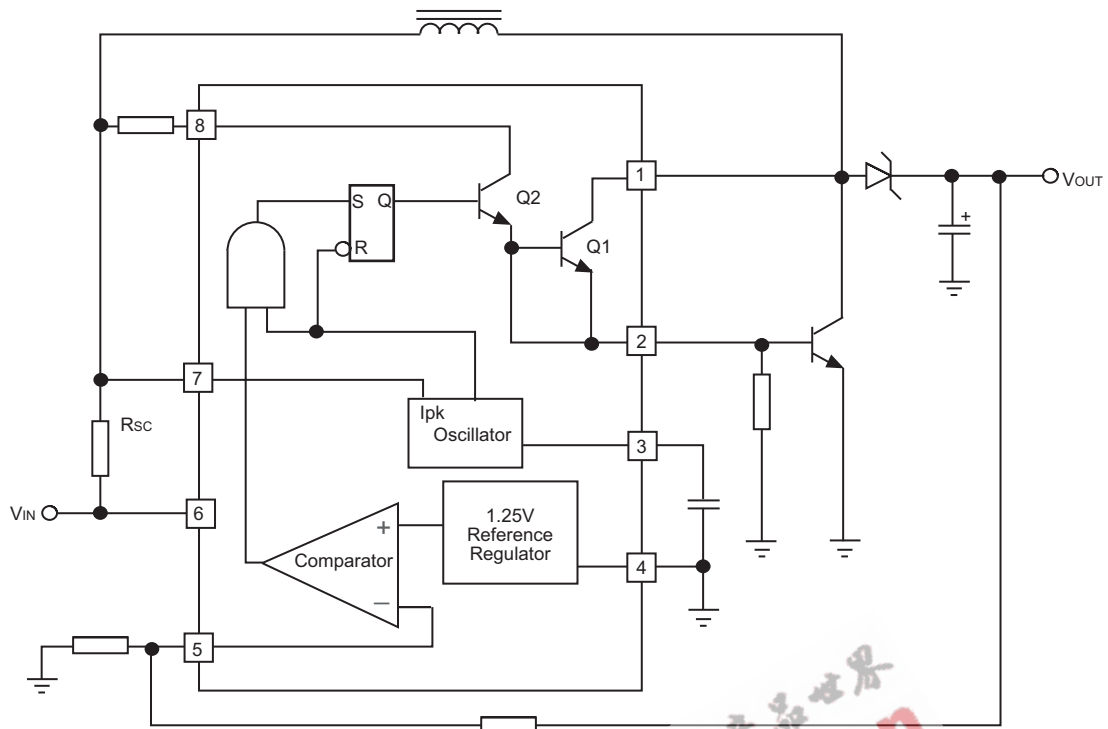

Figure 11. Step-up with External NPN Switch

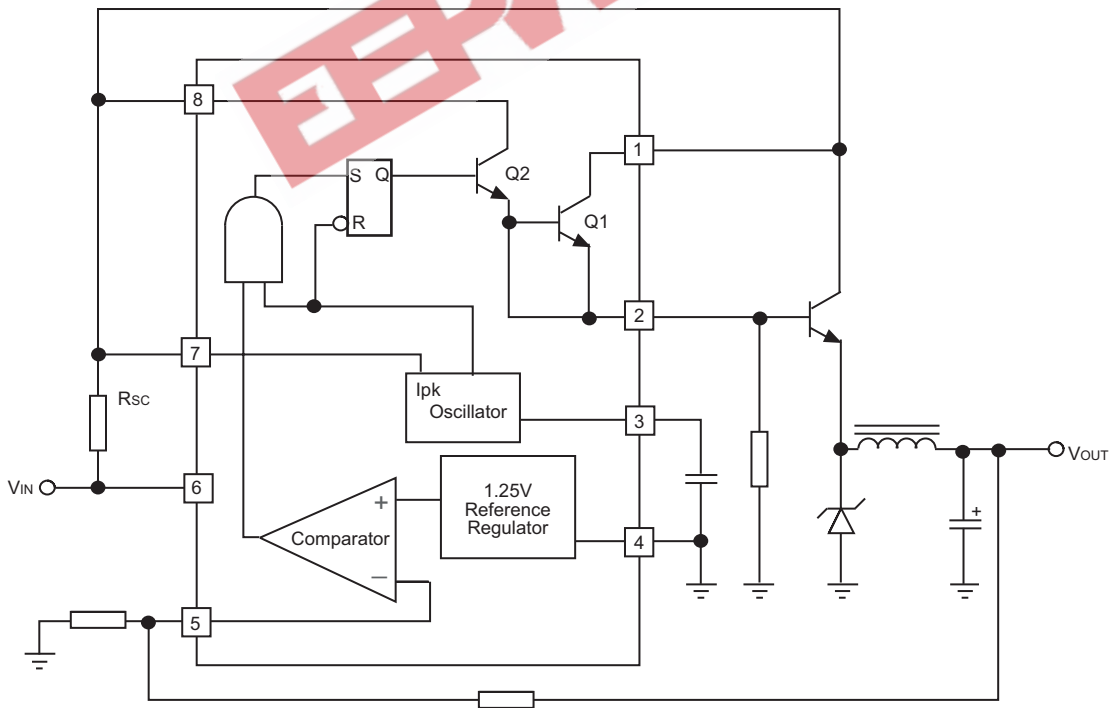

Figure 12. Step-down with External NPN Switch

TYPICAL APPLICATION(CONTINUED)

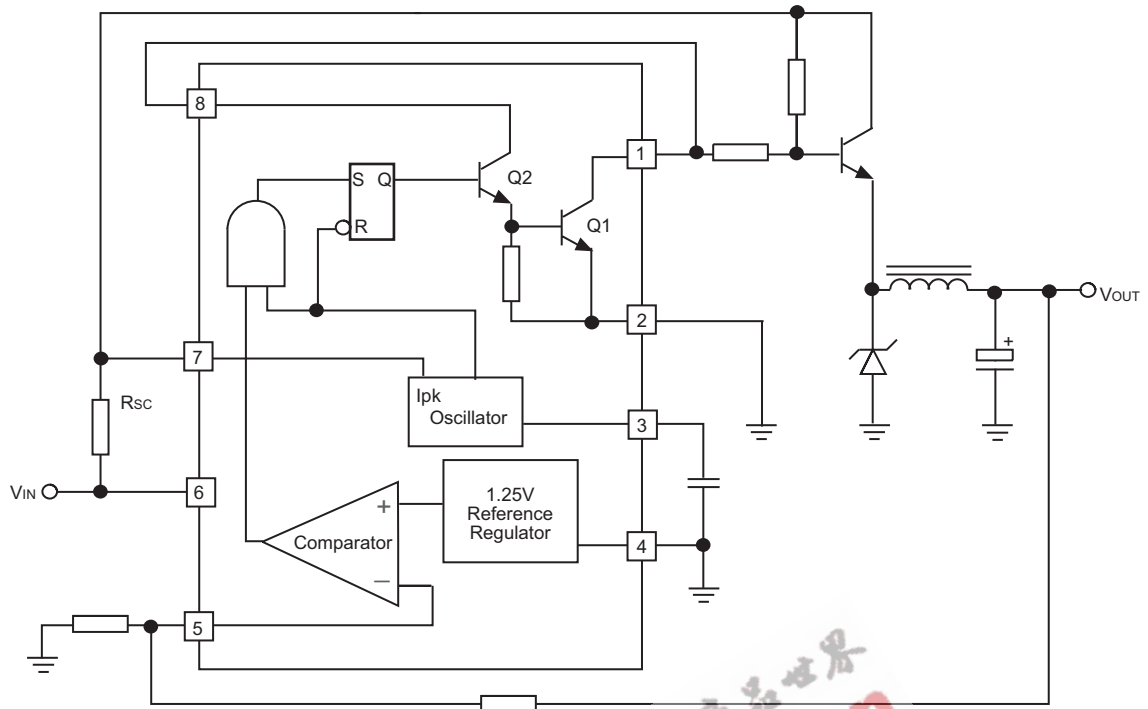

Figure 13. Step-down with External PNP Switch

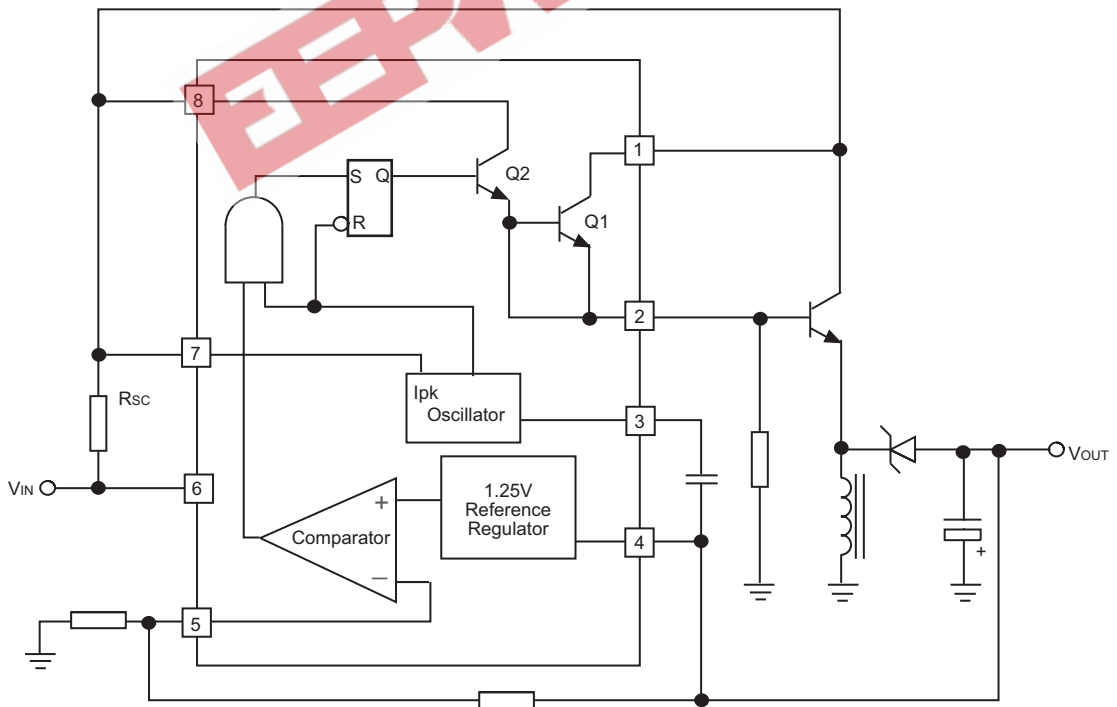

Figure 14. Voltage Inverting with External NPN Switch

TYPICAL APPLICATION(CONTINUED)

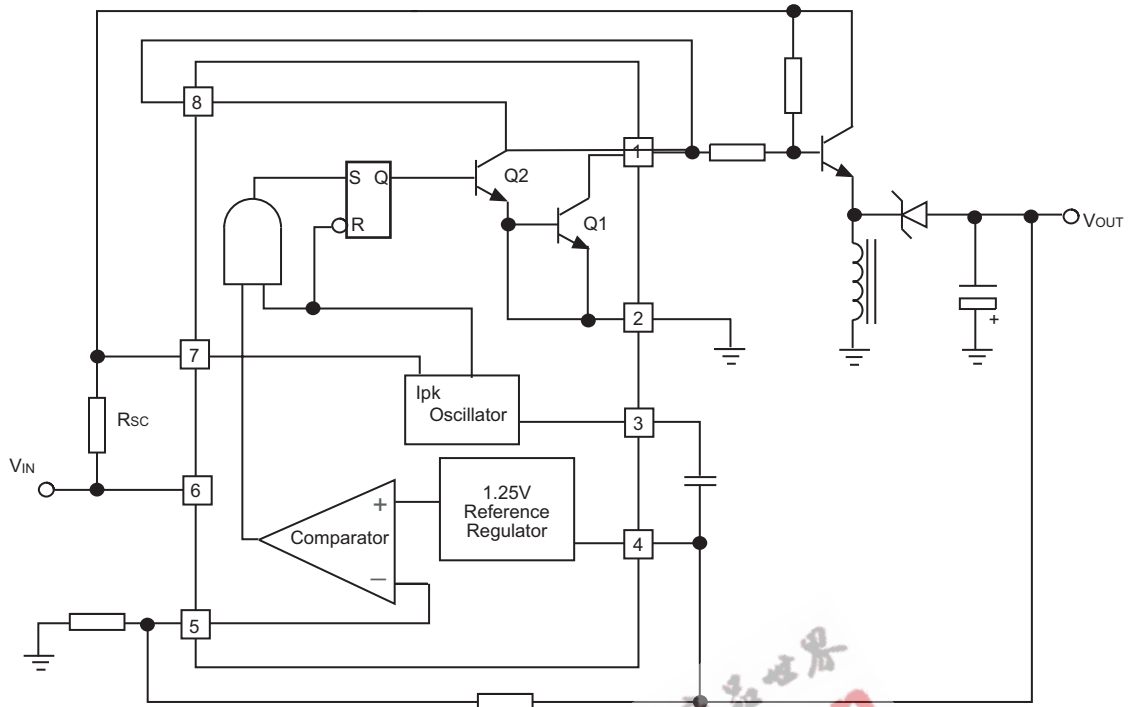

Figure 15. Voltage Inverting with External PNP Saturated Switch

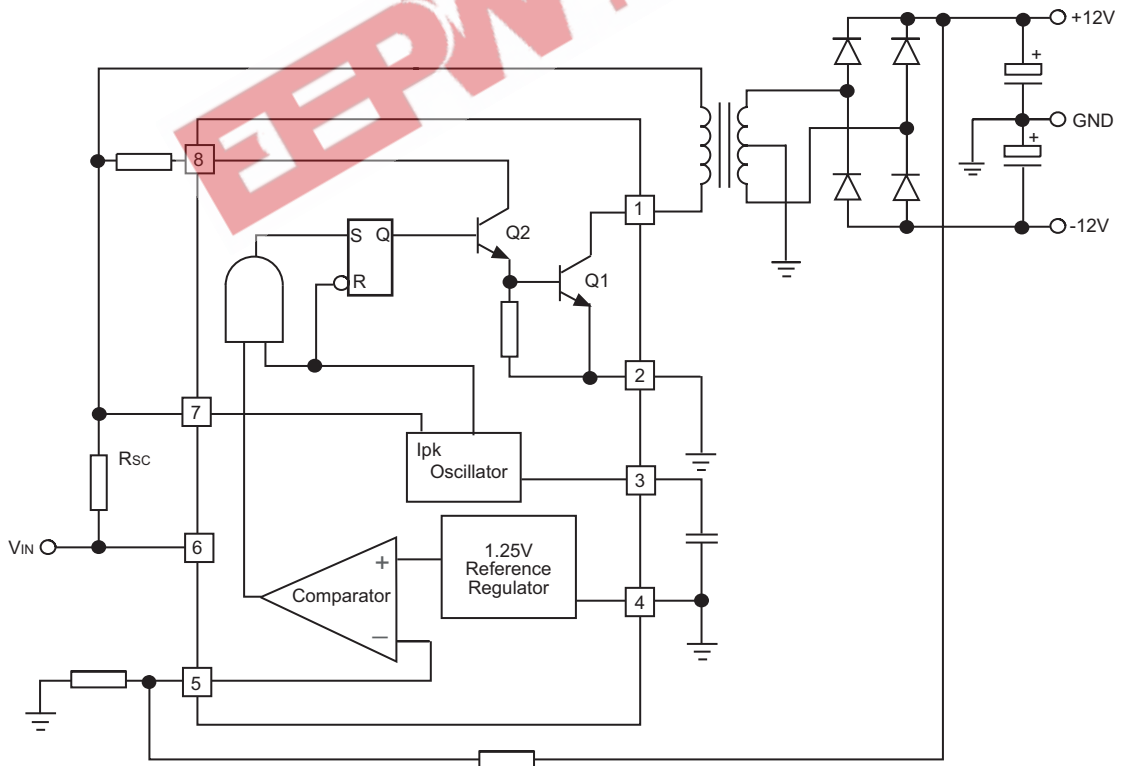

Figure 16. Dual Output Voltage

TYPICAL APPLICATION(CONTINUED)

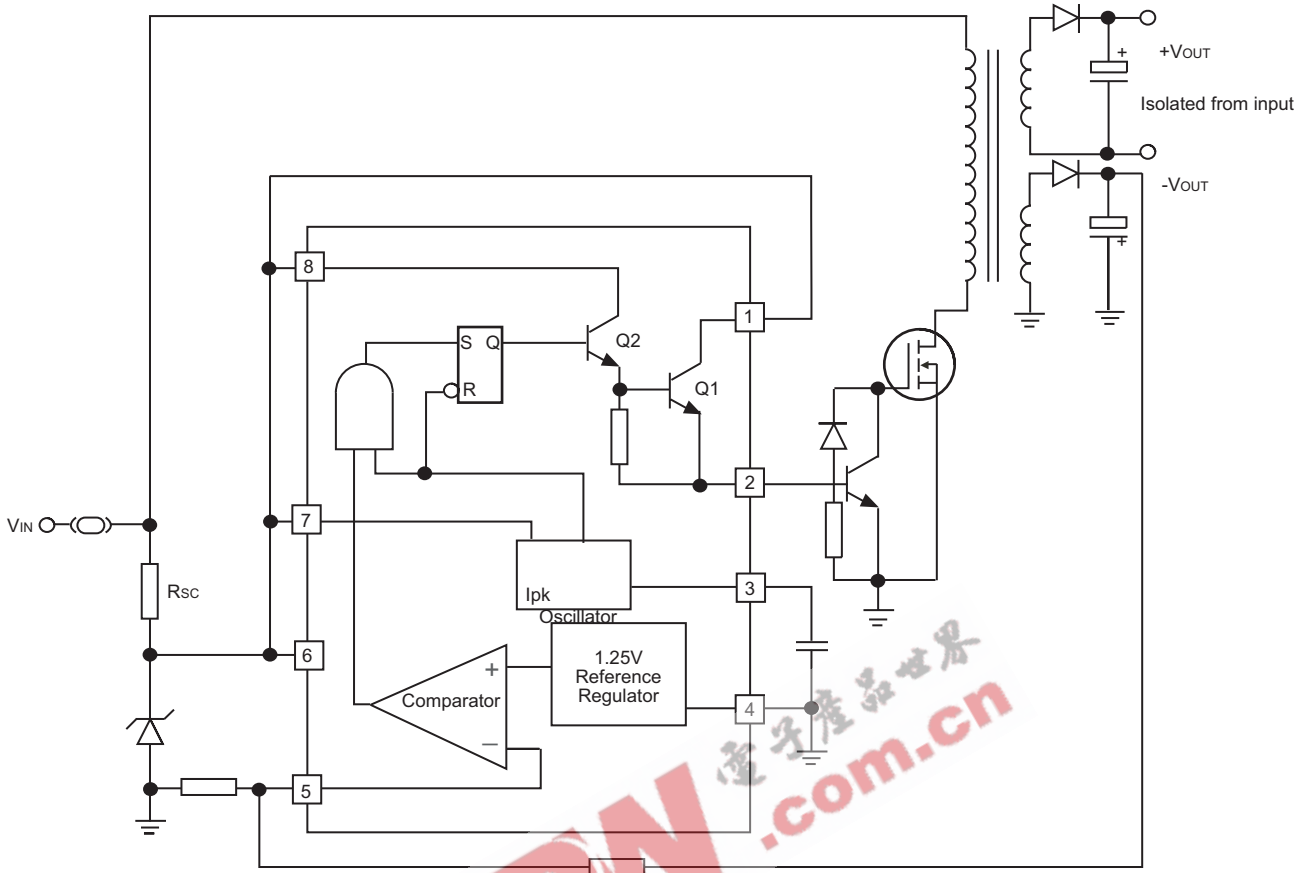

Figure 17. Higher Output Power, Higher Input Voltage

CALCULATION

Table 1 Design Formula Table

Calculation	Step-Up	Step-Down	Voltage-Inverting
t_{on}/t_{off}	$\frac{V_{out} + V_F - V_{in(min)}}{V_{in(min)} - V_{sat}}$	$\frac{V_{out} + V_F}{V_{in(min)} - V_{sat} - V_{out}}$	$\frac{ V_{out} + V_F}{V_{in} - V_{sat}}$
$(t_{on}+t_{off})_{max}$	$\frac{1}{f}$	$\frac{1}{f}$	$\frac{1}{f}$
t_{off}	$\frac{t_{on} + t_{off}}{t_{on}/t_{off} + 1}$	$\frac{t_{on} + t_{off}}{t_{on}/t_{off} + 1}$	$\frac{t_{on} + t_{off}}{t_{on}/t_{off} + 1}$
t_{on}	$(t_{on} + t_{off}) - t_{off}$	$(t_{on} + t_{off}) - t_{off}$	$(t_{on} + t_{off}) - t_{off}$
C_T	$4.0 \times 10^{-5} t_{on}$	$4.0 \times 10^{-5} t_{on}$	$4.0 \times 10^{-5} t_{on}$
$I_{pk(switch)}$	$2I_{out(max)} \left(\frac{t_{on}}{t_{off}} + 1 \right)$	$2I_{out(max)}$	$2I_{out(max)} \left(\frac{t_{on}}{t_{off}} + 1 \right)$
R_{sc}	$\frac{0.3}{I_{PK(switch)}}$	$\frac{0.3}{I_{PK(switch)}}$	$\frac{0.3}{I_{PK(switch)}}$
$L_{(min)}$	$\frac{(V_{in(min)} - V_{sat})}{I_{pk(switch)}} t_{on(max)}$	$\frac{(V_{in(min)} - V_{sat} - V_{out})}{I_{pk(switch)}} t_{on(max)}$	$\frac{(V_{in(min)} - V_{sat})}{I_{pk(switch)}} t_{on(max)}$
C_o	$\approx \frac{I_{out} t_{on}}{V_{ripple(p-p)}}$	$\frac{I_{pk(switch)}(t_{on} + t_{off})}{8V_{ripple(p-p)}}$	$\approx \frac{I_{out} t_{on}}{V_{ripple(p-p)}}$

V_{sat} =Saturation voltage of the output switch.

V_F =Forward voltage drop of the output rectifier.

The following power supply characteristics must be chosen:

V_{in} =Nominal input voltage.

V_{out} =Desired output voltage. $|V_{out}| = 1.25(1+R_2/R_1)$

I_{out} =Desired output current.

f_{min} =Minimum desired output switching frequency at the selected values of V_{in} and I_o

$V_{ripple(pp)}$ =Desired peak-to-peak output ripple voltage. In practice, the calculated capacitor value will need to be increased due to its equivalent series resistance and board layout.

The ripple should be kept to a low value since it will directly affect the line and load regulation.

PHYSICAL DIMENSIONS SOP8L

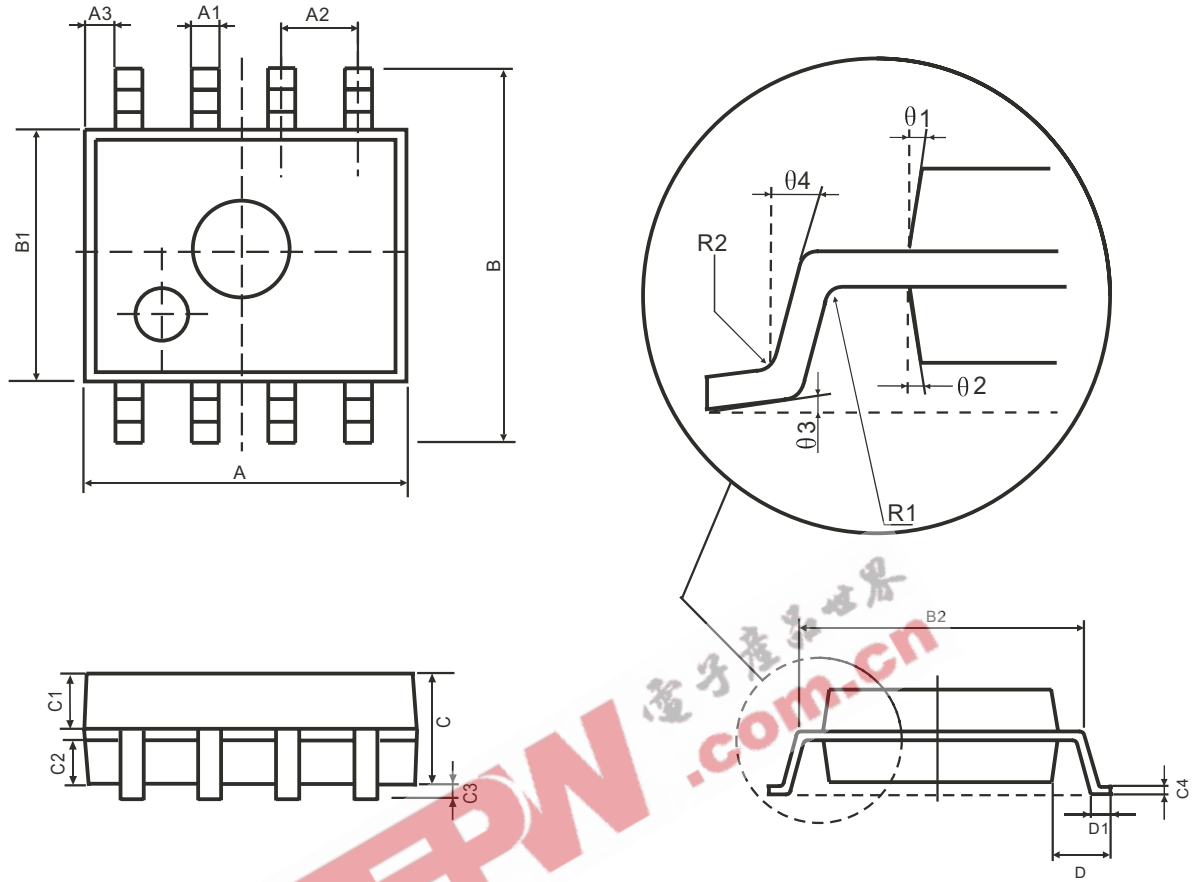

Symbol	Dimension(mm)		Symbol	Dimension(mm)	
	Min	Max		Min	Max
A	4.95	5.15	C3	0.05	0.20
A1	0.37	0.47	C4	0.20(TYP)	
A2	1.27(TYP)		D	1.05(TYP)	
A3	0.41(TYP)		D1	0.40	0.60
B	5.80	6.20	R1	0.07(TYP)	
B1	3.80	4.00	R2	0.07(TYP)	
B2	5.0(TYP)		θ1	17°(TYP)	
C	1.30	1.50	θ2	13°(TYP)	
C1	0.55	0.65	θ3	4°(TYP)	
C2	0.55	0.65	θ4	12°(TYP)	

DIP8L

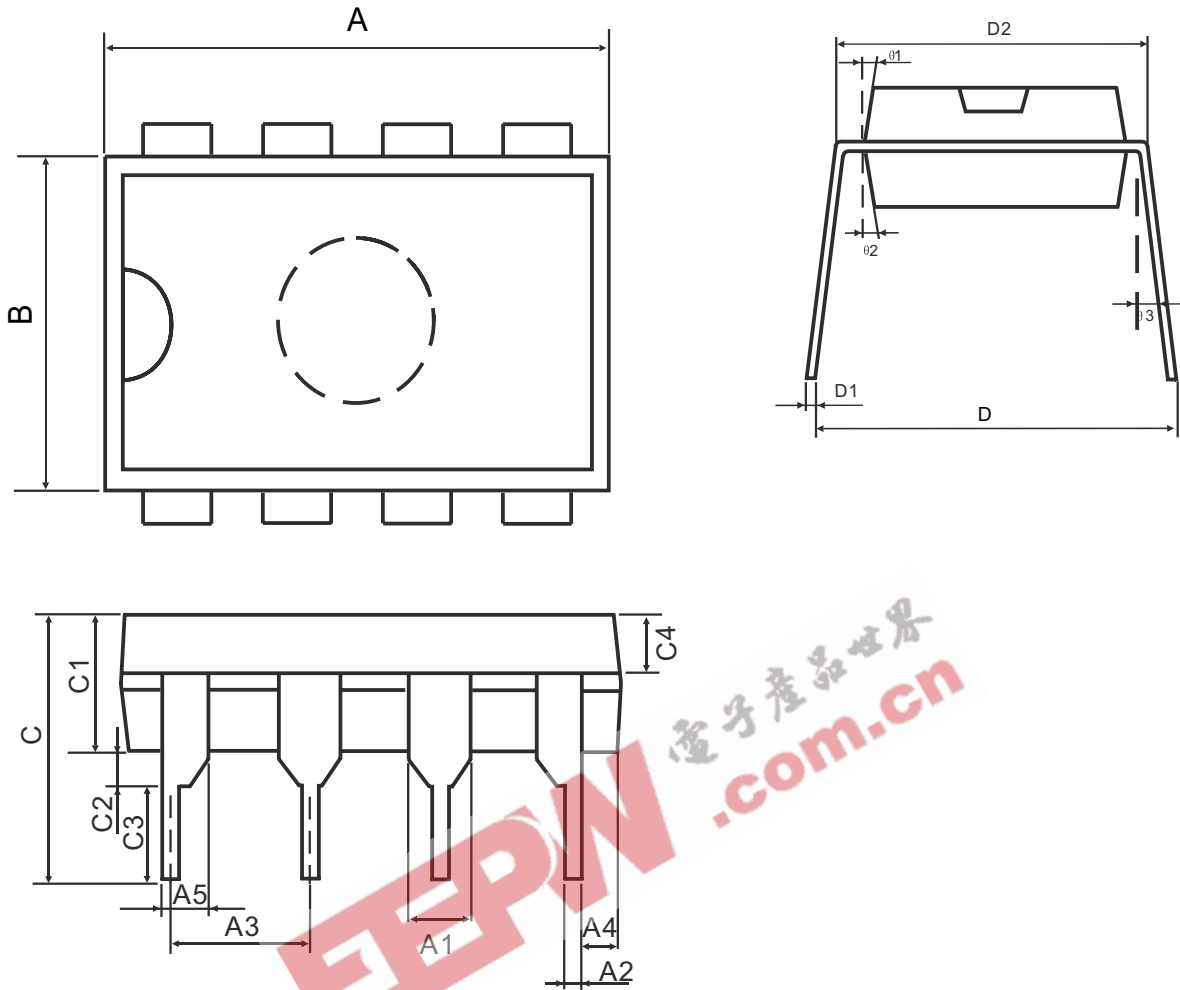

Symbol	Dimension(mm)		Symbol	Dimension(mm)	
	Min	Max		Min	Max
A	9.30	9.50	C2	0.5(TYP)	
A1	1.524(TYP)		C3	3.3(TYP)	
A2	0.39	0.53	C4	1.57(TYP)	
A3	2.54(TYP)		D	8.20	8.80
A4	0.66(TYP)		D1	0.20	0.35
A5	0.99(TYP)		D2	7.62	7.87
B	6.3	6.5	$\theta 1$	8°(TYP)	
C	7.20(TYP)		$\theta 2$	8°(TYP)	
C1	3.30	3.50	$\theta 3$	5°(TYP)	