



MC34063AB - MC34063AC MC34063EB - MC34063EC

DC/DC converter control circuits

Features

- Output switch current in excess of 1.5 A
- 2 % reference accuracy
- Low quiescent current: 2.5 mA (typ.)
- Operating from 3 V to 40 V
- Frequency operation to 100 kHz
- Active current limiting

Description

The MC34063A/E series is a monolithic control circuit delivering the main functions for DC/DC voltage converting.

The device contains an internal temperature compensated reference, comparator, duty cycle controlled oscillator with an active current limit circuit, driver and high current output switch. Output voltage is adjustable through two external resistors with a 2 % reference accuracy.

Employing a minimum number of external components the MC34063A/E devices series is

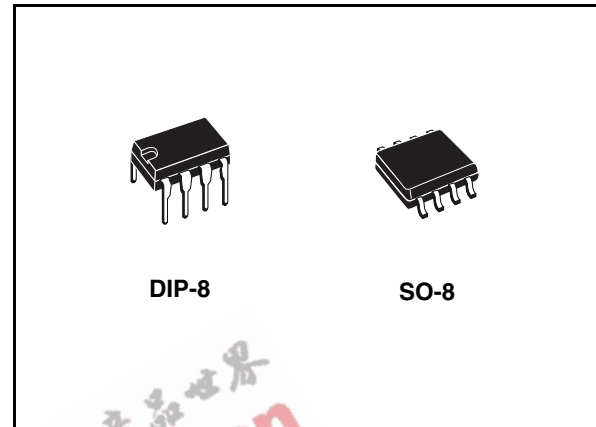

designed for step-down, step-up and voltage-inverting applications.

Table 1. Device summary

Order codes	
DIP-8	SO-8
MC34063ABN ⁽¹⁾	MC34063ABD-TR
MC34063ACN ⁽¹⁾	MC34063ACD-TR
MC34063EBN	MC34063EBD-TR
MC34063ECN	MC34063ECD-TR

1. The "A" version is not recommended for new designs.

Contents

1	Diagram	3
2	Pin configuration	4
3	Maximum ratings	5
4	Electrical characteristics	6
5	Typical performance characteristics	8
6	Typical application circuit	10
7	Package mechanical data	18
8	Revision history	22

EEPW 电子产品世界
.com.cn

1 Diagram

Figure 1. Block diagram

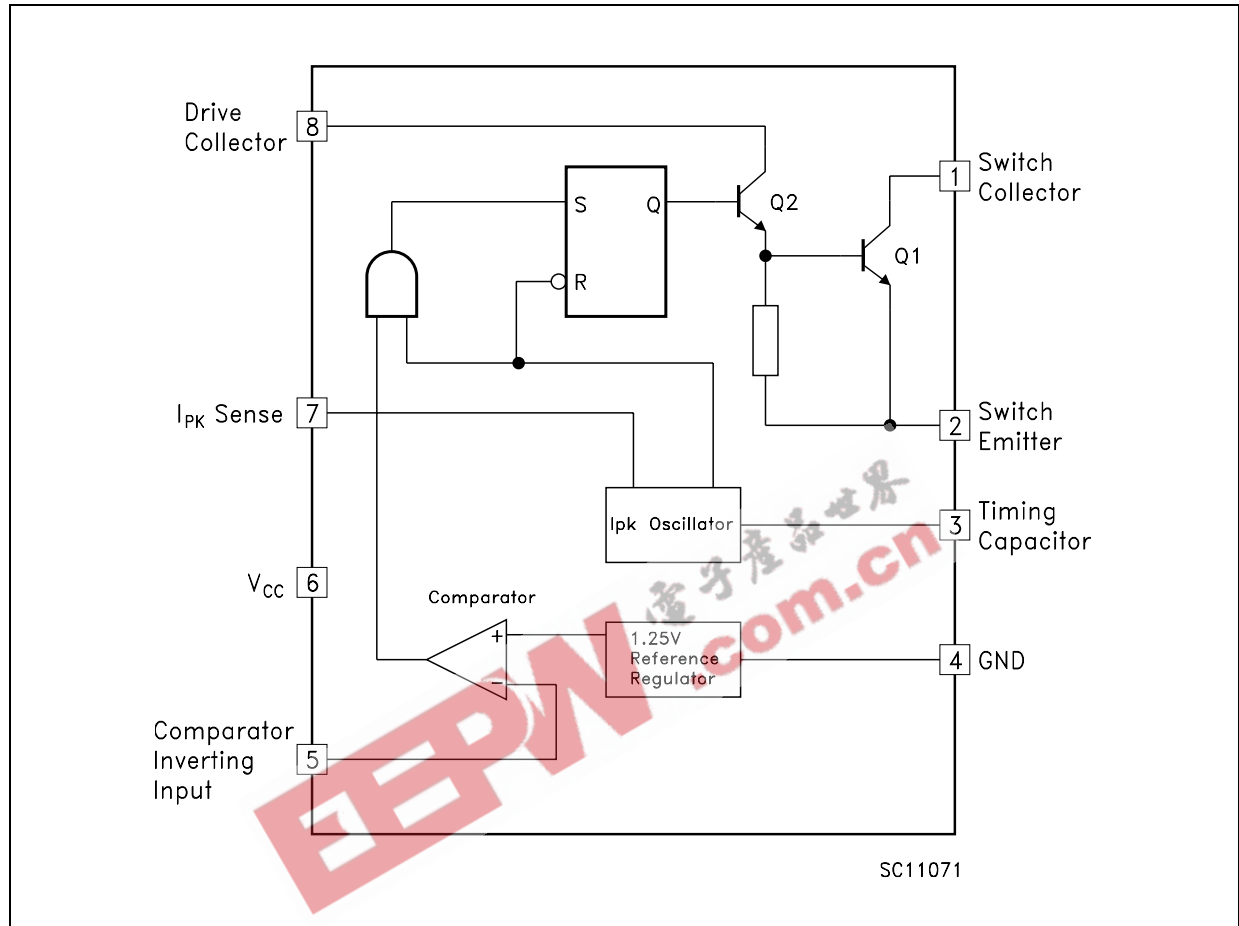

2 Pin configuration

Figure 2. Pin connections

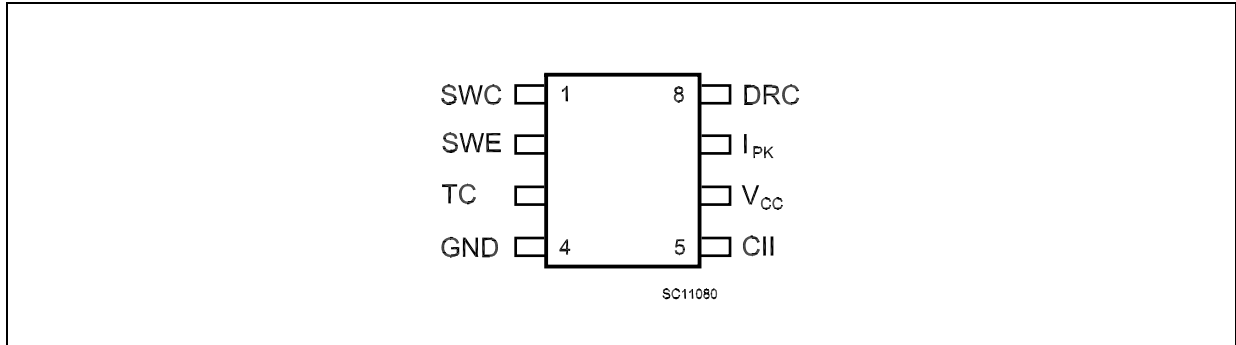

Table 2. Pin description

Pin n°	Symbol	Name and function
1	SWC	Switch collector
2	SWE	Switch emitter
3	TC	Timing capacitor
4	GND	Ground
5	CII	Comparator inverting input
6	V _{CC}	Voltage supply
7	I _{PK}	I _{PK} sense
8	DRC	Voltage driver collector

3 Maximum ratings

Table 3. Absolute maximum ratings

Symbol	Parameter		Value	Unit
V_{CC}	Power supply voltage		50	V
V_{IR}	Comparator input voltage range		-0.3 to 40	V
V_{SWC}	Switch collector voltage		40	V
V_{SWE}	Switch emitter voltage ($V_{SWC} = 40V$)		40	V
V_{CE}	Switch collector to emitter voltage		40	V
V_{DC}	Driver collector voltage		40	V
I_{DC}	Driver collector current		100	mA
I_{SW}	Switch current		1.5	A
P_{TOT}	Power dissipation at $T_A = 25^\circ C$	for DIP-8	1.25	W
		for SO-8	0.625	
T_J	Operating junction temperature		150	$^\circ C$
T_{STG}	Storage temperature range		-40 to 150	$^\circ C$
T_{OP}	Operating ambient temperature range	for AC and EC series	0 to 70	$^\circ C$
		for AB series	-40 to 85	
		for EB series	-40 to 125	

Note: Absolute maximum ratings are those values beyond which damage to the device may occur. Functional operation under these condition is not implied.

Table 4. Thermal data

Symbol	Parameter	DIP-8	SO-8	Unit
R_{thJA}	Thermal resistance junction-ambient ⁽¹⁾	100	160	$^\circ C/W$
R_{thJC}	Thermal resistance junction-case	42	20	$^\circ C/W$

1. This value depends from thermal design of PCB on which the device is mounted.

4 Electrical characteristics

(Refer to the test circuits, $V_{CC} = 5\text{ V}$, $T_A = T_{LOW}$ to T_{HIGH} , unless otherwise specified, see [Note 2](#))

Table 5. Oscillator

Symbol	Parameter	Test conditions	Min.	Typ.	Max.	Unit
f_{OSC}	Frequency	$V_{PIN5} = 0\text{ V}$, $C_T = 1\text{ nF}$, $T_A = 25^\circ\text{C}$	24	33	42	kHz
I_{CHG}	Charge current	$V_{CC} = 5\text{ to }40\text{ V}$, $T_A = 25^\circ\text{C}$	24	33	42	μA
I_{DISCHG}	Discharge current	$V_{CC} = 5\text{ to }40\text{ V}$, $T_A = 25^\circ\text{C}$	140	200	260	μA
I_{DISCHG}/I_{CHG}	Discharge to charge current ratio	$PIN\ 7 = V_{CC}$, $T_A = 25^\circ\text{C}$	5.2	6.2	7.5	μA
$V_{IPK(sense)}$	Current limit sense voltage	$I_{CHG} = I_{DISCHG}$, $T_A = 25^\circ\text{C}$	250	300	350	mV

Table 6. Output switch

Symbol	Parameter	Test conditions	Min.	Typ.	Max.	Unit
$V_{CE(sat)}$	Saturation voltage, darlington connection	$I_{SW} = 1\text{ A}$, $PIN\ 7, 8$ connected		1	1.3	V
$V_{CE(sat)}$	Saturation voltage	$I_{SW} = 1\text{ A}$, $R_{PIN8} = 82\ \Omega$ to V_{CC} Forced $\beta \sim 20$		0.45	0.7	V
h_{FE}	DC current gain	$I_{SW} = 1\text{ A}$, $V_{CE} = 5\text{ V}$, $T_A = 25^\circ\text{C}$	50	120		
$I_{C(off)}$	Collector off-state current	$V_{CE} = 40\text{ V}$		0.01	100	μA

Table 7. Comparator

Symbol	Parameter	Test conditions	Min.	Typ.	Max.	Unit
V_{TH}	Threshold voltage	$T_A = 25^\circ\text{C}$	1.225	1.25	1.275	V
		$T_A = T_{LOW}$ to T_{HIGH}	1.21		1.29	
Reg_{line}	Threshold voltage line regulation	$V_{CC} = 3\text{ to }40\text{ V}$		1	5	mV
I_{IB}	Input bias current	$V_{IN} = 0\text{ V}$		-5	-400	nA

Table 8. Total device

Symbol	Parameter	Test conditions	Min.	Typ.	Max.	Unit	
I _{CC}	Supply current	V _{CC} = 5 to 40 V C _T = 1 nF PIN 7 = V _{CC} V _{PIN5} > V _{TH} PIN 2 = GND Remaining pins open	for MC34063A		2.5	4	mA
			for MC34063E		1.5	4	
V _{START-UP}	Start-up voltage (Note 4)	T _A = 25°C C _T = 1 μF, PIN 5 = 0	for MC34063A		2.1		V
			for MC34063E		1.5		

Note: 1 Maximum package power dissipation limit must be observed.

2 T_{LOW} = 0 °C, T_{HIGH} = 70 °C (AC and EC series); T_{LOW} = -40 °C, T_{HIGH} = 85 °C (AB series);
T_{LOW} = -40 °C, T_{HIGH} = 125 °C (EB series).

3 If darlington configuration is not used, care must be taken to avoid deep saturation of output switch. The resulting switch-off time may be adversely affected. In a darlington configuration the following output driver condition is suggested:

$$\text{Forced } \beta \text{ of output current switch} = I_{\text{COUTPUT}} / (I_{\text{CDRIVER}} - 1 \text{ mA}^{(a)}) \geq 10$$

4 Start-up voltage is the minimum power supply voltage at which the internal oscillator begins to work.

a. Current less due to a built in 1 kΩ anti leakage resistor.

5 Typical performance characteristics

Figure 3. Emitter follower configuration output saturation voltage vs emitter current

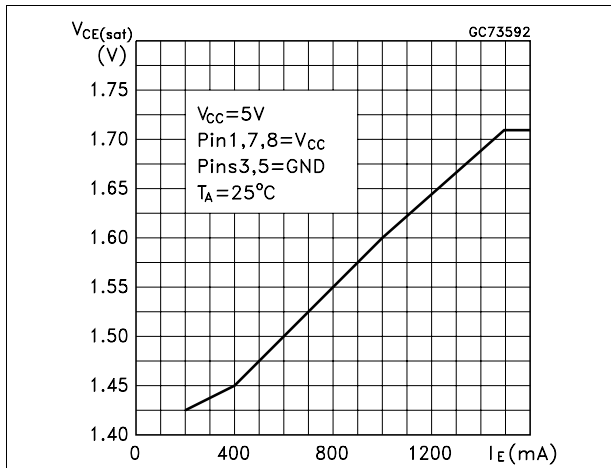

Figure 4. Output switch ON-OFF time vs oscillator timing capacitor

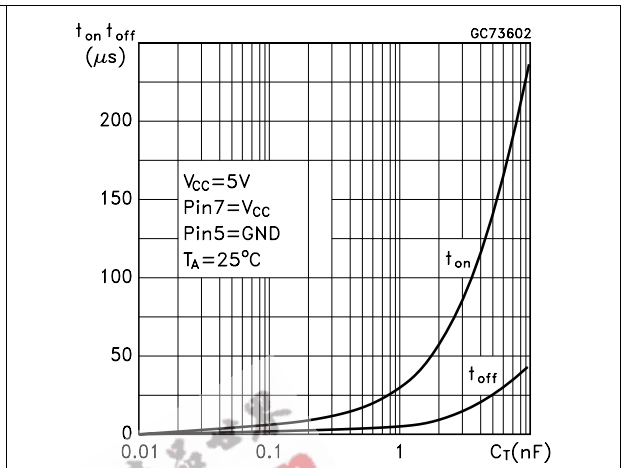

Figure 5. Common emitter configuration output switch saturation voltage vs collector current

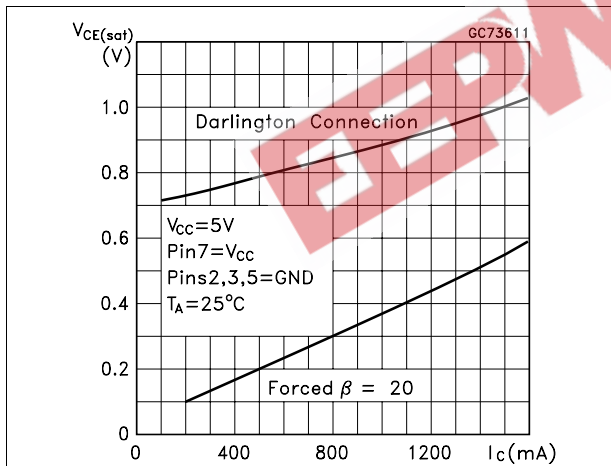

Figure 6. Darlington configuration collector emitter saturation voltage (V_{CEsat}) vs temperature

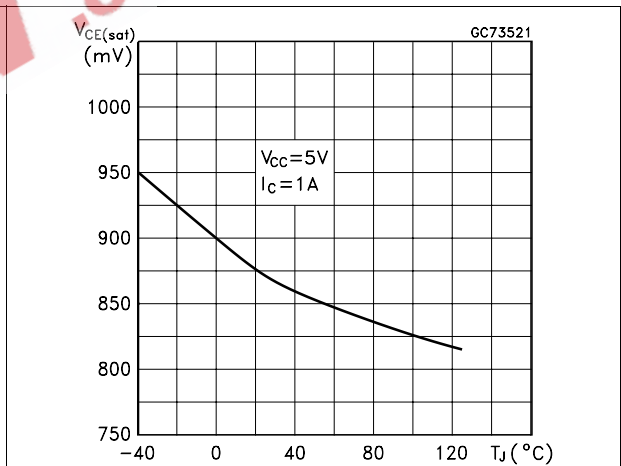

Figure 7. Power collector emitter saturation voltage (V_{CEsat}) vs temperature

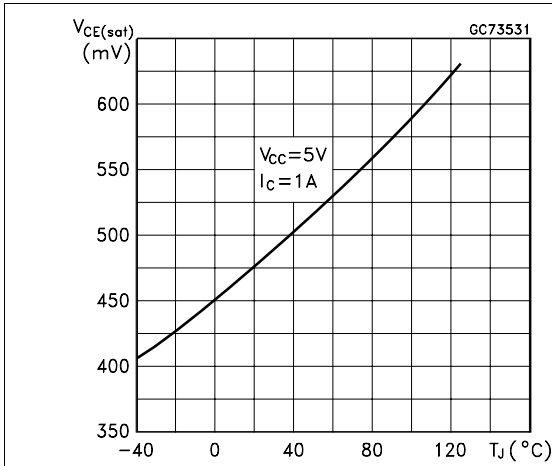

Figure 8. Current limit sense voltage (V_{IPK}) vs temperature

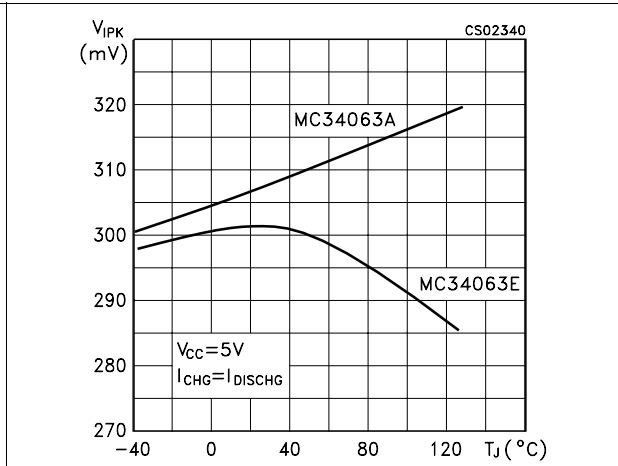

Figure 9. Reference voltage vs temperature

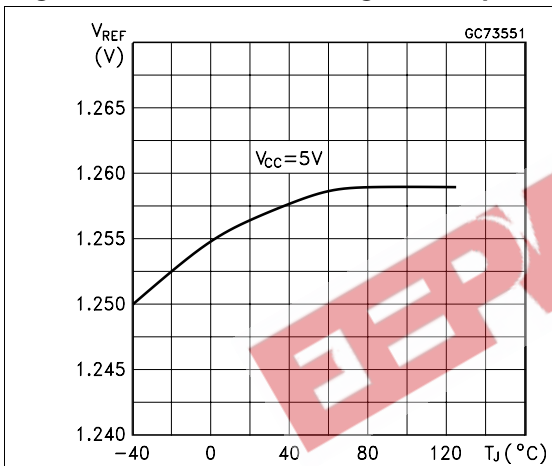

Figure 10. Bias current vs temperature

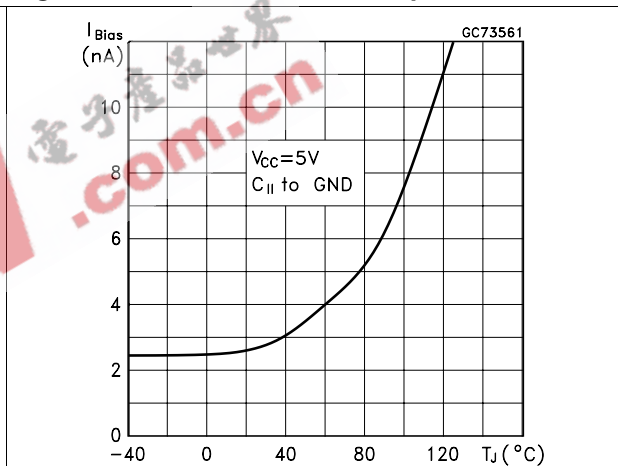

Figure 11. Supply current vs temperature

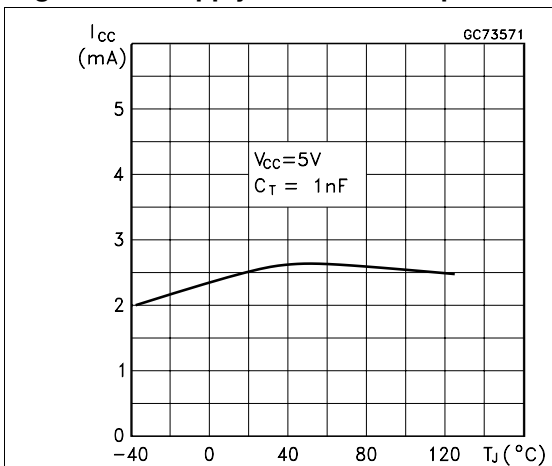
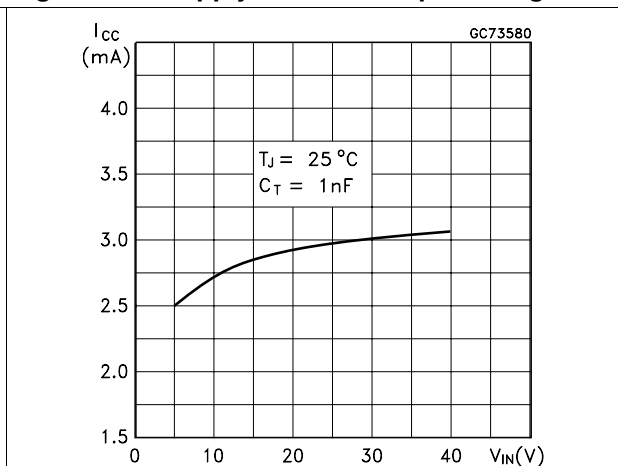

Figure 12. Supply current vs input voltage



6 Typical application circuit

Figure 13. Step-up converter

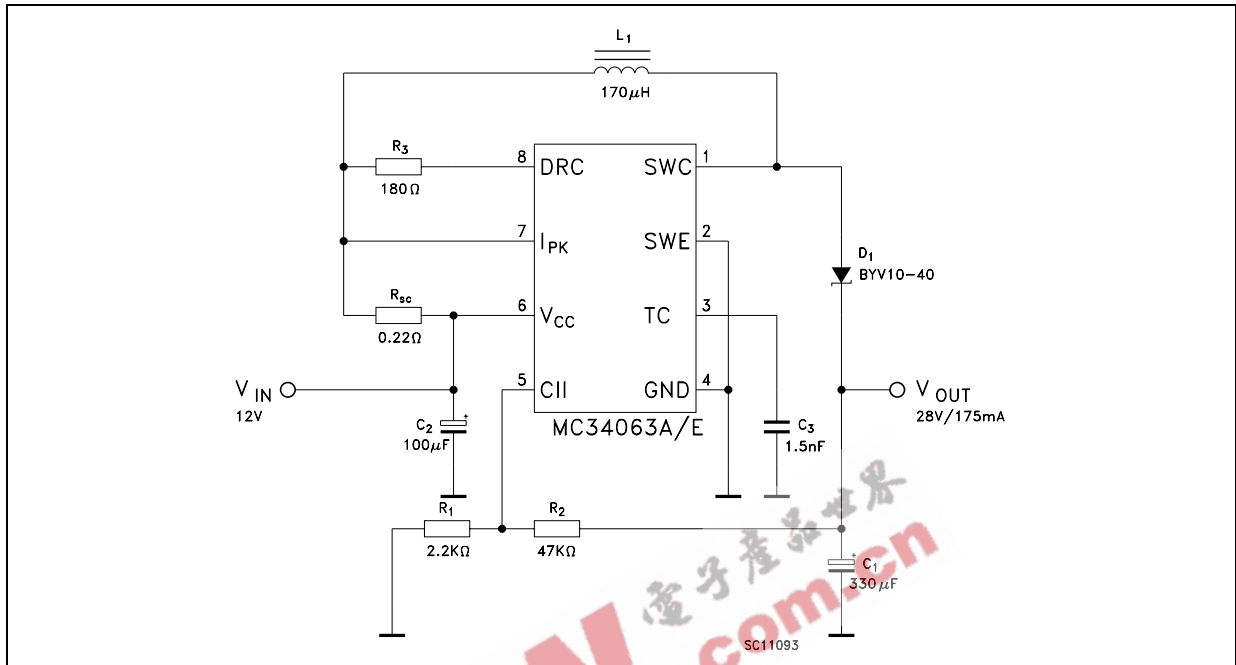

Figure 14. Printed evaluation board

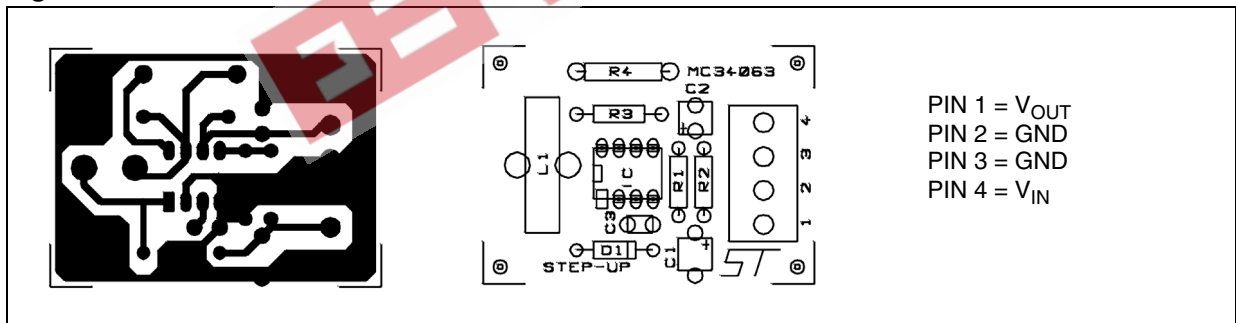

Table 9. Test condition ($V_{OUT} = 28\text{ V}$)

Test	Conditions	Value (Typ.)	Unit
Line Regulation	$V_{IN} = 8\text{ to }16\text{ V}$, $I_O = 175\text{ mA}$	30	mV
Load Regulation	$V_{IN} = 12\text{ V}$, $I_O = 75\text{ to }175\text{ mA}$	10	mV
Output Ripple	$V_{IN} = 12\text{ V}$, $I_O = 175\text{ mA}$	300	mV
Efficiency	$V_{IN} = 12\text{ V}$, $I_O = 175\text{ mA}$	89	%

Figure 15. Step-down converter

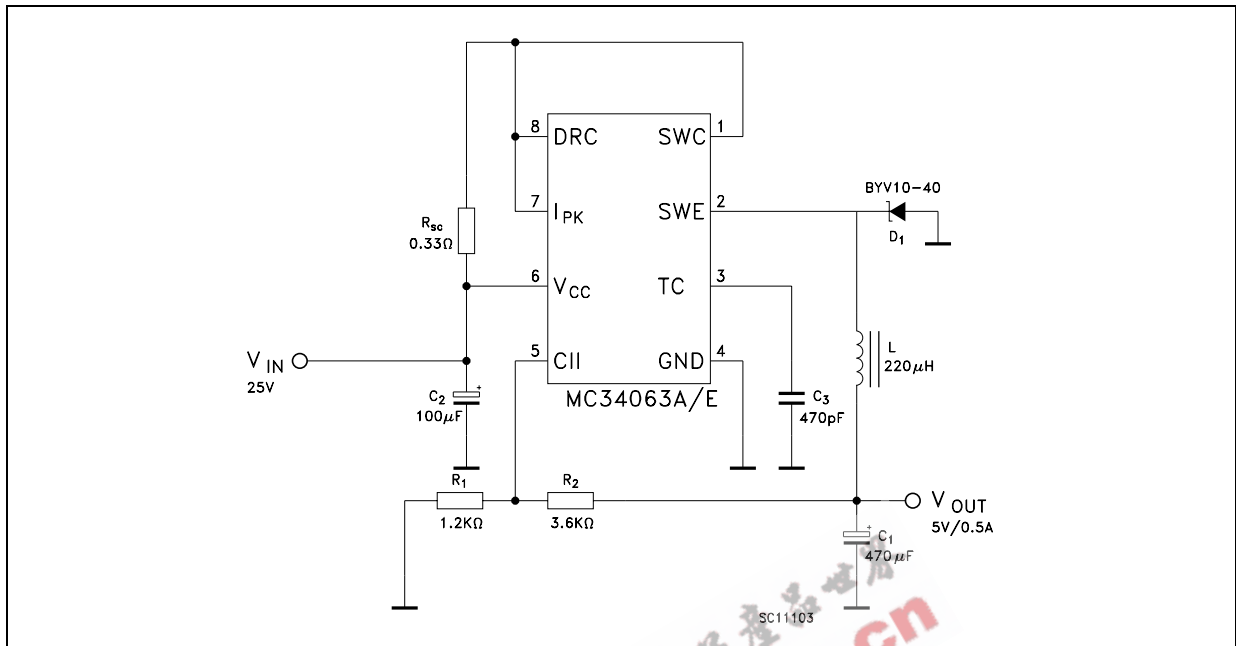

Figure 16. Printed evaluation board

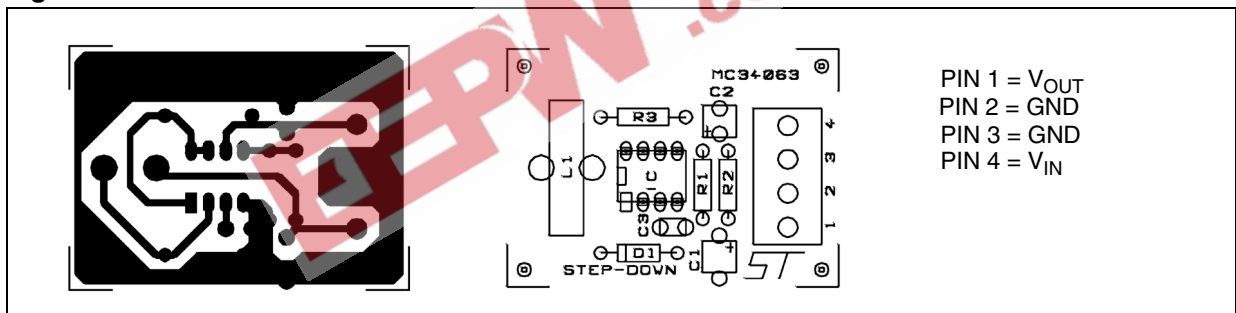

Table 10. Test condition ($V_{OUT} = 5\text{ V}$)

Test	Conditions	Value (typ.)	Unit
Line regulation	$V_{IN} = 15\text{ to }25\text{ V}$, $I_O = 500\text{ mA}$	5	mV
Load regulation	$V_{IN} = 25\text{ V}$, $I_O = 50\text{ to }500\text{ mA}$	30	mV
Output ripple	$V_{IN} = 25\text{ V}$, $I_O = 500\text{ mA}$	100	mV
Efficiency	$V_{IN} = 25\text{ V}$, $I_O = 500\text{ mA}$	80	%
I_{SC}	$V_{IN} = 25\text{ V}$, $R_{LOAD} = 0.1\ \Omega$	1.2	A

Figure 17. Voltage inverting converter

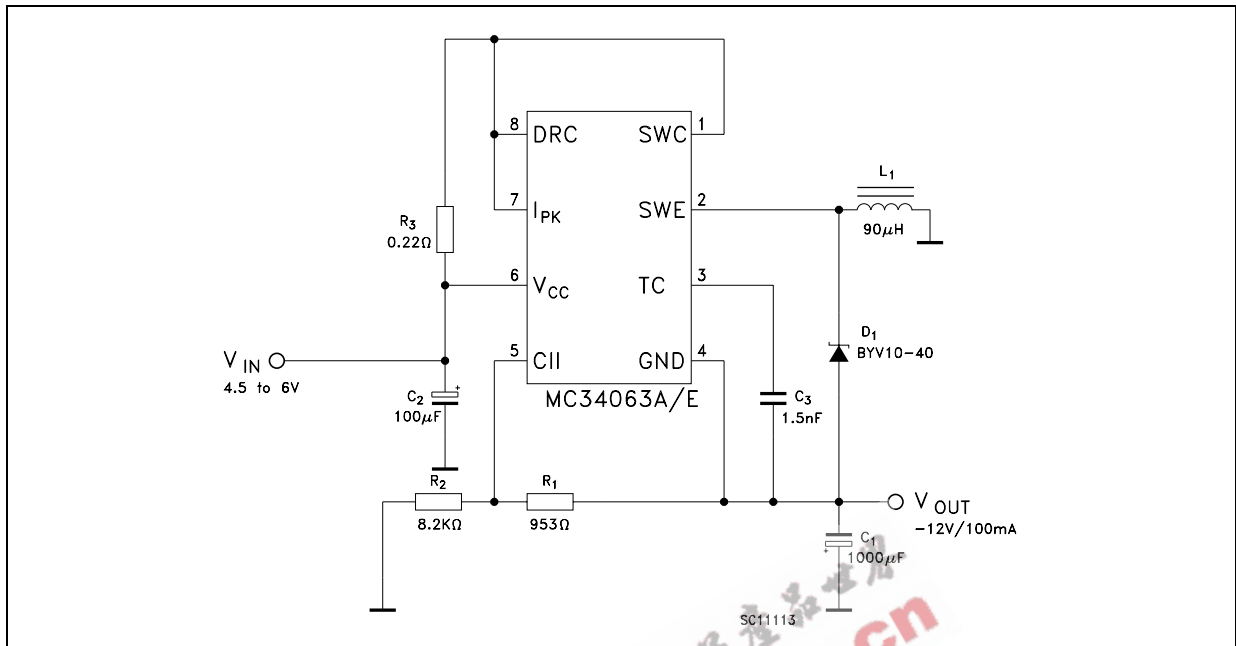

Figure 18. Printed evaluation board

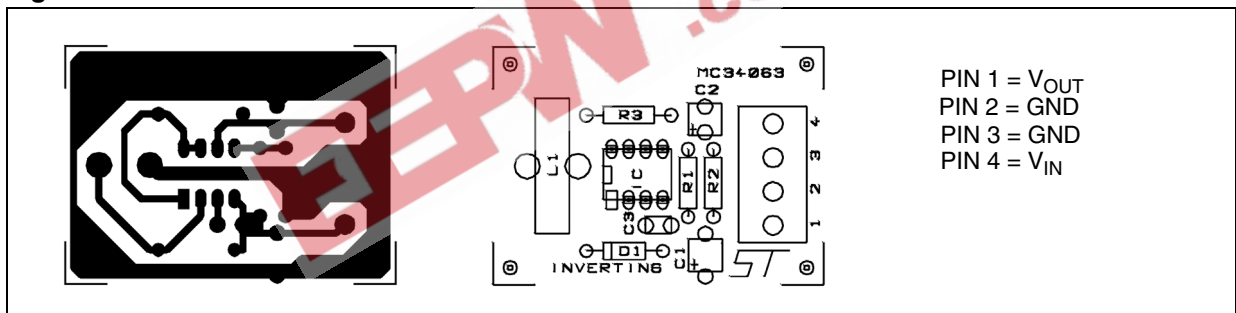

Table 11. Test condition ($V_{OUT} = 12\text{ V}$)

Test	Conditions	Value (typ.)	Unit
Line regulation	$V_{IN} = 4.5\text{ to }6\text{ V}$, $I_O = 100\text{ mA}$	15	mV
Load regulation	$V_{IN} = 5\text{ V}$, $I_O = 10\text{ to }100\text{ mA}$	20	mV
Output ripple	$V_{IN} = 5\text{ V}$, $I_O = 100\text{ mA}$	230	mV
Efficiency	$V_{IN} = 5\text{ V}$, $I_O = 100\text{ mA}$	58	%
I_{SC}	$V_{IN} = 5\text{ V}$, $R_{LOAD} = 0.1\ \Omega$	0.9	A

Table 12. Calculation

Parameter	Step-Up (Discontinuous mode)	Step-Down (Continuous mode)	Voltage Inverting (Discontinuous mode)
t_{on}/t_{off}	$\frac{V_{OUT} + V_F - V_{IN(mi)}}{V_{IN(min)} - V_{sat}}$	$\frac{V_{OUT} + V_F}{V_{N(min)} - V_{sat} - V_{OL}}$	$\frac{ V_{OUT} + V_F}{V_{IN} - V_{sat}}$
$(t_{on} + t_{off}) \max$	$1/f_{min}$	$1/f_{min}$	$1/f_{min}$
C_T	$4.5 \times 10^{-5} t_{on}$	$4.5 \times 10^{-5} t_{on}$	$4.5 \times 10^{-5} t_{on}$
$I_{PK(switch)}$	$2I_{out(max)}[(t_{on}/t_{off})+1]$	$2I_{out(max)}$	$2I_{out(max)}[(t_{on}/t_{off})+1]$
R_{SC}	$0.3/I_{PK(switch)}$	$0.3/I_{PK(switch)}$	$0.3/I_{PK(switch)}$
C_O	$\frac{I_{out} t_{on}}{V_{ripple(p-p)}}$	$\frac{I_{PK(switch)}(t_{on} + t_{off})}{8V_{ripple(p-p)}}$	$\frac{I_{out} t_{on}}{V_{ripple(p-p)}}$
$L_{(min)}$	$\frac{I_{N(min)} - V_{sat}}{I_{PK(switch)}} \times t_{on(mi)}$	$\frac{I_{(min)} - V_{sat} - V_{out}}{I_{PK(switch)}} \times t_{on($	$\frac{I_{N(min)} - V_{sat}}{I_{PK(switch)}} \times t_{on(mi)}$

Note:

 V_{SAT} = Saturation voltage of the output switch V_F = Forward voltage drop of the output rectifier

The following power supply characteristics must be chosen:

 V_{IN} = Nominal input voltage V_{OUT} = Desired output voltage, $|V_{OUT}| = 1.25 (1 + R_2/R_1)$ I_{OUT} = Desired output current f_{MIN} = Minimum desired output switching frequency at the selected values of V_{IN} and I_O V_{RIPPLE} = Desired peak to peak output ripple voltage. In practice, the calculated capacitor value will and to be increased due to its equivalent series resistance and board layout. The ripple voltage should be kept to a low value since it will directly affect the line and load regulation.

Figure 19. Step-up with external NPN switch

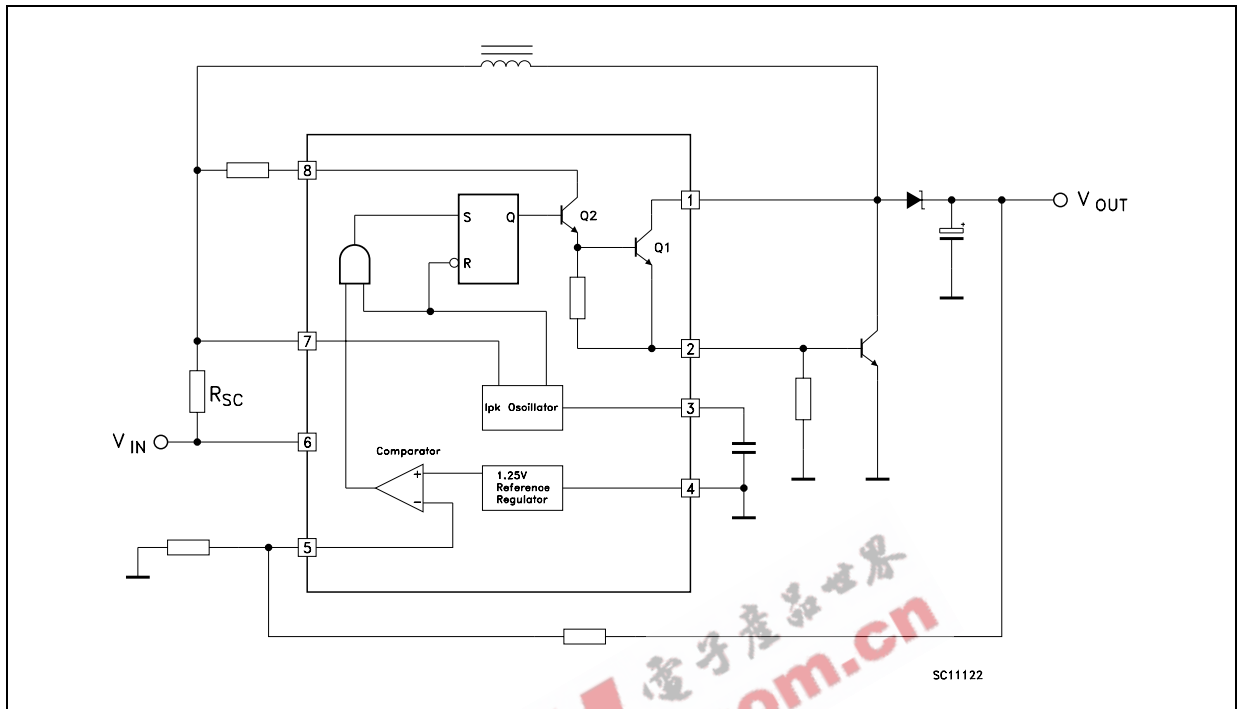

Figure 20. Step-down with external NPN switch

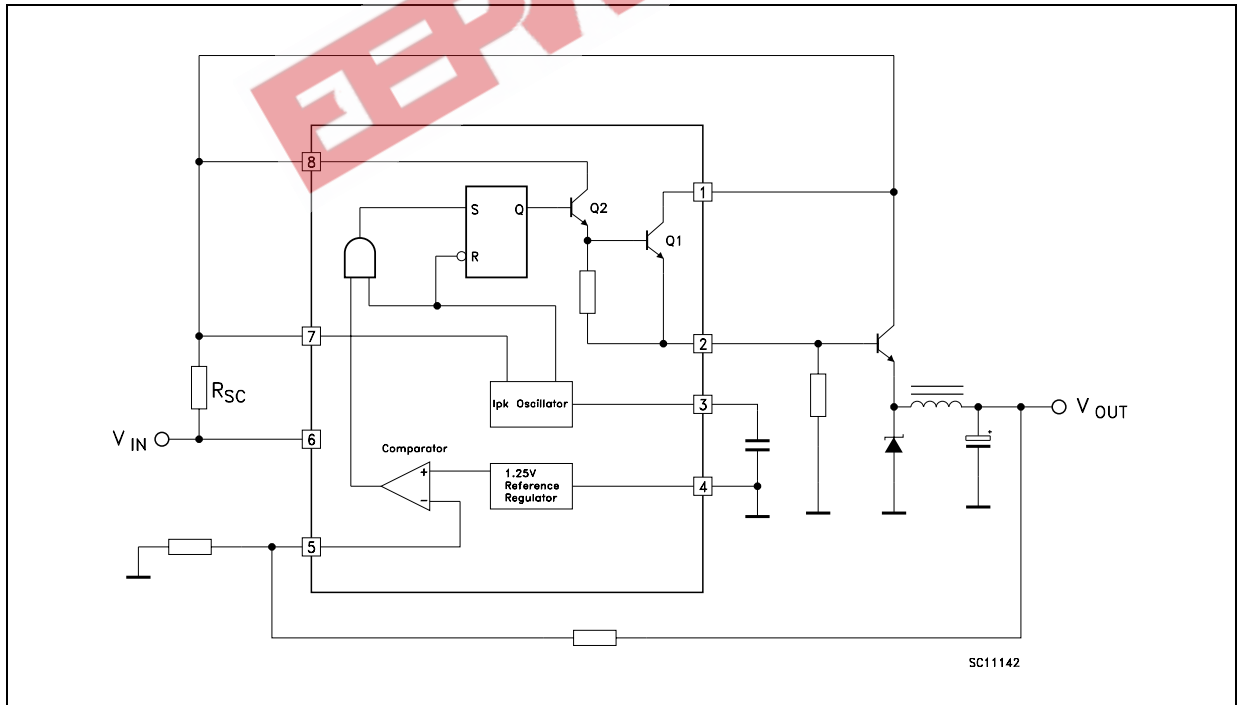

Figure 21. Step-down with external PNP switch

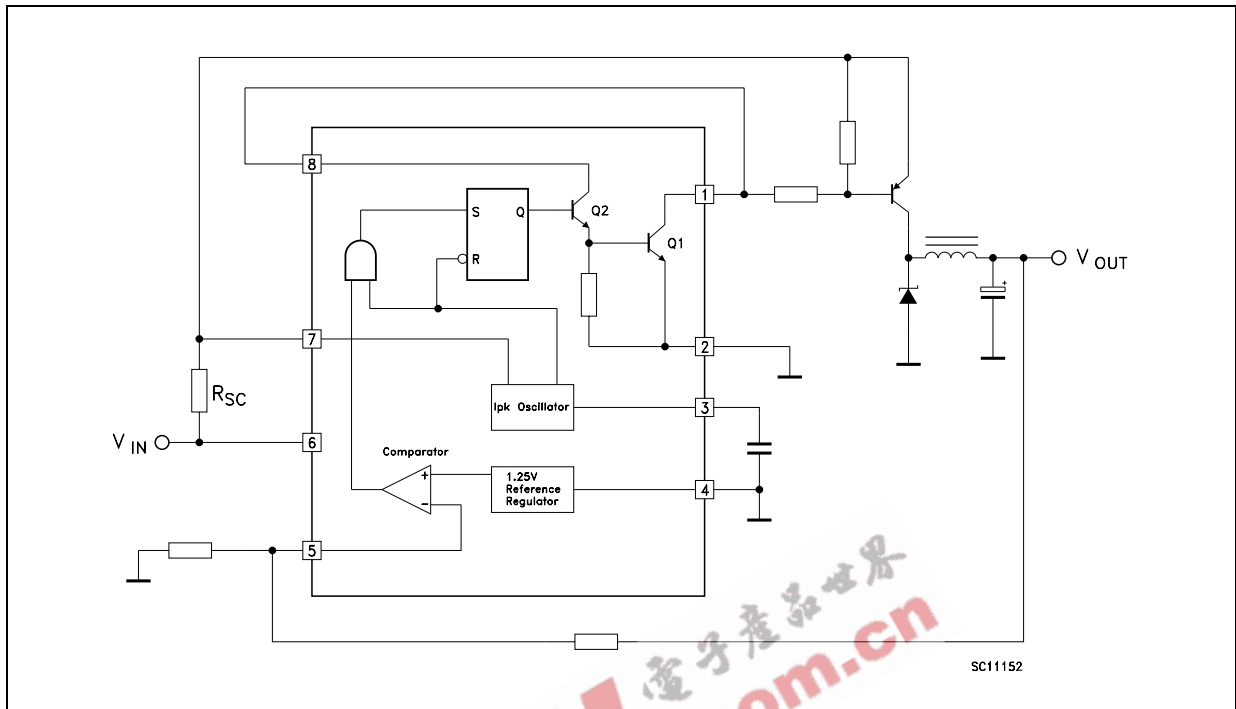

Figure 22. Voltage inverting with external NPN switch

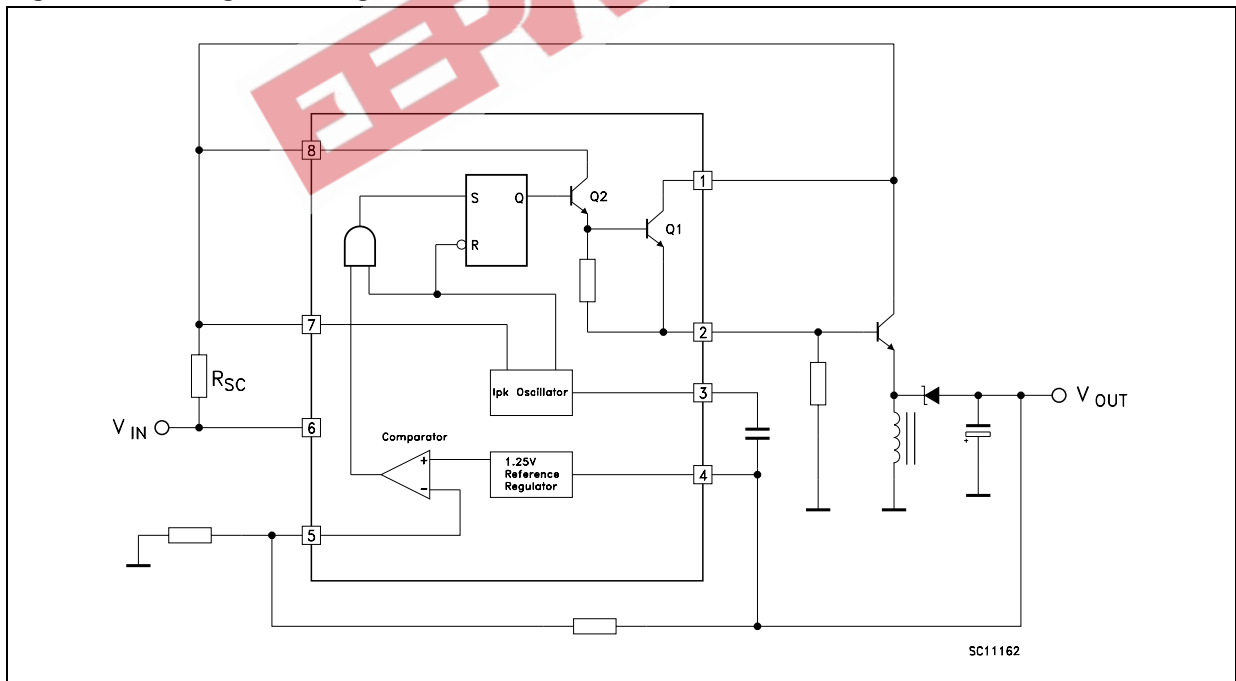

Figure 23. Voltage inverting with external PNP saturated switch

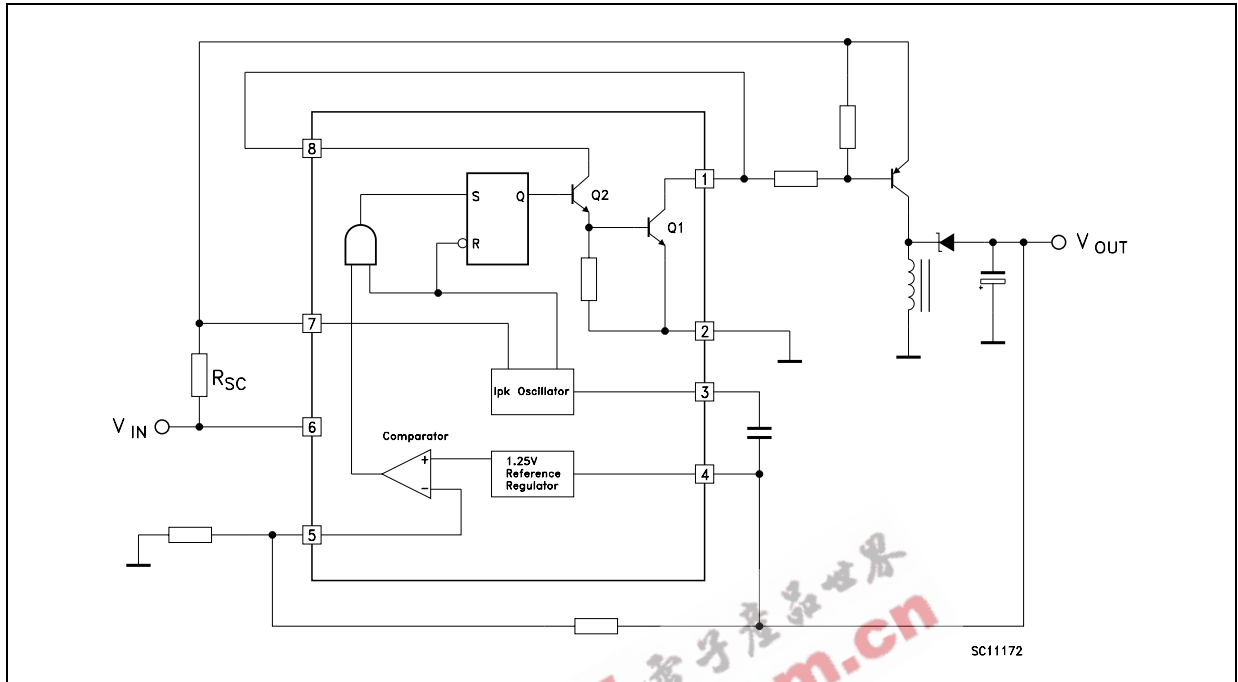

Figure 24. Dual output voltage

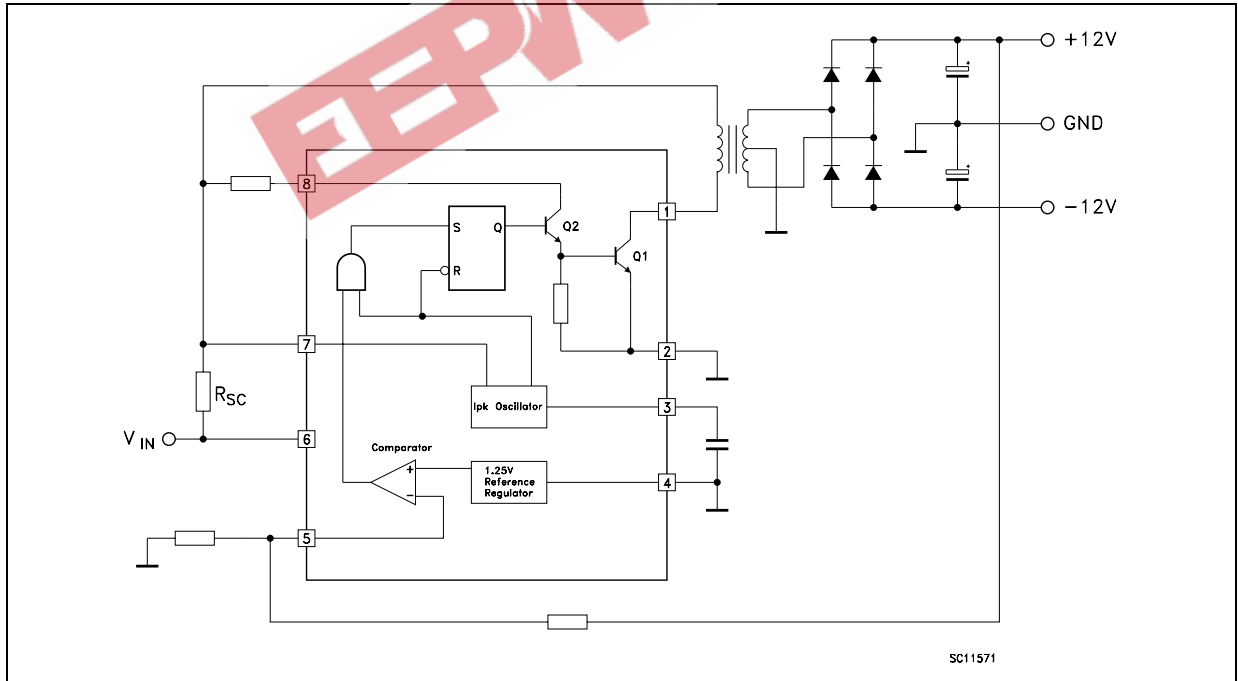
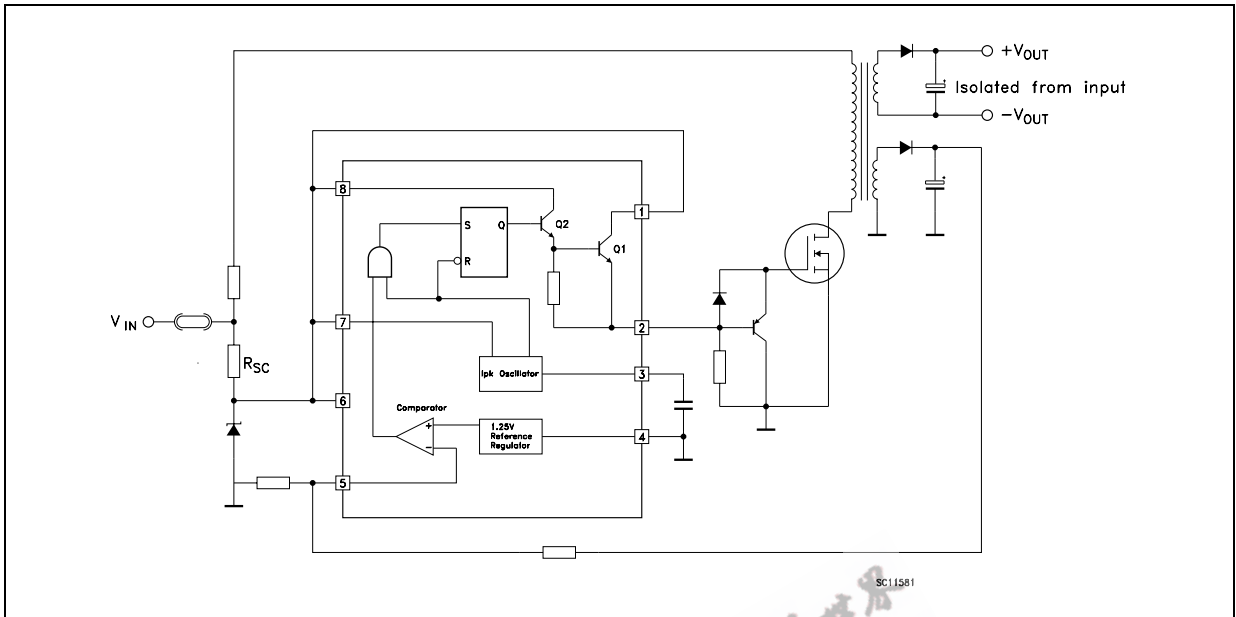

Figure 25. Higher output power, higher input voltage



7 Package mechanical data

In order to meet environmental requirements, ST offers these devices in ECOPACK® packages. These packages have a lead-free second level interconnect. The category of second level interconnect is marked on the package and on the inner box label, in compliance with JEDEC Standard JESD97. The maximum ratings related to soldering conditions are also marked on the inner box label. ECOPACK is an ST trademark. ECOPACK specifications are available at: www.st.com

EEPW 电子产品世界
.com.cn

Plastic DIP-8 mechanical data

Dim.	mm.			inch.		
	Min.	Typ.	Max.	Min.	Typ.	Max.
A		3.3			0.130	
a1	0.7			0.028		
B	1.39		1.65	0.055		0.065
B1	0.91		1.04	0.036		0.041
b		0.5			0.020	
b1	0.38		0.5	0.015		0.020
D			9.8			0.386
E		8.8			0.346	
e		2.54			0.100	
e3		7.62			0.300	
e4		7.62			0.300	
F			7.1			0.280
I			4.8			0.189
L		3.3			0.130	
Z	0.44		1.6	0.017		0.063

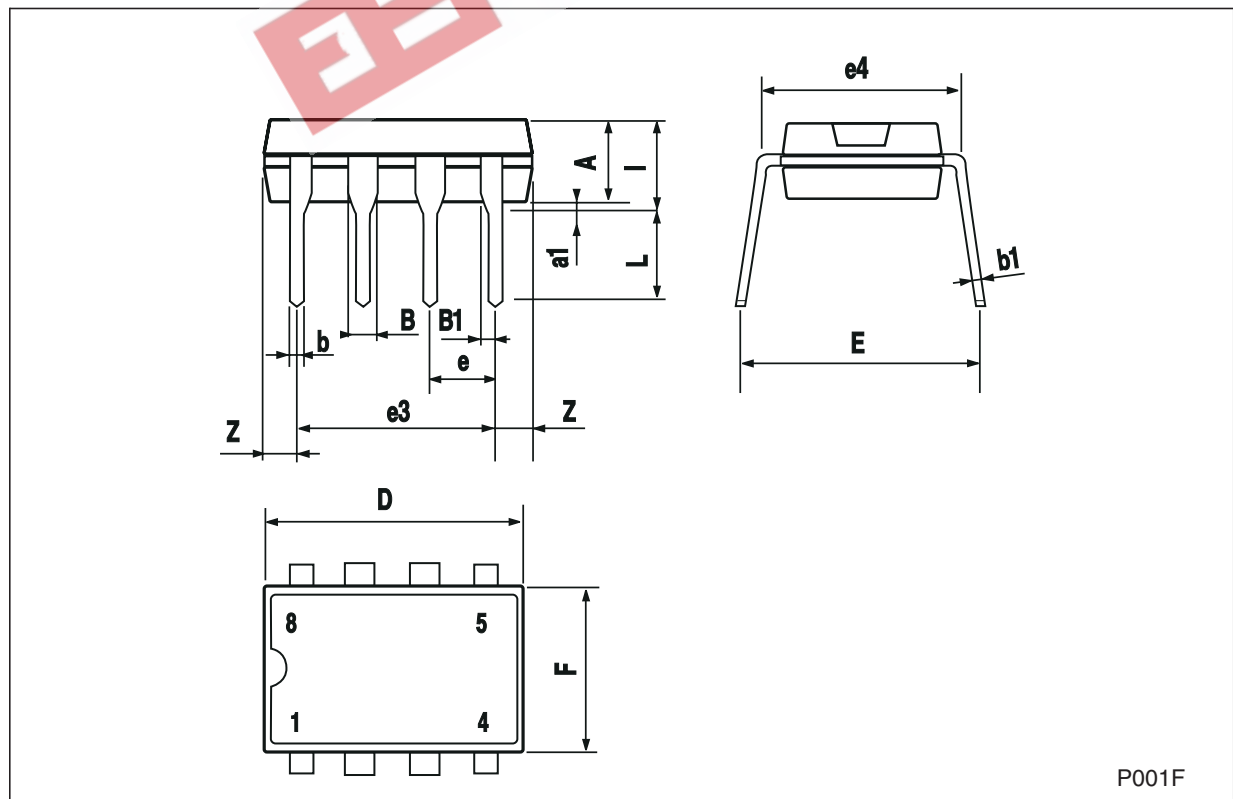

P001F

SO-8 mechanical data

Dim.	mm.			inch.		
	Min.	Typ.	Max.	Min.	Typ.	Max.
A	1.35		1.75	0.053		0.069
A1	0.10		0.25	0.04		0.010
A2	1.10		1.65	0.043		0.065
B	0.33		0.51	0.013		0.020
C	0.19		0.25	0.007		0.010
D	4.80		5.00	0.189		0.197
E	3.80		4.00	0.150		0.157
e		1.27			0.050	
H	5.80		6.20	0.228		0.244
h	0.25		0.50	0.010		0.020
L	0.40		1.27	0.016		0.050
k	8° (max.)					
ddd			0.1			0.04

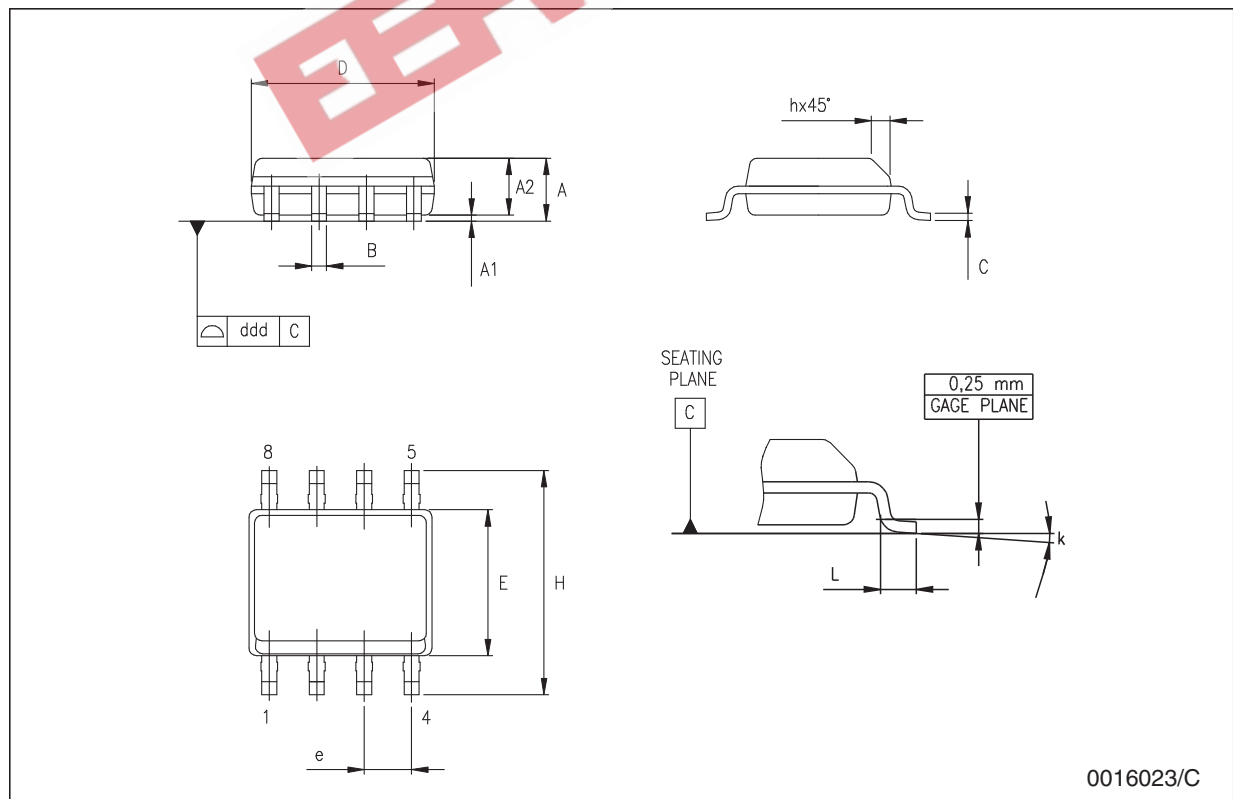

0016023/C

Tape & reel SO-8 mechanical data

Dim.	mm.			inch.		
	Min.	Typ.	Max.	Min.	Typ.	Max.
A			330			12.992
C	12.8		13.2	0.504		0.519
D	20.2			0.795		
N	60			2.362		
T			22.4			0.882
Ao	8.1		8.5	0.319		0.335
Bo	5.5		5.9	0.216		0.232
Ko	2.1		2.3	0.082		0.090
Po	3.9		4.1	0.153		0.161
P	7.9		8.1	0.311		0.319

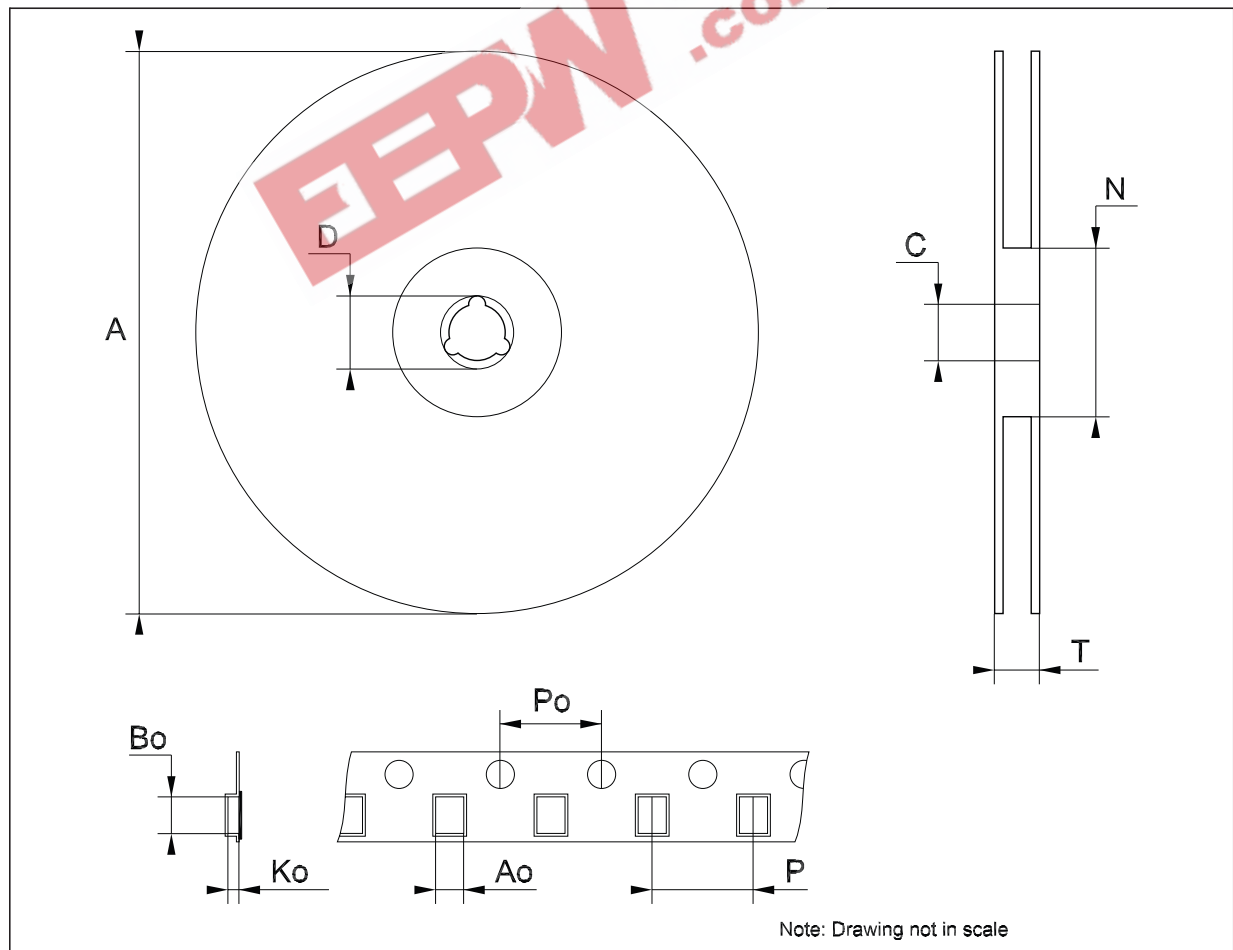

Note: Drawing not in scale

8 Revision history

Table 13. Document revision history

Date	Revision	Changes
22-Jun-2004	9	
20-Nov-2007	10	Added Table 1 .

EEPW 电子产品世界
.com.cn

Please Read Carefully:

Information in this document is provided solely in connection with ST products. STMicroelectronics NV and its subsidiaries ("ST") reserve the right to make changes, corrections, modifications or improvements, to this document, and the products and services described herein at any time, without notice.

All ST products are sold pursuant to ST's terms and conditions of sale.

Purchasers are solely responsible for the choice, selection and use of the ST products and services described herein, and ST assumes no liability whatsoever relating to the choice, selection or use of the ST products and services described herein.

No license, express or implied, by estoppel or otherwise, to any intellectual property rights is granted under this document. If any part of this document refers to any third party products or services it shall not be deemed a license grant by ST for the use of such third party products or services, or any intellectual property contained therein or considered as a warranty covering the use in any manner whatsoever of such third party products or services or any intellectual property contained therein.

UNLESS OTHERWISE SET FORTH IN ST'S TERMS AND CONDITIONS OF SALE ST DISCLAIMS ANY EXPRESS OR IMPLIED WARRANTY WITH RESPECT TO THE USE AND/OR SALE OF ST PRODUCTS INCLUDING WITHOUT LIMITATION IMPLIED WARRANTIES OF MERCHANTABILITY, FITNESS FOR A PARTICULAR PURPOSE (AND THEIR EQUIVALENTS UNDER THE LAWS OF ANY JURISDICTION), OR INFRINGEMENT OF ANY PATENT, COPYRIGHT OR OTHER INTELLECTUAL PROPERTY RIGHT.

UNLESS EXPRESSLY APPROVED IN WRITING BY AN AUTHORIZED ST REPRESENTATIVE, ST PRODUCTS ARE NOT RECOMMENDED, AUTHORIZED OR WARRANTED FOR USE IN MILITARY, AIR CRAFT, SPACE, LIFE SAVING, OR LIFE SUSTAINING APPLICATIONS, NOR IN PRODUCTS OR SYSTEMS WHERE FAILURE OR MALFUNCTION MAY RESULT IN PERSONAL INJURY, DEATH, OR SEVERE PROPERTY OR ENVIRONMENTAL DAMAGE. ST PRODUCTS WHICH ARE NOT SPECIFIED AS "AUTOMOTIVE GRADE" MAY ONLY BE USED IN AUTOMOTIVE APPLICATIONS AT USER'S OWN RISK.

Resale of ST products with provisions different from the statements and/or technical features set forth in this document shall immediately void any warranty granted by ST for the ST product or service described herein and shall not create or extend in any manner whatsoever, any liability of ST.

ST and the ST logo are trademarks or registered trademarks of ST in various countries.

Information in this document supersedes and replaces all information previously supplied.

The ST logo is a registered trademark of STMicroelectronics. All other names are the property of their respective owners.

© 2007 STMicroelectronics - All rights reserved

STMicroelectronics group of companies

Australia - Belgium - Brazil - Canada - China - Czech Republic - Finland - France - Germany - Hong Kong - India - Israel - Italy - Japan - Malaysia - Malta - Morocco - Singapore - Spain - Sweden - Switzerland - United Kingdom - United States of America

www.st.com