



Quad Line Driver with Three-State Outputs

Motorola's Quad EIA-422 Driver features four independent driver chains which comply with EIA Standards for the Electrical Characteristics of Balanced Voltage Digital Interface Circuits. The outputs are three-state structures which are forced to a high impedance state when the appropriate output control pin reaches a logic zero condition. All input pins are PNP buffered to minimize input loading for either logic one or logic zero inputs. In addition, internal circuitry assures a high impedance output state during the transition between power up and power down. A summary of MC3487 features include:

- Four Independent Driver Chains
- Three-State Outputs
- PNP High Impedance Inputs (PIA Compatible)
- Fast Propagation Times (Typical 15 ns)
- TTL Compatible
- Single 5.0 V Supply Voltage
- Output Rise and Fall Times Less Than 20 ns
- DS 3487 Provides Second Source

MC3487

QUAD EIA-422 LINE DRIVER WITH THREE-STATE OUTPUTS

SEMICONDUCTOR TECHNICAL DATA

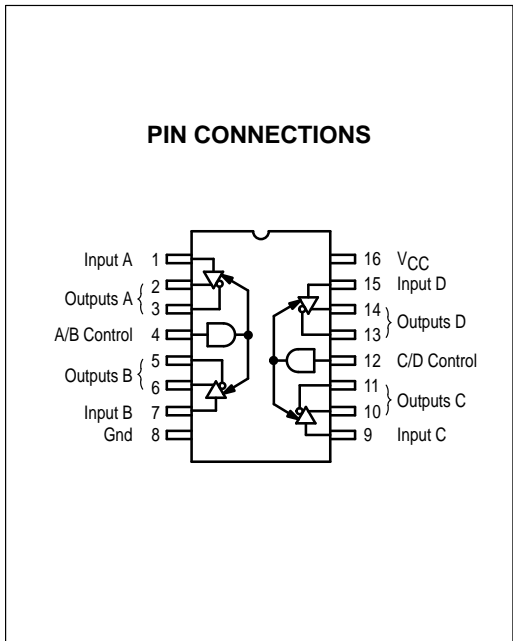
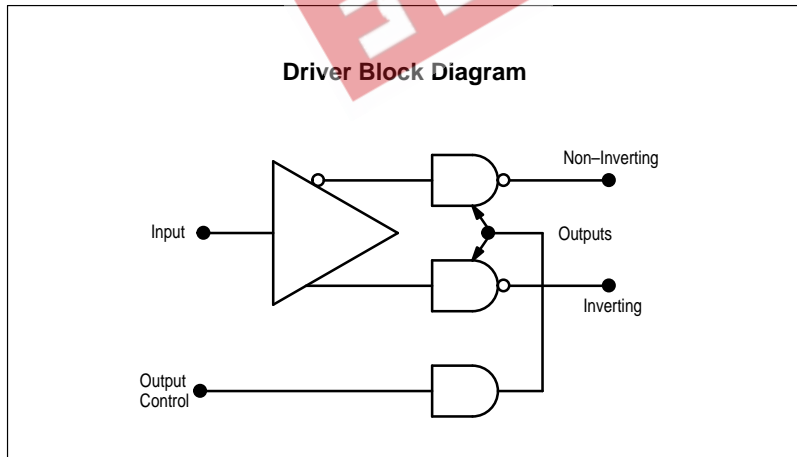
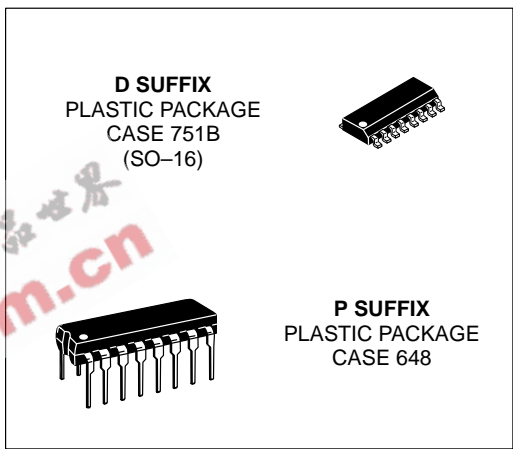

TRUTH TABLE

Input	Control Input	Non-Inverting Output	Inverting Output
H	H	H	L
L	H	L	H
X	L	Z	Z

L = Low Logic State
 H = High Logic State
 X = Irrelevant
 Z = Third-State (High Impedance)

ORDERING INFORMATION

Device	Operating Temperature Range	Package
MC3487P	$T_A = 0 \text{ to } +70^\circ\text{C}$	Plastic DIP
MC3487D		SO-16

MC3487

MAXIMUM RATINGS

Rating	Symbol	Value	Unit
Power Supply Voltage	V_{CC}	8.0	Vdc
Input Voltage	V_I	5.5	Vdc
Operating Ambient Temperature Range	T_A	0 to +70	°C
Operating Junction Temperature Range	T_J	150	°C
Storage Temperature Range	T_{stg}	-65 to +150	°C

ELECTRICAL CHARACTERISTICS (Unless otherwise noted, specifications apply $4.75\text{ V} \leq V_{CC} \leq 5.25\text{ V}$ and $0^\circ\text{C} \leq T_A \leq 70^\circ\text{C}$. Typical values measured at $V_{CC} = 5.0\text{ V}$, and $T_A = 25^\circ\text{C}$.)

Characteristic	Symbol	Min	Typ	Max	Unit
Input Voltage – Low Logic State	V_{IL}	–	–	0.8	Vdc
Input Voltage – High Logic State	V_{IH}	2.0	–	–	Vdc
Input Current – Low Logic State ($V_{IL} = 0.5\text{ V}$)	I_{IL}	–	–	– 400	μA
Input Current – High Logic State ($V_{IH} = 2.7\text{ V}$) ($V_{IH} = 5.5\text{ V}$)	I_{IH}	– –	– –	+ 50 + 100	μA
Input Clamp Voltage ($I_{IK} = -18\text{ mA}$)	V_{IK}	–	–	– 1.5	V
Output Voltage – Low Logic State ($I_{OL} = 48\text{ mA}$)	V_{OL}	–	–	0.5	V
Output Voltage – High Logic State ($I_{OH} = -20\text{ mA}$)	V_{OH}	2.5	–	–	V
Output Short-Circuit Current ($V_{IH} = 2.0\text{ V}$, Note 1)	I_{OS}	– 40	–	– 140	mA
Output Leakage Current – Hi-Z State ($V_{IL} = 0.5\text{ V}$, $V_{IL(Z)} = 0.8\text{ V}$) ($V_{IH} = 2.7\text{ V}$, $V_{IL(Z)} = 0.8\text{ V}$)	$I_{OL(Z)}$	– –	– –	± 100 ± 100	μA
Output Leakage Current – Power OFF ($V_{OH} = 6.0\text{ V}$, $V_{CC} = 0\text{ V}$) ($V_{OL} = -0.25\text{ V}$, $V_{CC} = 0\text{ V}$)	$I_{OL(off)}$	– –	– –	+ 100 – 100	μA
Output Offset Voltage Difference (Note 2)	$V_{OS} - V_{OS}$	–	–	± 0.4	V
Output Differential Voltage (Note 2)	V_{OD}	2.0	–	–	V
Output Differential Voltage Difference (Note 2)	$ \Delta V_{OD} $	–	–	± 0.4	V
Power Supply Current (Control Pins = Gnd, Note 3) (Control Pins = 2.0 V)	I_{CCX} I_{CC}	– –	– –	105 85	mA

- NOTES:**
 1. Only one output may be shorted at a time.
 2. See EIA Specification EIA-422 for exact test conditions.
 3. Circuit in three-state condition.

SWITCHING CHARACTERISTICS ($V_{CC} = 5.0\text{ V}$, $T_A = 25^\circ\text{C}$, unless otherwise noted.)

Characteristic	Symbol	Min	Typ	Max	Unit
Propagation Delay Times High to Low Output Low to High Output	t_{PHL} t_{PLH}	– –	– –	20 20	ns
Output Transition Times – Differential High to Low Output Low to High Output	t_{THL} t_{TLH}	– –	– –	20 20	ns
Propagation Delay – Control to Output ($R_L = 200\ \Omega$, $C_L = 50\text{ pF}$) ($R_L = 200\ \Omega$, $C_L = 50\text{ pF}$) ($R_L = \infty$, $C_L = 50\text{ pF}$) ($R_L = 200\ \Omega$, $C_L = 50\text{ pF}$)	$t_{PHZ(E)}$ $t_{PLZ(E)}$ $t_{PZH(E)}$ $t_{PZL(E)}$	– – – –	– – – –	25 25 30 30	ns

MC3487

Figure 1. Three-State Enable Test Circuit and Waveforms

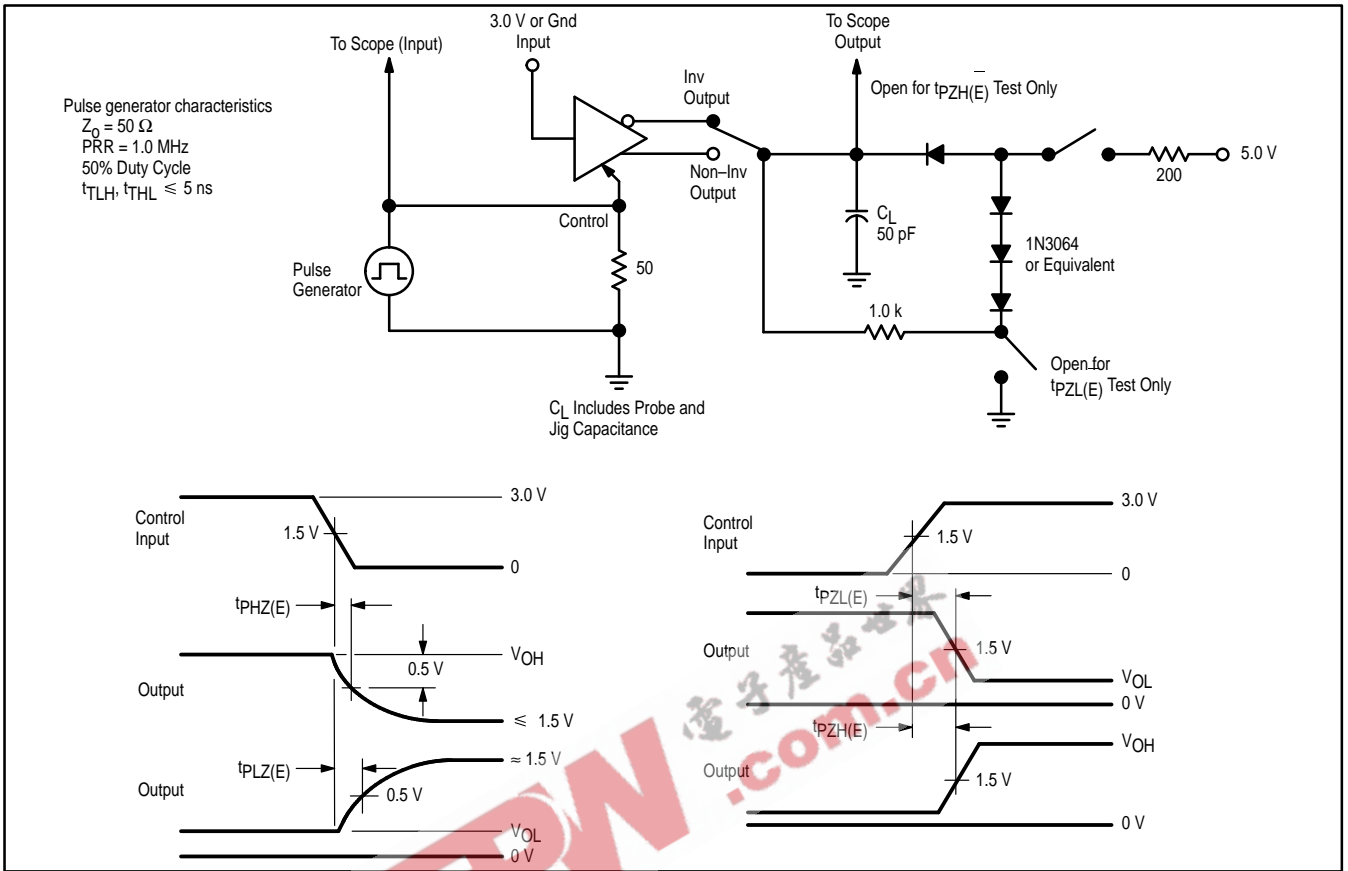
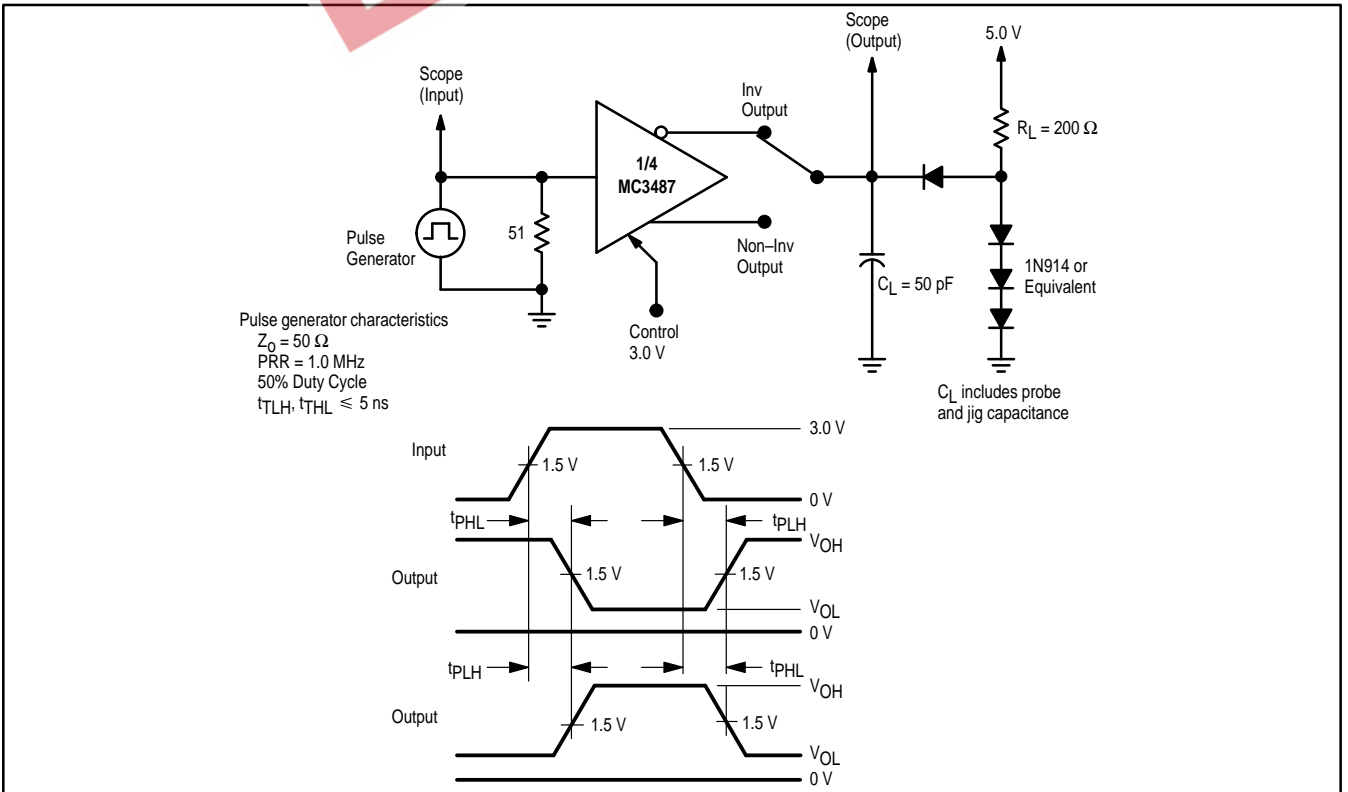

Figure 2. Propagation Delay Times Input to Output Waveforms and Test Circuit



MC3487

Figure 3. Output Transition Times Test Circuit and Waveforms

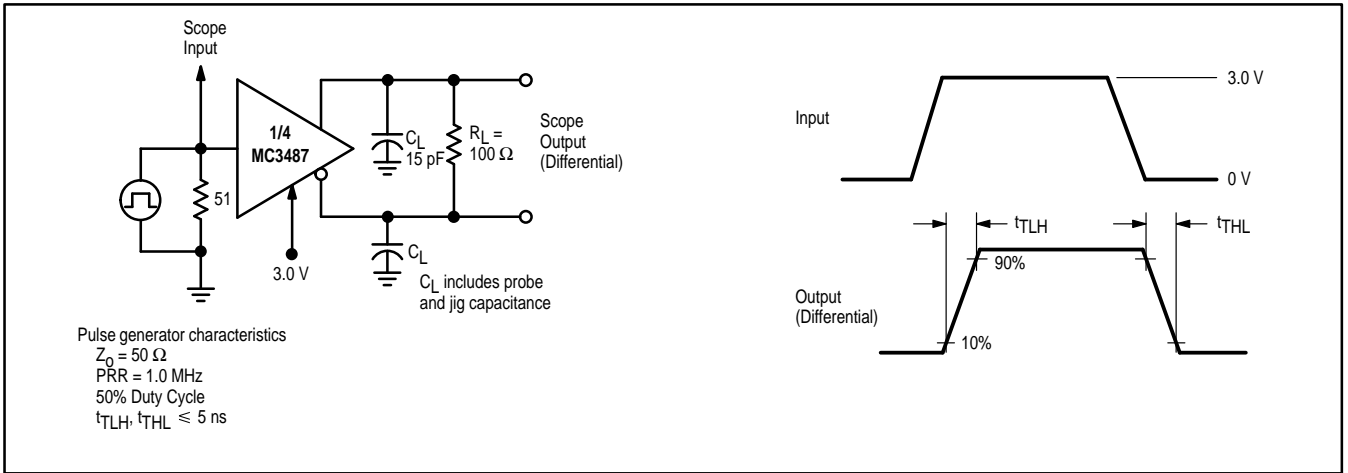

Figure 4. Output Current versus Output Voltage

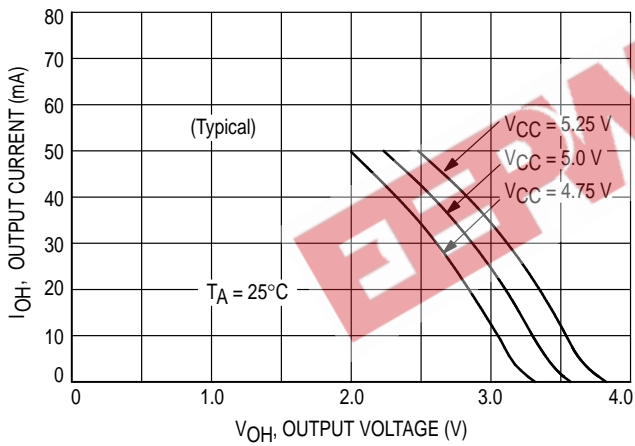
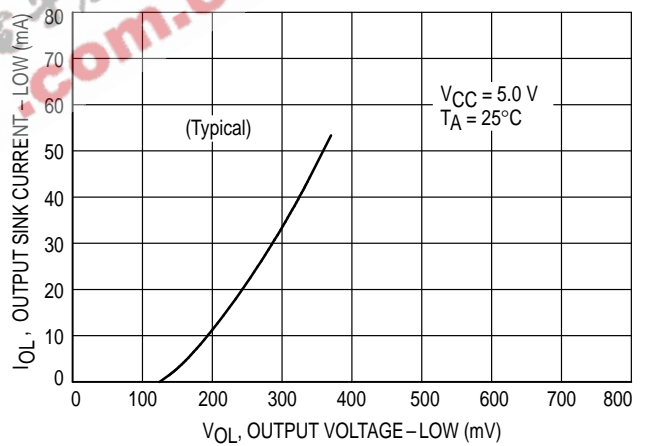

Figure 5. Output Sink Current versus Output Voltage



MC3487

OUTLINE DIMENSIONS

D SUFFIX PLASTIC PACKAGE CASE 751B-05 (SO-16) ISSUE J

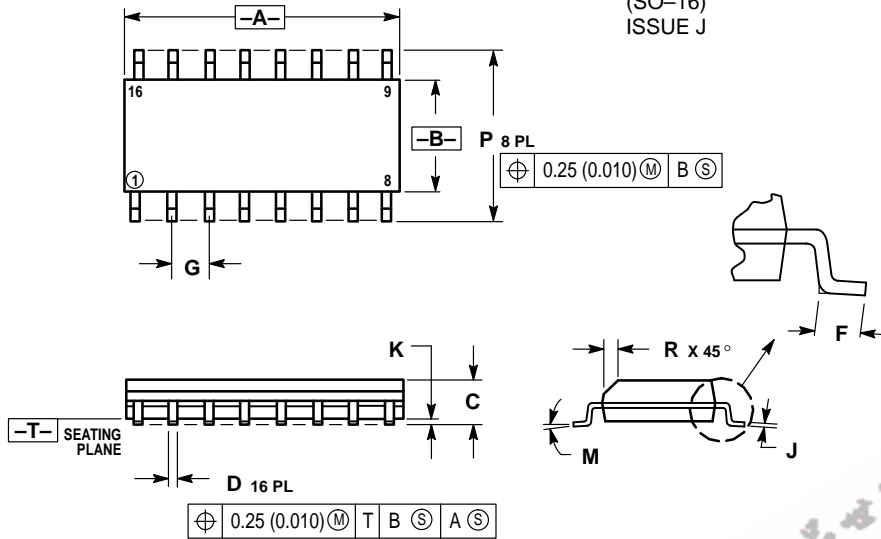

NOTES:

1. DIMENSIONING AND TOLERANCING PER ANSI Y14.5M, 1982.
2. CONTROLLING DIMENSION: MILLIMETER.
3. DIMENSIONS A AND B DO NOT INCLUDE MOLD PROTRUSION.
4. MAXIMUM MOLD PROTRUSION 0.15 (0.006) PER SIDE.
5. DIMENSION D DOES NOT INCLUDE DAMBAR PROTRUSION. ALLOWABLE DAMBAR PROTRUSION SHALL BE 0.127 (0.005) TOTAL IN EXCESS OF THE D DIMENSION AT MAXIMUM MATERIAL CONDITION.

DIM	MILLIMETERS		INCHES	
	MIN	MAX	MIN	MAX
A	9.80	10.00	0.386	0.393
B	3.80	4.00	0.150	0.157
C	1.35	1.75	0.054	0.068
D	0.35	0.49	0.014	0.019
F	0.40	1.25	0.016	0.049
G	1.27 BSC		0.050 BSC	
J	0.19	0.25	0.008	0.009
K	0.10	0.25	0.004	0.009
M	0°	7°	0°	7°
P	5.80	6.20	0.229	0.244
R	0.25	0.50	0.010	0.019

P SUFFIX PLASTIC PACKAGE CASE 648-08 ISSUE R

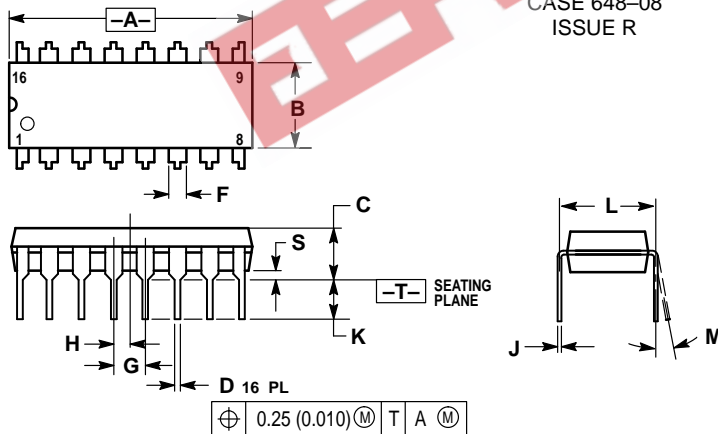

NOTES:

1. DIMENSIONING AND TOLERANCING PER ANSI Y14.5M, 1982.
2. CONTROLLING DIMENSION: INCH.
3. DIMENSION L TO CENTER OF LEADS WHEN FORMED PARALLEL.
4. DIMENSION B DOES NOT INCLUDE MOLD FLASH.
5. ROUNDED CORNERS OPTIONAL.

DIM	INCHES		MILLIMETERS	
	MIN	MAX	MIN	MAX
A	0.740	0.770	18.80	19.55
B	0.250	0.270	6.35	6.85
C	0.145	0.175	3.69	4.44
D	0.015	0.021	0.39	0.53
F	0.040	0.70	1.02	1.77
G	0.100 BSC		2.54 BSC	
H	0.050 BSC		1.27 BSC	
J	0.008	0.015	0.21	0.38
K	0.110	0.130	2.80	3.30
L	0.295	0.305	7.50	7.74
M	0°	10°	0°	10°
S	0.020	0.040	0.51	1.01

MC3487

EEPW 电子产品世界
.com.cn

Motorola reserves the right to make changes without further notice to any products herein. Motorola makes no warranty, representation or guarantee regarding the suitability of its products for any particular purpose, nor does Motorola assume any liability arising out of the application or use of any product or circuit, and specifically disclaims any and all liability, including without limitation consequential or incidental damages. "Typical" parameters can and do vary in different applications. All operating parameters, including "Typicals" must be validated for each customer application by customer's technical experts. Motorola does not convey any license under its patent rights nor the rights of others. Motorola products are not designed, intended, or authorized for use as components in systems intended for surgical implant into the body, or other applications intended to support or sustain life, or for any other application in which the failure of the Motorola product could create a situation where personal injury or death may occur. Should Buyer purchase or use Motorola products for any such unintended or unauthorized application, Buyer shall indemnify and hold Motorola and its officers, employees, subsidiaries, affiliates, and distributors harmless against all claims, costs, damages, and expenses, and reasonable attorney fees arising out of, directly or indirectly, any claim of personal injury or death associated with such unintended or unauthorized use, even if such claim alleges that Motorola was negligent regarding the design or manufacture of the part. Motorola and  are registered trademarks of Motorola, Inc. Motorola, Inc. is an Equal Opportunity/Affirmative Action Employer.

How to reach us:

USA / EUROPE: Motorola Literature Distribution;
P.O. Box 20912; Phoenix, Arizona 85036. 1-800-441-2447

JAPAN: Nippon Motorola Ltd.; Tatsumi-SPD-JLDC, Toshikatsu Otsuki,
6F Seibu-Butsuryu-Center, 3-14-2 Tatsumi Koto-Ku, Tokyo 135, Japan. 03-3521-8315

MFAX: RMFAX0@email.sps.mot.com – TOUCHTONE (602) 244-6609
INTERNET: <http://Design-NET.com>

HONG KONG: Motorola Semiconductors H.K. Ltd.; 8B Tai Ping Industrial Park,
51 Ting Kok Road, Tai Po, N.T., Hong Kong. 852-26629298



MC3487/D

