

#### Legacy Device: Motorola MC33111

The ML33111 contains two variable gain circuits configured for compressing and expanding the dynamic range of an audio signal. One circuit is configured as an expander, and the other is configured as a compressor. Each circuit has a full wave rectifier to provide average value information to a variable gain cell located in either the input stage or the feedback path. An internal temperature stable bandgap reference provides the necessary precision voltages.

Included in the ML33111 are controls for muting each section independently, and for pass through of both. Two uncommitted op amps are available for peripheral functions.

The ML33111 will operate from a supply voltage of 3.0 V to 7.0 V, and over a temperature range of  $T_A$   $-40^\circ$  to  $+85^\circ\text{C}$ . It is designed to accommodate a 60 dB dynamic range; from  $-40$  dB to  $+20$  dB referenced to 100 mVrms.

Applications include cordless telephone, CBs, walkie-talkies, and most voice RF links, and any application where an improvement in the signal to noise ratio is desired. Other applications include speakerphones and voice activated intercoms, dictating machines, etc.

- Operating Supply Voltage: 3.0 V to 7.0 V
- Output Voltage Swing = 2.8 Vp-p with  $V_{CC} = 3.0$  V
- No Precision External Components Required
- 60 dB Dynamic Range Compressed to 30 dB, Re-expandable to 60 dB
- Unity Gain Level set at 100 mVrms
- Attack and Decay Times Adjustable
- Mute and passthrough Controls
- Two Uncommitted Op Amps
- Temperature Compensated Reference
- Available in Standard DIP and Surface Mount Packages

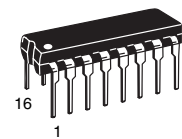
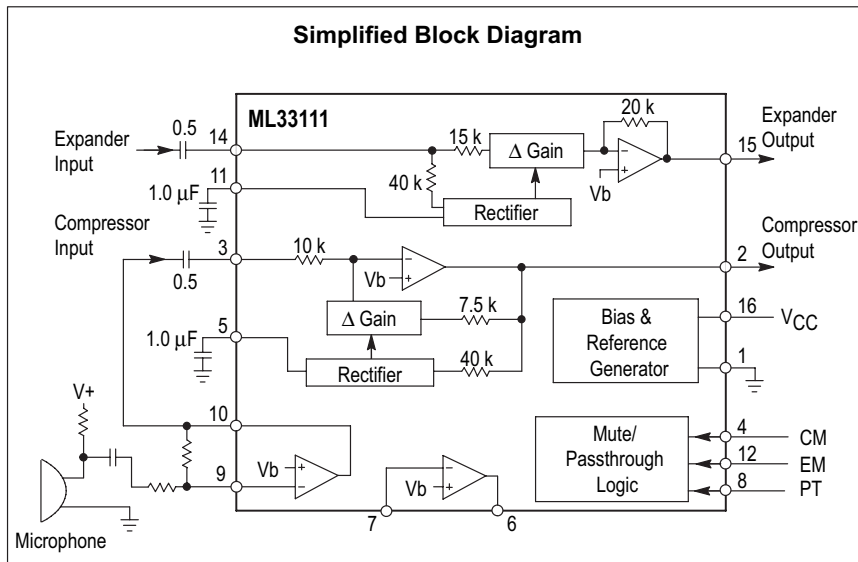

P DIP 16 = EP  
PLASTIC PACKAGE  
CASE 648

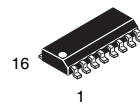

SO 16 = -5P  
PLASTIC PACKAGE  
CASE 751B  
(SO-16)

#### CROSS REFERENCE/ORDERING INFORMATION

PACKAGE	MOTOROLA	LANSDALE
P DIP 16	MC33111P	ML33111EP
SO 16	MC33111D	ML33111-5P

Note: Lansdale lead free (Pb) product, as it becomes available, will be identified by a part number prefix change from ML to MLE.

#### TRUTH TABLE

CM	EM	PT	Function
0	0	0	Normal
1	X	X	Comp. Mute
X	1	X	Expander Mute
0	0	1	Passthrough

## PIN FUNCTION DESCRIPTION

Name	Pin	Description
Ground	1	Connect to a clean power supply ground.
Compressor Output	2	Output of the compressor section.
Compressor Input	3	Compressor input. The input impedance is nominally 10 kΩ. Nominal signal range is 1.0 mVrms to 1.0 Vrms in normal mode, and up to 0.8 Vrms in passthrough mode. Must be capacitor coupled to the signal source.
Compressor Mute	4	A logic high mutes the compressor. A logic low permits normal operation and passthrough.
Compressor Filter	5	Connect an external capacitor to filter the full wave rectifier's output. This capacitor affects attack and decay times, and low frequency accuracy.
Amplifier #1	6, 7	Inverting input (7) and output (6) of an op amp internally referenced to Vb.
Passthrough	8	A logic high sets the gain of both expander and compressor to ≈ 0 dB, independent of input level.
Amplifier #2	9, 10	Inverting input (9) and output (10) of an op amp internally referenced to Vb.
Expander Filter	11	Connect an external capacitor to filter the full wave rectifier's output. This capacitor affects attack and decay times, and low frequency accuracy.
Expander Mute	12	A logic high mutes the expander. A logic low permits normal operation and passthrough.
No Connect	13	This pin is not internally connected to anything.
Expander Input	14	Expander input. The input impedance is nominally 10.9 kΩ. Nominal signal range is 10 mVrms to 316 mVrms in normal mode, and up to 1.0 Vrms in passthrough mode. Must be capacitor coupled to the signal source.
Expander Output	15	Output of the expander section.
V <sub>CC</sub>	16	Power supply. Connect to a power supply voltage in the range of 3.0 V to 7.0 V. Bypass capacitor should be provided at this pin.

## TRANSFER FUNCTIONS

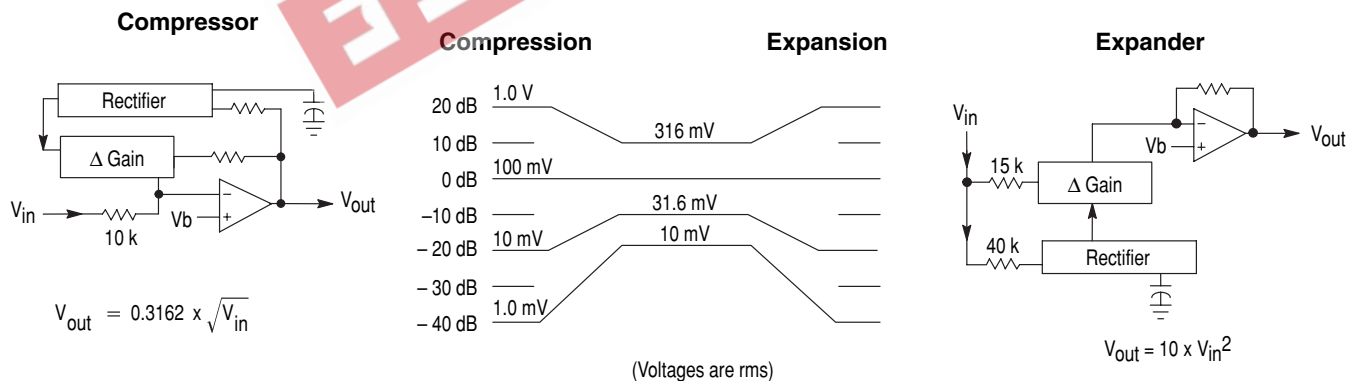

## MAXIMUM RATINGS

Rating	Symbol	Value	Unit
V <sub>CC</sub> Supply Voltage (Pin 16 – Pin 1)	V <sub>CC</sub>	-0.5, +12	Vdc
High Input Voltage (Pins 3, 4, 8, 12, 14)	V <sub>IH</sub>	V <sub>CC</sub> + 0.5	Vdc
Low Input Voltage (Pins 3, 4, 8, 12, 14)	V <sub>IL</sub>	-0.5	Vdc
Output Source Current (Pins 2, 6, 10, 15)	IO+	Self-limiting	mA
Output Sink Current (Pins 2, 6, 10, 15)	IO-	Self-limiting	mA
Storage Temperature	T <sub>stg</sub>	-65, +150	°C

**NOTE:** Devices should not be operated at these limits. The "Recommended Operating Conditions" provides for actual device operation.

## RECOMMENDED OPERATING CONDITIONS

Characteristic	Symbol	Min	Typ	Max	Unit
V <sub>CC</sub> Supply Voltage	V <sub>CC</sub>	3.0	—	7.0	Vdc
Input Signal Voltage Range (3.0 V < V <sub>CC</sub> < 7.0 V)	V <sub>in</sub>				Vrms
Compressor — Normal and Mute Mode		0	—	1.3	
— Passthrough Mode		0	—	0.8	
Expander — Normal Mode		0	—	0.32	
— Mute Mode		0	—	1.3	
— Passthrough Mode		0	—	1.0	
Frequency Range (± 1.0 dB accuracy)	F <sub>in</sub>	0.300	—	10	kHz
Logic Input Voltage Range (Pins 4, 8, 12)	V <sub>in</sub>	0	—	V <sub>CC</sub>	Vdc
Operating Ambient Temperature	T <sub>A</sub>	-40	—	+85	°C

NOTE: All limits are not necessarily functional concurrently.

ELECTRICAL CHARACTERISTICS (V<sub>CC</sub> = 3.6 V, f = 1.0 kHz, T<sub>A</sub> = +25°C, unless noted.)

Characteristic	Symbol	Min	Typ	Max	Unit
<b>COMPRESSOR</b> (Pin 4 = Low unless noted)					
0 dB Gain (V <sub>in</sub> = 100 mVrms)	G <sub>OC</sub>	-1.5	0	1.5	dB
Gain tracking relative to G <sub>OC</sub>	G <sub>TC</sub>				dB
V <sub>in</sub> = 1.0 Vrms		9.0	10	11	
V <sub>in</sub> = 1.0 mVrms		-21	-20	-19	
Passthrough Gain (Pin 8 = High, Pin 4 = Low, V <sub>in</sub> = 1.0 Vrms)	G <sub>PTC</sub>	-2.0	0	1.0	dB
Muting (Δ Gain) with Pin 4 = High (V <sub>in</sub> = 1.0 Vrms)	G <sub>MTC</sub>	55	67	—	dB
Max. Output Swing @ Pin 2 (3.0 V < V <sub>CC</sub> < 7.0 V)	V <sub>out</sub>				V <sub>p-p</sub>
Normal Mode		—	1.1	—	
Passthrough Mode		—	2.3	—	
Peak Output Current (3.0 ≤ V <sub>CC</sub> ≤ 7.0 V, Normal or Passthrough Modes, V <sub>in</sub> = Max)	I <sub>PK</sub>	—	±4.0	—	mA
Total Harmonic Distortion (V <sub>in</sub> = 100 mVrms)	THD	—	0.2	1.0	%
Power Supply Rejection @ 1.0 KHz	PSRR				dB
V <sub>in</sub> (Pin 3) = 0		—	37	—	
V <sub>in</sub> (Pin 3) = 10 mVrms		—	64	—	
V <sub>in</sub> (Pin 3) = 1.0 Vrms		—	72	—	
Attack Time (Capacitor @ Pin 5 = 1.0 μF, per EIA-553)	t <sub>AT(C)</sub>	—	3.0	—	ms
Decay Time (Capacitor @ Pin 5 = 1.0 μF, per EIA-553)	t <sub>D(C)</sub>	—	14	—	
Input Impedance at Pin 3	R <sub>in</sub>	8.0	10	14	kΩ
DC Bias Level (Pin 2)	V <sub>bIAS</sub>	1.4	V <sub>b</sub>	1.6	Vdc
Output DC Shift (V <sub>in</sub> Changed from 0 to 100 mVrms)		-20	1.6	2.0	mVdc

## EXPANDER (Pin 12 = Low, unless noted)

0 dB Gain (V <sub>in</sub> = 100 mVrms)	G <sub>OE</sub>	-1.5	0	1.5	dB
Gain Tracking Relative to G <sub>OE</sub>	G <sub>TE</sub>				dB
V <sub>in</sub> = 316 mVrms		19	20	21	
V <sub>in</sub> = 10 mVrms		-41	-40	-39	
Passthrough Gain (Pin 8 = High, Pin 12 = Low, V <sub>in</sub> = 1.0 Vrms)	G <sub>PTE</sub>	-1.0	0	2.0	dB
Muting (Δ Gain) with Pin 12 = High (V <sub>in</sub> = 0.316 Vrms)	G <sub>MTE</sub>	60	76	—	dB
Max. Output Swing @ Pin 15 (3.0 V < V <sub>CC</sub> < 7.0 V)	V <sub>out</sub>				V <sub>p-p</sub>
Normal Mode		—	2.8	—	
Passthrough Mode		—	2.8	—	
Peak Output Current	I <sub>PK</sub>				mA
V <sub>CC</sub> = 3.0 V, V <sub>out</sub> ≤ 2.4 V <sub>p-p</sub>		—	±3.5	—	
V <sub>CC</sub> = 3.0 V, V <sub>out</sub> = 2.7 V <sub>p-p</sub>		—	±1.0	—	
V <sub>CC</sub> ≥ 3.6 V, V <sub>out</sub> ≤ 2.8 V <sub>p-p</sub>		—	±4.0	—	
Total Harmonic Distortion (V <sub>in</sub> = 100 mVrms)	THD	—	0.2	1.0	%

**ELECTRICAL CHARACTERISTICS** ( $V_{CC} = 3.6\text{ V}$ ,  $f = 1.0\text{ kHz}$ ,  $T_A = +25^\circ\text{C}$ , unless noted.)

Characteristic	Symbol	Min	Typ	Max	Unit
<b>EXPANDER</b> (Pin 12 = Low, unless noted)					
Power Supply Rejection @ 1.0 kHz $V_{in}$ (Pin 14) = 0 $V_{in}$ (Pin 14) = 10 mVrms $V_{in}$ (Pin 14) = 316 mVrms	PSRR	— — —	74 76 62	— — —	dB
Attack Time (Capacitor @ Pin 11 = 1.0 $\mu\text{F}$ , per EIA-553) Decay Time (Capacitor @ Pin 11 = 1.0 $\mu\text{F}$ , per EIA-553)	$t_{AT(E)}$ $t_{D(E)}$	— —	3.0 14	— —	ms
Input Impedance at Pin 14	$R_{in}$	8.0	10.9	14	$\text{k}\Omega$
DC Bias Level (Pin 15) Output DC Shift ( $V_{in}$ changed from 0 to 100 mVrms)	$V_{bIAS}$	1.4 -20	$V_b$ 1.0	1.6 20	Vdc mVdc
<b>LOGIC INPUTS</b> (Pins 4, 8, 12)					
Switching Threshold ( $3.0 < V_{CC} < 7.0\text{ V}$ )	$V_{ST}$	—	1.3	—	Vdc
Input Current @ $V_{in} = 0\text{ V}$ @ $V_{in} = 3.6\text{ V}$	$R_{in}$	— —	0 55	— —	$\mu\text{A}$
Timing ( $V_{in}$ @ Pins 3 and 14 = 300 mVrms, See Figures 1, 2)					$\mu\text{s}$
Comp. Mute (Pin 4) to Comp. Output	Low-to-High	—	2.0	—	
	High-to-Low	—	3.0	—	
Exp. Mute (Pin 12) to Exp. Output	Low-to-High	—	2.0	—	
	High-to-Low	—	3.0	—	
Passthrough (Pin 8) to Comp. Output	Low-to-High	—	2.0	—	
	High-to-Low	—	5.0	—	
Passthrough (Pin 8) to Exp. Output	Low-to-High	—	6.0	—	
	High-to-Low	—	7.0	—	
<b>OP AMPS</b> (Pins 6, 7, 9, 10)					
Open Loop Gain	$A_{VOL}$	—	100	—	dB
Gain Bandwidth	BW	—	300	—	kHz
Input Bias Current @ Pins 7, 9	$I_{IB}$	—	8.0	—	nA
Max Output Swing @ Pins 6, 10 ( $3.0\text{ V} < V_{CC} < 7.0\text{ V}$ )	$V_{out}$	—	2.8	—	$V_{p-p}$
Peak Output Current $V_{CC} = 3.0\text{ V}$ , $V_{out} \leq 2.4\text{ V}_{p-p}$ $V_{CC} = 3.0\text{ V}$ , $V_{out} = 2.6\text{ V}_{p-p}$ $V_{CC} \geq 3.6\text{ V}$ , $V_{out} \leq 2.8\text{ V}_{p-p}$	$I_{PK}$	— — —	$\pm 3.0$ $\pm 2.0$ $\pm 3.7$	— — —	mA
Total Harmonic Distortion ( $V_{out} = 1.0\text{ Vrms}$ , Unity Gain)	THD	—	0.02	0.2	%
<b>MISCELLANEOUS</b>					
Power Supply Current @ $V_{CC} = 3.6\text{ V}$ @ $V_{CC} = 7.0\text{ V}$	$I_{CC}$	— —	1.5 1.7	2.0 —	mA
Reference Voltage	$V_b$	—	1.5	—	Vdc
Channel Separation	CS				dB
Expander to Compressor (Pin 14 = 316 mVrms @ 1.0 kHz and Pin 3 = 0 mVrms) (Pin 14 = 100 mVrms (300 Hz < f < 20 kHz), Pin 3 = 100 mVrms @ 1.2 kHz)		40 —	70 96	— —	
	Compressor to Expander (Pin 3 = 1.0 Vrms @ 1.0 kHz and Pin 14 = 0 mVrms) (Pin 3 = 100 mVrms (300 Hz < f < 20 kHz), Pin 14 = 100 mVrms @ 1.2 kHz)	60	100	—	
		—	97	—	

**TEMPERATURE PERFORMANCE** (Typical performance based on device characterization, not guaranteed.)

Characteristic	- 40°C	+25°C	+ 85°C
Power Supply Current @ $V_{CC} = 3.6\text{ V}$ @ $V_{CC} = 7.0\text{ V}$	1.2 mA 1.4 mA	1.5 mA 1.7 mA	1.6 mA 1.9 mA
Reference Voltage ( $V_b$ )	1.495 V	1.5 V	1.505 V
0 dB Gain ( $V_{in} = 100\text{ mVrms}$ ) — Compressor	0.08 dB	0 dB	- 0.04 dB
0 dB Gain ( $V_{in} = 100\text{ mVrms}$ ) — Expander	0.04 dB	0 dB	- 0.03 dB
Total Harmonic Distortion ( $V_{in} = 100\text{ mVrms}$ ) — Compressor	0.3%	0.2%	0.2%
Total Harmonic Distortion ( $V_{in} = 100\text{ mVrms}$ ) — Expander	0.3%	0.2%	0.16%
Gain Tracking Relative to 0 dB Gain — Compressor $V_{in} = 1.0\text{ Vrms}$ $V_{in} = 1.0\text{ mVrms}$	10.8 dB -19.95 dB	10 dB - 20 dB	10 dB - 20.1 dB
Gain Tracking Relative to 0 dB Gain — Expander $V_{in} = 316\text{ mVrms}$ $V_{in} = 10\text{ mVrms}$	18.6 dB - 40.2 dB	20 dB - 40 dB	19.95 dB - 39.9 dB
Muting ( $\Delta$ Gain) with Pin 4 = High ( $V_{in} = 1.0\text{ Vrms}$ ) — Compressor	68 dB	67 dB	66 dB
Muting ( $\Delta$ Gain) with Pin 12 = High ( $V_{in} = 0.316\text{ Vrms}$ ) — Expander	76 dB	76 dB	75 dB

Figure 1. Mute Timing

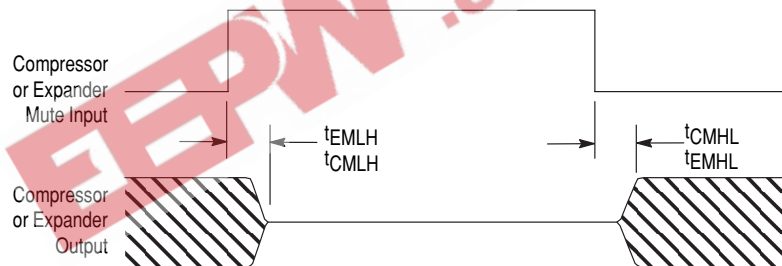

Figure 2. Passthrough Timing

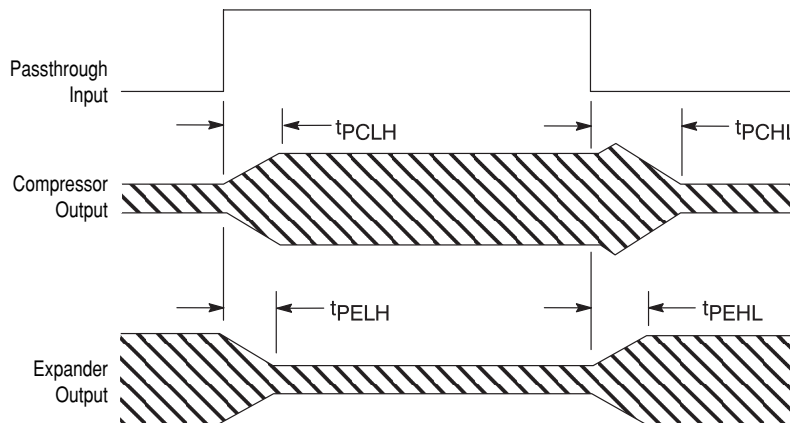

Figure 3. Transfer Characteristics

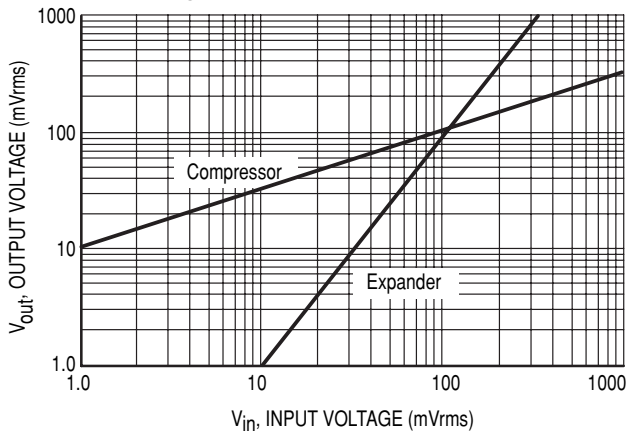

Figure 4. Transfer Characteristics

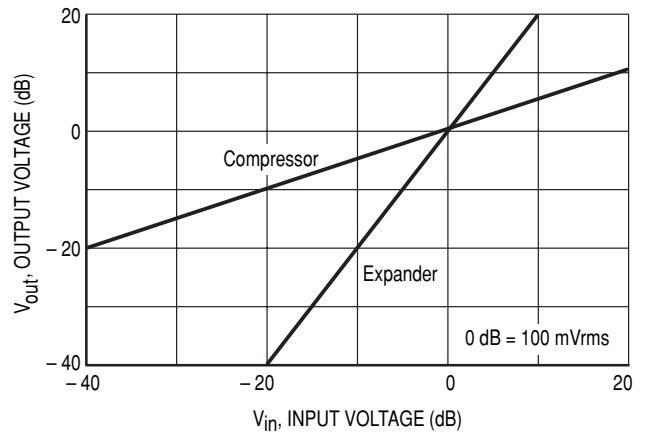

Figure 5. Frequency Response (Compressor)

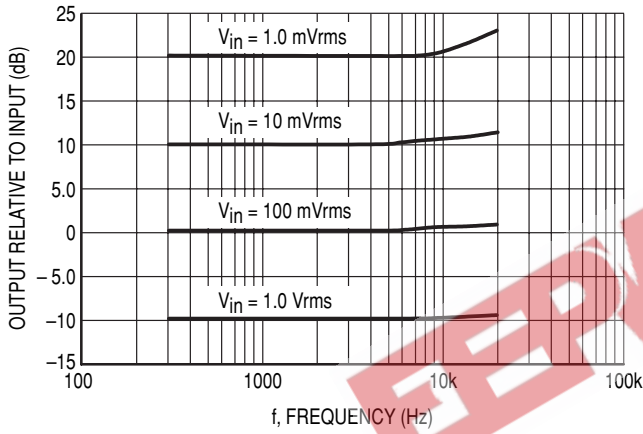

Figure 6. Frequency Response (Expander)

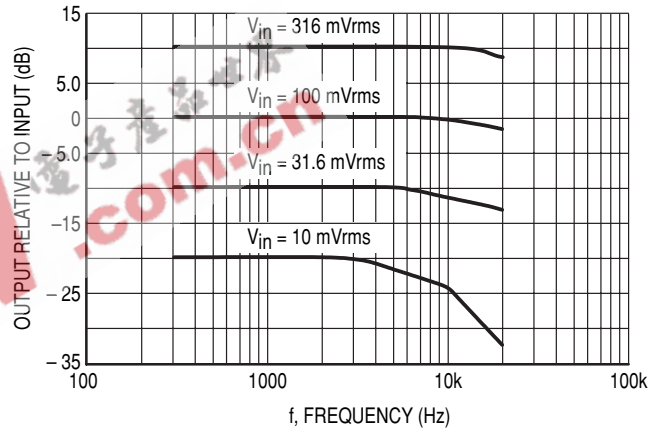
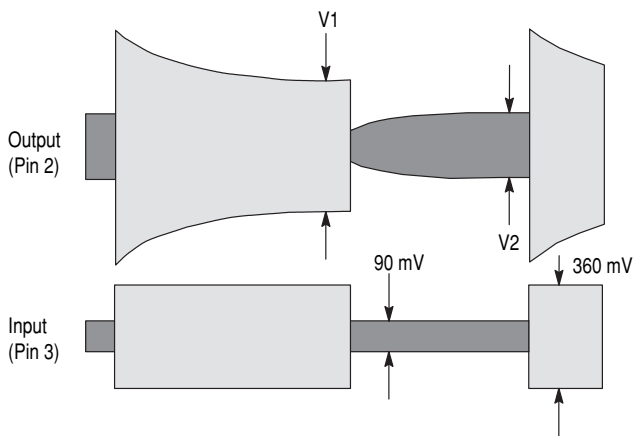
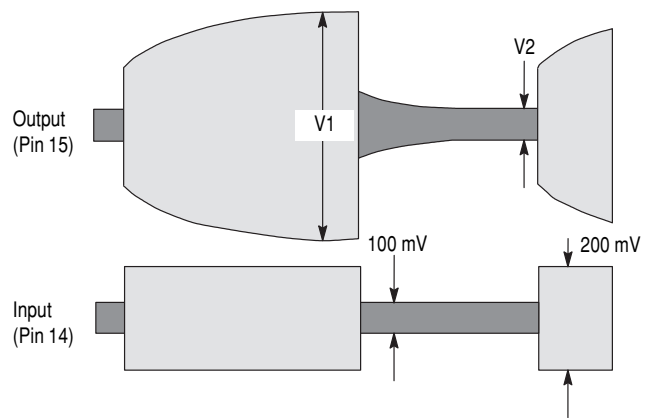

Figure 7. Attack and Decay Times (Compressor)



Attack Time = Time to  $1.5 \times V1$  from input increase.  
 Decay Time = Time to  $0.75 \times V2$  from input decrease.  
 Test per EIA-553.

Figure 8. Attack and Decay Times (Expander)



Attack Time = Time to  $0.57 \times V1$  from input increase.  
 Decay Time = Time to  $1.5 \times V2$  from input decrease.  
 Test per EIA-553.

Figure 9. Attack and Decay Times (Compressor)

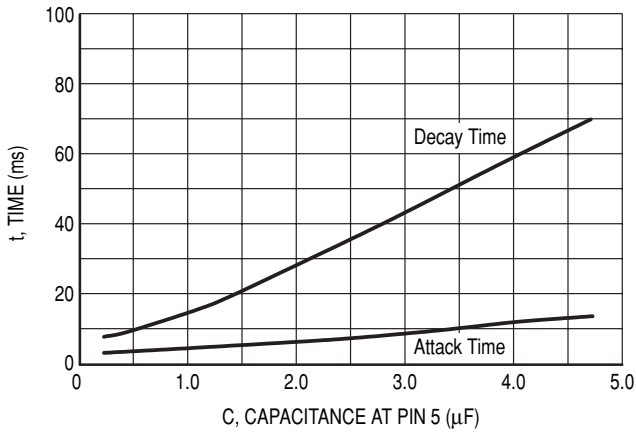

Figure 10. Attack and Decay Times (Expander)

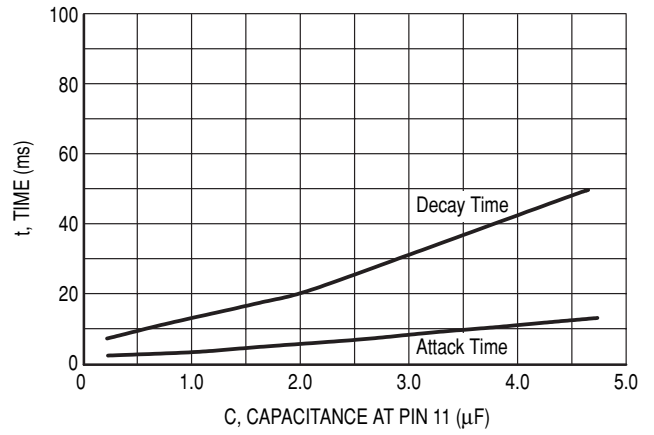

Figure 11. Compressor Gain Tracking versus Temperature

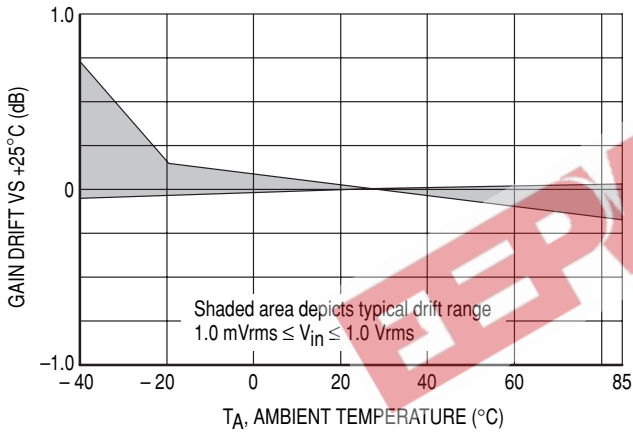

Figure 12. Expander Gain Tracking versus Temperature

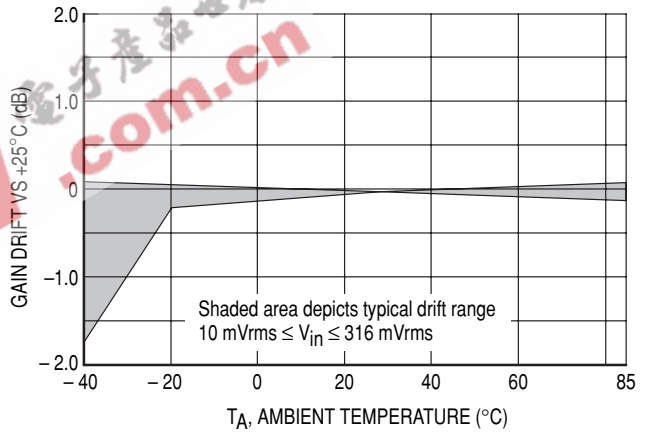

Figure 13. THD versus Temperature

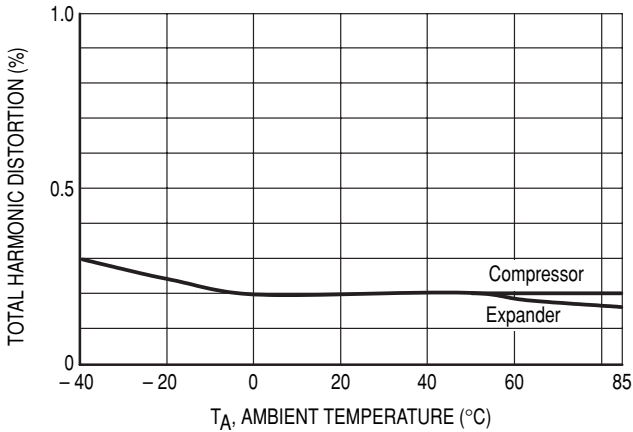
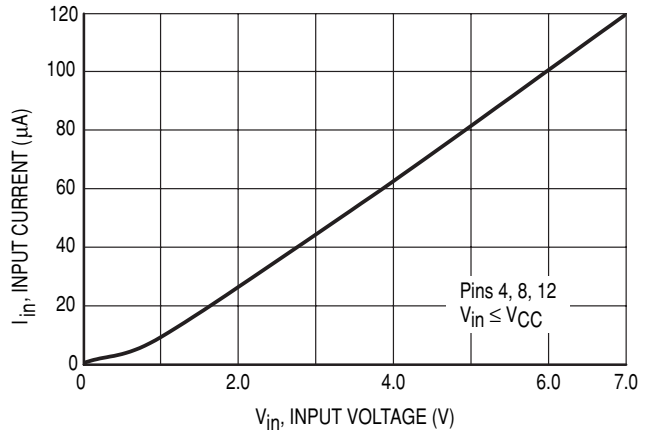

Figure 14. Logic Inputs' Current





## FUNCTIONAL DESCRIPTION

## Introduction

The ML33111 compander (COMpressor and exPANDER) is composed of two variable gain circuits which provide compression and expansion of a signal's dynamic range. The compressor will take a signal with a 60 dB dynamic range (1.0 mV to 1.0 V<sub>rms</sub>), and reduce that to a 30 dB dynamic range (10 mV to 316 mV) by attenuating strong signals, while amplifying low level signals. The expander does the opposite in that the 30 dB signal range is increased to a dynamic range of 60 dB by amplifying strong signals and attenuating low level signals. The 0 dB level is internally set at 100 mV<sub>rms</sub> — that is the signal level which is neither amplified nor attenuated. Both circuits contain the necessary precision full wave rectifier, variable gain cell, and temperature compensated references required for accurate and stable performance.

Both the compressor and expander can be muted independently by the use of Pins 4 and 12, respectively. A minimum of 55 dB of muting is guaranteed for the compressor, and 60 dB for the expander. A passthrough function (Pin 8) is provided which sets both sections to unity gain, regardless of input level.

Two uncommitted op amps are provided which can be used for peripheral functions. Each is internally biased at V<sub>b</sub> (≈ +1.5 V), and has a bandwidth of ≈300 kHz.

NOTE: All dB values mentioned in this data sheet, unless otherwise noted, are referenced to 100 mV<sub>rms</sub>.

Figure 15. Compressor

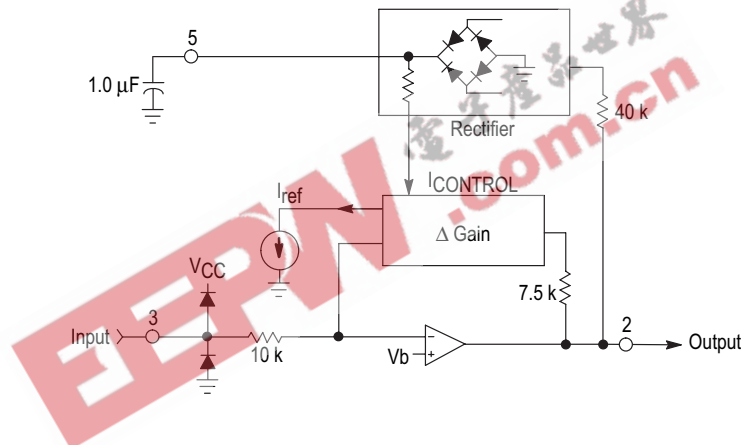

## Compressor

The compressor is a noninverting amplifier with a fixed input resistor and a variable gain cell in its feedback path as shown in Figure 15.

The amplifier output is sampled by the precision rectifier which, in turn, supplies a DC signal (ICONTROL), representative of the rectifier's AC signal, to the variable gain cell. The reference current (IREF) is an internally generated precision current. The effective impedance of the variable gain cell varies with the ratio of the two currents, and decreases as ICONTROL increases, thereby providing compression. The output is related to the input by the following equation (V<sub>in</sub> and V<sub>out</sub> are rms volts):

$$V_{out} = 0.3162 \times \sqrt{V_{in}} \quad (1)$$

In terms of dB levels, the relationship is:

$$V_o(\text{dB}) = 0.5 \times V_i(\text{dB}) \quad (2)$$

where 0 dB = 100 mV<sub>rms</sub> (See Figures 3 and 4).

The input and output are internally biased at V<sub>b</sub> (≈ +1.5 V), and must therefore be capacitor coupled to external circuitry. Pin 3 input impedance is nominally 10 kΩ (±20%), and the

maximum functional input signal is listed in the Recommended Operating Conditions table. Bias currents required by the op amp and the variable gain cell are internally supplied. Due to clamp diodes at the input (to V<sub>CC</sub> and ground), the input signal must be maintained between the supply rails. If the input signal goes more than 0.5 V above V<sub>CC</sub> or below ground, excessive currents will flow, and distortion will show up at the output and possibly in other parts of the circuit.

When AC signals are not present at the input, the variable gain cell will attempt to set a very high gain to comply with Equation 2. An internal clamp limits the maximum gain to ≈26 dB to prevent instabilities.

The output of the rectifier is filtered by the capacitor at Pin 5, which, in conjunction with an internal 20 k resistor, provides the time constant for the attack and decay times. The attack and decay times listed in the Electrical Characteristics were determined using the test procedure defined in EIA-553. Figure 9 indicates how the times vary with the capacitor value. If the attack and decay times are decreased using a smaller capacitor, performance at low frequencies will degrade.



Figure 16. Expander

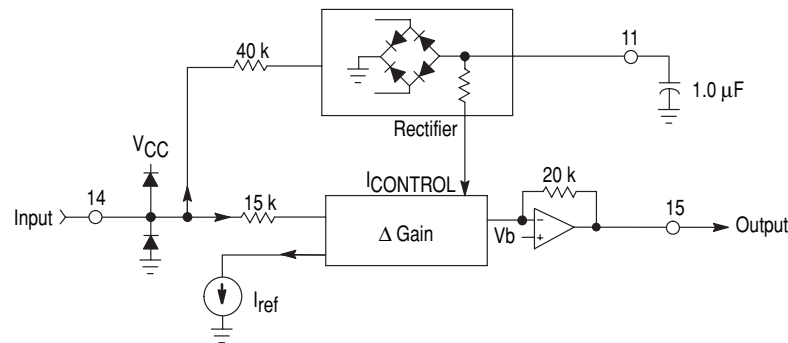

### Expander

The expander is a noninverting amplifier with a fixed feedback resistor and a variable gain cell in its input path as shown in Figure 16.

The input signal is sampled by the precision rectifier which, in turn, supplies a DC signal ( $I_{CONTROL}$ ), representative of the AC input signal, to the variable gain cell. The reference current ( $I_{REF}$ ) is an internally generated precision current. The effective impedance of the variable gain cell varies with the ratio of the two currents, and decreases as  $I_{CONTROL}$  increases, thereby providing expansion. The output is related to the input by the following equation ( $V_{in}$  and  $V_{out}$  are rms volts):

$$V_{out} = 10 \times (V_{in})^2 \quad (3)$$

In terms of dB levels, the relationship is:

$$V_o(\text{dB}) = 2.0 \times V_i(\text{dB}) \quad (4)$$

where 0 dB = 100 mVrms (See Figures 3 and 4).

The input and output are internally biased at  $V_b$  ( $\approx +1.5$  V), and must therefore be capacitor coupled to external circuitry. The input impedance at Pin 14 is nominally 10.9 k $\Omega$  ( $\pm 20\%$ ), and the maximum functional input signal is listed in the Recommended Operating Conditions table. Bias currents required by the op amp and the variable gain cell are internally supplied. Due to clamp diodes at the input (to  $V_{CC}$  and ground), the input signal must be maintained between the supply rails. If the input signal goes more than 0.5 V above  $V_{CC}$  or below ground, excessive currents will flow, and distortion will show up at the output, and possibly in other parts of the circuit.

The output of the rectifier is filtered by the capacitor at Pin 11, which, in conjunction with an internal 20 k resistor, provides the time constant for the attack and decay times. The attack and decay times listed in the Electrical Characteristics were determined using the test procedure defined in EIA-553. Figure 10 indicates how the times vary with the capacitor value. If the attack and decay times are decreased by using a smaller capacitor, performance at low frequencies will degrade.

### Op Amps

The two op amps (at Pins 6, 7, 9, and 10) are identical and can be used for peripheral functions, such as a microphone amplifier, buffer, filter, etc. They have an open loop gain of  $\approx 100$  dB, and a bandwidth of  $\approx 300$  kHz. The noninverting inputs are internally biased at  $V_b$  ( $\approx +1.5$  V). The inverting inputs (Pins 7, 9) require a bias current of  $\approx 8.0$  nA, which

flows into the pin. The outputs can typically supply a maximum of 3.7 mA load current (see Electrical Characteristics).

**NOTE:** If an op amp is unused, its output MUST be tied to its input (Pin 6 to 7 and/or 9 to 10). Leaving an input open can affect other portions of the IC.

### Logic Inputs

The three inputs (Pins 4, 8, 12) provide for muting and passthrough functions for the compressor and expander according to the following truth table:

CM (Pin 4)	EM (Pin 12)	PT (Pin 8)	Function
0	0	0	Normal Operation
1	X	X	Compressor Mute
X	1	X	Expander Mute
0	0	1	Passthrough

The logic section permits the compressor and expander to be muted independently. The Passthrough control affects both sections simultaneously, but only if the Mute inputs are at a logic level 0. If both the Passthrough and a Mute input are asserted, the Mute will override the Passthrough. The logic controls do not affect the two uncommitted op amps in any way.

Figure 17 depicts a typical logic input stage configuration, and Figure 14 indicates the typical input current. The inputs' threshold is  $\approx +1.3$  V, independent of  $V_{CC}$ . An open input is equivalent to a logic low, but good design practices dictate that inputs should never be left open. The inputs must be kept within the range of  $V_{CC}$  and GND. If an input is taken more than 0.5 V above  $V_{CC}$  or below GND excessive currents will flow, and the device's operation will be distorted.

Figure 17. Logic Input Stage

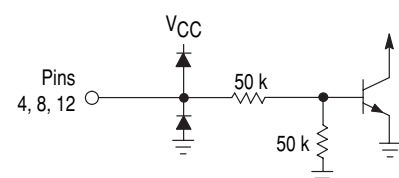

### Power Supply

The ML33111 requires a supply voltage between 3.0 V and 7.0 V, and a nominal current of  $\approx 1.6$  mA. The supply voltage should be well filtered and free of ripple. A minimum of 4.7  $\mu$ F in parallel with a 0.01  $\mu$ F capacitor is recommended for filtering and RF bypass.

V<sub>b</sub> is an internally generated reference set at  $\approx +1.5$  V, and is used internally as an AC ground. It is not available directly at any pins, but can be obtained as a buffered reference from either op amp by connecting the op amp as a follower.

## LEGACY APPLICATIONS INFORMATION

### Typical Application Circuit

Figure 18 indicates a typical implementation of the ML33111 compander. The following points apply:

- The values shown adjacent to some components are based on the expected use of the IC:
  - The input capacitors (Pins 3 and 14) provide a 3.0 dB rolloff of  $\approx 30$  Hz, a decade below the nominal voiceband.
  - The rectifier capacitors provide attack and decay times as indicated in the Electrical Tables.
- The values for the unlabeled components are application dependent:
  - The components around the op amps depend on their use.
  - The value of the capacitors at the compressor and expander outputs depend on the circuit to which they are connected.

- If either the compressor or expander is not used, its input **must** not be left open. It can be connected to ground either through a capacitor, or directly to ground.
- The two op amps can be used for any purpose which suits the application. The indicated use of the one op amp as a microphone amplifier is only an example.
- If an op amp is not used, its output and input must be connected together. Do not leave Pin 7 or Pin 9 open.
- The logic inputs (Pins 4, 8, 12) are TTL/CMOS compatible. The logic high voltage must not exceed the V<sub>CC</sub> voltage on the ML33111. Any unused input should be connected to ground and not left open.

Figure 18. Typical Application

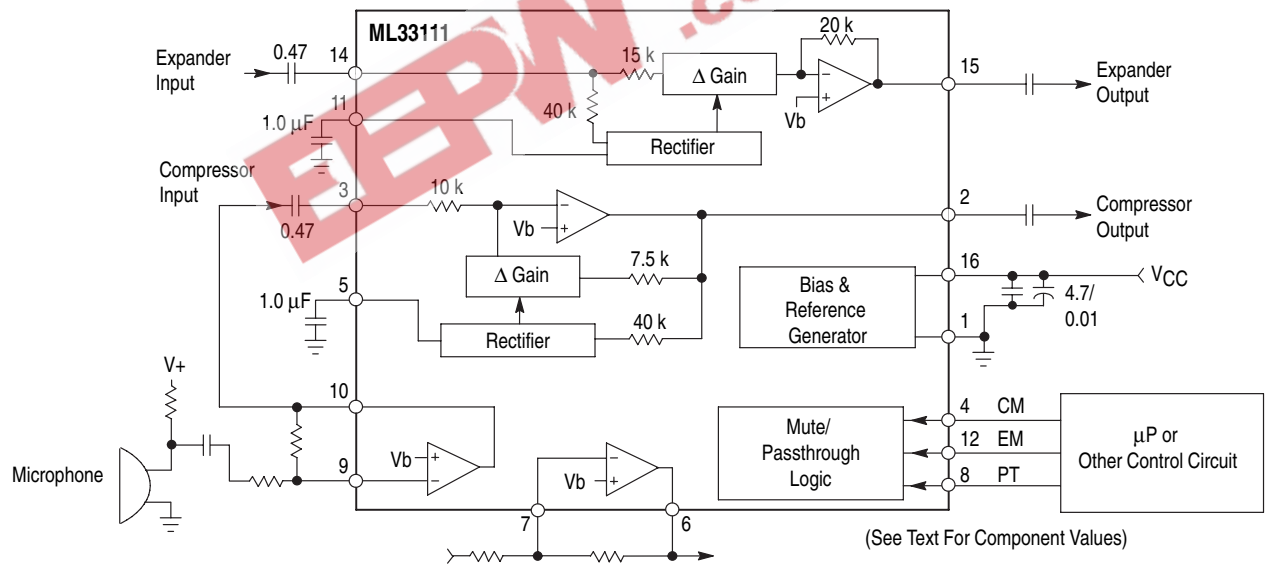

### Signal-To-Noise Improvement

Among the basic reasons for the original development of compander type circuits was to improve the signal-to-noise ratio of long distance communications circuits, and of voice circuits which are transmitted over RF links (CBs, walkie-talkies, cordless phones, etc.). Since much of the interfering noise heard at the receiving end of a transmission is due to noise picked up, for example, in the airway portion of the RF link, the compressor was developed to increase the low-level signals at the transmitting end. Then any noise picked up in the RF link would be a smaller percentage of the transmitted signal

level. At the receiving end, the signal is then expanded back to its original level, retaining the same high signal-to-noise ratio. While the above explanation indicates it is not necessary to attenuate strong signals (at the transmitting end), a benefit of doing this is the reduced dynamic range which must be handled by the system transmitter and receiver. The ML33111 was designed for a two-to-one compression and expansion, i.e. a 60 dB dynamic signal is compressed to a 30 dB dynamic range, transmitted to the receiving end, and then expanded back to a 60 dB dynamic range.

### Legacy Applications Information

The ML33111 compander is not limited to RF or long distance telephony applications. It can be used in any system requiring either an improved signal-to-noise ratio, or a reduced dynamic range. Such applications include telephones, speakerphones, tape recorders, wireless microphones, digital recording, and many others.

### Power Supplies, Grounding

The PC board layout, and the quality of the power supplies and the ground system **at the IC** are very important in order to obtain proper operation. Noise, from any source, coming into the device on  $V_{CC}$  or ground, can cause a distorted output, or incorrect gain levels.

$V_{CC}$  must be decoupled to the appropriate ground **at the IC** (within 1" max.) with a 4.7  $\mu\text{F}$  capacitor and a 0.01  $\mu\text{F}$  ceramic. A tantalum capacitor is recommended for the larger value if very high frequency noise is present, since electrolytic capacitors simply have too much inductance at those frequencies. The quality of the power supply voltage should be checked at the IC with a high frequency scope. Noise spikes (always present if digital circuits are near this IC) can easily exceed 400 mV, and if they get into the IC, the output can have noise or distortion. Noise can be reduced by inserting resistors and/or inductors between the supply and the IC.

If switching power supplies are used, there will be spikes of 0.5 V or greater at frequencies of 50 kHz – 1.0 MHz. These spikes are generally more difficult to reduce because of their greater energy content. In extreme cases, a 3-terminal regulator (e.g., MC78L05ACP), with appropriate high fre-

quency filtering, should be used and dedicated to the analog portion of the circuit. The ripple content of the supply should not allow its magnitude to exceed the values in the Recommended Operating Conditions table.

The PC board tracks supplying  $V_{CC}$  and ground to the ML33111 should preferably not be at the tail end of the bus distribution, after passing through a maze of digital circuitry. The analog circuitry containing the ML33111 should be close to the power supply, or the connector where the supply voltages enter the board. If  $V_{CC}$  is supplying considerable current to other parts of the board, then it is preferable to have dedicated lines directly to the ML33111 and associated circuitry.

### PC Board Layout

Although this device is intended for use in the audio frequency range, the various amplifiers have a bandwidth of  $\approx 300$  kHz, and can therefore oscillate at frequencies outside the voiceband should there be excessive stray capacitance or other unintended feedback loops. A solid ground plane is strongly recommended to minimize coupling of any digital noise into the analog section. Use of wire wrapped boards should definitely be avoided.

Since many applications of the ML33111 compander involve voice transmission over RF links, care must be taken in the design of the product to keep RF signals out of the ML33111 and associated circuitry. This involves proper layout of the PC boards and the physical arrangement of the boards, shielding, proper RF ground, etc.

## DEFINITIONS

**Attack Time** — The settling time for a circuit after its input signal has been increased.

**Attenuation** — A decrease in magnitude of a communication signal, usually expressed in dB.

**Bandwidth** — The range of information carrying frequencies of a communication system.

**Channel Separation** — The ability of one circuit to reject outputting signals which are being processed by another circuit. Also referred to as crosstalk rejection, it is usually expressed in dB.

**Compander** — A contraction of the words compressor and expander. A compander is composed of two circuits, one of each kind.

**Compressor** — A circuit which compresses, or reduces, the dynamic range of a signal by attenuating strong signals and amplifying low level signals.

**dB** — A power or voltage measurement unit, referred to another power or voltage. It is generally computed as:

$$10 \times \log (P1/P2) \text{ for power signals, and} \\ 20 \times \log (V1/V2) \text{ for voltage signals.}$$

**dBm** — An indication of signal power. 1.0 mW across 600  $\Omega$ , or 0.775 Vrms, is typically defined as 0 dBm for telecom applications. Any voltage level is converted to dBm by:

$$\text{dBm} = 20 \times \log (V_{\text{rms}}/0.775), \text{ or} \\ \text{dBm} = [20 \times \log (V_{\text{rms}})] + 2.22.$$

**dBm** — Indicates a dBm measurement relative to 1.0 pW power level into 600  $\Omega$ . Generally used for noise measurements, 0 dBm = -90 dBm.

**dBmC** — Indicates a dBm measurement using a C-message weighting filter.

**Decay Time** — The settling time for a circuit after its input signal has been decreased.

**Expander** — A circuit which expands, or increases the dynamic range of a signal by amplifying strong signals and attenuating low level signals.

**Gain** — The change in signal amplitude (increase or decrease) after passing through an amplifier, or other circuit stage. Usually expressed in dB, an increase is a positive number, and a decrease is a negative number.

**Mute** — Reducing the level of an audio signal, generally so that it is inaudible. Partial muting is used in some applications.

**Passthrough** — Bypassing the compression and/or expansion function by setting the gain to a fixed value (usually unity). This is usually employed when data, rather than voice, is to be transmitted without attenuation.

**Power Supply Rejection Ratio** — The ability of a circuit to reject outputting noise, or ripple, which is present on the power supply lines. PSRR is usually expressed in dB.

**Signal to Noise Ratio** — The ratio of the desired signal to unwanted signals (noise) within a defined frequency range. The larger the number, the better.

**Voiceband** — That portion of the audio frequency range used for transmission in the telephone system. Typically it is 300-3400 Hz.

**Zero dB Point** — The signal level which has its amplitude unchanged by a compressor or expander.

OUTLINE DIMENSIONS

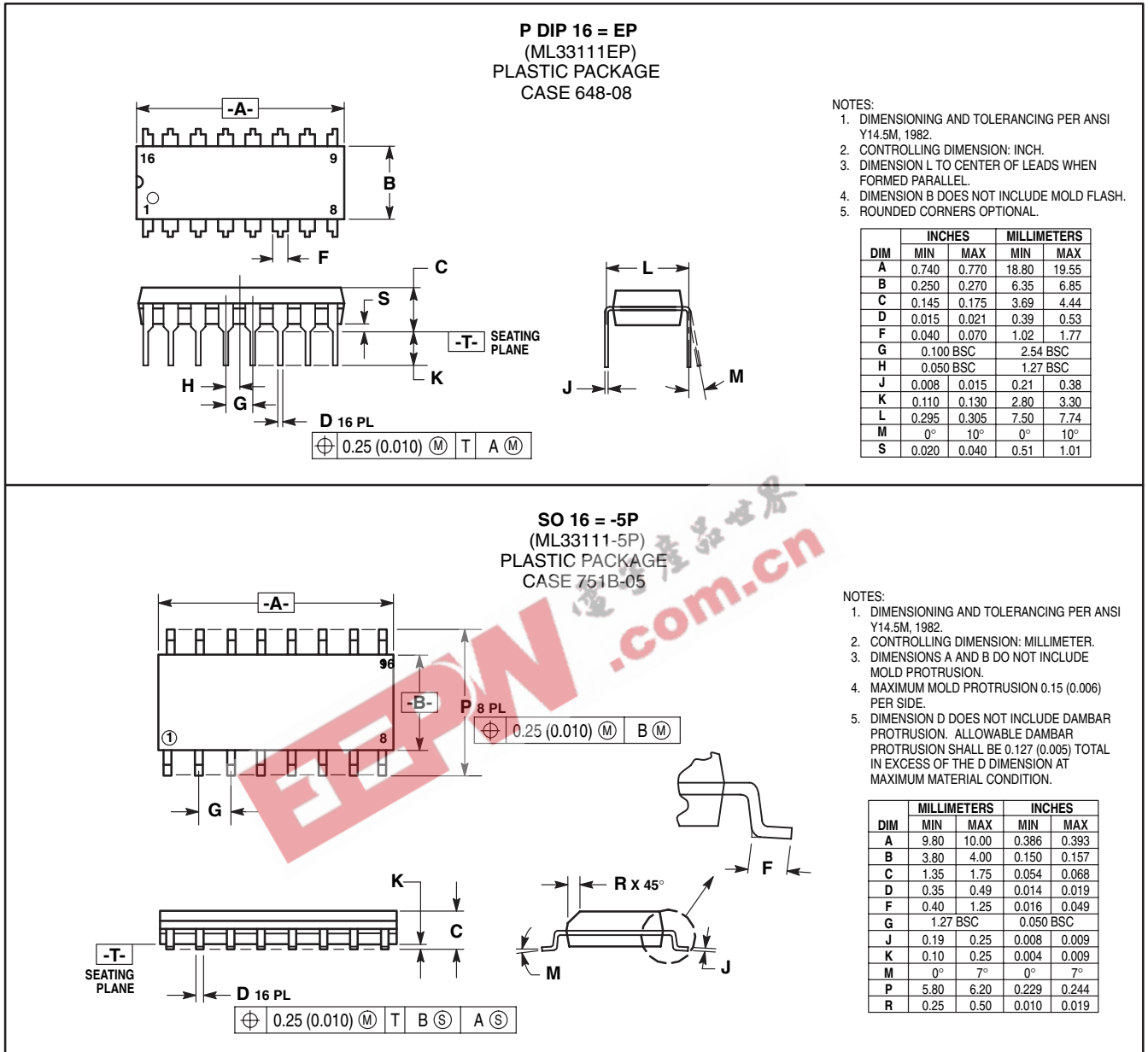

Lansdale Semiconductor reserves the right to make changes without further notice to any products herein to improve reliability, function or design. Lansdale does not assume any liability arising out of the application or use of any product or circuit described herein; neither does it convey any license under its patent rights nor the rights of others. "Typical" parameters which may be provided in Lansdale data sheets and/or specifications can vary in different applications, and actual performance may vary over time. All operating parameters, including "Typicals" must be validated for each customer application by the customer's technical experts. Lansdale Semiconductor is a registered trademark of Lansdale Semiconductor, Inc.