

MC34025, MC33025

High Speed Double-Ended PWM Controller

The MC34025 series are high speed, fixed frequency, double-ended pulse width modulator controllers optimized for high frequency operation. They are specifically designed for Off-Line and DC-to-DC converter applications offering the designer a cost effective solution with minimal external components. These integrated circuits feature an oscillator, a temperature compensated reference, a wide bandwidth error amplifier, a high speed current sensing comparator, steering flip-flop, and dual high current totem pole outputs ideally suited for driving power MOSFETs.

Also included are protective features consisting of input and reference undervoltage lockouts each with hysteresis, cycle-by-cycle current limiting, and a latch for single pulse metering.

The flexibility of this series allows it to be easily configured for either current mode or voltage mode control.

Features

- 50 ns Propagation Delay to Outputs
- Dual High Current Totem Pole Outputs
- Wide Bandwidth Error Amplifier
- Fully-Latched Logic with Double Pulse Suppression
- Latching PWM for Cycle-By-Cycle Current Limiting
- Soft-Start Control with Latched Overcurrent Reset
- Input Undervoltage Lockout with Hysteresis
- Low Startup Current (500 μ A Typ)
- Internally Trimmed Reference with Undervoltage Lockout
- 45% Maximum Duty Cycle (Externally Adjustable)
- Precision Trimmed Oscillator
- Voltage or Current Mode Operation to 1.0 MHz
- Functionally Similar to the UC3825
- Pb-Free Packages are Available*

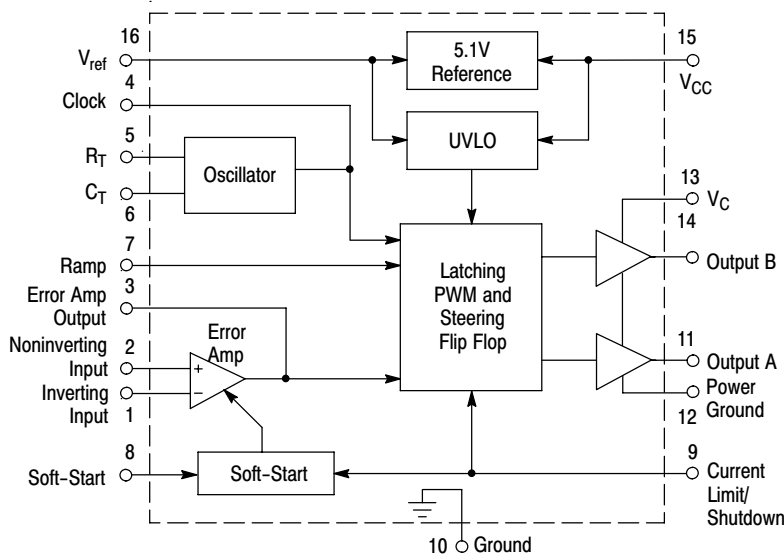

This device contains 227 active transistors.

Figure 1. Simplified Application



ON Semiconductor®

<http://onsemi.com>

MARKING DIAGRAMS

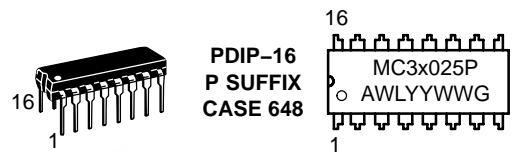

PDIP-16
P SUFFIX
CASE 648



SO-16WB
DW SUFFIX
CASE 751G

- x = 3 or 4
- A = Assembly Location
- WL = Wafer Lot
- YY = Year
- WW = Work Week
- G = Pb-Free Package

PIN CONNECTIONS

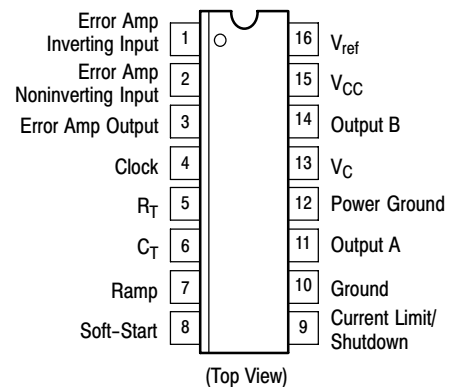

ORDERING INFORMATION

See detailed ordering and shipping information in the package dimensions section on page 18 of this data sheet.

*For additional information on our Pb-Free strategy and soldering details, please download the ON Semiconductor Soldering and Mounting Techniques Reference Manual, SOLDERRM/D.

MC34025, MC33025

MAXIMUM RATINGS

Rating	Symbol	Value	Unit
Power Supply Voltage	V_{CC}	30	V
Output Driver Supply Voltage	V_C	25	V
Output Current, Source or Sink (Note 1) DC Pulsed (0.5 μ s)	I_O	0.5 2.0	A
Current Sense, Soft-Start, Ramp, and Error Amp Inputs	V_{in}	-0.3 to +7.0	V
Error Amp Output and Soft-Start Sink Current	I_O	10	mA
Clock and R_T Output Current	I_{CO}	5.0	mA
Power Dissipation and Thermal Characteristics SO-16 Package (Case 751G) Maximum Power Dissipation @ $T_A = +25^\circ\text{C}$ Thermal Resistance, Junction-to-Air DIP Package (Case 648) Maximum Power Dissipation @ $T_A = +25^\circ\text{C}$ Thermal Resistance, Junction-to-Air	P_D $R_{\theta JA}$ P_D $R_{\theta JA}$	862 145 1.25 100	mW $^\circ\text{C/W}$ W $^\circ\text{C/W}$
Operating Junction Temperature	T_J	+150	$^\circ\text{C}$
Operating Ambient Temperature (Note 2) MC34025 MC33025	T_A	0 to +70 -40 to +105	$^\circ\text{C}$
Storage Temperature Range	T_{stg}	-55 to +150	$^\circ\text{C}$

Maximum ratings are those values beyond which device damage can occur. Maximum ratings applied to the device are individual stress limit values (not normal operating conditions) and are not valid simultaneously. If these limits are exceeded, device functional operation is not implied, damage may occur and reliability may be affected.

ELECTRICAL CHARACTERISTICS ($V_{CC} = 15\text{ V}$, $R_T = 3.65\text{ k}\Omega$, $C_T = 1.0\text{ nF}$, for typical values $T_A = +25^\circ\text{C}$, for min/max values T_A is the operating ambient temperature range that applies [Note 2], unless otherwise noted.)

Characteristic	Symbol	Min	Typ	Max	Unit
----------------	--------	-----	-----	-----	------

REFERENCE SECTION

Reference Output Voltage ($I_O = 1.0\text{ mA}$, $T_J = +25^\circ\text{C}$)	V_{ref}	5.05	5.1	5.15	V
Line Regulation ($V_{CC} = 10\text{ V to }30\text{ V}$)	Reg_{line}	-	2.0	15	mV
Load Regulation ($I_O = 1.0\text{ mA to }10\text{ mA}$)	Reg_{load}	-	2.0	15	mV
Temperature Stability	T_S	-	0.2	-	mV/ $^\circ\text{C}$
Total Output Variation over Line, Load, and Temperature	V_{ref}	4.95	-	5.25	V
Output Noise Voltage ($f = 10\text{ Hz to }10\text{ kHz}$, $T_J = +25^\circ\text{C}$)	V_n	-	50	-	μV
Long Term Stability ($T_A = +125^\circ\text{C}$ for 1000 Hours)	S	-	5.0	-	mV
Output Short Circuit Current	I_{SC}	-30	-65	-100	mA

OSCILLATOR SECTION

Frequency $T_J = +25^\circ\text{C}$ Line ($V_{CC} = 10\text{ V to }30\text{ V}$) and Temperature ($T_A = T_{low}$ to T_{high})	f_{osc}	380 370	400 400	420 430	kHz
Frequency Change with Voltage ($V_{CC} = 10\text{ V to }30\text{ V}$)	$\Delta f_{osc}/\Delta V$	-	0.2	1.0	%
Frequency Change with Temperature ($T_A = T_{low}$ to T_{high})	$\Delta f_{osc}/\Delta T$	-	2.0	-	%
Sawtooth Peak Voltage	V_P	2.6	2.8	3.0	V
Sawtooth Valley Voltage	V_V	0.7	1.0	1.25	V
Clock Output Voltage High State Low State	V_{OH} V_{OL}	3.9 -	4.5 2.3	- 2.9	V

- Maximum package power dissipation limits must be observed.
- Low duty cycle pulse techniques are used during test to maintain junction temperature as close to ambient as possible.
 $T_{low} = 0^\circ\text{C}$ for MC34025 $T_{high} = +70^\circ\text{C}$ for MC34025
 $= -40^\circ\text{C}$ for MC33025 $= +105^\circ\text{C}$ for MC33025

MC34025, MC33025

ELECTRICAL CHARACTERISTICS ($V_{CC} = 15\text{ V}$, $R_T = 3.65\text{ k}\Omega$, $C_T = 1.0\text{ nF}$, for typical values $T_A = +25^\circ\text{C}$, for min/max values T_A is the operating ambient temperature range that applies [Note 4], unless otherwise noted.)

Characteristic	Symbol	Min	Typ	Max	Unit
ERROR AMPLIFIER SECTION					
Input Offset Voltage	V_{IO}	–	–	15	mV
Input Bias Current	I_{IB}	–	0.6	3.0	μA
Input Offset Current	I_{IO}	–	0.1	1.0	μA
Open-Loop Voltage Gain ($V_O = 1.0\text{ V to }4.0\text{ V}$)	A_{VOL}	60	95	–	dB
Gain Bandwidth Product ($T_J = +25^\circ\text{C}$)	GBW	4.0	8.3	–	MHz
Common Mode Rejection Ratio ($V_{CM} = 1.5\text{ V to }5.5\text{ V}$)	CMRR	75	95	–	dB
Power Supply Rejection Ratio ($V_{CC} = 10\text{ V to }30\text{ V}$)	PSRR	85	110	–	dB
Output Current, Source ($V_O = 4.0\text{ V}$) Sink ($V_O = 1.0\text{ V}$)	I_{Source} I_{Sink}	0.5 1.0	3.0 3.6	– –	mA
Output Voltage Swing, High State ($I_O = -0.5\text{ mA}$) Low State ($I_O = 1.0\text{ mA}$)	V_{OH} V_{OL}	4.5 0	4.75 0.4	5.0 1.0	V
Slew Rate	SR	6.0	12	–	V/ μs

PWM COMPARATOR SECTION

Ramp Input Bias Current	I_{IB}	–	–0.5	–5.0	μA
Duty Cycle of Each Output, Maximum Minimum	$DC_{(max)}$ $DC_{(min)}$	40 –	45 –	– 0	%
Zero Duty Cycle Threshold Voltage Pin 3(4) (Pin 7(9) = 0 V)	V_{th}	1.1	1.25	1.4	V
Propagation Delay (Ramp Input to Output, $T_J = +25^\circ\text{C}$)	$t_{PLH(in/out)}$	–	60	100	ns

SOFT-START SECTION

Charge Current ($V_{Soft-Start} = 0.5\text{ V}$)	I_{chg}	3.0	9.0	20	μA
Discharge Current ($V_{Soft-Start} = 1.5\text{ V}$)	I_{dischg}	1.0	4.0	–	mA

CURRENT SENSE SECTION

Input Bias Current (Pin 9(12) = 0 V to 4.0 V)	I_{IB}	–	–	15	μA
Current Limit Comparator Threshold	V_{th}	0.9	1.0	1.10	V
Shutdown Comparator Threshold	V_{th}	1.25	1.40	1.55	V
Propagation Delay (Current Limit/Shutdown to Output, $T_J = +25^\circ\text{C}$)	$t_{PLH(in/out)}$	–	50	80	ns

OUTPUT SECTION

Output Voltage Low State $(I_{Sink} = 20\text{ mA})$ $(I_{Sink} = 200\text{ mA})$ High State $(I_{Source} = 20\text{ mA})$ $(I_{Source} = 200\text{ mA})$	V_{OL} V_{OH}	– – 13 12	0.25 1.2 13.5 13	0.4 2.2 – –	V
Output Voltage with UVLO Activated ($V_{CC} = 6.0\text{ V}$, $I_{Sink} = 0.5\text{ mA}$)	$V_{OL(UVLO)}$	–	0.25	1.0	V
Output Leakage Current ($V_C = 20\text{ V}$)	I_L	–	100	500	μA
Output Voltage Rise Time ($C_L = 1.0\text{ nF}$, $T_J = +25^\circ\text{C}$)	t_r	–	30	60	ns
Output Voltage Fall Time ($C_L = 1.0\text{ nF}$, $T_J = +25^\circ\text{C}$)	t_f	–	30	60	ns

UNDERVOLTAGE LOCKOUT SECTION

Startup Threshold (V_{CC} Increasing)	$V_{th(on)}$	8.8	9.2	9.6	V
UVLO Hysteresis Voltage (V_{CC} Decreasing After Turn-On)	V_H	0.4	0.8	1.2	V

TOTAL DEVICE

Power Supply Current Startup ($V_{CC} = 8.0\text{ V}$) Operating	I_{CC}	– –	0.5 25	1.2 35	mA
--	----------	--------	-----------	-----------	----

- Maximum package power dissipation limits must be observed.
- Low duty cycle pulse techniques are used during test to maintain junction temperature as close to ambient as possible.
 $T_{low} = 0^\circ\text{C}$ for MC34025 $T_{high} = +70^\circ\text{C}$ for MC34025
 $= -40^\circ\text{C}$ for MC33025 $= +105^\circ\text{C}$ for MC33025

MC34025, MC33025

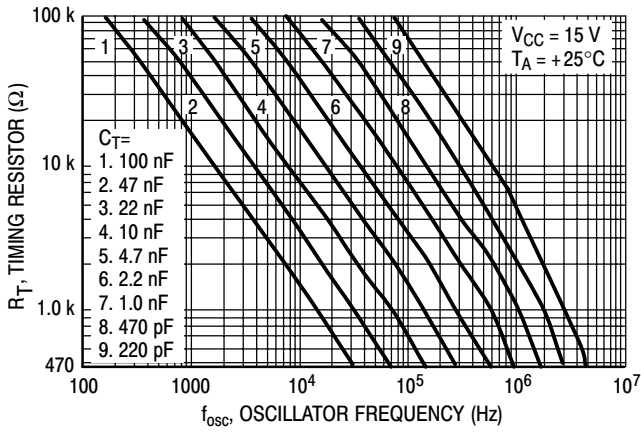

Figure 2. Timing Resistor versus Oscillator Frequency

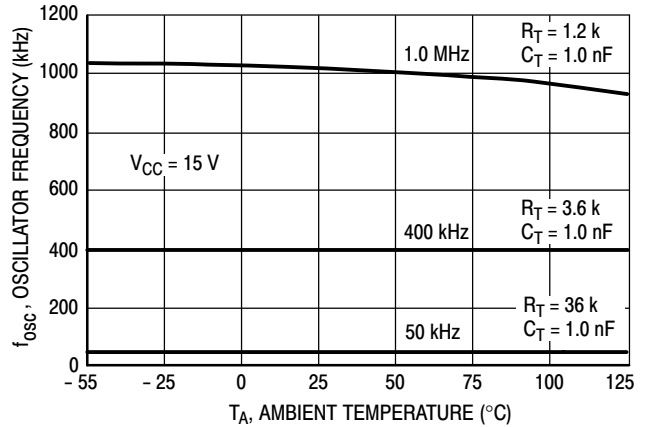

Figure 3. Oscillator Frequency versus Temperature

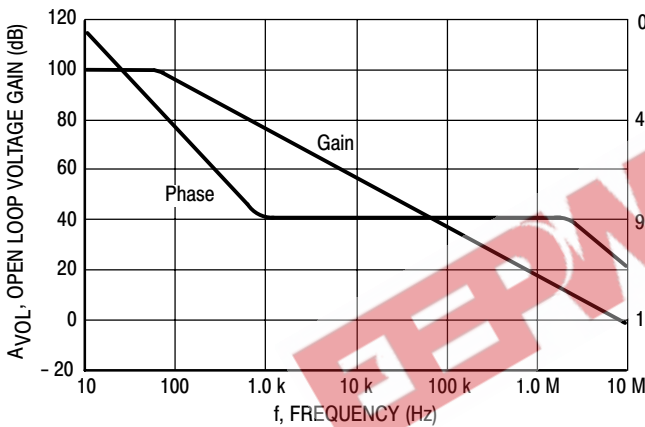

Figure 4. Error Amp Open Loop Gain and Phase versus Frequency

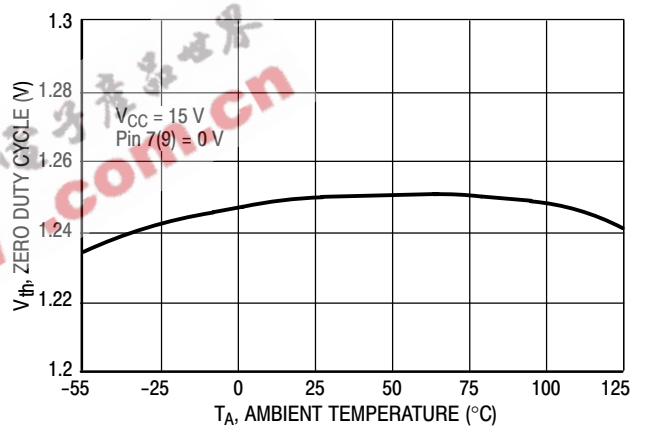

Figure 5. PWM Comparator Zero Duty Cycle Threshold Voltage versus Temperature

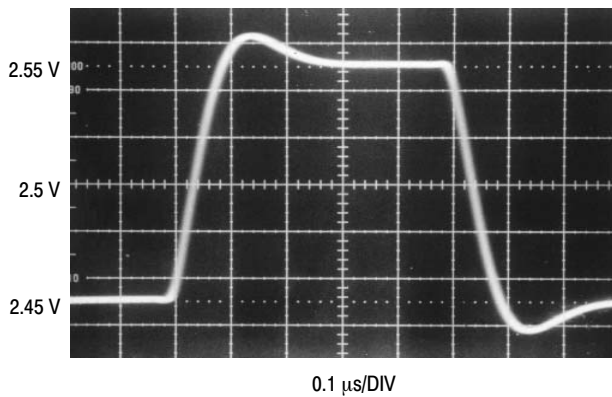

Figure 6. Error Amp Small Signal Transient Response

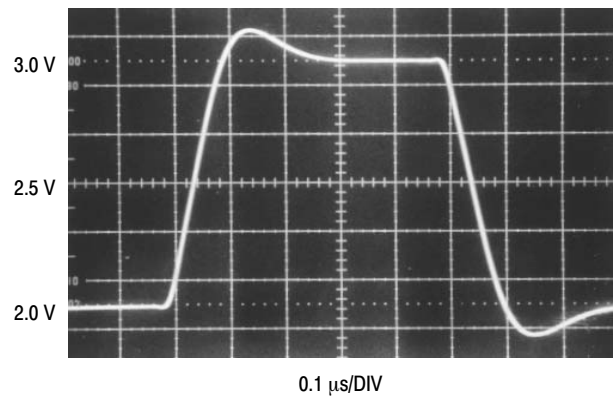

Figure 7. Error Amp Large Signal Transient Response

MC34025, MC33025

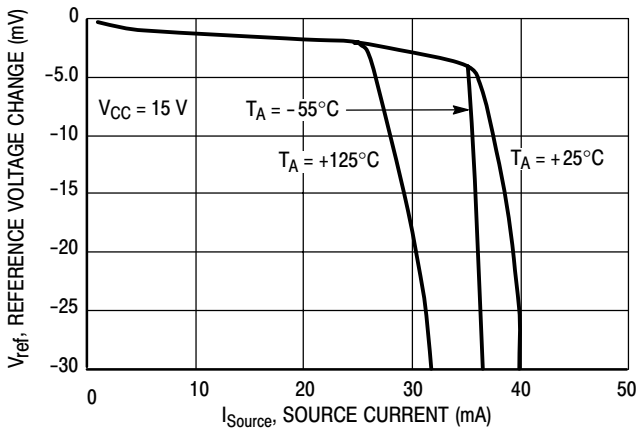

Figure 8. Reference Voltage Change versus Source Current

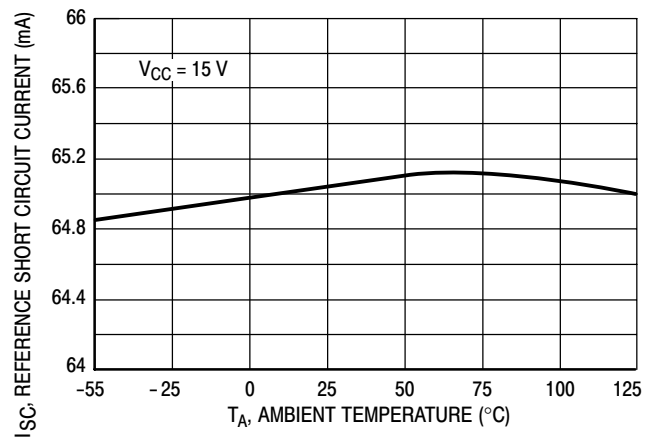

Figure 9. Reference Short Circuit Current versus Temperature

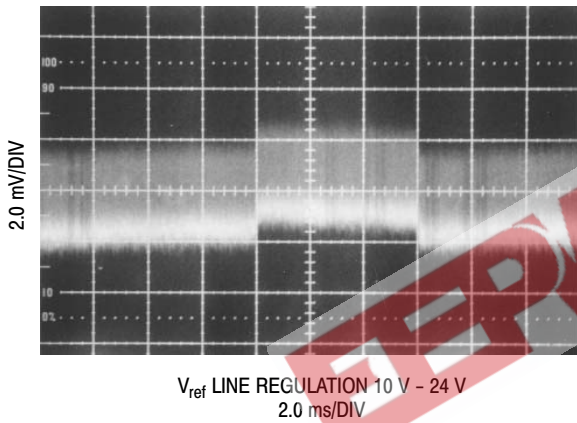

Figure 10. Reference Line Regulation

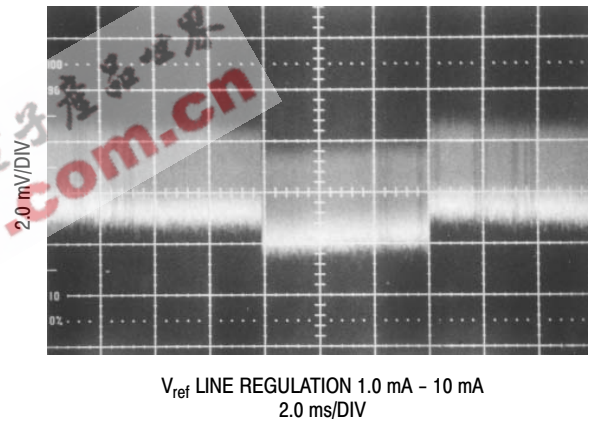

Figure 11. Reference Load Regulation

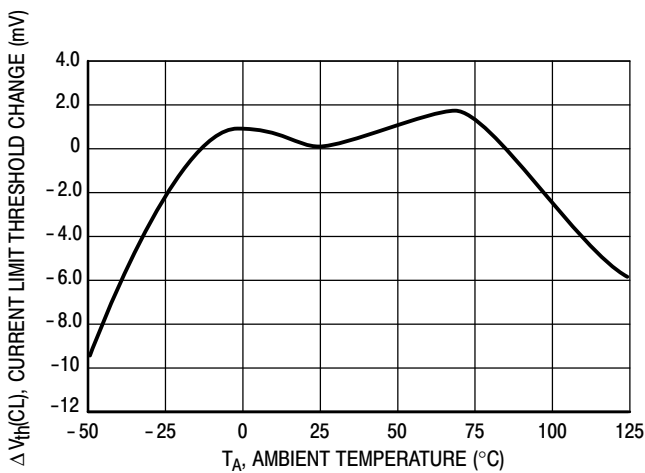

Figure 12. Current Limit Comparator Threshold Change versus Temperature

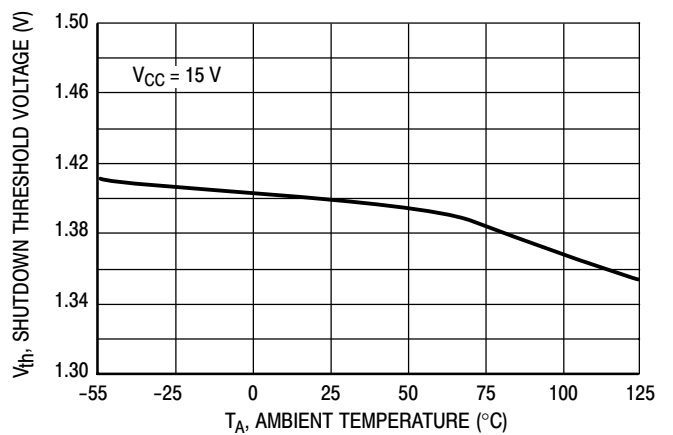

Figure 13. Shutdown Comparator Threshold Voltage versus Temperature

MC34025, MC33025

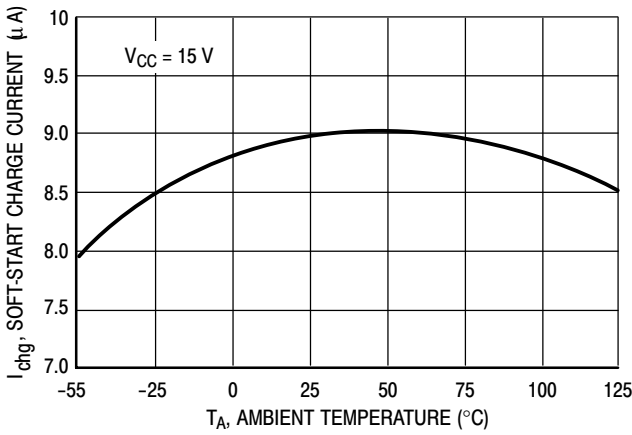

Figure 14. Soft-Start Charge Current versus Temperature

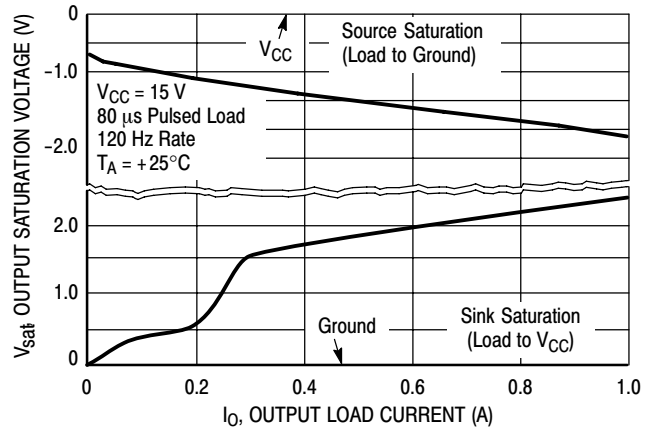
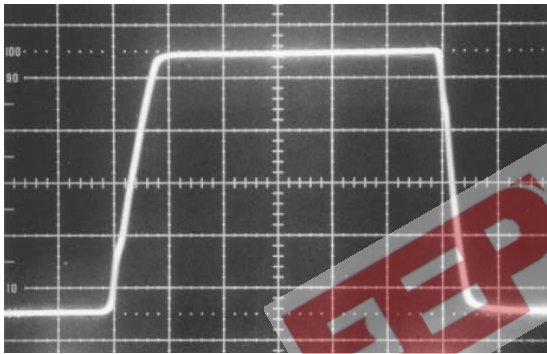
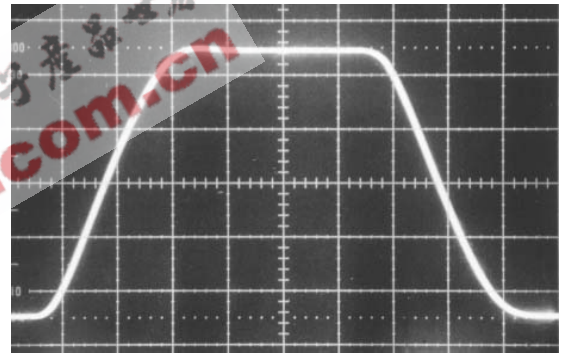

Figure 15. Output Saturation Voltage versus Load Current



OUTPUT RISE & FALL TIME 1.0 nF LOAD
50 ns/DIV

Figure 16. Drive Output Rise and Fall Time



OUTPUT RISE & FALL TIME 10.0 nF LOAD
50 ns/DIV

Figure 17. Drive Output Rise and Fall Time

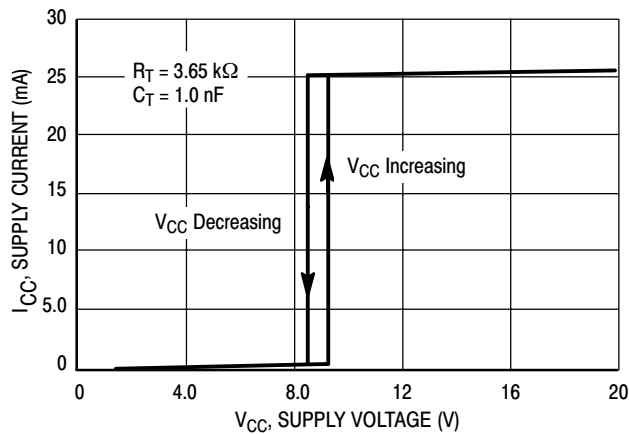

Figure 18. Supply Voltage versus Supply Current

MC34025, MC33025

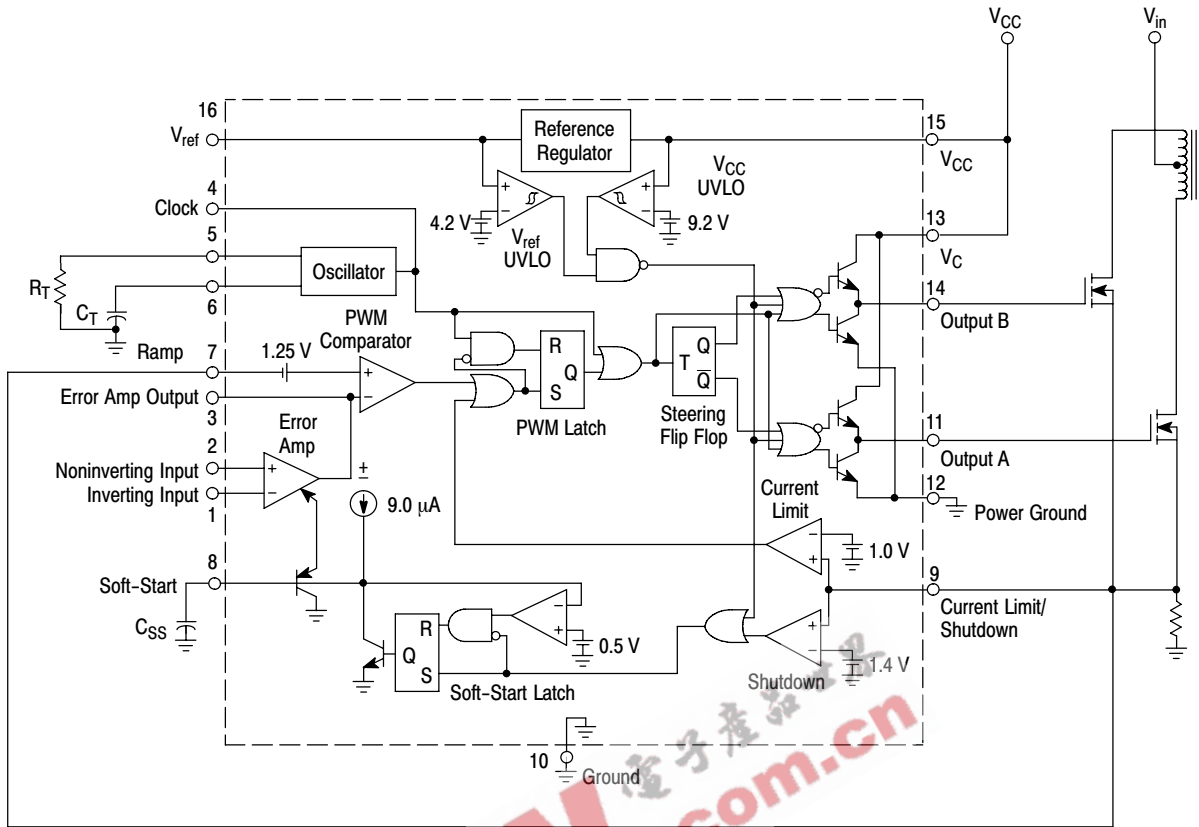

Figure 19. Representative Block Diagram

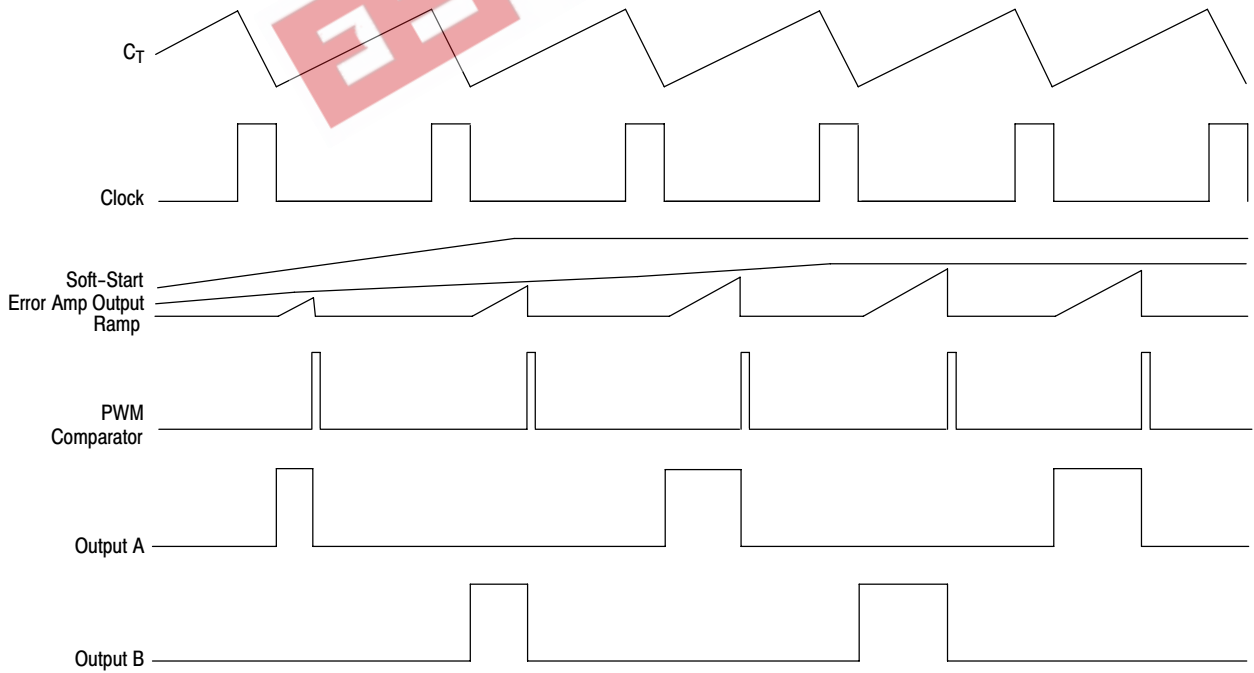

Figure 20. Current Limit Operating Waveforms

MC34025, MC33025

OPERATING DESCRIPTION

The MC33025 and MC34025 series are high speed, fixed frequency, double-ended pulse width modulator controllers optimized for high frequency operation. They are specifically designed for Off-Line and DC-to-DC converter applications offering the designer a cost effective solution with minimal external components. A representative block diagram is shown in Figure 19.

Oscillator

The oscillator frequency is programmed by the values selected for the timing components R_T and C_T . The R_T pin is set to a temperature compensated 3.0 V. By selecting the value of R_T , the charge current is set through a current mirror for the timing capacitor C_T . This charge current runs continuously through C_T . The discharge current ratio is to be 10 times the charge current, which yields the maximum duty cycle of 90%. C_T is charged to 2.8 V and discharged to 1.0 V. During the discharge of C_T , the oscillator generates an internal blanking pulse that resets the PWM Latch, inhibits the outputs, and toggles the steering flip-flop. The threshold voltages on the oscillator comparator is trimmed to guarantee an oscillator accuracy of 5.0% at 25°C.

Additional dead time can be added by externally increasing the charge current to C_T as shown in Figure 24. This changes the charge to discharge ratio of C_T which is set internally to $I_{\text{charge}}/10 I_{\text{charge}}$. The new charge to discharge ratio will be:

$$\% \text{ Deadtime} = \frac{I_{\text{additional}} + I_{\text{charge}}}{10 (I_{\text{charge}})}$$

A bidirectional clock pin is provided for synchronization or for master/slave operation. As a master, the clock pin provides a positive output pulse during the discharge of C_T . As a slave, the clock pin is an input that resets the PWM latch and blanks the drive output, but does not discharge C_T . Therefore, the oscillator is not synchronized by driving the clock pin alone. Figures 30 and 31 provide suggested synchronization.

Error Amplifier

A fully compensated Error Amplifier is provided. It features a typical DC voltage gain of 95 dB and a gain bandwidth product of 8.3 MHz with 75 degrees of phase margin (Figure 4). Typical application circuits will have the noninverting input tied to the reference. The inverting input will typically be connected to a feedback voltage generated from the output of the switching power supply. Both inputs have a Common Mode Voltage (V_{CM}) input range of 1.5 V to 5.5 V. The Error Amplifier Output is provided for external loop compensation.

Soft-Start Latch

Soft-Start is accomplished in conjunction with an external capacitor. The soft start capacitor is charged by an internal 9.0 μA current source. This capacitor clamps the output of the error amplifier to less than its normal output voltage, thus limiting the duty cycle.

The time it takes for a capacitor to reach full charge is given by:

$$t \approx (4.5 \cdot 10^5) C_{\text{Soft-Start}}$$

A Soft-Start latch is incorporated to prevent erratic operation of this circuitry. Two conditions can cause the Soft-Start circuit to latch so that the Soft-Start capacitor stays discharged. The first condition is activation of an undervoltage lockout of either V_{CC} or V_{ref} . The second condition is when current sense input exceeds 1.4 V. Since this latch is "set dominant", it cannot be reset until either of these signals is removed, and the voltage at $C_{\text{Soft-Start}}$ is less than 0.5 V.

PWM Comparator and Latch

A PWM circuit typically compares an error voltage with a ramp signal. The outcome of this comparison determines the state of the output. In voltage mode operation the ramp signal is the voltage ramp of the timing capacitor. In current mode operation the ramp signal is the voltage ramp induced in a current sensing element. The ramp input of the PWM comparator is pinned out so that the user can decide which mode of operation best suits the application requirements. The ramp input has a 1.25 V offset such that whenever the voltage at this pin exceeds the Error Amplifier Output voltage minus 1.25 V, the PWM comparator will cause the PWM latch to set, disabling the outputs. Once the PWM latch is set, only a blanking pulse by the oscillator can reset it, thus initiating the next cycle.

A toggle flip flop connected to the output of the PWM latch controls which output is active. The flip flop is pulsed by an OR gate that gets its inputs from the oscillator clock and the output of the PWM latch. A pulse from either one will cause the flip flop to enable the other output.

Current Limiting and Shutdown

A pin is provided to perform current limiting and shutdown operations. Two comparators are connected to the input of this pin. When the voltage at this pin exceeds 1.0 V, one of the comparators is activated. The output of this comparator sets the PWM latch, which disables the output. In this way cycle-by-cycle current limiting is accomplished. If a current limit resistor is used in series with the power devices, the value of the resistor is found by:

$$R_{\text{Sense}} = \frac{1.0 \text{ V}}{I_{\text{pk}} (\text{switch})}$$

MC34025, MC33025

If the voltage at this pin exceeds 1.4 V, the second comparator is activated. This comparator sets a latch which, in turn, causes the Soft-Start capacitor to be discharged. In this way a “hiccup” mode of recovery is possible in the case of output short circuits. If a current limit resistor is used in series with the output devices, the peak current at which the controller will enter a “hiccup” mode is given by:

$$I_{\text{shutdown}} = \frac{1.4 \text{ V}}{R_{\text{Sense}}}$$

Undervoltage Lockout

There are two undervoltage lockout circuits within the IC. The first senses V_{CC} and the second V_{ref} . During power-up, V_{CC} must exceed 9.2 V and V_{ref} must exceed 4.2 V before the outputs can be enabled and the Soft-Start latch released. If V_{CC} falls below 8.4 V or V_{ref} falls below 3.6 V, the outputs are disabled and the Soft-Start latch is activated. When the UVLO is active, the part is in a low current standby mode allowing the IC to have an off-line bootstrap startup circuit. Typical startup current is 500 μA .

Output

The MC34025 has two high current totem pole outputs specifically designed for direct drive of power MOSFETs. They are capable of up to ± 2.0 A peak drive current with a typical rise and fall time of 30 ns driving a 1.0 nF load.

Separate pins for V_C and Power Ground are provided. With proper implementation, a significant reduction of switching transient noise imposed on the control circuitry is possible. The separate V_C supply input also allows the designer added flexibility in tailoring the drive voltage independent of V_{CC} .

Reference

A 5.1 V bandgap reference is pinned out and is trimmed to an initial accuracy of $\pm 1.0\%$ at 25°C. This reference has short circuit protection and can source in excess of 10 mA for powering additional control system circuitry.

Design Considerations

Do not attempt to construct the converter on wire-wrap or plug-in prototype boards. With high frequency, high power, switching power supplies it is imperative to have separate current loops for the signal paths and for the power paths. The printed circuit layout should contain a ground plane with low current signal and high current switch and output grounds returning on separate

paths back to the input filter capacitor. All bypass capacitors and snubbers should be connected as close as possible to the specific part in question. The PC board lead lengths must be less than 0.5 inches for effective bypassing or snubbing.

Instabilities

In current mode control, an instability can be encountered at any given duty cycle. The instability is caused by the current feedback loop. It has been shown that the instability is caused by a double pole at half the switching frequency. If an external ramp (S_e) is added to the on-time ramp (S_n) of the current-sense waveform, stability can be achieved (see Figure 21).

One must be careful not to add too much ramp compensation. If too much is added, the system will start to perform like a voltage mode regulator. All benefits of current mode control will be lost. Figures 29A and 29B show examples of two different ways in which external ramp compensation can be implemented.

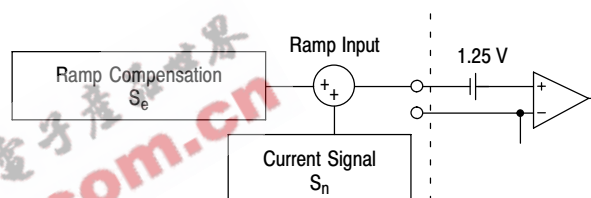

Figure 21. Ramp Compensation

A simple equation can be used to calculate the amount of external ramp necessary to add that will achieve stability in the current loop. For the following equations, the calculated values for the application circuit in Figure 37 are also shown.

$$S_e = \frac{V_O}{L} \left(\frac{N_S}{N_P} \right) (R_S) A_i$$

where: V_O = DC output voltage
 N_P, N_S = number of power transformer primary or secondary turns
 A_i = gain of the current sense network (see Figures 26, 27 and 28)
 L = output inductor
 R_S = current sense resistance

$$\begin{aligned} \text{For the application circuit: } S_e &= \frac{5}{1.8 \mu} \left(\frac{4}{16} \right) (0.3)(0.55) \\ &= 0.115 \text{ V}/\mu\text{s} \end{aligned}$$

MC34025, MC33025

PIN FUNCTION DESCRIPTION

Pin No.	Function	Description
1	Error Amp Inverting Input	This pin is usually used for feedback from the output of the power supply.
2	Error Amp Noninverting Input	This pin is used to provide a reference in which an error signal can be produced on the output of the error amp. Usually this is connected to V_{ref} , however an external reference can also be used.
3	Error Amp Output	This pin is provided for compensating the error amp for poles and zeros encountered in the power supply system, mostly the output LC filter.
4	Clock	This is a bidirectional pin used for synchronization.
5	R_T	The value of R_T sets the charge current through timing Capacitor, C_T .
6	C_T	In conjunction with R_T , the timing Capacitor sets the switching frequency. Because this part is a push-pull output, each output runs at one-half the frequency set at this pin.
7	Ramp Input	For voltage mode operation this pin is connected to C_T . For current mode operation this pin is connected through a filter to the current sensing element.
8	Soft-Start	A capacitor at this pin sets the Soft-Start time.
9	Current Limit/Shutdown	This pin has two functions. First, it provides cycle-by-cycle current limiting. Second, if the current is excessive, this pin will reinitiate a Soft-Start cycle.
10	Ground	This pin is the ground for the control circuitry.
11	Output A	This is a high current totem pole output.
12	Power Ground	This is a separate power ground return that is connected back to the power source. It is used to reduce the effects of switching transient noise on the control circuitry.
13	V_C	This is a separate power source connection for the outputs that is connected back to the power source input. With a separate power source connection, it can reduce the effects of switching transient noise on the control circuitry.
14	Output B	This is a high current totem pole output.
15	V_{CC}	This pin is the positive supply of the control IC.
16	V_{ref}	This is a 5.1 V reference. It is usually connected to the noninverting input of the error amplifier.

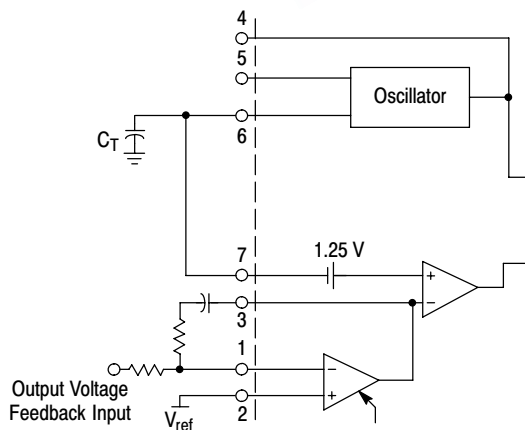

In voltage mode operation, the control range on the output of the Error Amplifier from 0% to 90% duty cycle is from 2.25 V to 4.05 V.

Figure 22. Voltage Mode Operation

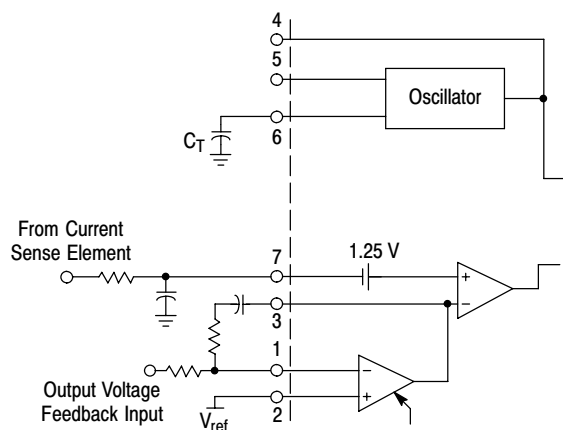

In current mode control, an RC filter should be placed at the ramp input to filter the leading edge spike caused by turn-on of a power MOSFET.

Figure 23. Current Mode Operation

MC34025, MC33025

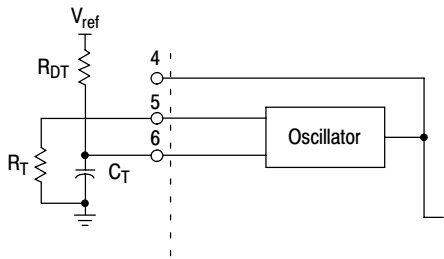

Additional dead time can be added by the addition of a dead time resistor from V_{ref} to C_T . See text on oscillator section for more information.

Figure 24. Dead Time Addition

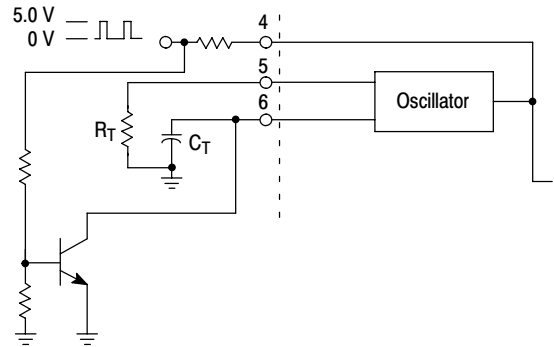

The sync pulse fed into the clock pin must be at least 3.9 V. R_T and C_T need to be set 10% slower than the sync frequency. This circuit is also used in voltage mode operation for master/slave operation. The clock signal would be coming from the master which is set at the desired operating frequency, while the slave is set 10% slower.

Figure 25. External Clock Synchronization

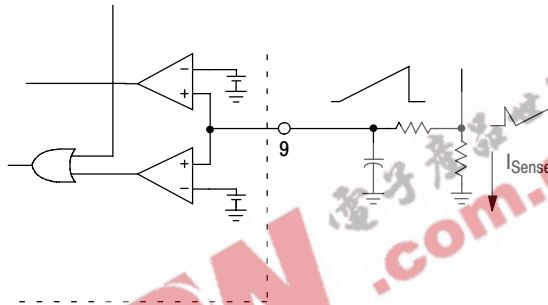

The addition of an RC filter will eliminate instability caused by the leading edge spike on the current waveform. This sense signal can also be used at the ramp input pin for current mode control. For ramp compensation it is necessary to know the gain of the current feedback loop. If a transformer is used, the gain can be calculated by:

$$A_i = \frac{R_{Sense}}{\text{turns ratio}}$$

Figure 26. Resistive Current Sensing

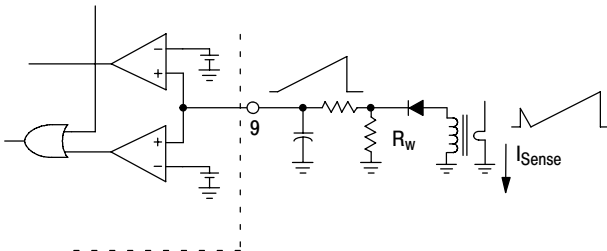

Figure 27. Primary Side Current Sensing

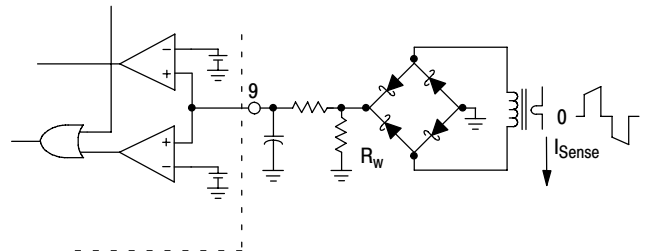
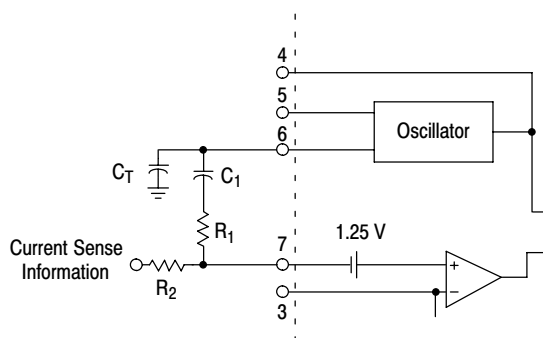

Figure 28. Primary or Secondary Side Current Sensing

The addition of an RC filter will eliminate instability caused by the leading edge spike on the current waveform. This sense signal can also be used at the ramp input pin for current mode control. For ramp compensation it is necessary to know the gain of the current feedback loop. The gain can be calculated by:

$$A_i = \frac{R_w}{\text{turns ratio}}$$

MC34025, MC33025



This method of slope compensation is easy to implement, however, it is noise sensitive. Capacitor C_1 provides AC coupling. The oscillator signal is added to the current signal by a voltage divider consisting of resistors R_1 and R_2 .

Figure 29A. Slope Compensation (Noise Sensitive)



When only one output is used, this method of slope compensation can be used and it is relatively noise immune. Resistor R_M and capacitor C_M provide the added slope necessary. By choosing R_M and C_M with a larger time constant than the switching frequency, you can assume that its charge is linear. First choose C_M , then R_M can be adjusted to achieve the required slope. The diode provides a reset pulse at the ramp input at the end of every cycle. The charge current I_M can be calculated by $I_M = C_M S_e$. Then R_M can be calculated by $R_M = V_{CC}/I_M$.

Figure 29B. Slope Compensation (Noise Immune)

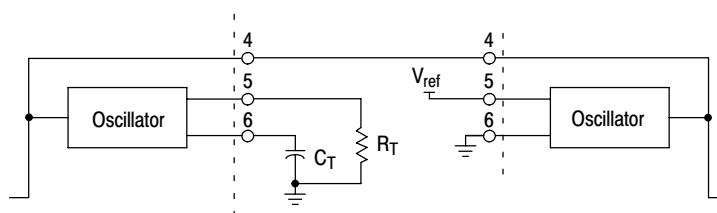

Figure 30. Current Mode Master/Slave Operation Over Short Distances

MC34025, MC33025

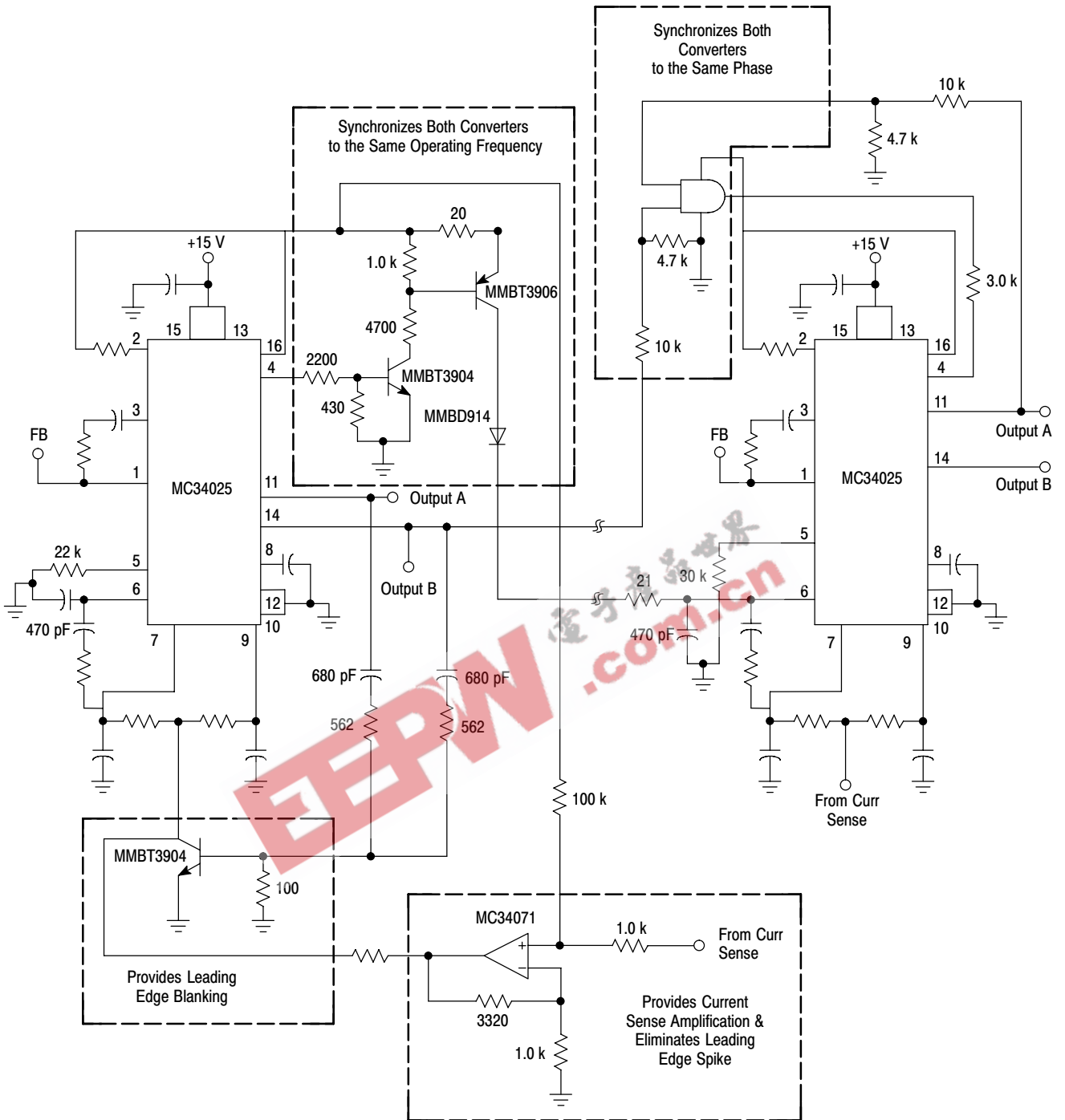
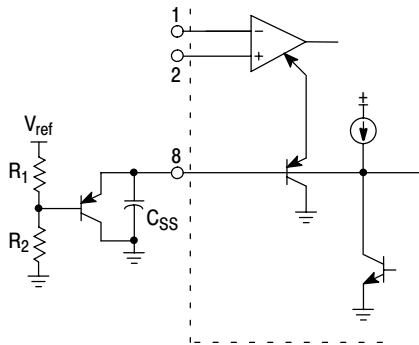

Figure 31. Synchronization Over Long Distances

MC34025, MC33025



In voltage mode operation, the maximum duty cycle can be clamped. By the addition of a PNP transistor to buffer the clamp voltage, the Soft-Start current is not affected by R_1 .

$$\text{The new equation for Soft-Start is } t \approx \frac{V_{\text{clamp}} + 0.6}{9.0 \mu\text{A}} (C_{\text{SS}})$$

In current mode operation, this circuit will limit the maximum voltage allowed at the ramp input to end a cycle.

Figure 32. Buffered Maximum Clamp Level

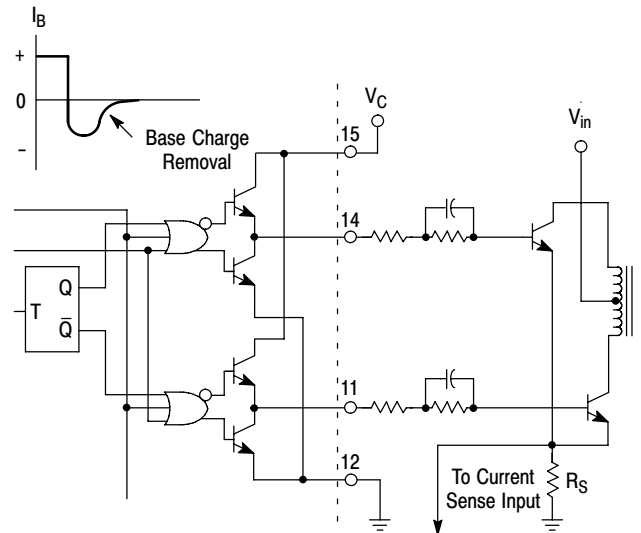

The totem pole output can furnish negative base current for enhanced transistor turn-off, with the addition of the capacitor in series with the base.

Figure 33. Bipolar Transistor Drive

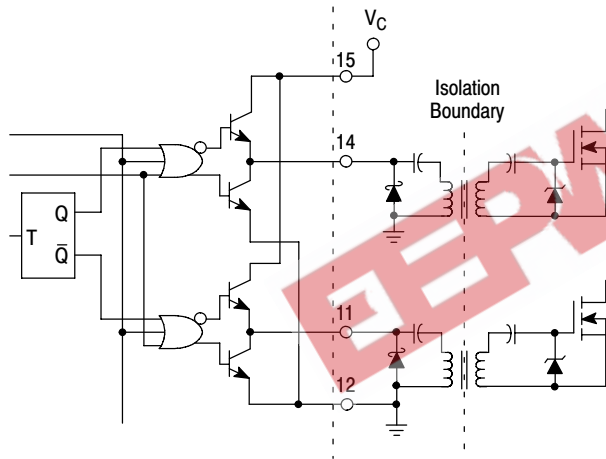

Figure 34. Isolated MOSFET Drive

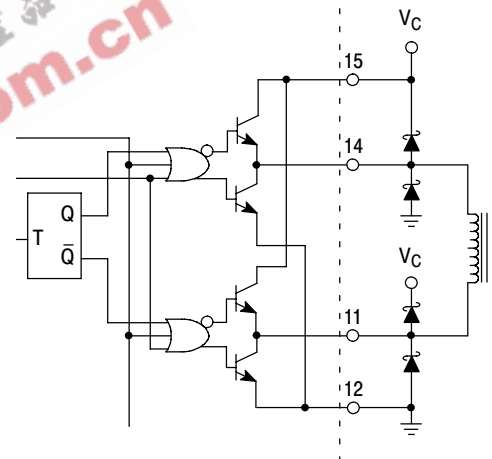

Figure 35. Direct Transformer Drive

The totem pole output can easily drive pulse transformers. A Schottky diode is recommended when driving inductive loads at high frequencies. The diode can reduce the driver's power dissipation due to excessive ringing, by preventing the output pin from being driven below ground.

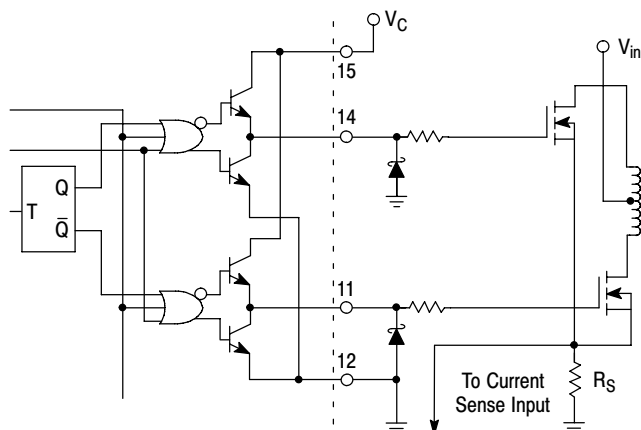
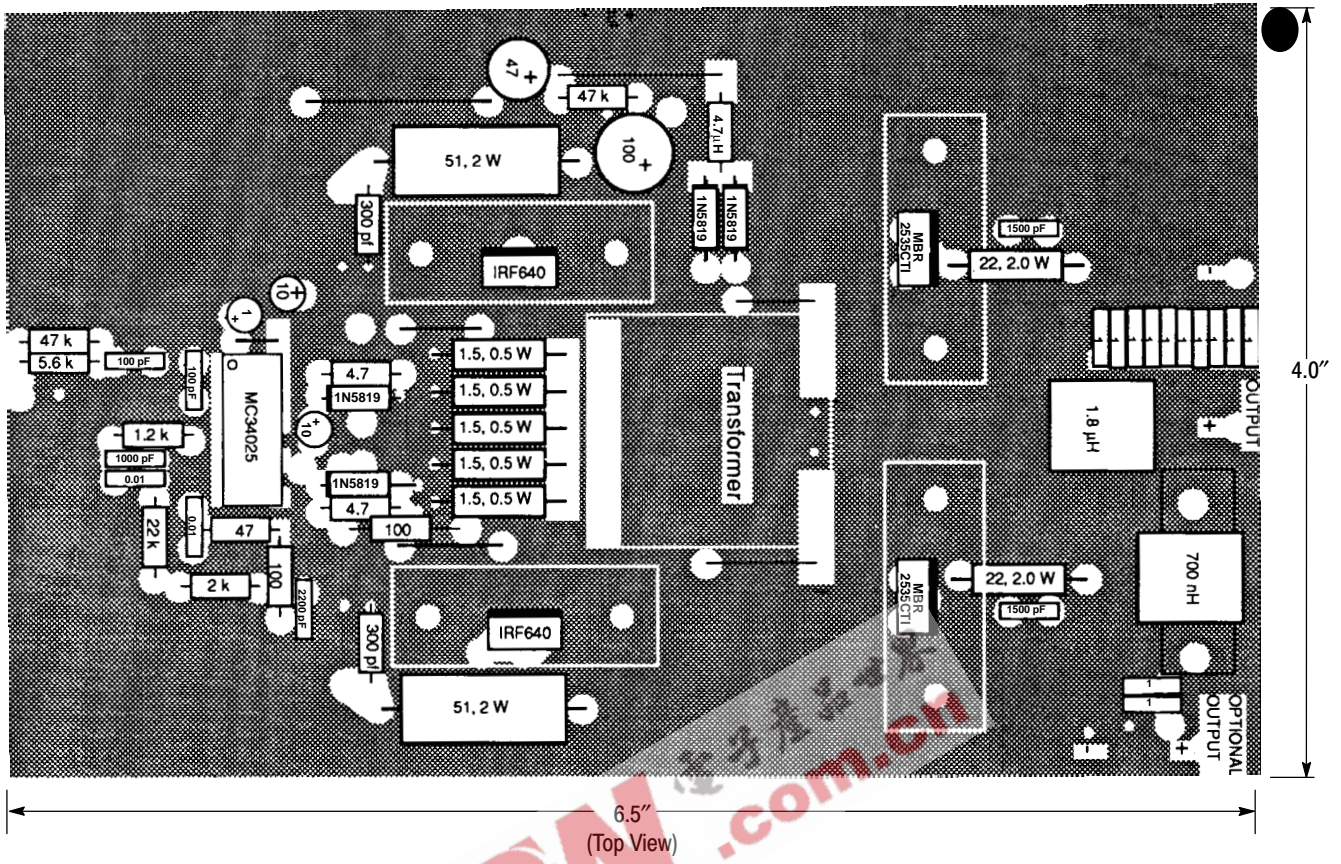

Figure 36. MOSFET Parasitic Oscillations

A series gate resistor may be needed to damp high frequency parasitic oscillation caused by a MOSFET's input capacitance and any series wiring inductance in the gate-source circuit. The series resistor will also decrease the MOSFET's switching speed. A Schottky diode can reduce the driver's power dissipation due to excessive ringing, by preventing the output pin from being driven below ground. The Schottky diode also prevents substrate injection when the output pin is driven below ground.

MC34025, MC33025



MC34025, MC33025

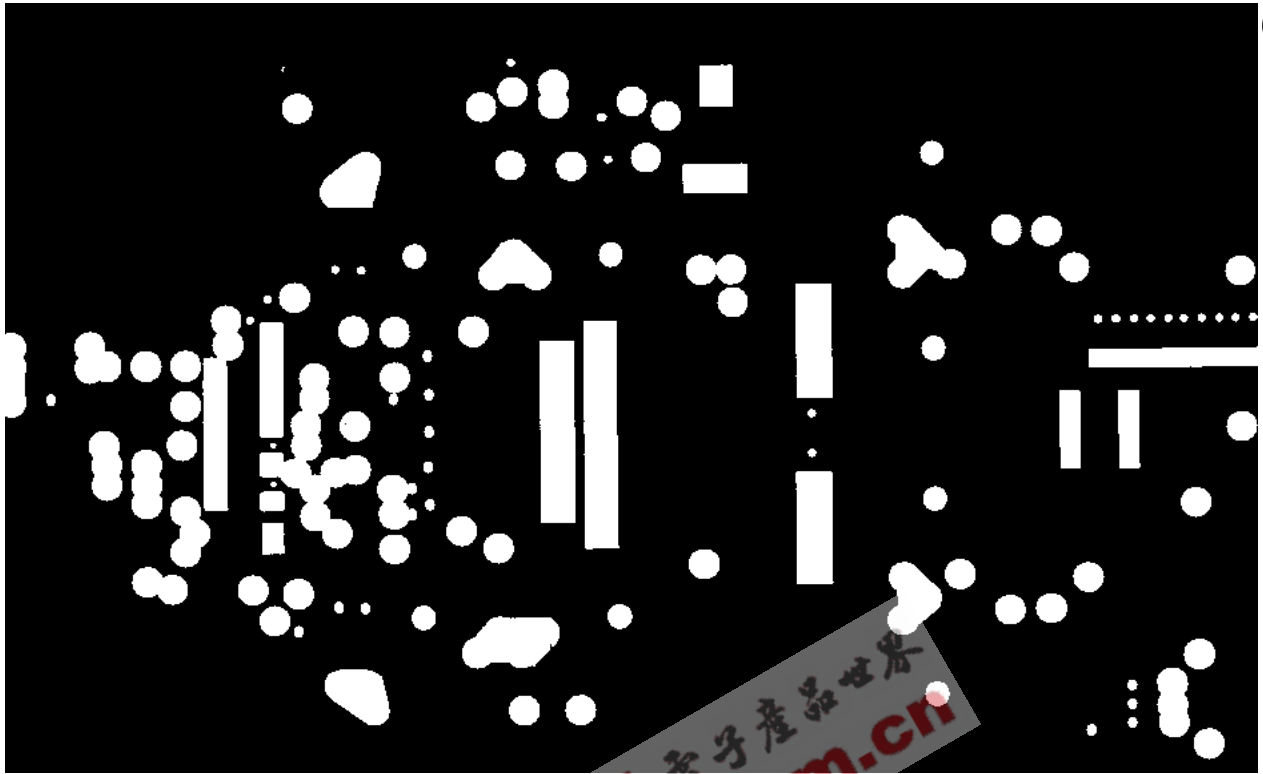

(Top View)

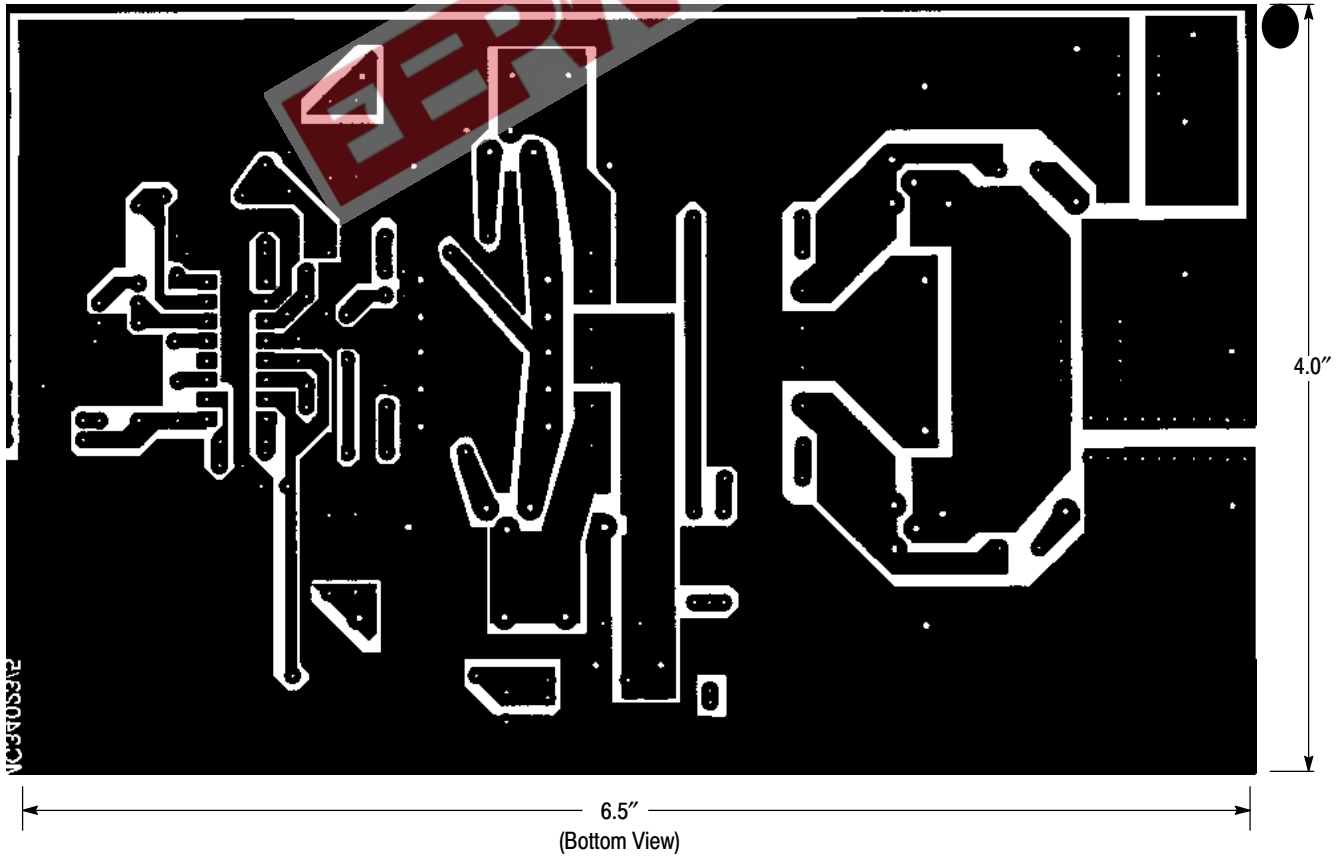

Figure 39. PC Board Without Components

MC34025, MC33025

ORDERING INFORMATION

Device	Package	Shipping [†]
MC33025DW	SOIC-16WB	47 Units / Rail
MC33025DWG	SOIC-16WB (Pb-Free)	47 Units / Rail
MC33025DWR2	SOIC-16WB	1000 Units / Tape & Reel
MC33025DWR2G	SOIC-16WB (Pb-Free)	1000 Units / Tape & Reel
MC33025P	PDIP-16	25 Units / Rail
MC33025PG	PDIP-16 (Pb-Free)	25 Units / Rail
MC34025DW	SOIC-16WB	47 Units / Rail
MC34025DWG	SOIC-16WB (Pb-Free)	47 Units / Rail
MC34025DWR2	SOIC-16WB	1000 Units / Tape & Reel
MC34025DWR2G	SOIC-16WB (Pb-Free)	1000 Units / Tape & Reel
MC34025P	PDIP-16	25 Units / Rail
MC34025PG	PDIP-16 (Pb-Free)	25 Units / Rail

[†]For information on tape and reel specifications, including part orientation and tape sizes, please refer to our Tape and Reel Packaging Specifications Brochure, BRD8011/D.

EEPW.com.cn

MC34025, MC33025

PACKAGE DIMENSIONS

PDIP-16
P SUFFIX
CASE 648-08
ISSUE T

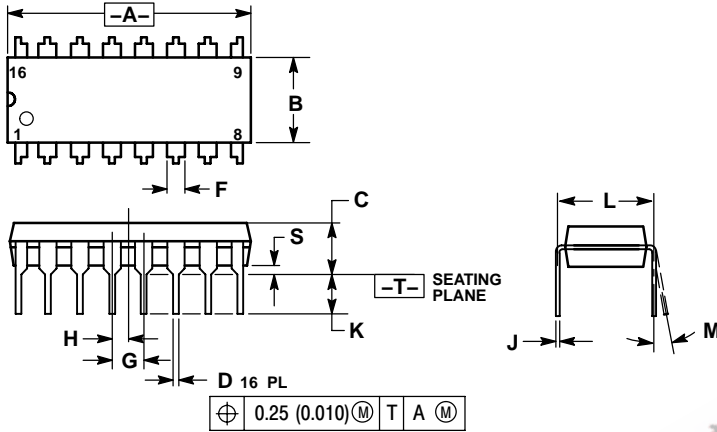

NOTES:

1. DIMENSIONING AND TOLERANCING PER ANSI Y14.5M, 1982.
2. CONTROLLING DIMENSION: INCH.
3. DIMENSION L TO CENTER OF LEADS WHEN FORMED PARALLEL.
4. DIMENSION B DOES NOT INCLUDE MOLD FLASH.
5. ROUNDED CORNERS OPTIONAL.

DIM	INCHES		MILLIMETERS	
	MIN	MAX	MIN	MAX
A	0.740	0.770	18.80	19.55
B	0.250	0.270	6.35	6.85
C	0.145	0.175	3.69	4.44
D	0.015	0.021	0.39	0.53
F	0.040	0.70	1.02	1.77
G	0.100 BSC		2.54 BSC	
H	0.050 BSC		1.27 BSC	
J	0.008	0.015	0.21	0.38
K	0.110	0.130	2.80	3.30
L	0.295	0.305	7.50	7.74
M	0°	10°	0°	10°
S	0.020	0.040	0.51	1.01



MC34025, MC33025

PACKAGE DIMENSIONS

SOIC-16WB
DW SUFFIX
CASE 751G-03
ISSUE C

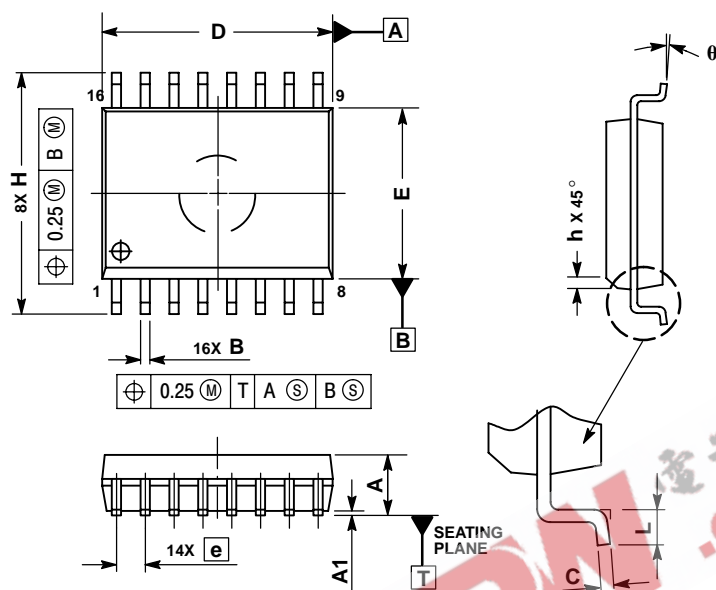

NOTES:

1. DIMENSIONS ARE IN MILLIMETERS.
2. INTERPRET DIMENSIONS AND TOLERANCES PER ASME Y14.5M, 1994.
3. DIMENSIONS D AND E DO NOT INCLUDE MOLD PROTRUSION.
4. MAXIMUM MOLD PROTRUSION 0.15 PER SIDE.
5. DIMENSION B DOES NOT INCLUDE DAMBAR PROTRUSION. ALLOWABLE DAMBAR PROTRUSION SHALL BE 0.13 TOTAL IN EXCESS OF THE B DIMENSION AT MAXIMUM MATERIAL CONDITION.

MILLIMETERS		
DIM	MIN	MAX
A	2.35	2.65
A1	0.10	0.25
B	0.35	0.49
C	0.23	0.32
D	10.15	10.45
E	7.40	7.60
e	1.27 BSC	
H	10.05	10.55
h	0.25	0.75
L	0.50	0.90
q	0°	7°

ON Semiconductor and  are registered trademarks of Semiconductor Components Industries, LLC (SCILLC). SCILLC reserves the right to make changes without further notice to any products herein. SCILLC makes no warranty, representation or guarantee regarding the suitability of its products for any particular purpose, nor does SCILLC assume any liability arising out of the application or use of any product or circuit, and specifically disclaims any and all liability, including without limitation special, consequential or incidental damages. "Typical" parameters which may be provided in SCILLC data sheets and/or specifications can and do vary in different applications and actual performance may vary over time. All operating parameters, including "Typicals" must be validated for each customer application by customer's technical experts. SCILLC does not convey any license under its patent rights nor the rights of others. SCILLC products are not designed, intended, or authorized for use as components in systems intended for surgical implant into the body, or other applications intended to support or sustain life, or for any other application in which the failure of the SCILLC product could create a situation where personal injury or death may occur. Should Buyer purchase or use SCILLC products for any such unintended or unauthorized application, Buyer shall indemnify and hold SCILLC and its officers, employees, subsidiaries, affiliates, and distributors harmless against all claims, costs, damages, and expenses, and reasonable attorney fees arising out of, directly or indirectly, any claim of personal injury or death associated with such unintended or unauthorized use, even if such claim alleges that SCILLC was negligent regarding the design or manufacture of the part. SCILLC is an Equal Opportunity/Affirmative Action Employer. This literature is subject to all applicable copyright laws and is not for resale in any manner.

PUBLICATION ORDERING INFORMATION

LITERATURE FULFILLMENT:

Literature Distribution Center for ON Semiconductor
P.O. Box 61312, Phoenix, Arizona 85082-1312 USA
Phone: 480-829-7710 or 800-344-3860 Toll Free USA/Canada
Fax: 480-829-7709 or 800-344-3867 Toll Free USA/Canada
Email: orderlit@onsemi.com

N. American Technical Support: 800-282-9855 Toll Free
USA/Canada

Japan: ON Semiconductor, Japan Customer Focus Center
2-9-1 Kamimeguro, Meguro-ku, Tokyo, Japan 153-0051
Phone: 81-3-5773-3850

ON Semiconductor Website: <http://onsemi.com>

Order Literature: <http://www.onsemi.com/litorder>

For additional information, please contact your local Sales Representative.