

Low Voltage Subscriber Loop Interface Circuit (SLIC)

Thin Film Silicon Monolithic Integrated Circuit

The MC33121 is designed to provide the interface between the 4-wire side of a central office, or PBX, and the 2-wire subscriber line. Interface functions include battery feed, proper loop termination AC impedance, hookswitch detection, adjustable transmit, receive, and transhybrid gains, and single/double fault indication. Additionally, the MC33121 provides a minimum of 58 dB of longitudinal balance (4-wire and 2-wire).

The transmit and receive signals are referenced to analog ground, while digital signals are referenced to digital ground, easing the interface to codecs, filters, etc. The 2 status outputs (hookswitch and faults) and the Power Down Input are TTL/CMOS compatible. The Power Down Input permits local shutdown of the circuit.

Internal drivers allow the external loop current pass transistors to be standard bipolar transistors (non-Darlington).

The MC33121 is available in a 20 pin DIP and a 28 pin PLCC surface mount package.

- 58 dB Longitudinal Balance Guaranteed; 4-wire and 2-wire
- Transmit, Receive, and Transhybrid Gains Externally Adjustable
- Return Loss Externally Adjustable
- Proper Hookswitch Detection With 30 kΩ Leakage
- Single/Double Fault Indication With Shutdown for Thermal Protection
- Critical Sense Resistors Included Internally
- Standard Power Supplies: - 21.6 V to - 42 V, and + 5.0 V, ± 10%
- On-Hook Transmission
- Power Down Input (TTL and CMOS Compatible)
- Operating Ambient Temperature: - 40°C to + 85°C
- Available in a 20 Pin DIP and 28 Pin PLCC Package

MC33121

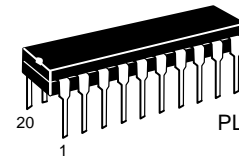

P SUFFIX
PLASTIC PACKAGE
CASE 738

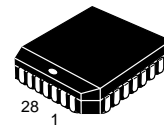

FN SUFFIX
PLCC
CASE 776

ORDERING INFORMATION

Device	Temperature Range	Package
MC33121P	- 40° to + 85°C	Plastic DIP
MC33121FN		PLCC

SIMPLIFIED BLOCK DIAGRAM

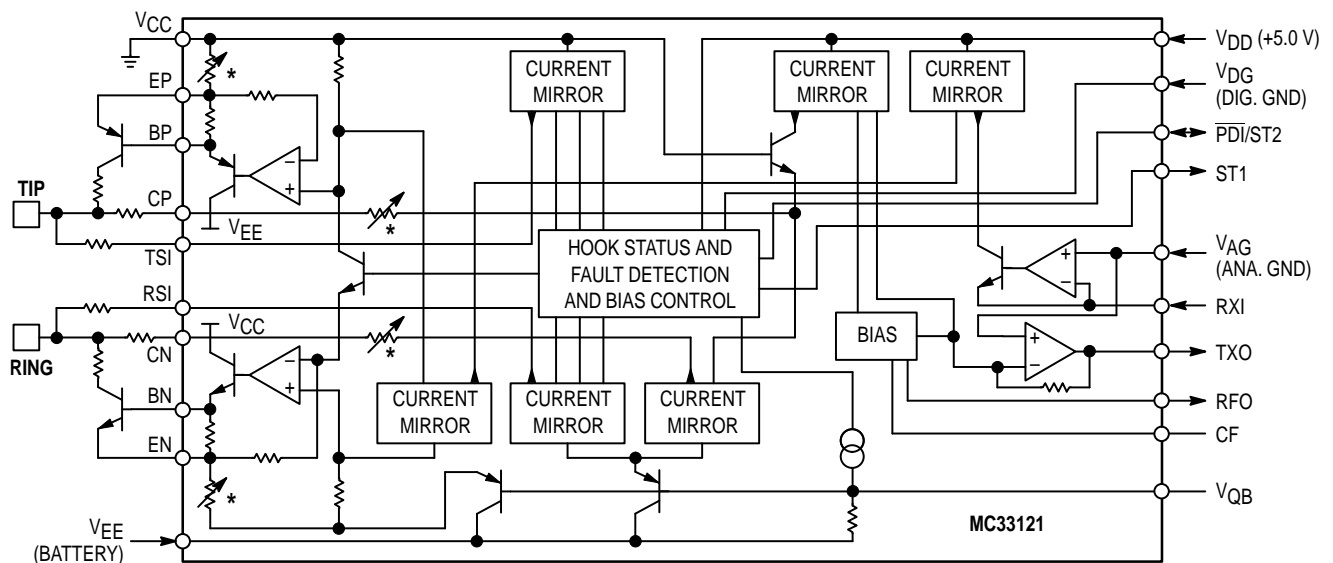

* Indicates trimmed resistor

MAXIMUM RATINGS

Characteristic	Symbol	Value	Unit
Supply Voltage (with respect to V_{CC}) (with respect to V_{DG})	V_{EE} V_{DD}	- 60, + 0.5 - 0.5, + 7.0	Vdc
Voltage @ PDI, (with respect to V_{DG}) @ CP, CN EP, TSI BP RSI, EN BN	V_{in}	- 0.5, + 7.0 $V_{EE} - 0.5, V_{CC} + 0.5$ $V_{CC} - 7.0, V_{CC} + 0.5$ $V_{CC} - 14, V_{CC} + 0.5$ $V_{EE} - 0.5, V_{CC} + 14$ $V_{EE} - 1.0, V_{EE} + 21$	Vdc
Junction Temperature	T_J	150	°C
Storage Temperature	T_{stg}	- 65 to + 150	°C

* Devices should not be operated at these limits. The "Recommended Operating Conditions" table provides for actual device operation.

RECOMMENDED OPERATING CONDITIONS

Characteristic	Symbol	Min	Typ	Max	Unit
Supply Voltage (with respect to V_{CC}) (with respect to V_{DG}) (with respect to V_{CC}) (with respect to V_{CC}) (with respect to V_{AG}) (with respect to V_{EE}) (with respect to V_{CC} and V_{AG})	V_{EE} V_{DD} V_{AG} V_{DG} V_{DD}	- 42 + 4.5 - 3.0 - 3.0 - 3.0 — 3.5	- 24 + 5.0 0 0 0 — —	- 21.6 + 5.5 + 10 + 7.0 + 10 47.5 —	Vdc
Loop Current	I_L	15	—	50	mA
PDI Input Voltage	V_{PDI}	0	—	V_{DD}	Vdc
Sink Current ST1 ST2	I_{ST1L} I_{ST2L}	0 0	— —	1.0 1.0	mA
Transmit Signal Level at Tip & Ring Receive Signal Level at V_{RX}	S_{TX} S_{RX}	- 48 - 48	— —	+ 3.0 + 3.0	dBm
Loop Resistance $V_{EE} = - 42 V$ $V_{EE} = - 24 V$	R_L	0 0	— —	2.0 k 800	Ω
External Transistor Beta	H_{fe}	40	—	500	A/A
Operating Ambient Temperature (See text for derating)	T_A	- 40	—	+ 85	°C

All limits are not necessarily functional concurrently.

ELECTRICAL CHARACTERISTICS

($V_{EE} = - 24 V$, $V_{DD} = + 5.0 V$, unless otherwise noted. $V_{CC} = V_{AG} = V_{DG} = 0 V$, $T_A = 25^\circ C$, see Figure 1.)

Characteristic	Symbol	Min	Typ	Max	Unit
----------------	--------	-----	-----	-----	------

POWER SUPPLIES

V_{EE} Current On Hook ($R_L > 10 M\Omega$, $V_{EE} = - 42 V$) Off Hook ($R_L = 0 \Omega$, $V_{EE} = - 42 V$)*	I_{EEN} I_{EEF}	- 2.7 - 72	- 1.0 - 55	— - 41	mA
V_{DD} Current On Hook ($R_L > 10 M\Omega$, $V_{DD} = + 5.5 V$) Off Hook ($R_L = 0 \Omega$, $V_{DD} = + 5.5 V$)	I_{DDN} I_{DDF}	— 4.0	1.4 7.0	2.7 14	mA
V_{EE} Ripple Rejection $f = 1.0 kHz$, @ V_{TX} (4-wire) $f = 1.0 kHz$, @ Tip/Ring (2-wire)	PSRR	40 40	62 52	— —	dB
V_{DD} Ripple Rejection $f = 1.0 kHz$, @ V_{TX} (4-wire) $f = 1.0 kHz$, @ Tip/Ring (2-wire)		37 37	52 48	— —	

* Includes loop current.

ELECTRICAL CHARACTERISTICS

($V_{EE} = -24\text{ V}$, $V_{DD} = +5.0\text{ V}$, unless otherwise noted. $V_{CC} = V_{AG} = V_{DG} = 0\text{ V}$, $T_A = 25^\circ\text{C}$, see Figure 1.)

Characteristic	Symbol	Min	Typ	Max	Unit
LOOP FUNCTIONS					
Loop Current					mA
Maximum (RRF = 4.7 k, $R_L = 10\ \Omega$)	$I_{L(max)}$	37	41	51	
Nominal (RRF = 4.7 k, $R_L = 367\ \Omega$)	I_L	21	27	34	
Minimum (RRF = 4.7 k, $R_L = 796\ \Omega$)	$I_{L(min)}$	16	17.5	—	
Battery Feed Resistance (RRF = 4.7 k, $R_L = 796\ \Omega$)*	R_{BF}	475	575	675	Ω
Hookswitch Threshold					$k\Omega$
On-to-Off Hook	R_{NF}	2.0	4.1	—	
Off-to-On Hook	R_{FN}	—	7.7	10	
Fault Detection Threshold					Ω
Ring-to-Ground ($R_L = 367\ \Omega$)	R_{RG}	600	1100	—	
Tip-to-Battery ($R_L = 367\ \Omega$)	R_{TB}	600	1100	—	

* Calculated from $[(24/I_{L(min)}) - 796]$

GAIN LEVELS

Transmit Voltage Gain (CP, CN to TXO)	G_{TX1}	—	0.328	—	V/V
Transmit Voltage Gain (V_L/V_{RXI})	G_{TX2}				dB
$V_L = 0\text{ dBm}$, $f = 1.0\text{ kHz}$		-0.3	0	0.3	
$V_L = 0\text{ dBm}$, $f = 3.4\text{ kHz}$, with respect to G_{TX2}		-0.1	0	0.1	
$V_L = +3.0\text{ dBm}$, $f = 1.0\text{ kHz}$, with respect to G_{TX2}		-0.15	0	0.15	
$V_L = -48\text{ dBm}$, $f = 1.0\text{ kHz}$, with respect to G_{TX2}		—	± 0.1	—	
Transmit Distortion (at Pin 11) ($f = 300\text{ Hz}$ to 4.0 kHz , $-40\text{ dBm} \leq V_{T-R} \leq +5.0\text{ dBm}$)	THD_T	—	0.05	—	%
Receive Current Gain (I_{EP}/I_{RXI})	G_{RX1}	94	102	110	mA/mA
Receive Voltage Gain (V_L/V_{RXI}) ($R_L = 600\ \Omega$)	G_{RX2}				dB
$V_{RXI} = 0\text{ dBm}$, $f = 1.0\text{ kHz}$		-0.3	0	0.3	
$V_{RXI} = 0\text{ dBm}$, $f = 3.4\text{ kHz}$, with respect to G_{RX2}		-0.1	0	0.1	
$V_{RXI} = +3.0\text{ dBm}$, $f = 1.0\text{ kHz}$, with respect to G_{RX2}		-0.15	0	0.15	
$V_{RXI} = -48\text{ dBm}$, $f = 1.0\text{ kHz}$, with respect to G_{RX2}		—	± 0.1	—	
Receive Distortion ($f = 300\text{ Hz}$ to 4.0 kHz , $-40\text{ dBm} \leq V_{RXI} \leq +5.0\text{ dBm}$)	THD_R	—	0.05	—	%
Return Loss (Reference = $600\ \Omega$ resistive, $f = 1.0\text{ kHz}$)	RL	30	> 40	—	dB
Transhybrid Rejection ($R_L = 600\ \Omega$ resistive, $f = 1.0\text{ kHz}$, Figure 4)	THR	—	44	—	dB

LONGITUDINAL SIGNALS ($V_{CM} = 1.0\text{ V}_{rms}$, see Figures 1 and 2)

2-Wire Balance, $f = 1.0\text{ kHz}$, $Z_{ac} = 600\ \Omega$ (@ Tip/Ring)	LB	58	64	—	dB
4-Wire Balance, $f = 1.0\text{ kHz}$, $Z_{ac} = 600\ \Omega$ (@ V_{TX})		58	64	—	
2-Wire Balance, $f = 330\text{ Hz}$, $Z_{ac} = 600\ \Omega$ (@ Tip/Ring)		58	64	—	
4-Wire Balance, $f = 330\text{ Hz}$, $Z_{ac} = 600\ \Omega$ (@ V_{TX})		58	64	—	
2-Wire Balance, $f = 3.3\text{ kHz}$, $Z_{ac} = 600\ \Omega$ (@ Tip/Ring)		53	60	—	
4-Wire Balance, $f = 3.3\text{ kHz}$, $Z_{ac} = 600\ \Omega$ (@ V_{TX})		53	60	—	
2-Wire Balance, $f = 1.0\text{ kHz}$, $Z_{ac} = 900\ \Omega$ (@ Tip/Ring)		—	62	—	
4-Wire Balance, $f = 1.0\text{ kHz}$, $Z_{ac} = 900\ \Omega$ (@ V_{TX})		—	62	—	
Signal Balance, $f = 1.0\text{ kHz}$ (Figure 3)		40	55	—	
Longitudinal Impedance, $R_S = 9100\ \Omega$	Z_{Long}	150	180	210	Ω
Maximum Longitudinal Current, per side $f = 1.0\text{ kHz}$, $I_{Loop} = I_{L(min)}$, $C_T = 0.1\ \mu\text{F}$ $V_{EE} = -42$, $V_{CM} = 5.12\text{ V}_{rms}$	$I_{Long(max)}$	8.5	16	—	mA

ELECTRICAL CHARACTERISTICS

($V_{EE} = -24\text{ V}$, $V_{DD} = +5.0\text{ V}$, unless otherwise noted. $V_{CC} = V_{AG} = V_{DG} = 0\text{ V}$, $T_A = 25^\circ\text{C}$, see Figure 1.)

Characteristic	Symbol	Min	Typ	Max	Unit
----------------	--------	-----	-----	-----	------

LOGIC INTERFACE

ST1 Output Voltage Low ($I_{ST1} = 1.0\text{ mA}$, $V_{DD} = 5.5\text{ V}$) High ($I_{ST1} = -100\text{ }\mu\text{A}$, $V_{DD} = 4.5\text{ V}$)	V_{OL}	V_{DG}	0.17	0.4	Vdc
	V_{OH}	2.4	3.2	—	
ST2 Output Voltage Low ($I_{ST2} = 1.0\text{ mA}$, $V_{DD} = 5.5\text{ V}$) High ($I_{ST2} = -100\text{ }\mu\text{A}$, $V_{DD} = 4.5\text{ V}$)	V_{OL}	V_{DG}	0.17	0.4	
	V_{OH}	2.4	4.3	—	
Time Delay Hookswitch Closure to ST1 Change Hookswitch Opening to ST1 Change Hookswitch Closure to 90% of Loop Current ($C_T = 0.1\text{ }\mu\text{F}$) PDI Taken High-to-Low to 10% of Loop Current PDI Taken Low-to-High to 90% of Loop Current	t_{ST11}	—	10	—	μs
	t_{ST12}	—	200	—	
	t_{HS}	—	19	—	ms
	t_{ST21}	—	18	—	ms
PDI Input Current $V_{PDI} = 3.0\text{ V}$, $R_L = 367\text{ }\Omega$, $V_{DD} = 5.0\text{ V}$ $V_{PDI} = 0\text{ V}$, $R_L = 367\text{ }\Omega$, $V_{DD} = 5.5\text{ V}$	I_{IH}	—	—	—	μA
		-1250	-800	-300	
PDI Input Voltage Low High	V_{IL} V_{IH}	V_{DG}	—	0.8	Vdc
		2.0	—	V_{DD}	

MISCELLANEOUS

V_{QB} Voltage ($V_{QB} - V_{EE}$) @ $I_L = 20\text{ mA}$ @ $I_L = 40\text{ mA}$	V_{QB}	—	0.82	—	Vdc
		—	0.95	—	
TXO Offset Voltage ($V_{TXO} - V_{AG}$) @ $R_L = 600\text{ }\Omega$	V_{TXO}	-400	+30	+400	mVdc
TXO Output Current	I_{TXO}	± 275	± 800	—	$\mu\text{A pk}$
RXI Offset Voltage ($V_{RXI} - V_{AG}$) @ $R_L = 600\text{ }\Omega$	V_{RXOS}	—	0.8	—	mVdc
V_{AG} Input Current @ $R_L = 600\text{ }\Omega$	I_{VAG}	—	0.2	—	μA
Idle Channel Noise (with C-message filter, $R_L = 600\text{ }\Omega$) @ TXO (Pin 11) @ Tip/Ring	N_{IC4} N_{IC2}	—	-10	—	dBmc
		—	-5.0	—	
Thermal Resistance — Junction to Ambient (Either package, in still air, soldered to a PC board)	θ_{JA}	(@ $T_A = +25^\circ\text{C}$)	—	62	$^\circ\text{C/W}$
		(@ $T_A = +85^\circ\text{C}$)	—	36	

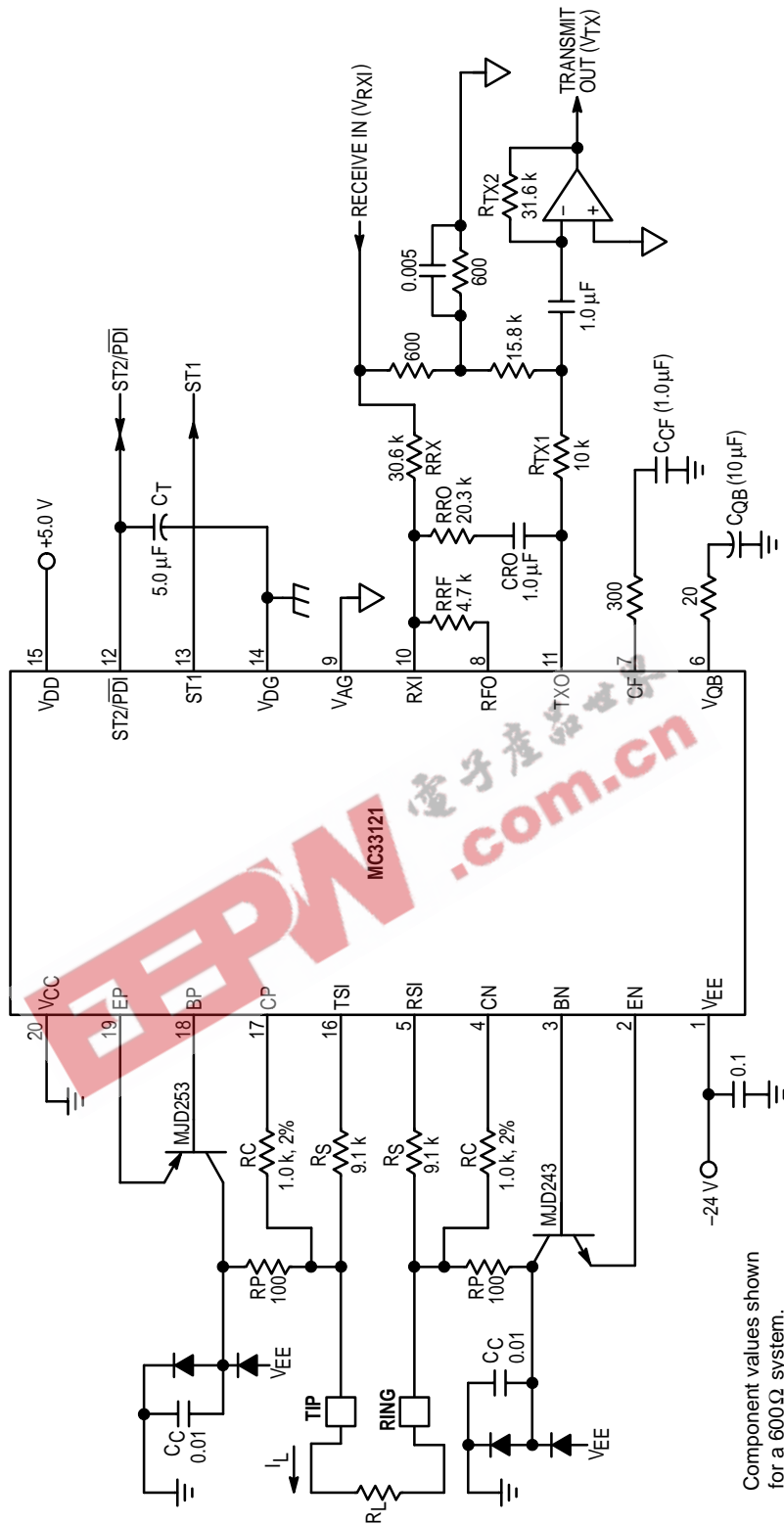

Figure 4. Application Circuit

Component values shown for a 600Ω system.

PIN FUNCTION DESCRIPTION

Symbol	Pin		Description
	DIP	PLCC	
V _{CC}	20	28	Connect to noise-free battery ground. Carries loop current and some bias currents.
EP	19	27	Connect to the emitter of the PNP pass transistor.
BP	18	26	Connect to the base of the PNP pass transistor.
CP	17	24	Connect to TIP through a current limiting protection resistor (R _C). CP is the noninverting input to the internal transmit amplifier (Figure 28). Input impedance is 31 k Ω .
TSI	16	23	Sense input. Connect to TIP through a current limiting protection resistor (R _S) which also sets the longitudinal impedance. Input impedance is \approx 100 Ω to V _{CC} .
V _{DD}	15	22	Connect to a + 5.0 V, \pm 10% supply, referenced to digital ground. Powers logic section and provides some bias currents for the loop current drivers.
V _{DG}	14	20	Digital Ground. Reference for ST1, ST2 and V _{DD} . Connect to system digital ground.
ST1	13	18	Status Output (TTL/CMOS). Indicates hook switch status — high when on-hook, low when off-hook, and pulse dialing information. Used with ST2 to indicate fault conditions.
ST2/PDI	12	17	Status output and an input (TTL/CMOS). As an output, ST2 can indicate hook status — Low when on-hook, high when off-hook. Used with ST1 to indicate fault conditions. As an input, it can be taken low (when off-hook) to deny subscriber loop current.
TXO	11	16	Transmit voltage output. Amplitude is \approx 1/3 that across CP and CN. Nominally capable of 800 μ A output current. DC referenced to V _{AG} .
RXI	10	14	Receive current input. Current at this pin is multiplied by 102 at EP and EN to generate loop current. RXI is a virtual ground at V _{AG} level. Current flow is out of this pin.
V _{AG}	9	13	Analog ground, reference for TXO and RXI. Connect to system analog ground. Current flow is into this pin.
RFO	8	12	A resistor from this pin and RXI sets the maximum loop current and DC feed resistance. Minimum resistor value is 3.3 k (see Figures 5 to 7).
CF	7	10	A low leakage capacitor between this pin and V _{AG} provides DC and AC signal separation. A series resistor is required for battery supply turn-on/off transient protection (Figure 4).
V _{QB}	6	8	Quiet Battery. A capacitor between V _{QB} and V _{CC} filters noise and ripple from V _{EE} , providing a quiet battery source for the speech amplifiers. A series resistor is required for battery supply turn-on/off transient protection (Figure 4).
RSI	5	7	Sense input. Connect to RING through a current limiting protection resistor which also sets the longitudinal impedance. Input impedance is \approx 100 Ω to V _{QB} .
CN	4	6	Connect to RING through a current limiting protection resistor. CN is the inverting input to the internal transmit amplifier (Figure 28). Input impedance is 31 k Ω .
BN	3	4	Connect to the base of the NPN pass transistor.
EN	2	3	Connect to the emitter of the NPN pass transistor.
V _{EE}	1	2	Connect to battery voltage (– 21.6 V to – 42 V).

(Pins 1, 5, 9, 11, 15, 19, 21, and 25 are not internally connected on the PLCC package.)

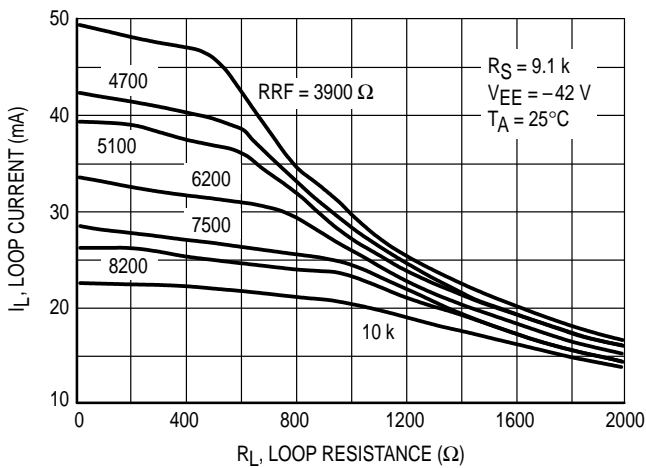

Figure 5. Loop Current versus Loop Resistance and RRF

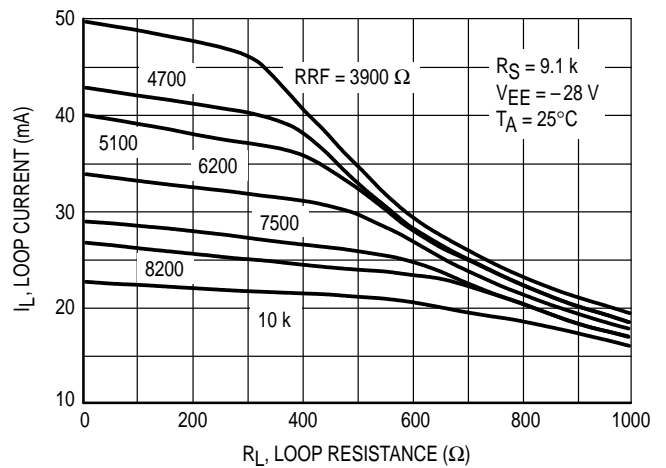

Figure 6. Loop Current versus Loop Resistance and RRF

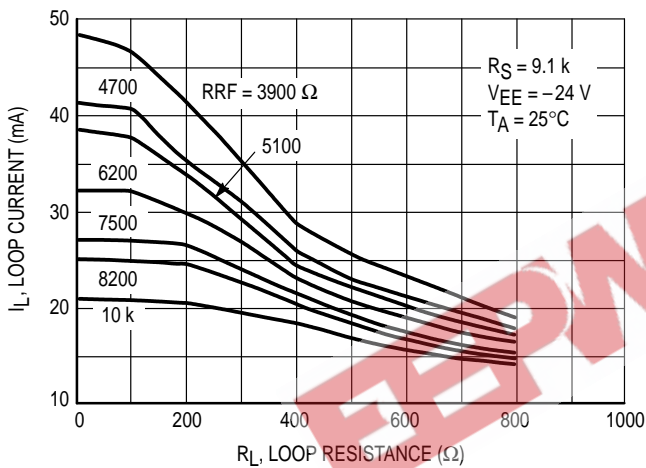

Figure 7. Loop Current versus Loop Resistance and RRF

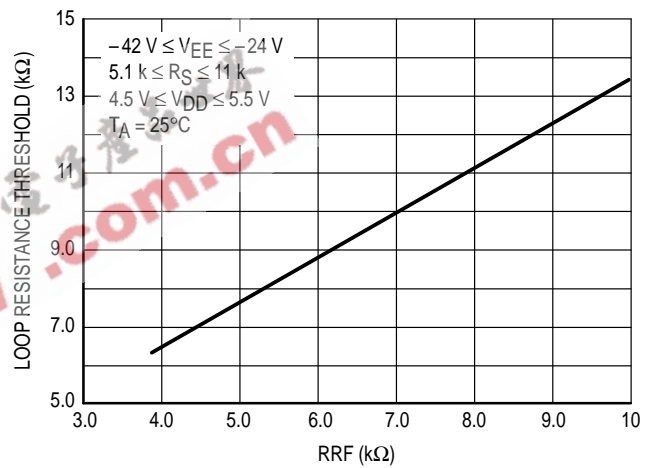

Figure 8. Off-Hook to On-Hook Threshold versus RRF

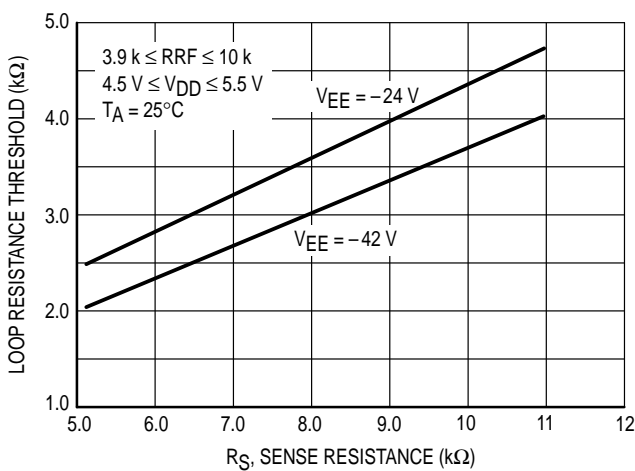

Figure 9. On-Hook to Off-Hook Threshold versus R_S

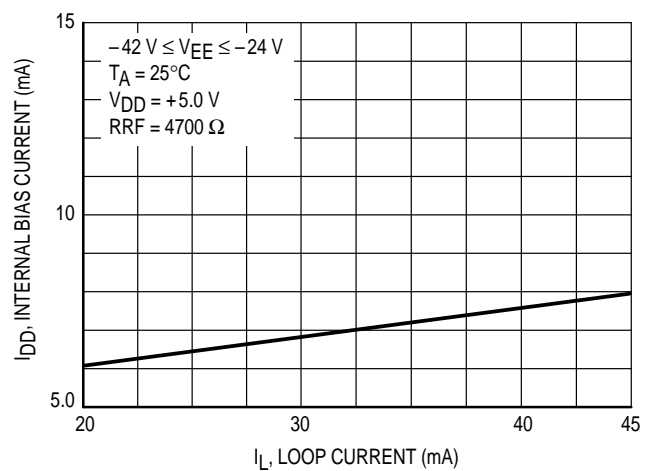

Figure 10. I_{DD} versus Loop Current

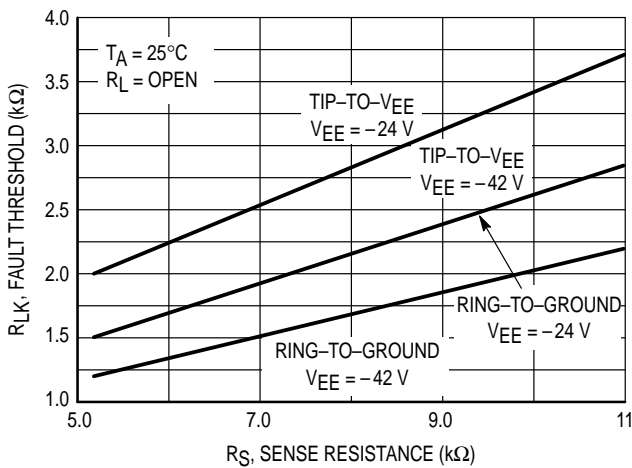

Figure 11. Fault Threshold (On-Hook) versus R_S

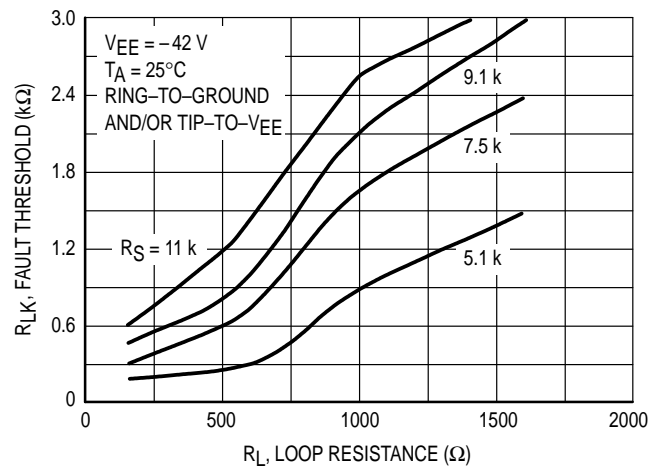

Figure 12. Fault Threshold (Off-Hook) versus Loop Resistance

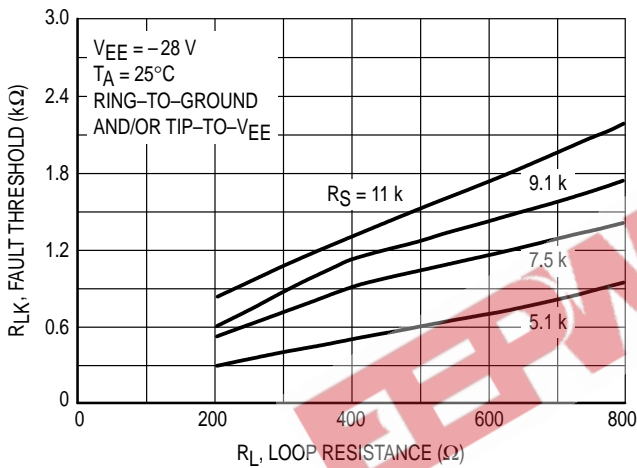

Figure 13. Fault Threshold (Off-Hook) versus Loop Resistance

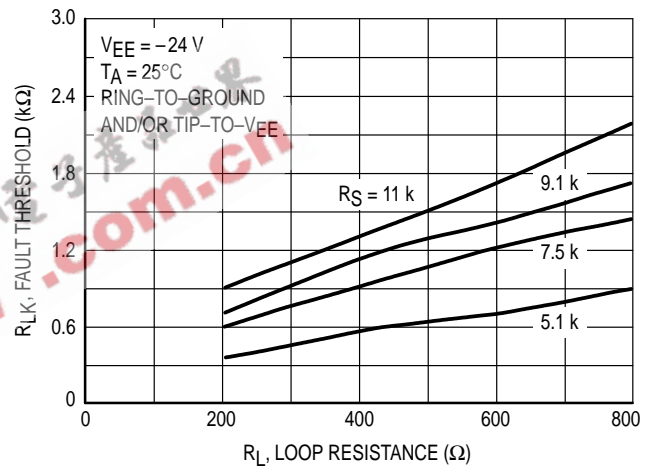

Figure 14. Fault Threshold (Off-Hook) versus Loop Resistance

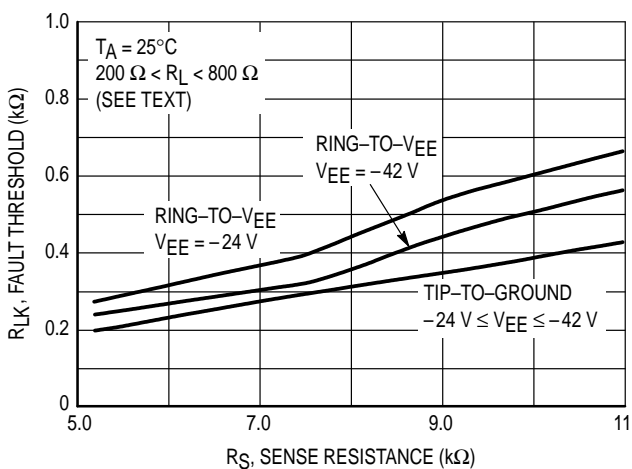

Figure 15. Fault Threshold (Off-Hook) versus R_S

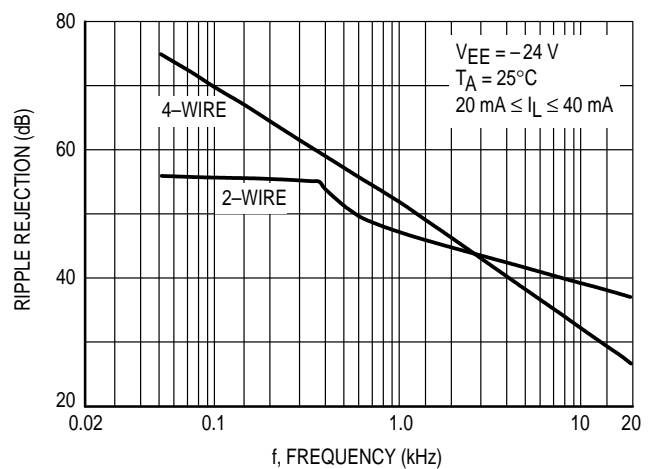

Figure 16. V_{DD} Ripple Rejection versus Frequency

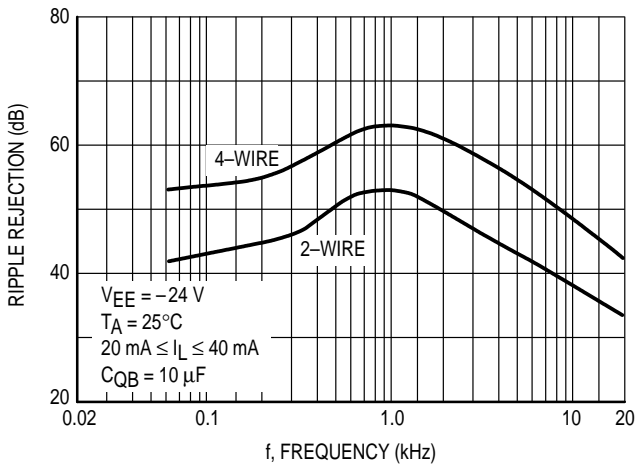

Figure 17. V_{EE} Ripple Rejection versus Frequency

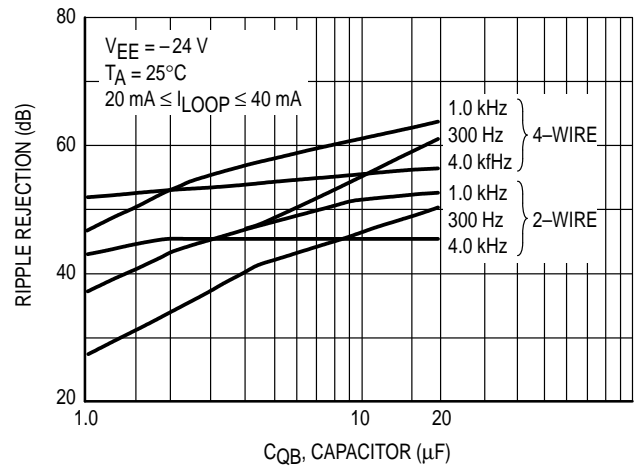

Figure 18. V_{EE} Ripple Rejection versus Frequency and C_{QB}

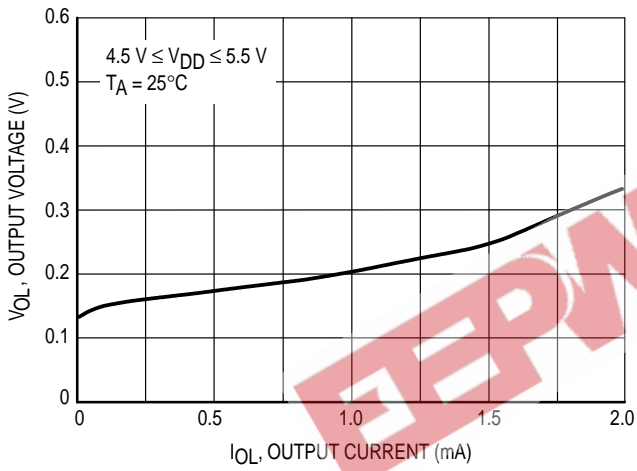

Figure 19. ST1, V_{OL} versus I_{OL}

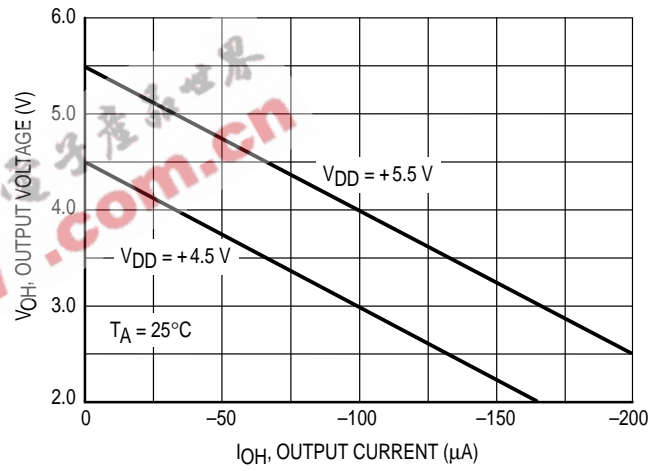

Figure 20. ST1, V_{OH} versus I_{OH}

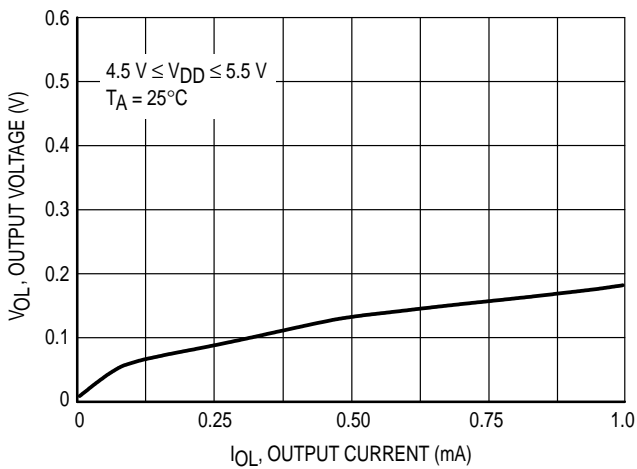

Figure 21. ST2, V_{OL} versus I_{OL}

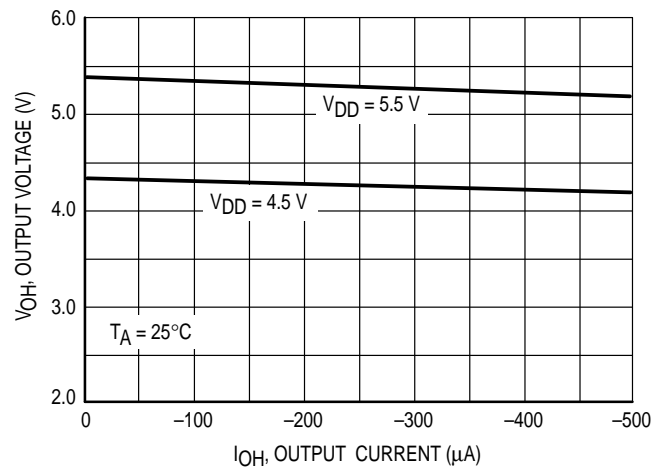

Figure 22. ST2, V_{OH} versus I_{OH}

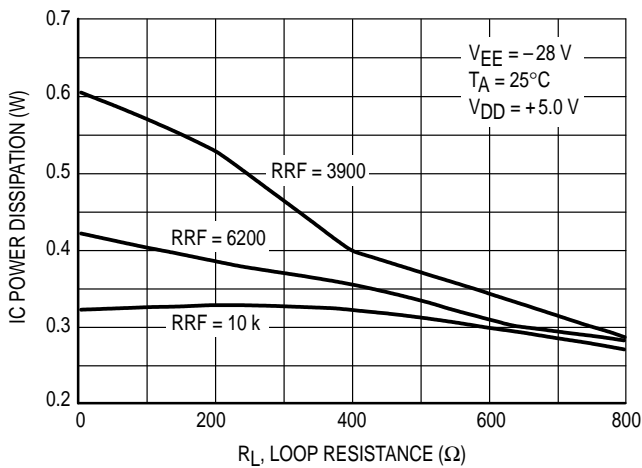

Figure 23. IC Power Dissipation versus Loop Resistance and RRF

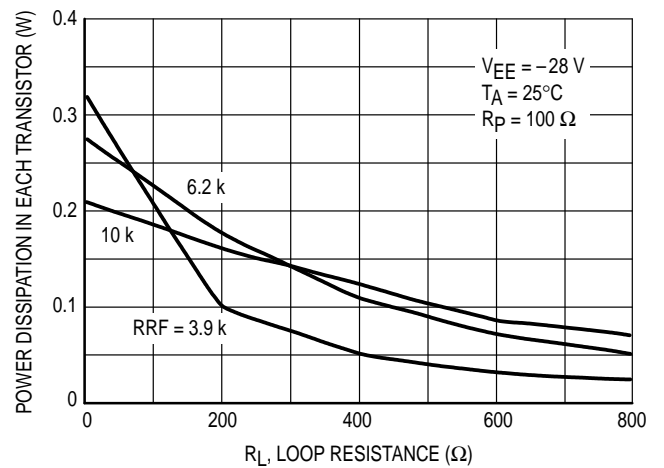

Figure 24. Transistor Power Dissipation versus Loop Resistance and RRF

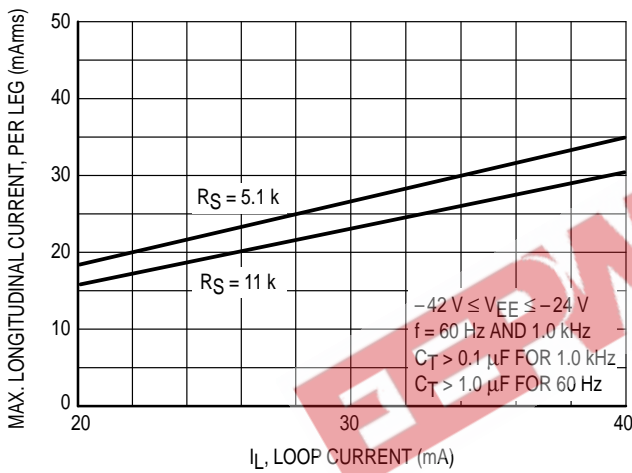

Figure 25. Maximum Longitudinal Current versus Loop Current

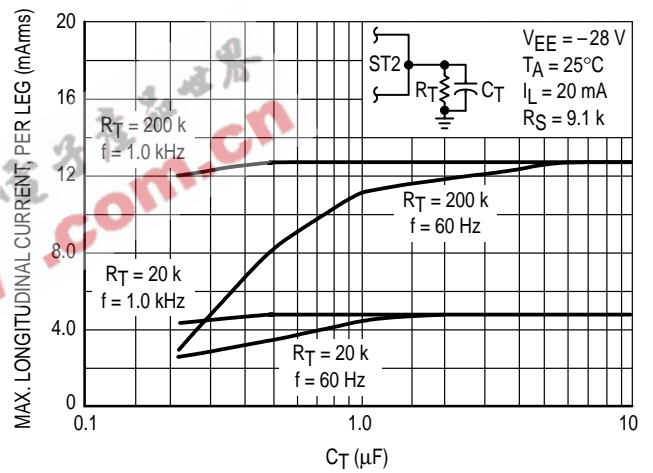

Figure 26. Maximum Longitudinal Current versus C_T , R_T and Frequency

Figure 27 is representative of the DC loop current path (bold lines). On a long line ($R_L > 400 \Omega$), the loop current can be determined from the following equation:

$$I_L = \frac{(|V_{EE}| - 3.6 \text{ V}) \cdot 13}{RRF + \{(R_L + 5) \cdot 13\}} \quad (1)$$

On short lines ($R_L < 400 \Omega$), the three diodes across the 12.4 k resistor clamp the voltage at RFO, thereby preventing the RXI current from increasing as the load resistance is decreased. The maximum loop current is:

$$I_{L(\max)} = \frac{1.85 \text{ V} \cdot 102}{RRF} \quad (T_A = 25^\circ\text{C}) \quad (2)$$

Due to the temperature dependence of a diode's forward voltage, the maximum loop current will change with temperature by $\approx -0.3\%/^\circ\text{C}$.

The battery feed resistance ($\Delta V_{TIP}/\Delta I_L$) is $\approx 400 \Omega$, but depends on the loop current, V_{EE} , RRF, and is a valid parameter only on long lines where the current limit is not in effect. On short lines, the feed resistance is high since the loop current is clamped at a near constant level. The AC impedance (Return Loss) however, is not determined nor affected by the DC parameters. See the Applications Section for Return Loss information.

Transmit Path

The transmit path, shown in Figure 28, consists of an internal amplifier which has inputs at CP and CN, and its output at TXO. The gain is internally fixed at 0.328 V/V (-9.7 dB). The output is in phase with the signal at CP (normally the same as TIP), and is out of phase with the signal at CN. The signal at TXO is also out of phase with that at V_{RX} , the receive signal input, described in another section.

The TXO output can swing $\approx 3.0 \text{ V}_{p-p}$, with a nominal current capability of $\pm 800 \mu\text{A}$ peak ($\pm 275 \mu\text{A}$ minimum). The load on TXO is the parallel combination of RTX1 and the RRO network (described later). TXO is nominally internally biased at the V_{AG} DC level, but has an offset which varies with loop current.

In normal applications, the signal at CP/CN is reduced slightly from that at Tip/Ring by the voltage divider composed of the external RC resistors, and the internal 31 k resistors. The value of the RC resistors depends on the transient

protection needed, described in another section, with 1.0 k Ω resistors being suitable for most applications. The resulting signal at TXO needs to be gained up to obtain 0 dB from Tip/Ring to V_{TX} (the 4-wire output). The common method involves an external op amp, as shown in Figure 28, with a gain of RTX2/RTX1. The gain from V_L to V_{TX} is:

$$\frac{V_{TX}}{V_L} = \frac{RTX2 \cdot 31 \text{ k} \cdot 0.328}{RTX1 \cdot (RC + 31 \text{ k})} \quad (3)$$

If a codec/filter is used, many of which include an internal op amp, a separate op amp is not needed. CTX is primarily for DC blocking (of the TXO offset), and is usually large (1.0 μF) so as to not affect the gain.

Receive Path

The receive path, shown in Figure 29, consists of the input at RXI, the transistor driver amplifiers, the external transistors, and the load at Tip/Ring.

RXI is a virtual ground (DC level = V_{AG}) and is a current input. Current flow is out of the pin. The RXI current is mirrored to the two transistor drivers which provide a gain of 102. The two external transistors are then two current sources, in series, operating at the same value. An additional internal circuit (not shown) balances the two current sources to maintain operation in their linear region.

The load current (through R_L) is slightly different from the transistor current due to the sense resistors RC and RS. The sense resistors add to the DC loop current, but subtract from the AC load current.

In normal operation, the current at RXI is composed of a DC current (from RFO), an AC current (from V_{RX}) which is the receive signal, and an AC current from TXO, which is the feedback signal to set the return loss (setting the return loss is discussed in the section on AC Terminating Impedance). The resulting AC signal at Tip is inverted from that at V_{RX} , while the signal at Ring is in phase with V_{RX} .

The resistors RP are for transient protection, and their value (defined in another section) depends on the amount of protection required. A nominal value of 100 Ω is suitable for most applications.

The system receive gain, from V_{RX} to Tip/Ring, is not described in this section since in normal applications, it involves the feedback which sets the AC terminating impedance. The Applications Section discusses these in detail.

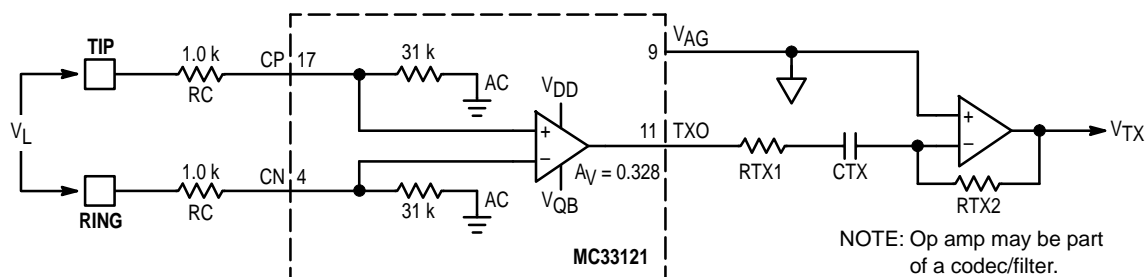

Figure 28. Transmit Path

Logic Interface (Hook status, pulse dialing, faults)

The logic interface section provides hookswitch status, fault information, and pulse dialing information to the 4-wire side of the system at the ST1 and ST2 outputs. Figure 30 is a representative diagram.

The logic outputs operate according to the truth table in Table 1:

Table 1. Status Output Truth Table

Hook Status	Fault Detection	Outputs		Circuit Condition
		ST1	ST2	
On-Hook	No Fault	Hi	Lo	Internally powered down
Off-Hook	No Fault	Lo	Hi	Powered up
On-Hook	Fault	Lo	Lo	Internally powered down
Off-Hook	Fault	Lo	Lo	Internally powered down

Referring to Figure 30, ST1 is configured as an active NPN pull-down with a 15 kΩ pullup resistor. ST2 has a 800 μA

current source pullup, and a 1.0 mA current source for a pull-down. Current limiting this output controls the discharge from the external capacitor when ST2 switches low.

The condition where both ST1 and ST2 are high is not valid, but may occur momentarily during an off-hook to on-hook transition. The condition where both ST1 and ST2 are low may occur momentarily during an on-hook to off-hook transition — this should not be interpreted as a fault condition. ST1 and ST2 are TTL/CMOS compatible and are powered by the + 5.0 V supply (VDD). Refer to the Applications Section for more details.

Power Supplies, Grounds

The MC33121 requires 2 power supplies: battery voltage between - 21.6 V and - 42 V (V_{EE}), and an auxiliary voltage between + 4.5 V and + 5.5 V (V_{DD}).

V_{EE} is nominally - 24 V, with a typical range of - 21.6 V to - 42 V, and must be referenced to V_{CC} (battery ground). A 0.1 μF bypass capacitor should be provided between V_{CC}

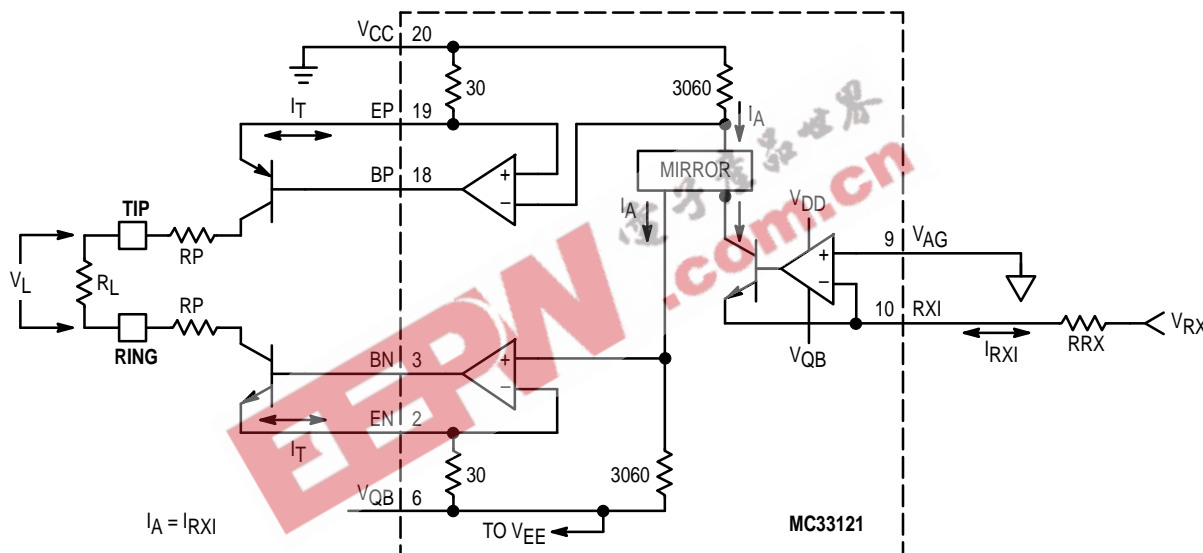

Figure 29. Receive Path

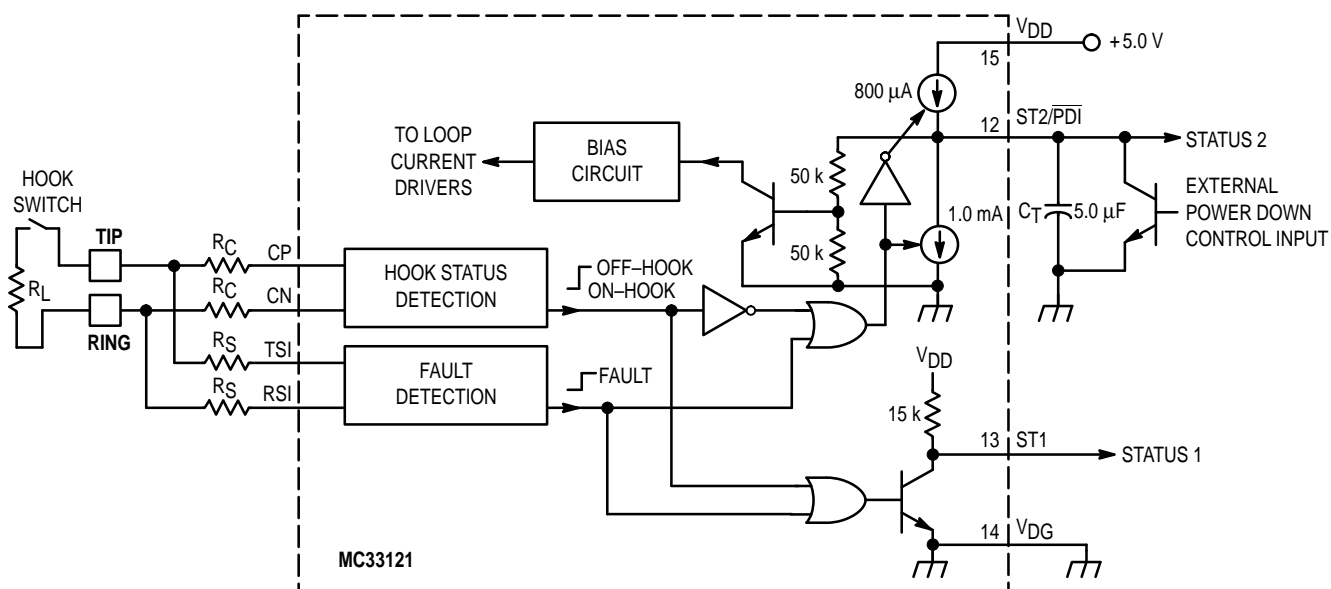

Figure 30. Logic Interface

and V_{EE} . The V_{EE} current (I_{EE}) is nominally 1.0 mA when on-hook, 8.0 to 12 mA more than the loop current when off-hook, and ≈ 5.0 mA when off-hook but powered down by using the PDI pin. Ripple and noise rejection from V_{EE} is a minimum of 40 dB (with a 10 μ F capacitor at V_{QB}), and is dependent on the size and quality of the V_{QB} capacitor (C_{QB}) since V_{QB} is the actual internal supply voltage for the speech amplifiers. The absolute maximum for V_{EE} is -60 V, and should not be exceeded by the combination of the battery voltage, its tolerance, and its ripple.

V_{DD} is normally supplied from the line card's digital + 5.0 V supply, and is referenced to V_{DG} (digital ground). A 0.1 μ F capacitor should be provided between V_{DD} and V_{DG} . The V_{DD} current (I_{DD}) is nominally 1.7 mA when on-hook and between 6.0 and 8.0 mA when off-hook (see Figure 10). When the MC33121 is intentionally powered down using the PDI pin, I_{DD} changes by < 1.0 mA from the normal off-hook value.

V_{AG} is the analog ground for the MC33121, and is the reference for the speech signals (RXI and TXO). Current flow is **into** the pin, and is typically < 0.5 μ A.

Normally, V_{CC} , V_{DG} and V_{AG} are to be at the same DC level. However, if strong transients are expected at Tip and Ring, as in a Central Office application, or any application where the phone line is outdoors, V_{CC} should not be connected directly to V_{DG} and V_{AG} in order to prevent possible damage to the + 5.0 V system. The MC33121 is designed to tolerate as much as ± 30 V between V_{CC} and the other two grounds on a transient basis only. This feature permits V_{CC} and the other grounds to be kept separate (on an AC basis) on the line card by transient suppressors, or to be connected together farther into the system (at the power supplies). See the Applications Section on ground arrangements and transient protection for further information on connecting the MC33121 to the system supplies.

APPLICATIONS INFORMATION

This section contains information on the following topics:

Design Procedure	pg. 15
Power Dissipation Calculations and Considerations	pg. 22
Selecting the Transistors	pg. 23
Longitudinal Current Capability	pg. 23
PC Board Layout Considerations	pg. 23
Alternate Circuit Configurations	pg. 26

Design Procedure

This section describes the step-by-step sequence for designing in the MC33121 SLIC into a typical line card application for either a PBX or Central Office. The sequence is important so that each new component value which is calculated does not affect components previously determined. Figure 4 (Typical Application Circuit) is the reference circuit for most of this discussion. The recommended sequence (detailed below), consists of establishing the DC aspects first, and then the AC aspects:

- 1) Determine the maximum loop current for the shortest line, select RRF. Power dissipation must be considered here.
- 2) Select the main protection resistors (RP), and diodes, based on the expected transient voltages. Transient protection configuration must also be considered here.
- 3) Select RC based on the expected transient voltages.
- 4) Select RS based on the desired longitudinal impedance at Tip and Ring. Transient voltages are also a factor here.
- 5) Calculate RRO based on the desired AC terminating impedance (return loss).
- 6) Calculate RRX based on the desired receive gain.
- 7) Calculate RTX2 and RTX1 based on the desired transmit gain.
- 8) Calculate the balance resistor (RB), or network, as appropriate for desired transhybrid rejection.
- 9) Logic Interface

Preliminary

There is a primary AC feedback loop which has its main sense points at CP and CN (see Figure 34). The loop extends from there to TXO, through RRO to RXI, through the internal amplifiers to the transistor drivers, through RP to Tip

and Ring, and through the RCs to CP and CN. Components within this loop, such as RP, RC, the transistors, and the compensation capacitors need not be tightly matched to each other in order to maintain good longitudinal balance. The tolerance requirements on these components, and others, are described in subsequent sections. Any components, however, which are placed outside the loop for additional line card functions, such as test relay contacts, fuses, resistors in series with Tip and Ring, etc. will affect longitudinal balance, signal balance, and gains if their values and mismatch is not carefully considered. The MC33121 cannot compensate for mismatch among components outside the loop.

The compensation capacitors (0.01 μ F) shown at the transistor collectors (Figure 4) compensate the transistor driver amplifiers, providing the required loop stability. The required tolerance on these capacitors can be determined from the following guidelines:

- A 10% mismatch ($\pm 5\%$ tolerance) will degrade the longitudinal balance by ≈ 1.0 dB on a 60 dB device, and by ≈ 3.0 dB on a 70 dB device.
- A 20% mismatch ($\pm 10\%$ tolerance) will degrade the longitudinal balance by ≈ 3.0 dB on a 60 dB device, and by ≈ 6.0 dB on a 70 dB device.

High quality ceramic capacitors are recommended since they serve the secondary function of providing a bleedoff path for RF signals picked up on the phone line. These capacitors should be connected to a good quality RF ground.

The capacitors used at C_{QB} and C_F must be low leakage to obtain proper performance. Leakage at the C_{QB} capacitor will affect the DC loop current characteristics, while leakage at the C_F capacitor will affect the AC gain parameters, and possibly render the IC inoperative.

1) Maximum Loop Current and Battery Feed Resistance

The maximum loop current (at $R_L = 0$) is determined by the RRF resistor between RFO and RXI. The current limit is accomplished by three internal series diodes (see Figure 27) which clamp the voltage across RRF as the loop resistance decreases, thereby limiting the current at RXI. Since the loop current is $102 \times I_{RXI}$, the loop current is therefore clamped. The graphs of Figures 5 to 7 indicate the maximum loop

current at an ambient temperature of + 25°C, and after the IC has reached thermal equilibrium (approx. 10 minutes).

Although the maximum loop current is primarily a function of the RRF resistor, it is also affected by ambient temperature, and slightly by V_{EE} . The ambient temperature effects are due to the temperature dependence of the diodes' forward voltage drop, causing the maximum loop current to change by $\approx -0.3\%/^{\circ}\text{C}$. Changing V_{EE} affects the maximum current in that the power dissipation is changed, thereby changing the die temperature, which affects the diodes' voltage.

The maximum loop current is affected slightly (< 5%) by the choice of the R_S and R_C resistors, since the sense currents through those resistors add to the current supplied by the transistors.

The battery feed resistance is determined by RRF, and is not adjustable independently of the current limit. Defined as $\Delta V_{TIP}/\Delta I_L$, it is $\approx 400\ \Omega$, and is a valid parameter only on long lines where the current limit is not in effect. On short lines, the feed resistance is high since the loop current is clamped at a near constant level. The AC impedance (Return Loss) however, is not determined nor affected by these DC parameters. Return loss is discussed in another section.

If the application requires that the current limit value have a low temperature dependence, refer to the section following this design sequence which describes an alternate configuration.

2) Main Protection Resistors (RP) and Transient Currents

The purpose of the protection resistors (R_P), along with the 4 clamp diodes shown in Figure 4, is to absorb the bulk of the transient energy when transient voltages come in from the phone line. The resistor value must be selected to limit the transient current to a value which can be tolerated by the diodes, while dissipating the energy. The recommended value shown (100 Ω) will limit the current from a 1500 V transient to 15 A, which can be carried by 1N4002 diodes under surge conditions. The resistors must be of a type which can tolerate the high instantaneous energy associated with transients. Resistor manufacturers should be consulted for this information.

Referring to Figure 4, a positive transient on either Tip or Ring, or both, will cause the transient current to be delivered to Ground. A negative transient will cause the transient current to come from the V_{EE} supply line. Therefore, the PC board track supplying V_{CC} and V_{EE} to the MC33121 must be designed to carry the transient currents as well as the normal operating currents. Additionally, since a negative transient will cause a current flow **out** of the power supply's negative output, which is opposite to the normal flow of current, provisions must be made for this reverse current flow. One suggested method is to place a zener transient suppressor (1N6287 for - 42 V, 1N6282 for - 28 V and - 24 V) across the battery supply pins (V_{CC} to V_{EE}) physically adjacent to the MC33121. The inductance associated with PC board tracks and wiring will result in insufficient protection for the MC33121 if the suppressor is located at the opposite end of the line card, or at the power supplies.

Transient currents can be reduced by increasing the value of R_P , with an upper limit determined by the DC conditions on the longest line (highest loop resistance) and minimum V_{EE} supply voltage. These conditions determine the minimum DC

voltage across the transistors, which must be sufficient to handle the largest AC (transmit and receive) signals. If too large a value is selected for R_P , the AC signals will be clipped. It is recommended that each transistor have no less than one volt (DC) across their collector to emitter. System AC specifications may require more than this.

Since the R_P resistors are within the loop, their tolerance can be $\pm 5\%$ with no substantial degradation of longitudinal balance. A $\pm 10\%$ tolerance (20% mismatch) will degrade balance by $\approx 4.0\ \text{dB}$ on a 65 dB device.

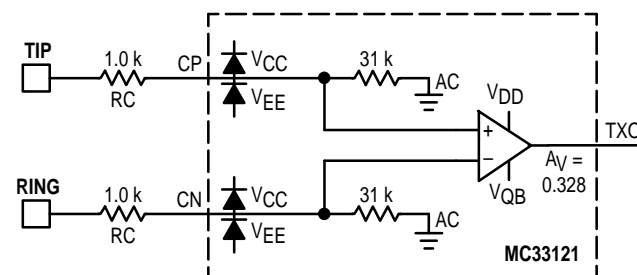

Figure 32. RC Protection Resistors

3) Selecting the RC Resistors

The primary purpose of the R_C resistors is to protect the CP and CN pins from transient voltages and destructive currents. Internally, these pins have clamp diodes to V_{CC} and V_{EE} rated for a maximum of 1.0 A under surge conditions only (Figure 32). The 1.0 k Ω resistors shown in the figures, for example, will provide protection against surges up to 1.0 kV. Resistor manufacturers must be consulted for the proper type of resistor for this environment.

The R_C resistors are in series with internal 31 k Ω resistors, and therefore form a voltage divider to the inputs of the transmit amplifier, as shown in Figure 32. This will affect the transmit gain, receive gain, return loss, and transhybrid rejection (described in subsequent sections). The tolerance of the R_C resistors depends on the value selected for them, since any mismatch between them will create a differential voltage at CP and CN when longitudinal voltages are present on Tip and Ring. To ensure a minimum of 58 dB of longitudinal balance, the resistors' absolute value must not differ by more than 39 Ω . With a nominal value of 1.0 k Ω , their tolerance must be $\pm 2\%$, or less. If their nominal value is 390 Ω or less, their tolerance can be $\pm 5\%$.

4) Longitudinal Impedance (Z_{Long}) — Selecting the R_S Resistors

The longitudinal impedance is determined by the R_S resistors at the TSI and RSI pins according to the following equation:

$$Z_{Long} = \frac{R_S + 100}{51} \quad (4)$$

Z_{Long} is defined as V_{Long}/I_{Long} as shown in Figure 33; for $R_S = 9.1\ \text{k}\Omega$, $Z_{Long} = 180\ \Omega$. The calculated value of Z_{Long} includes the fact that the R_S resistors are in parallel with the synthesized impedance. The tolerance of the R_S resistors therefore depends on how much mismatch can be tolerated between the longitudinal impedances at Tip and at Ring. Calculations indicate the two R_S resistors can have a $\pm 5\%$ tolerance, and still comfortably provide a minimum of 58 dB longitudinal balance.

The resistors must be able to withstand transient voltages expected at Tip and Ring. The TSI and RSI pins have internal clamp diodes rated for a maximum of 1.0 A under surge conditions only (Figure 33). Resistor manufacturers must be consulted for the proper type of resistor for this environment.

5) AC Terminating Impedance and Source Impedance (Z_{ac}) — Return Loss

The return loss measurement is a measure of how closely the AC impedance of the SLIC circuit matches the characteristic impedance of the phone line, or a reference imped-

ance. The reference impedance can be, in some cases, a pure resistance (commonly 600 Ω or 900 Ω), a series resistor and capacitor (900 Ω + 2.16 μF), or a more complex network. To achieve proper return loss with the MC33121, the RRO impedance shown in Figure 34 is to have the same configuration as the reference impedance, but with values scaled according to the equations mentioned below.

CRO, used primarily for DC blocking, is generally a large value (1.0 μF) so as to not affect the impedance of RRO. However, it can be included in the RRO network if a complex network is required.

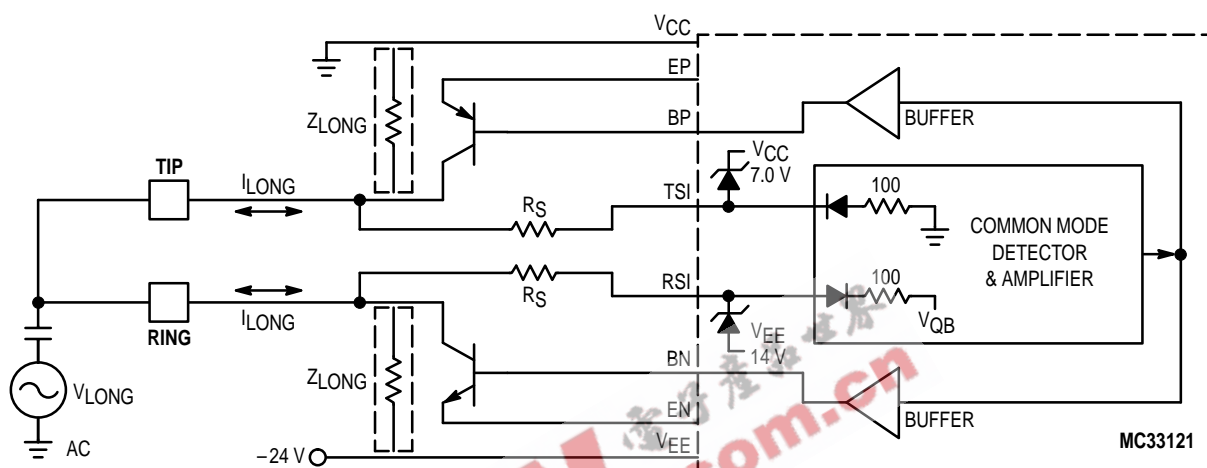

Figure 33. Longitudinal Impedance

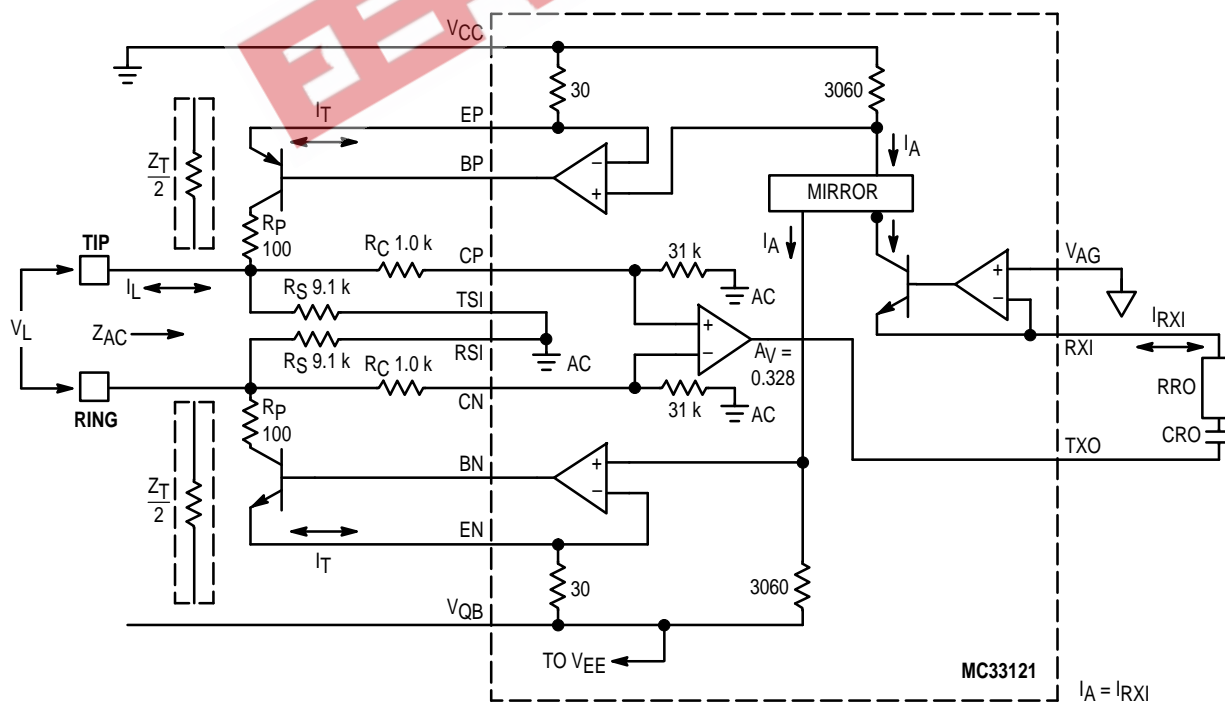

Figure 34. AC Terminating Impedance

Z_{ac} is the impedance looking into the circuit from Tip and Ring (set by RRO), and is defined as V_L/I_L . Half of Z_{ac} is from Tip to V_{CC} , and the other half is from Ring to V_{QB} (an AC ground). Each half is made up of a synthesized impedance ($Z_T/2$) in parallel with R_S and $(RC + 31 k)$. Therefore, Z_{ac} is equal to:

$$Z_{ac} = [Z_T/2 // R_S // (RC + 31 k)] \cdot 2 \quad (5)$$

and
$$\frac{Z_T}{2} = \frac{\{R_S // (RC + 31 k)\} \cdot (Z_{ac}/2)}{\{R_S // (RC + 31 k)\} - (Z_{ac}/2)} \quad (6)$$

The synthesized impedance Z_T is created as follows:

An incoming signal V_L produces a differential voltage at CP and CN, and therefore at TXO equal to:

$$V_{TXO} = \frac{V_L \cdot 31 k \cdot 0.328}{(RC + 31 k)} \quad (7)$$

The signal at TXO creates an AC current I_{RXI} through RRO. RXI is a virtual ground, and CRO is insignificant for first order calculations.

I_{RXI} is gained up by a factor of 102 to produce the current I_T through the transistors.

Z_T is therefore V_L/I_T . The relationship between Z_T and RRO is:

$$RRO = \frac{Z_T \cdot 1.037 \cdot 10^6}{(31 k + RC)} \quad (8)$$

While equation 8 gives the exact value for RRO, a first order approximation is $Z_{ac} \cdot 33.5$.

a) Resistive Loads (with $RC = 1.0 k$, $R_S = 9.1 k$):

For a 600Ω resistive system, Z_T calculates to 626Ω , and RRO calculates to $20.3 k\Omega$.

For a 900Ω resistive system, Z_T calculates to 961Ω , and RRO calculates to $31.14 k\Omega$.

b) Complex Loads

For complex (nonresistive) loads, the MC33121 must be made to look like a termination impedance equal to that complex load. This is accomplished by configuring RRO the same as the complex load, but with all impedance values increased according to the scaling factor of Equation 9.

$$SF = \frac{[(RC + 31 k) // R_S] \cdot 1.037 \cdot 10^6}{(RC + 31 k) \cdot [(RC + 31 k) // R_S - (Z_{ac}/2)]} \quad (9)$$

Z_{ac} is computed at a nominal frequency of interest. A first order approximation of Equation 9 is:

$$SF = 1.037 \cdot 10^6 / (RC + 31 k) \quad (9a)$$

For example:

IF THE AC LOAD IS:

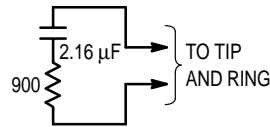

THEN RRO SHOULD BE:

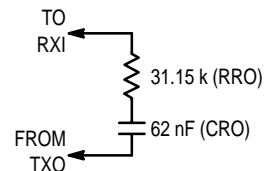

IF THE AC LOAD IS:

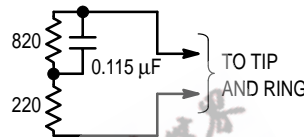

THEN RRO SHOULD BE:

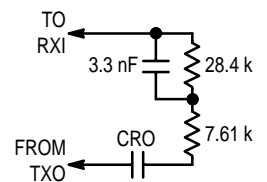

CRO must remain in series with the network to provide DC blocking. If the load network does not include a series capacitor (as in the second example above), CRO should be large ($1.0 \mu F$) so its impedance does not affect the RRO network. The above procedure will yield a return loss measurement which is constant with respect to frequency. The RRO resistor, or network, must have a tolerance equal to or better than the required system tolerance for return loss and receive gain.

6) Receive Gain (G_{RX})

The receive gain involves the same circuit as Figure 34, but with the addition of the RRX resistor (or network) which sets the receive gain. See Figure 35.

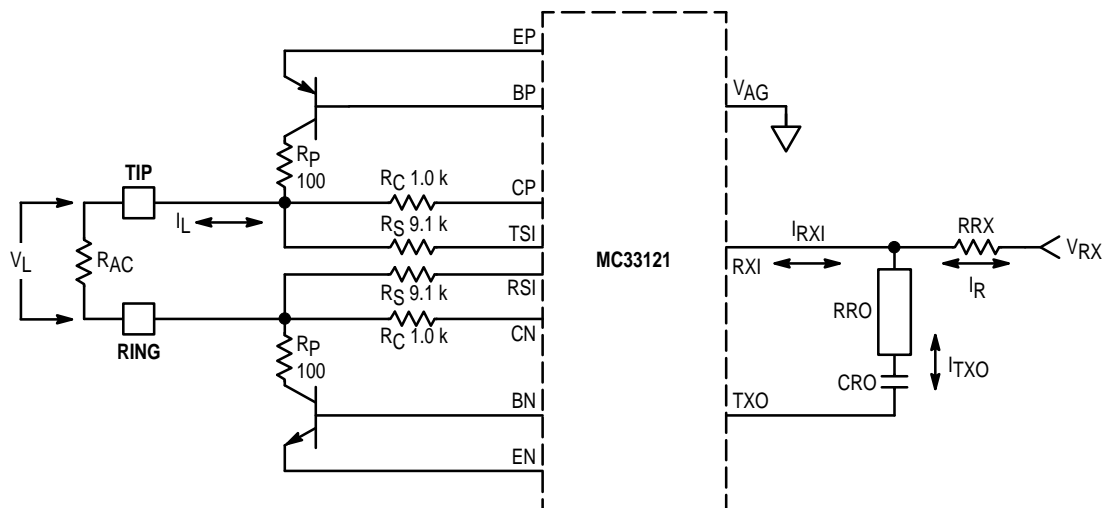

Figure 35. Receive Gain

The receive gain (G_{RX}), defined as the voltage gain from V_{RX} to V_L , is calculated as follows:

R_{X1} is a virtual ground, and R_{ac} is the AC impedance of the load (phone line).

The AC current generated in the transistors is $102 \cdot I_{RX1}$, which is equal to $102 \cdot (I_R - I_{TXO})$.

$I_R = V_{RX}/R_{RX}$, and

$$I_{TXO} = \frac{V_{TXO}}{R_{RO}} = \frac{V_L \cdot 31 \text{ k} \cdot 0.328}{R_{RO} \cdot (31 \text{ k} + RC)} \quad (10)$$

Using equations 5 and 8, involving Z_{ac} , R_S and RC , and the above equations yields:

$$\frac{V_L}{V_{RX}} = G_{RX} = \frac{102 \cdot (R_{ac}/Z_{ac})}{R_{RX}} \quad (11)$$

$$\text{Therefore, } R_{RX} = \frac{102 \cdot (R_{ac}/Z_{ac})}{G_{RX}} \quad (12)$$

Equation 12 applies **only** for the case where R_{ac} and Z_{ac} have the same configuration. If they also have the same magnitude, then set $R_{RX} = 51 \cdot R_{ac}$ to set a receive gain of 0 dB. The AC source impedance of the above circuit to Tip and Ring is Z_{ac} . For the case where $R_{ac} \neq Z_{ac}$, use the following equation:

$$\frac{V_L}{V_{RX}} = \frac{102}{R_{RX} \cdot \left[\frac{1}{Z_L} + \frac{1.037 \cdot 10^6}{(31 \text{ k} + RC) \cdot R_{RO}} \right]} \quad (13)$$

$$\text{where } Z_L = \left[\frac{R_{ac}}{2} // R_S // (RC + 31 \text{ k}) \right] \cdot 2 \quad (14)$$

a) Resistive Loads

For a 600 Ω resistive system, set $R_{RX} = 30.6 \text{ k}\Omega$, and for a 900 Ω resistive system, set $R_{RX} = 45.9 \text{ k}\Omega$.

b) Complex Loads

For complex (nonresistive) loads, the R_{RX} resistor needs to be replaced with a network having the same configuration as the complex load, but with all impedance values scaled up by a factor of 51 (for 0 dB gain). If a gain other than 0 dB is desired, the scaling factor is determined from Equation 12. This method applies **only** if the R_{RO} network has been made complex comparable to the load according to the procedure in the previous section (Equations 5 – 9a), such that $R_{ac} = Z_{ac}$. Using a scaling factor of 51, and the previous examples, yields:

IF THE AC LOAD IS:

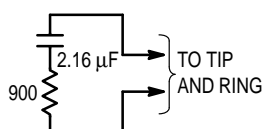

THEN R_{RX} SHOULD BE:

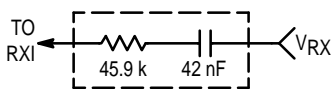

IF THE AC LOAD IS:

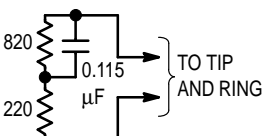

THEN R_{RX} SHOULD BE:

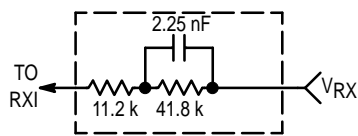

The preceding procedure will yield a receive gain which is constant with respect to frequency. The R_{RX} resistor, or network, must have a tolerance equal to or better than the required system tolerance for receive gain.

7) Transmit Gain (G_{TX})

Setting the transmit gain involves selecting R_{TX1} and R_{TX2} in Figure 28. The voltage gain from V_L to V_{TX} is calculated from the following:

$$G_{TX} = \frac{V_{TX}}{V_L} = \frac{R_{TX2} \cdot 31 \text{ k} \cdot 0.328}{R_{TX1} \cdot (RC + 31 \text{ k})} \quad (15)$$

For 0 dB gain, set $R_{TX2} = 3.15 \times R_{TX1}$ (for $RC = 1.0 \text{ k}$). The actual values of R_{TX2} and R_{TX1} are not critical — only their ratio so as to provide the proper gain at the op amp. Once the ratio is established, the two resistors can be selected from a set of standard resistor values. The minimum value for R_{TX1} is limited by the drive capability of TXO , which is a nominal $\pm 800 \mu\text{A}$ peak ($\pm 275 \mu\text{A}$ minimum). As a general rule, R_{TX1} should be between 5.0 $\text{k}\Omega$ and 20 $\text{k}\Omega$. The load on TXO is the parallel combination of R_{TX1} and R_{RO} .

CTX is for DC blocking, and is typically a large value (1.0 μF) so as to not be a significant impedance. In general, it should **not** be used for low frequency rolloff as that will affect the transhybrid rejection (discussed in the next section). Low frequency rolloff should be done after the op amp. High frequency roll-off can be set by placing a capacitor across R_{TX2} .

For complex loads (at Tip and Ring), if R_{RO} and R_{RX} have been made complex comparable to the load as described in the previous sections, neither R_{TX1} nor R_{TX2} needs to be complex since both the transmit and receive signals which appear at TXO will be flat with respect to frequency.

R_{TX1} and R_{TX2} must have a tolerance equal to or better than the required system tolerance for the transmit gain.

8) Balance Network (RB) — Transhybrid Rejection

When a receive signal is applied to V_{RX} to produce a signal at Tip and Ring, the two-to-four wire arrangement of a hybrid (the MC33121) results in a reflected signal at TXO . Transhybrid rejection involves canceling that reflected signal before it appears at V_{TX} . The method used is to insert the RB resistor (or network) as shown in Figure 36. The current I_B , supplied from V_{RX} , cancels the current I_{TX1} supplied from TXO (Node A is a virtual ground). Good transhybrid cancellation requires that the currents be equal in magnitude **and** 180° out of phase at Node A.

Using the equations for transmit and receive gains, the current I_{TX1} is equal to:

$$I_{TX1} = \frac{33.5 \cdot V_{RX} \cdot Z_{ac} \cdot Z_L \cdot 31 \text{ k}}{R_{RX} \cdot [Z_{ac} + Z_L] \cdot R_{TX1} \cdot (RC + 31 \text{ k})} \quad (16)$$

a) For the case where R_{RO} and R_{RX} are comparable in configuration to Z :

Since $I_B = V_{RX}/R_B$, then R_B can be determined from:

$$R_B = \frac{R_{RX} \cdot R_{TX1} \cdot (RC + 31 \text{ k})}{33.5 \cdot [Z_{ac}/Z_L] \cdot 31 \text{ k}} \quad (17)$$

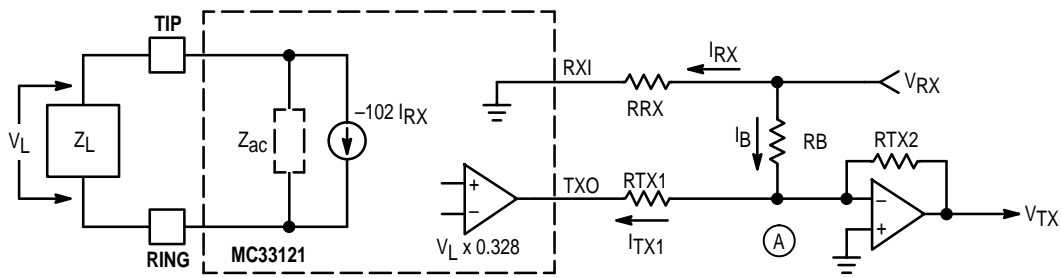

Figure 36. Balance Resistor

Equation 17 provides a value for an RB resistor which will provide the correct magnitude for I_B . The correct phase relationship is provided by the fact that the signal at TXO is out of phase with that at V_{RX} . The phase relationship will be 180° **only** if RRO and RRX are of a configuration identical to that of the load. This applies regardless of whether the load, Z_L , (and RRO and RRX) are purely resistive or of a complex nature. Equation 17 reduces to a non-complex resistance if RRX, Z_{ac} , and Z_L are all comparably complex.

For the case where $Z_{ac} = Z_L$, $RRX = 51 \cdot Z_{ac}$, and $RC = 1.0 \text{ k}$, Equation 17 reduces to:

$$RB = 3.15 \cdot RTX1 \quad (18)$$

b) For the case where Z_{ac} and Z_L do not have the same frequency characteristics:

For the case where, for reasons of cost and/or simplicity, the load (R_L) is considered resistive (whereas in reality it is not a pure resistance) and therefore resistors, rather than networks, were selected for RRO and RRX, using a simple resistor for RB may not provide sufficient transhybrid rejection due to a phase angle difference between V_{RX} and TXO. The terminating impedance may therefore not necessarily be matched exactly to the line impedance, but the resulting circuit still provides sufficiently correct performance for receive gain, transmit gain, and return loss. The rejection can be improved in this case by replacing RB with the configuration shown in Figure 37. Even on a very short phone line there is a reactive component to the load due to the two compensation capacitors (C_C , Figure 4) at the transistor collectors. The two capacitors can be considered in series with each other, and across the load as shown in Figure 37. To simplify the

explanation, the current source and Z_{ac} of Figure 36 are replaced with the Thevenin voltage source and series Z_{ac} . Since Z_L and Z_{ac} are not matched, there will be a phase shift from V_{RX} to the signal across Tip and Ring. This phase shift is also present at TXO. The same phase shift is generated at node B in the RB network by making RB1 equal to Z_{ac} , and Z_L equal to the load. RB2 is then calculated from:

$$RB2 = \frac{RRX \cdot RTX1 \cdot (RC + 31 \text{ k})}{33.5 \cdot Z_{ac} \cdot 31 \text{ k}} \quad (19)$$

For example, for a system where the load is considered a 600Ω resistor ($RRO = 20.3 \text{ k}\Omega$, $RRX = 30.6 \text{ k}\Omega$, $RTX1 = 10 \text{ k}\Omega$, and $RC = 1.0 \text{ k}\Omega$), RB1 would be a 600Ω resistor, Z_L (in the RB network) would be a 600Ω resistor in parallel with a $0.005 \mu\text{F}$ capacitor, and RB2 calculates to $15.715 \text{ k}\Omega$.

The RB resistor, or network, must have a tolerance equal to or better than the required system tolerance for transhybrid rejection.

9) Logic Interface

The logic circuit (output ST1, and the I/O labeled ST2/PDI) is depicted in Figure 30, and functions according to the Status Output Truth Table (Table 1).

a) Output Characteristics

ST1 is a traditional NPN pull-down with a $15 \text{ k}\Omega$ pull-up resistor. Figures 19 and 20 indicate its output characteristics.

ST2 is configured with the following items: a) a 1.0 mA current source for a pull-down which is active only when ST2 is internally set low; b) an $800 \mu\text{A}$ current source pull-up which is active only when ST2 is internally set high; c) a positive

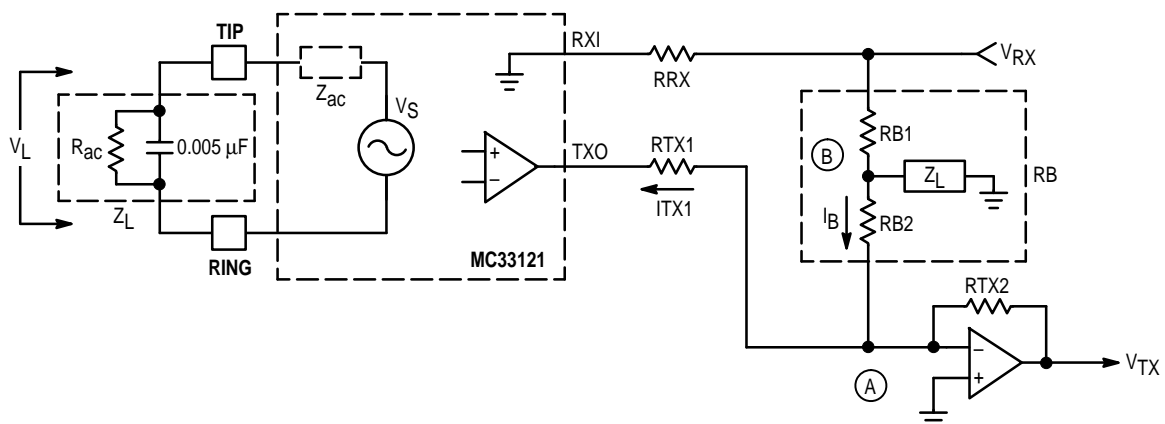

Figure 37. Balance Network

feedback aspect within this output circuit which provides considerable hysteresis for stability reasons. Its output characteristics are shown in Figures 21 and 22. Due to this configuration, any external pull-up resistance which is applied to this pin must be greater than 15 k Ω , or the output may not reliably switch from high to low. Any external pull-down resistance does not affect this output's ability to switch from low-to-high, but does affect the maximum longitudinal currents which can be accepted by the circuit (see the section on Longitudinal Current Capability). The capacitor (C_T) is required to provide a time delay, for stability reasons, during transitions between off-hook and on-hook. This capacitor additionally affects maximum longitudinal currents, as well as stability during pulse dialing (explained below).

b) Hook Status

The MC33121 uses the sense currents at CP and CN to activate the hook status circuit. The sensing is configured such that the circuit monitors the impedance across Tip/Ring, which results in the hookswitch thresholds are minimally affected by the battery voltage. The off-hook to on-hook threshold is affected by the choice of RRF according to the graph of Figure 8, but is not affected by the value of R_S . The on-hook to off-hook threshold is affected by the value of R_S according to the graph of Figure 9, but is not affected by RRF. Varying the RC resistors does not affect the thresholds significantly.

When the telephone is on-hook (ST1 = High, ST2 = Low), the MC33121 is internally powered down, the external transistors are shut off, and power consumption is at a minimum. Upon closure of the phone's hookswitch, ST1 will switch low within 10 μ s. ST2 will then change state slowly due to the external capacitor ($C_T = 5.0 \mu$ F). There is a ≈ 8.0 ms delay for ST2 to reach the threshold necessary to activate the internal bias circuit, which in turn activates the external drive transistors to supply loop current. This delay is necessary to prevent instabilities during the transition to off-hook.

Upon opening the telephone's hookswitch, ST1 will switch high within $\approx 200 \mu$ s. ST2 then requires ≈ 60 ms to reach the threshold to switch off the internal bias circuit, which in turn shuts down the external drive transistors.

c) Pulse Dialing

During pulse dialing, ST1 will change state concurrent with the hookswitch. ST2 is kept from switching during pulse dialing by the external capacitor (C_T), which keeps the MC33121 in a powered up condition and stable. If the C_T capacitor is too small, the voltage at ST2 could drop to the PDI threshold (see section e below) during each pulse. This could cause the MC33121 to create additional noise on the line as it would cycle between a power-up and power-down condition with each dialing pulse.

d) Fault Detection

Faults are defined as excessive leakage from Tip to V_{EE} and/or ground, and from Ring to V_{EE} and/or ground. A single fault is any one of the above conditions, while a double fault is defined as excessive leakage from Tip to V_{EE} and from Ring to V_{CC} , as depicted in Figure 38. Refer to Figures 11 – 15 for the resistance, R_{LK} , which will cause the MC33121 to switch to a power-down condition. If the leakage resistance is less than that indicated in the graphs, the MC33121 will power-down itself and the two external transistors, thereby protecting them from overheating. Both status outputs (ST1 and ST2) will be at a logic low, indicating a fault condition. A fault condition is detected by monitoring an imbalance in the magnitudes of the currents at TSI and RSI, and/or a polarity reversal at Tip and Ring.

The MC33121 will detect the following conditions:

1) When on-hook (see Figure 11):

- a) $< 2.6 \text{ k}\Omega$ between Ring and V_{CC} (depending on R_S and V_{EE}), with no hysteresis at this threshold, or
- b) $< 3.7 \text{ k}\Omega$ between Tip and V_{EE} (depending on R_S and V_{EE}), with no hysteresis at this threshold, or
- c) Both a and b simultaneously.

Leakage from Tip to V_{CC} and/or Ring to V_{EE} are not detected as faults while the MC33121 is on-hook.

2) When off-hook (367 Ω between Tip and Ring):

- a) $< 400 \Omega$ between Tip and V_{CC} ($R_S = 6.2 \text{ k}\Omega$), or
- b) $< 1800 \Omega$ between Tip and V_{EE} , or
- c) $< 400 \Omega$ between Ring and V_{EE} ($R_S = 6.2 \text{ k}\Omega$), or
- d) $< 1800 \Omega$ between Ring and V_{CC} , or
- e) Both b and d simultaneously

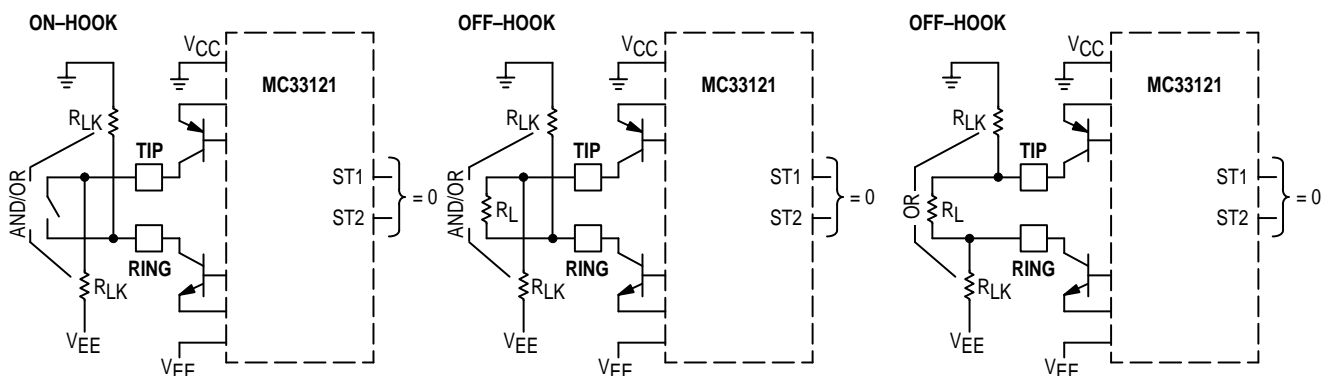

Figure 38. Fault Detection

A simultaneous occurrence of conditions a) and c) is not detected as a fault. See Figures 12 to 15 for the threshold variation with R_L and V_{EE} . Resetting of the fault detection circuit requires that the leakage resistance be increased to a value between 10 k Ω and 20 k Ω , depending on V_{EE} , R_L , and R_S . Both ST1 and ST2 should be monitored for hookswitch status to preclude not detecting a fault condition.

Figure 15 indicates the variation in fault thresholds for Tip-to- V_{CC} and Ring-to-Battery faults, and is valid only for loop resistances of 200 Ω to 800 Ω . On loops larger than 800 Ω , the MC33121 does not reliably indicate the fault condition at ST1 and ST2, but may indicate on-hook status instead. This does not apply to Tip-to-Battery and Ring-to- V_{CC} faults which are correctly detected for lines beyond 800 Ω .

e) PDI Input

The ST2 output can also be used as an input (PDI Input) to power down the circuit, denying loop current to the subscriber (by shutting off the external pass transistors), regardless of the hookswitch position. Powering down is accomplished by pulling PDI to a logic low with an open collector output, or an NPN transistor as shown in Figure 30. The switching threshold is ≈ 1.5 V. The current out of PDI, when pulled low, is ≈ 800 μ A. Releasing PDI allows the MC33121 to resume normal operation.

If the external telephone is off-hook while the MC33121 is powered down, sense currents at CP and TSI will result in some loop current flowing through the loop and back into CN and RSI. This current is generally on the order of 1.0 to 3.0 mA, determined primarily by the R_S resistors, loop resistance, and V_{EE} . ST1 will continue to indicate the telephone's actual hook status while PDI is held low. The on-to-off hook threshold is the same as that during normal operation, but the off-to-on hook threshold is > 250 k Ω .

When powered down with the PDI pin, the receive gain (V_{RXI} to Tip/Ring) is muted by > 90 dB, and the transmit gain (Tip/Ring to TXO) is muted by > 30 dB.

Power Dissipation, Calculation and Considerations

a) Reliability

The maximum power dissipated by the MC33121 must be considered, and managed, so as to not exceed the junction temperature listed in the Maximum Ratings Table. Exceeding this temperature on a recurring basis will reduce long term reliability, and possibly degrade performance. The junction temperature also affects the statistical lifetime of the device, due to long term thermal effects within the package. Today's plastic integrated circuit packages are as reliable as ceramic packages under most environmental conditions. However, when the ultimate in system reliability is required, thermal managements must be considered as a prime system design goal.

Modern plastic package assembly technology utilizes gold wire bonded to aluminum bonding pads throughout the electronics industry. When exposed to high temperatures for protracted periods of time an intermetallic compound can form in the bond area resulting in high impedance contacts and degradation of device performance. Since the formation of intermetallic compounds is directly related to device junction temperature, it is incumbent on the designer to determine that the device junction temperature is consistent with system reliability goals.

Based on the results of almost ten years of + 125°C operating life testing, Table 2 has been derived indicating the relationship between junction temperature and time to 0.1% wire bond failure.

Table 2. Statistical Lifetime

Junction Temperature (°C)	Time (Hours)	Time (Years)
80	1,032,200	117.8
90	419,300	47.9
100	178,700	20.4
110	79,600	9.4
120	37,000	4.2
130	17,800	2.0
140	8,900	1.0

Motorola MECL Device Data, DL122

The "Time" in Table 2 refers to the time the device is operating at that junction temperature. Since the MC33121 is at a low power condition (nominally 40 mW) when on-hook, the duty cycle must be considered. For example, if a statistical duty cycle of 20% off-hook time is used, operation at 130°C junction temperature (when off-hook) would result in a statistical lifetime of ≈ 10 years.

b) Power and Junction Temperature Calculation

The power within the IC is calculated by subtracting the power dissipated in the two-wire side (the transistors and the load) from the power delivered to the IC by the power supplies. Refer to Figure 4 and 27.

$$P_D = |V_{DD} \cdot I_{DD}| + |V_{EE} \cdot I_{EE}| - (I_L \cdot |V_{EP} - V_{EN}|) \quad (20)$$

The terms V_{EP} and V_{EN} are the DC voltages, with respect to ground, at the EP and EN pins. These voltages can be measured, or can be approximated by:

$$V_{EP} \approx - (30 \Omega \cdot I_L)$$

$$V_{EN} \approx |V_{EE}| + 2.1 \text{ V} + (I_L \cdot 35 \Omega)$$

Refer to Figure 23. The junction temperature is then calculated from:

$$T_J = T_A + (P_D \cdot \theta_{JA}) \quad (21)$$

where T_A is the ambient air temperature at the IC package, and θ_{JA} is the junction-to-ambient thermal resistance shown in Figure 39. The highest junction temperature will occur at maximum V_{EE} and V_{DD} , maximum loop current, and maximum ambient temperature.

If the above calculations indicate the junction temperature will exceed the maximum specified, then it is necessary to reduce the maximum loop current, ambient temperature, and/or V_{EE} supply voltage. Air flow should not be restricted near the IC by tall components or other objects since even a small amount of air flow can substantially reduce junction temperature. For example, typically an air flow of 300 LFPM (3.5 mph) can reduce the effective θ_{JA} by 14 to 20% from that which occurs in still air. Additionally, providing as much copper area as possible at the IC pins will assist in drawing away heat from within the IC package. For additional information on this subject, refer to the "Thermal Considerations" section of *Motorola MECL System Design Handbook*, and the "System Design Considerations" section of *Motorola MECL Device Data*.

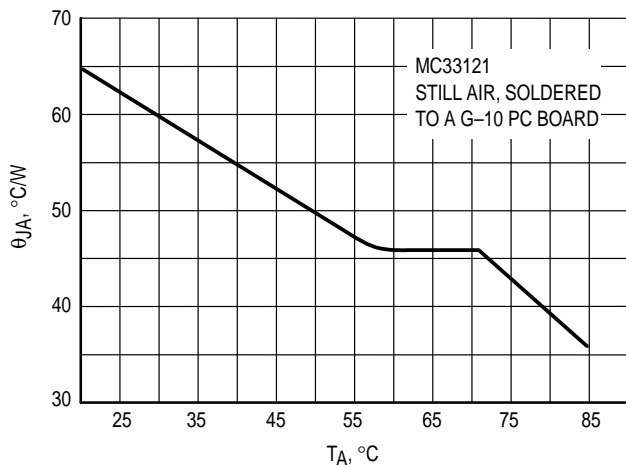

Figure 39. Thermal Resistance (Junction-to-Ambient)

Selecting the Transistors

The specifications for the two loop current pass transistors involve their current gain, voltage rating, and power dissipation capabilities at the highest ambient temperatures. Power dissipation during both normal operation and faults must be considered when determining worst case situations. Generally, more power is dissipated during a fault condition than during normal operation.

The transistors' minimum beta is recommended to be 40 at the loop currents involved in the application. A lower beta could degrade gain and balance performance. Maximum beta should be less than 500 to prevent possible oscillations. Darlington type transistors should not be used. The voltage rating should be consistent with the maximum V_{EE} , expected transients, and the protection scheme used.

Referring to Figure 27, during normal operation the loop current and the voltage across the transistors are both at a maximum when the load impedance (R_L) is at a minimum. The loop current is determined by RRF and the graphs of Figures 5 – 7. The voltage across each transistor is determined from the following:

$$V_T = \frac{|V_{EE}| - 2.1 - [(65 + 2RP + R_L) \cdot I_L]}{2} \quad (22)$$

The power in each transistor is then ($V_T \cdot I_L$). The voltage across the two transistors will always be nearly equal during normal operation, resulting in equal power dissipation. The graph of Figure 24 indicates the power dissipated in each transistor where $RP = 100 \Omega$.

During a fault condition, depicted in Figure 38, if the leakage resistance from Tip to V_{EE} or from Ring to V_{CC} is less than that shown in Figures 12 – 14 (when off-hook), the MC33121 will power down the transistors to protect them from overheating. Should the leakage resistance be slightly higher than that shown in the graphs, however, and the fault detection has not been activated, the power in one transistor (in a single fault, both transistors in a double fault) will be higher than normal. The power will depend on V_{EE} , R_L , RP and the leakage resistance. Table 3 is a guide of the power in the transistor dissipating the higher power level.

The power (in watts) in the two right columns indicates the power dissipated by that transistor if it is carrying the maximum fault current. The system designer should attempt to predict possible fault conditions for the system, and then

measure the conditions on the transistors during the worse case fault(s).

Table 3. Transistor Power During a Fault

V_{EE}	R_L	PNP	PNP
- 42	150	0.835	0.615
- 24	150	0.257	0.176
- 42	600	0.601	0.185
- 24	600	0.109	0.057

For most applications involving a maximum loop current of 30 – 40 mA, and a maximum T_A of + 85°C, and where faults may occur, the MJD243 and MJD253 DPAK transistors are recommended. When mounted as described in their data sheet, they will handle both the normal loop current as well as most fault conditions. If faults are not expected to occur in a particular application, then smaller package transistors, such as MPS6717 and MPS6729, may be used. Each application must be evaluated individually when selecting the transistors.

Other possible transistors which can be considered:

PNP	NPN
MJD253-1	MJD243-1
MJE253	MJE243
MJD32	MJD31
MJD42	MJD41
MJD350	MJD340
TIP30A,B,C	TIP29A,B,C

Longitudinal Current Capability

The maximum longitudinal current which can be handled without distortion is a function of loop current, battery feed resistance, the longitudinal impedance, and the components on ST2.

Since the pass transistors cannot pass current in the reverse direction, the DC loop current provides one upper boundary for the peak longitudinal current plus peak speech signal current. The battery feed resistance determines, in effect, the DC voltage across the transistors, which is a measure of the headroom available for the circuit to handle the peak longitudinal voltage plus peak speech signal voltage. The longitudinal impedance, determined by the R_S resistors (equation 4), determines the longitudinal current for a given longitudinal voltage.

While analysis of the above items may yield one value of maximum longitudinal current, a different limit (which may be higher or lower) is imposed by the capacitor C_T , and any pulldown resistance R_T , on Pin 12 (ST2). This is due to the fact that the sense currents at TSI and RSI will be alternately mismatched as Tip and Ring move up and down together in the presence of longitudinal signals. When the longitudinals are strong, the internal fault detect circuit is activated with each 1/2 cycle, which attempts to switch ST2 low (see the section on Fault Detection). The speed at which ST2 can switch low is a function of both the external capacitor, C_T and any pulldown resistance, R_T .

The graphs of Figures 25 and 26 indicate the maximum longitudinal current which can be handled (in Tip and in Ring) without distortion or causing ST2 to switch low.

PC Board Layout Considerations

PC board considerations include thermal, RFI/EMI, transient conditions, interconnection of the four wire side to the

codec/filter, and others. Wirewrapped boards should be avoided — breadboarding should be done on a (at least) reasonably neat PC board.

a) Thermal

Power dissipated by the MC33121 and the two transistors must be removed to prevent excessively high junction temperatures. The equations for calculating junction temperatures are mentioned elsewhere in this data sheet. Heat is removed by both air flow and copper foil on the PC board. Since even a small amount of air flow substantially reduces junction temperatures compared to still air, tall components or other objects should not be placed such that they block air flow across the heat generating devices. Increasing, wherever possible, the area of the copper foil at the IC pins will provide additional heat removal capability. A ground plane can generally help here, while at the same time helping to reduce RFI problems.

b) RFI/EMI

While the MC33121 is intended for use at audio frequencies, the internal amplifiers have bandwidths in excess of 1.0 MHz, and can therefore respond to externally induced RFI and EMI. Interference signals can come in on the phone line, or be radiated on to the PC board from nearby radio stations or from high frequency circuitry (digital & microprocessor circuitry) in the vicinity of the line card.

Usually RFI entering from the phone line at Tip and Ring can be removed by the compensation capacitors (C_C) provided they are connected to a good quality RF ground (generally the same ground which connects to V_{CC} on the MC33121). The ground track should be as wide and as direct as possible to minimize lead inductance. Generally better results can be obtained if an RF bleedoff to earth (or chassis)

ground can be provided where the twisted pair phone line comes into the system.

To minimize problems due to noise radiating directly onto the PC board from nearby high frequency circuitry, all components associated with the MC33121 should be physically as close as possible to the IC. The most sensitive pins in this respect are the CP, CN, RSI, TSI, VAG and RXI pins. Keeping the tracks short minimizes their "antenna" effect.

c) Transient Conditions

When transient voltages come in to Tip and Ring, the transient currents, which can be several amperes, must be carried by the ground line (V_{CC}) an/or the V_{EE} line. These tracks, along with the protection and clamping devices, must be designed for these currents at the frequencies involved. If the tracks are narrow, not only may they be destroyed by the high currents, but their inductance can allow the voltage at the IC, and other nearby components, to rise to damaging levels.

The protection circuits shown in Figure 4, and in other figures in this data sheet, are such that the bulk of the transient energy is dissipated by external components (the protection resistors and the clamp diodes). The MC33121 has internal diodes to limit voltage excursions on the pins, and to pass a small amount of the transient current — typically less than 1.0 A peak. The arrangement of the diodes is shown in Figure 40.

d) Interconnection of the four-wire side

The connections on the four-wire side to the codec and other digital circuitry involves keeping digital noise out of the speech paths, and also ensuring that potentially destructive transients on Tip and Ring do not get through to the + 5.0 V system.

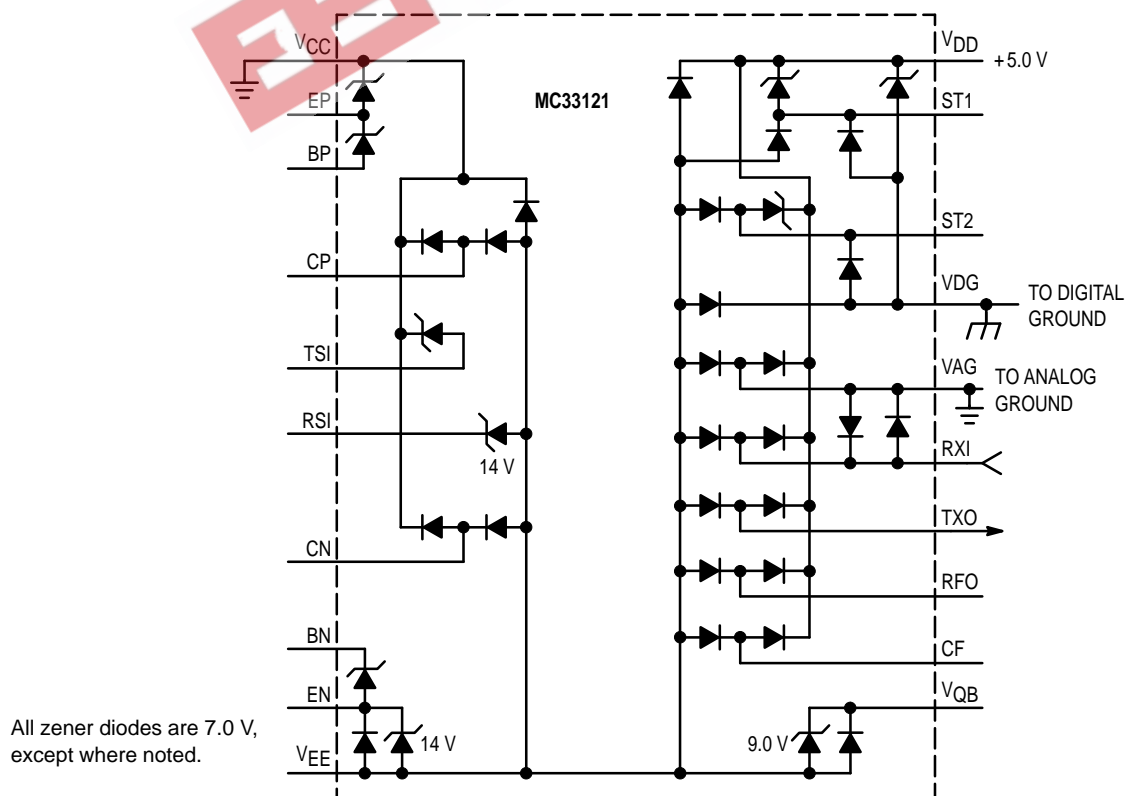

Figure 40. Protection Diodes

Basically, digital connections to ST1 and ST2 should be referenced to the V_{DD} and V_{DG} pins, while the transmit and receive analog signals should be referenced to the analog ground (V_{AG}). V_{CC} should be connected to a clean battery ground, and generally should not be connected directly to V_{DG} and/or V_{AG} (on the line card) when strong transients are anticipated. Even with a good layout, V_{CC} can move several volts when a transient hits, possibly damaging components on the +5.0 V line if their grounds have a direct connection at the line card. The MC33121 is designed to allow V_{CC} to move as much as ± 30 V with respect to V_{DG} and V_{AG} on a transient basis only. V_{CC} and the other grounds should preferably be connected together at the power supply rather than at the IC. Internally, the MC33121 has clamp diodes on the 4-wire side pins as indicated in Figure 40.

If the codec has a single ground pin, as in Figure 41, it will be the reference for both the digital and analog signals, and must be connected to both V_{AG} and V_{DG} on the MC33121. If the codec has separate digital and analog grounds, as in Figure 42 (the MC145503 internally generates the analog ground), then each ground should be connected to the

appropriate ground on the MC33121.

e) Other

A 0.1 μF capacitor should be provided across V_{CC} to V_{EE} on the MC33121 to help keep idle channel noise to a minimum.

The C_{QB} capacitor (on the V_{QB} pin) forms a pole with an internal 7.5 k Ω resistor to filter noise from the V_{EE} pin, providing an internal quiet battery supply for the speech amplifiers. Power supply rejection will depend on the value and quality of this capacitor at the frequencies of concern. Tantalum capacitors generally have better high frequency characteristics than electrolytics. See Figure 17 and 18 for ripple rejection characteristics (the four-wire data was measured at pin 11 (TXO)). Figure 16 indicates ripple rejection from the +5.0 V supply (V_{DD}).

In general, pc board tracks carrying analog signals (on the four-wire side and Tip/Ring) should not be routed through the digital section where they could pick up digital noise. Any tracks longer than a few inches should be considered an antenna and should be checked for potential noise or RFI pick-up which could affect the circuit operation.

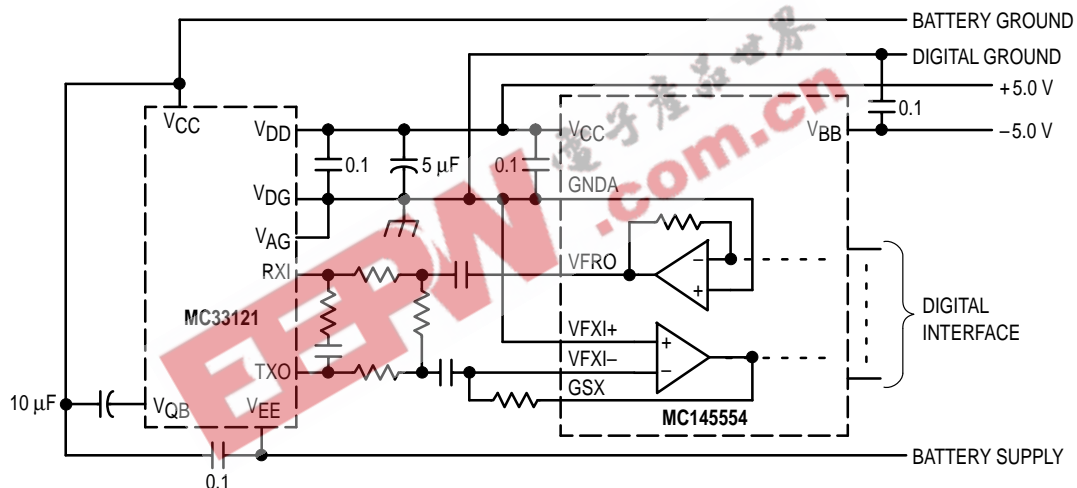

Figure 41. Connection to a CODEC With a Single Ground

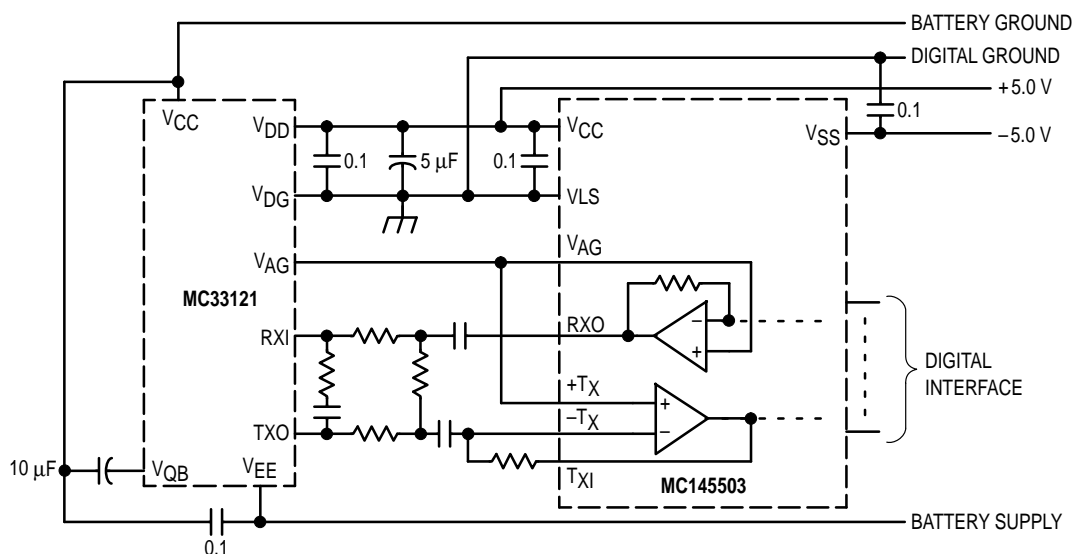

Figure 42. Connection to a CODEC With Separate Grounds

Alternate Circuit Configurations

a) Loop Current Limit

Replacing the RRF resistor with the circuit in Figure 43 will change the DC loop current characteristics in two ways from the graphs of Figures 5 – 7; a) the maximum loop current on a short line can be reduced while increasing the current on a long line, and b) the temperature dependence of the maximum current is reduced to the TC of the external reference diode.

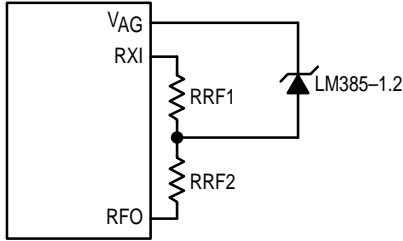

Figure 43. Alternate Current Limit Circuit

The LM385-1.2 is a precision temperature stable zener diode. As the load impedance at Tip and Ring is reduced, the voltage at RFO goes increasingly negative. When the zener diode is turned on, the current into RXI is then clamped at a value determined by RRF1 and the zener diode. To calculate the two resistors, use the following procedure:

RRF1 must be $> 0.7 \cdot (RRF1 + RRF2)$;

Determine RRF1 to set the current limit on a short line by using the following equation:

$$RRF1 = \frac{102 \cdot 1.23 \text{ V}}{I_{L(\max)} - 3.0 \text{ mA}} \quad (23)$$

Then using Equation 1 calculate RRF for the long line current. RRF2 is then determined by:

$$RRF2 = RRF - RRF1 \quad (24)$$

Figure 44 illustrates one example using the above circuit. Comparing this graph to the 5100 Ω curve of Figure 7 shows a substantial decrease in the current limit (at $R_L = 0$), resulting in reduced power consumption and dissipation. Use of this circuit does not affect the hookswitch or fault thresholds.

b) Protection Scheme

The protection circuit shown in Figure 45 has the advantage of drawing $\approx 90\%$ of the transient current from ground (V_{CC}) on a negative transient, rather than from the V_{EE} line as the circuit of Figure 4 does. The majority of the transient current flows through the RP resistors and the Mosorbs while

a small amount ($\approx 10\%$) flows through the sense resistors and the CP, CN, RSI pins. On a positive transient, all the current is directed to ground. The diode in the NPN's collector prevents reverse current through the base-collector junction of the transistor during a negative transient.

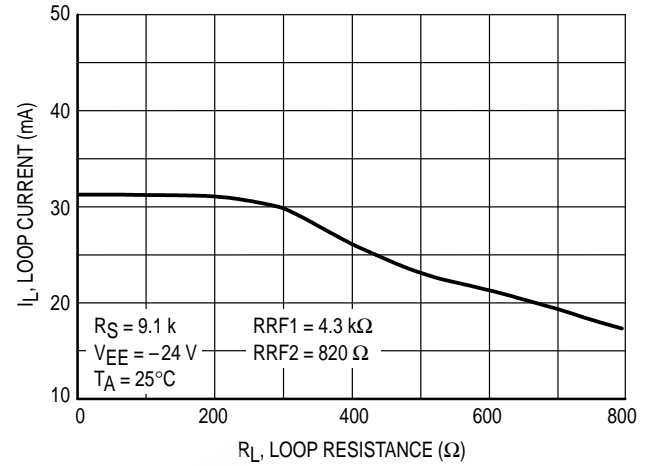
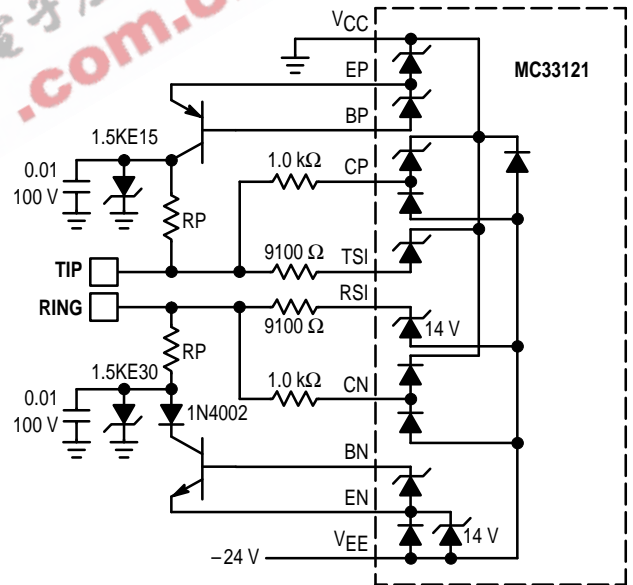

Figure 44. Loop Current versus Loop Resistance Alternate Loop Current Limit Configuration



All zener diodes are 7.0 V except as noted.

Figure 45. Alternate Protection Scheme

CIRCUIT PERFORMANCE

The following three circuits are presented as typical application examples, and the accompanying graphs indicate their measured performance. The first circuit (Figure 46) has a 600 Ω pure resistance as the AC load. The second circuit (Figures 47) has as an AC load a 900 Ω resistor in series with a 2.16 μF capacitor. The third circuit (Figure 48) has as an

AC load, a complex network composed of an 820 Ω resistor in parallel with 0.115 μF , and those in series with a 220 Ω resistor. In the graphs of Figures 49 – 51, R_L = Return Loss, THR = Transhybrid Rejection, GTX = Transmit Gain, GRX = Receive Gain.

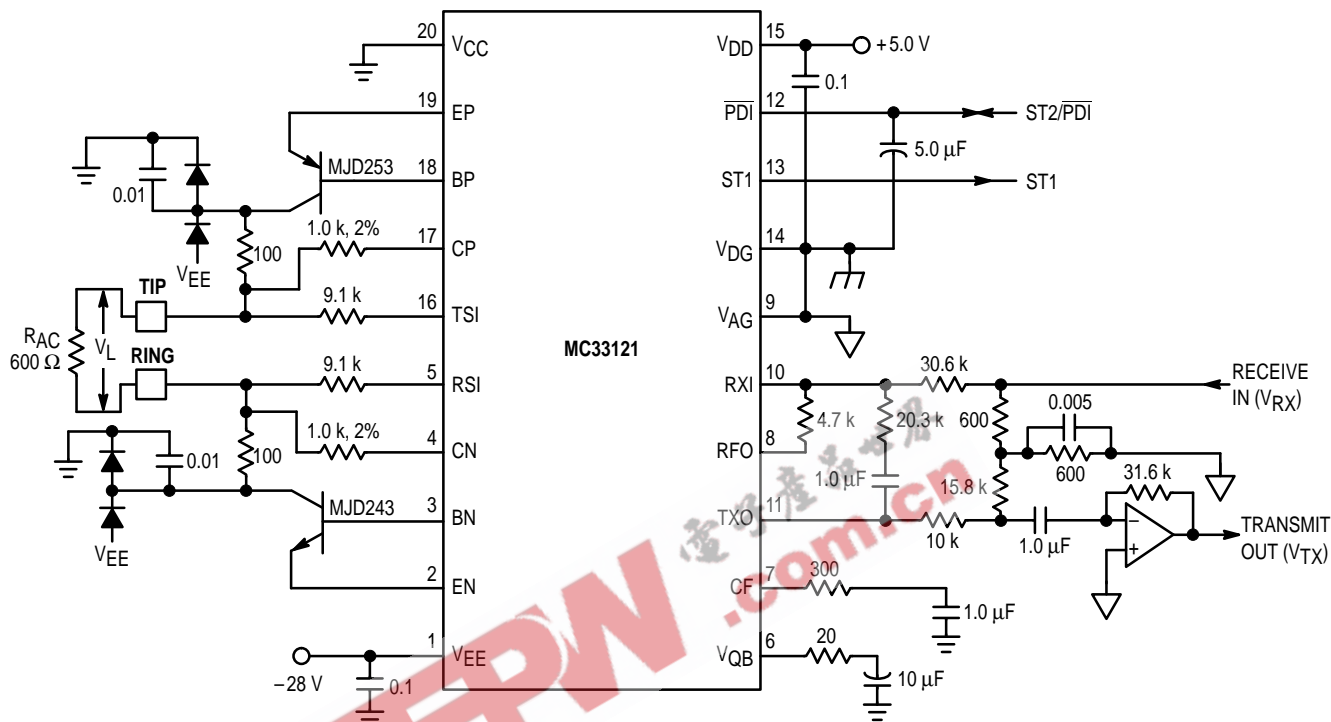

Figure 46. 600 Ω System

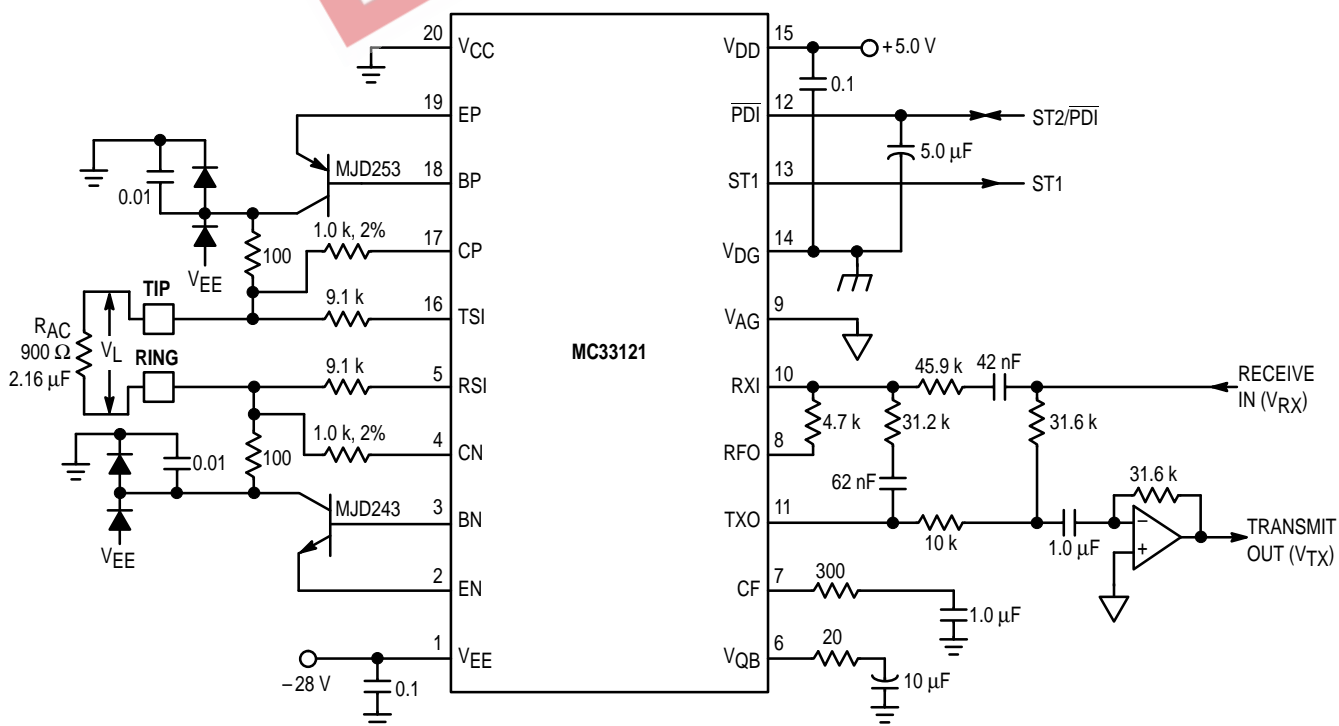

Figure 47. 900 Ω and 2.16 μF System

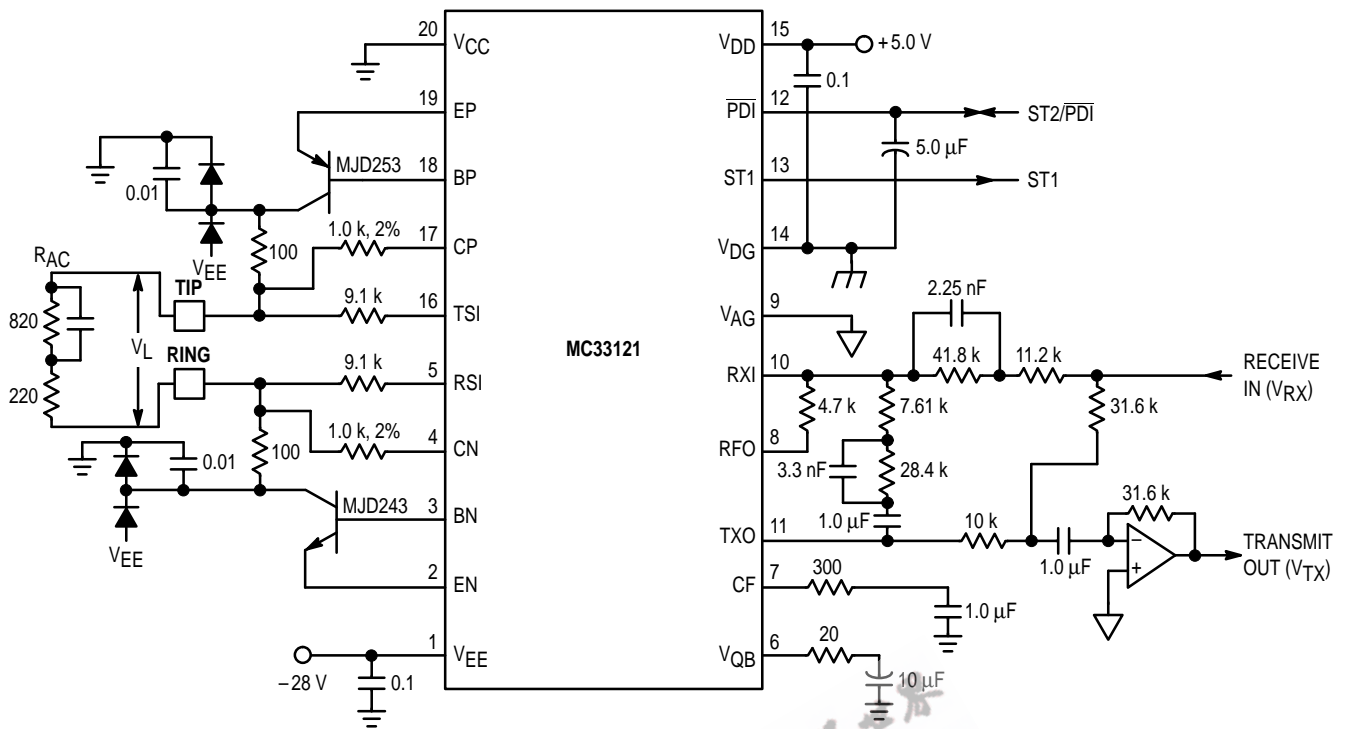

Figure 48. 220 Ω and 820 Ω //0.115 μ F System

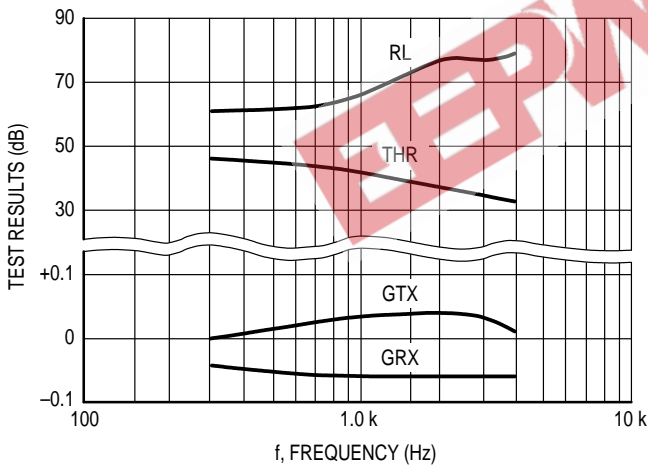

Figure 49. Circuit Performance, 600 Ω System

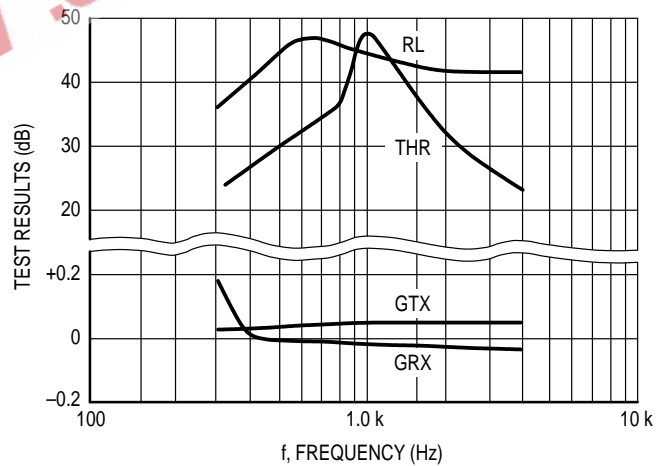
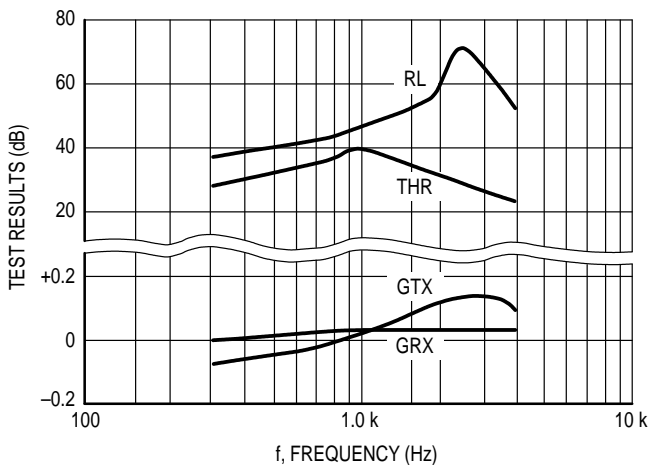
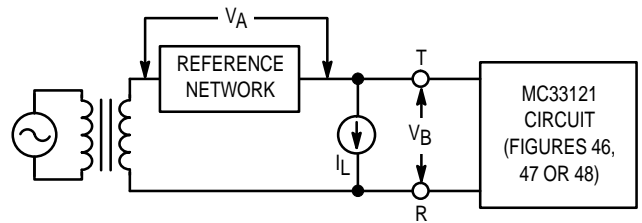

Figure 50. Circuit Performance 900 Ω and 2.16 μ F System



**Figure 51. Circuit Performance
820 Ω/0.115 μF and 220 Ω System**



Reference Network = R_{AC} of Figures 46 to 48.

$$\text{Return Loss} = 20 \log \frac{V_A + V_B}{V_A - V_B}$$

**Figure 52. Return Loss Test Circuit
for Figures 46 to 51**

GLOSSARY

ATTENUATION — A decrease in magnitude of a communication signal, usually expressed in dB.

BALANCE NETWORK — That part of the SLIC circuit which provides transhybrid rejection.

BANDWIDTH — The range of information carrying frequencies of a communication system.

BATTERY — The voltage which provides the loop current, and in some cases powers the SLIC circuit. The name derives from the fact that COs have always used batteries, in conjunction with AC power, to provide this voltage.

BATTERY FEED RESISTANCE — The equivalent Thevenin DC resistance of the SLIC circuit for supplying loop current. Traditionally it is 400 Ω.

C-MESSAGE FILTER — A frequency weighting which evaluates the effects of noise on a typical subscriber's system.

CENTRAL OFFICE — Abbreviated CO, it is a main telephone office, usually within a few miles of its subscribers, that houses switching gear for interconnection within its exchange area, and to the rest of the telephone system. A typical CO can handle up to 10,000 subscriber numbers.

CODEC — Coder/Decoder — Interfacing between the SLIC and the digital switch, it converts the SLIC's transmit signal to digital, and converts the digital receive signal to analog.

dB — A power or voltage measurement unit, referred to another power or voltage. It is generally computed as:

$$10 \cdot \log (P_1/P_2) \text{ for power measurements, and} \\ 20 \cdot \log (V_1/V_2) \text{ for voltage measurements.}$$

dBm — An indication of signal power. 1.0 mW across 600 Ω, or 0.775 V_{rms}, is defined as 0 dBm. Any other voltage level

is converted to dBm by:

$$\text{dBm} = 20 \cdot \log (V_{\text{rms}}/0.775), \text{ or} \\ \text{dBm} = [20 \cdot \log (V_{\text{rms}})] + 2.22.$$

dBmp — Indicates dBm measurement using a psophometric weighting filter.

dB_{rn} — Indicates a dBm measurement relative to 1.0 pW power level into 600 Ω. Generally used for noise measurements, 0 dB_{rn} = -90 dBm.

dB_{rnC} — Indicates a dB_{rn} measurement using a C-message weighting filter.

DTMF — Dual Tone Multifrequency. It is the "tone dialing" system based on outputting two non-harmonic related frequencies simultaneously to identify the number dialed. Eight frequencies have been assigned to the four rows and four columns of a keypad.

FAULT — An incorrect condition where Tip is accidentally connected to the battery voltage, or Ring is connected to ground, or both. The most common fault is Ring to ground.

FOUR WIRE CIRCUIT — The portion of a telephone, or central office, which operates on two pairs of wires. One pair is for the transmit path, and one pair is for the receive path.

FULL DUPLEX — A transmission system which permits communication in both directions simultaneously. The standard handset telephone system is full duplex.

GAIN — The change in signal amplitude (increase or decrease) after passing through an amplifier, or other circuit stage. Usually expressed in dB, an increase is a positive number, and a decrease is a negative number.

HALF DUPLEX — A transmission system which permits communication in one direction at a time. CB radios, with “push-to-talk” switches, and voice activated speaker-phones, are half duplex.

HOOKSWITCH — A switch, within the telephone, which connects the telephone circuit to the subscriber loop. The name derives from old telephones where the switch was activated by lifting the receiver off and onto a hook on the side of the phone.

HYBRID — Another name for a two-to-four wire converter.

IDLE CHANNEL NOISE — Residual background noise when transmit and receive signals are absent.

LINE CARD — The PC board and circuitry in the CO or PBX which connects to the subscriber’s phone line. A line card may hold circuitry for one subscriber, or a number of subscribers.

LONGITUDINAL BALANCE — The ability of the SLIC to reject longitudinal signals on Tip and Ring.

LONGITUDINAL SIGNALS — Common mode signals.

LOOP — The loop formed by the two subscriber wires (Tip and Ring) connected to the telephone at one end, and the central office (or PBX) at the other end. Generally, it is a floating system not referred to ground, or AC power.

LOOP CURRENT — The DC current which flows through the subscriber loop. It is typically provided by the central office or PBX, and ranges from 20 to 120 mA.

OFF-HOOK — The condition when the telephone is connected to the phone system, permitting the loop current to flow. The central office detects the DC current as an indication that the phone is busy.

ON-HOOK — The condition when the telephone is disconnected from the phone system, and no DC loop current flows. The central office regards an on-hook phone as available for ringing.

PABX — Private Automatic Branch Exchange. In effect, a miniature central office, it is a customer owned switching system servicing the phones within a facility, such as an office building. A portion of the PABX connects to the Bell (or other local) telephone system.

PROTECTION, PRIMARY — Usually consisting of carbon blocks or gas discharge tubes, it absorbs the bulk of a lightning induced transient by clamping the voltages to less than ± 1500 V.

PROTECTION, SECONDARY — Usually located on the line card, it protects the SLIC and associated circuits from transient surges. Typically, it must be capable of clamping a ± 1.5 kV surge of 1.0 ms duration.

PULSE DIALING — A dialing system whereby the loop current is interrupted a number of times in quick succession. The number of interruptions corresponds to the number dialed, and the interruption rate is typically 10 per second. The old rotary phones, and many new pushbutton phones, use pulse dialing.

RECEIVE PATH — Within the CO or PBX it is the speech path from the internal switching system towards the phone line (Tip & Ring).

REN — Ringer Equivalence Number. An indication of the impedance or loading factor of a telephone bell or ringer circuit. An REN of 1.0 equals ≈ 8.0 k Ω . The Bell system typically permits a maximum of 5.0 REN (1.6 k Ω) on an individual subscriber line. A minimum REN of 0.2 (40 k Ω) is required by the Bell system.

RETURN LOSS — Expressed in dB, it is a measure of how well the SLIC’s AC impedance matches the line’s AC characteristic impedance. With a perfect match, there is no reflected signal, and therefore infinite return loss. It is calculated from:

$$RL = 20 \cdot \log \frac{(Z_{Line} + Z_{CKT})}{(Z_{Line} - Z_{CKT})}$$

RING — One of the two wires connecting the central office to a telephone. The name derives from the ring portion of the plugs used by operators (in older equipment) to make the connection. Ring is traditionally negative with respect to Tip.

SLIC — Subscriber Line Interface Circuit. It is the circuitry within the CO or PBX which connects to the user’s phone line.

SUBSCRIBER — The customer at the telephone end of the line.

SUBSCRIBER LINE — The system consisting of the user’s telephone, the interconnecting wires, and the central office equipment dedicated to that subscriber (also referred to as a loop).

TIP — One of the two wires connecting the central office to a telephone. The name derives from the tip of the plugs used by operators (in older equipment) to make the connection. Tip is traditionally positive with respect to Ring.

TRANSHYBRID REJECTION — The rejection (in dB) of the reflected signal in the transmit path resulting from a receive signal applied to the SLIC.

TRANSMIT PATH — Within the CO or PBX it is the speech path from the phone line (Tip & Ring) towards the internal switching system.

TWO WIRE CIRCUIT — Refers to the two wires connecting the central office to the subscriber’s telephone. Commonly referred to as Tip and Ring, the two wires carry both transmit and receive signals in a differential manner.

TWO-TO-FOUR WIRE CONVERTER — A circuit which has four wires (on one side) — two (signal & ground) for the outgoing signal, and two for the incoming signal. The outgoing signal is sent out differentially on the two wire side (the other side), and incoming differential signals received on the two wire side are directed to the four wire side. Additional circuit within cancels the reflected outgoing signal to keep it separate from the incoming signal.

VOICEBAND — That portion of the audio frequency range used for transmission across the telephone system. Typically, it is 300 to 3400 Hz.

PACKAGE DIMENSIONS

P SUFFIX PLASTIC PACKAGE CASE 738-03

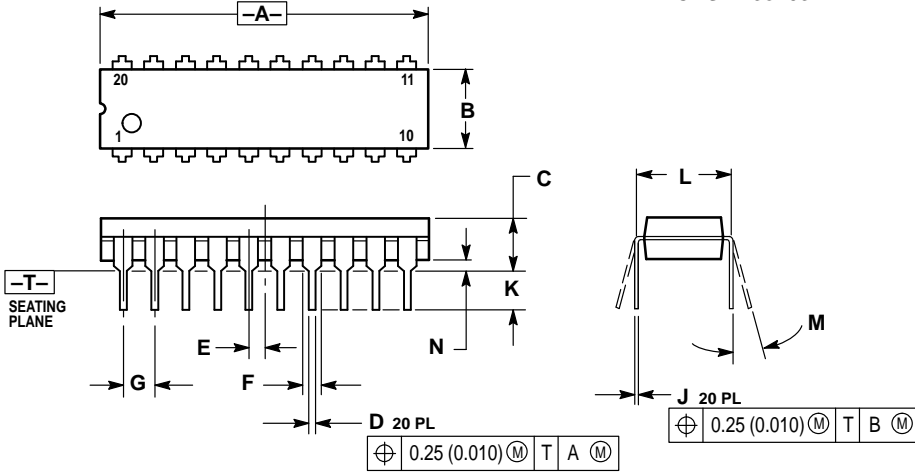

NOTES:

1. DIMENSIONING AND TOLERANCING PER ANSI Y14.5M, 1982.
2. CONTROLLING DIMENSION: INCH.
3. DIMENSION L TO CENTER OF LEAD WHEN FORMED PARALLEL.
4. DIMENSION B DOES NOT INCLUDE MOLD FLASH.

DIM	INCHES		MILLIMETERS	
	MIN	MAX	MIN	MAX
A	1.010	1.070	25.66	27.17
B	0.240	0.260	6.10	6.60
C	0.150	0.180	3.81	4.57
D	0.015	0.022	0.39	0.55
E	0.050 BSC		1.27 BSC	
F	0.050	0.070	1.27	1.77
G	0.100 BSC		2.54 BSC	
J	0.008	0.015	0.21	0.38
K	0.110	0.140	2.80	3.55
L	0.300 BSC		7.62 BSC	
M	0°	15°	0°	15°
N	0.020	0.040	0.51	1.01



Motorola reserves the right to make changes without further notice to any products herein. Motorola makes no warranty, representation or guarantee regarding the suitability of its products for any particular purpose, nor does Motorola assume any liability arising out of the application or use of any product or circuit, and specifically disclaims any and all liability, including without limitation consequential or incidental damages. "Typical" parameters can and do vary in different applications. All operating parameters, including "Typicals" must be validated for each customer application by customer's technical experts. Motorola does not convey any license under its patent rights nor the rights of others. Motorola products are not designed, intended, or authorized for use as components in systems intended for surgical implant into the body, or other applications intended to support or sustain life, or for any other application in which the failure of the Motorola product could create a situation where personal injury or death may occur. Should Buyer purchase or use Motorola products for any such unintended or unauthorized application, Buyer shall indemnify and hold Motorola and its officers, employees, subsidiaries, affiliates, and distributors harmless against all claims, costs, damages, and expenses, and reasonable attorney fees arising out of, directly or indirectly, any claim of personal injury or death associated with such unintended or unauthorized use, even if such claim alleges that Motorola was negligent regarding the design or manufacture of the part. Motorola and are registered trademarks of Motorola, Inc. Motorola, Inc. is an Equal Opportunity/Affirmative Action Employer.

FN SUFFIX
PLCC
CASE 776-02

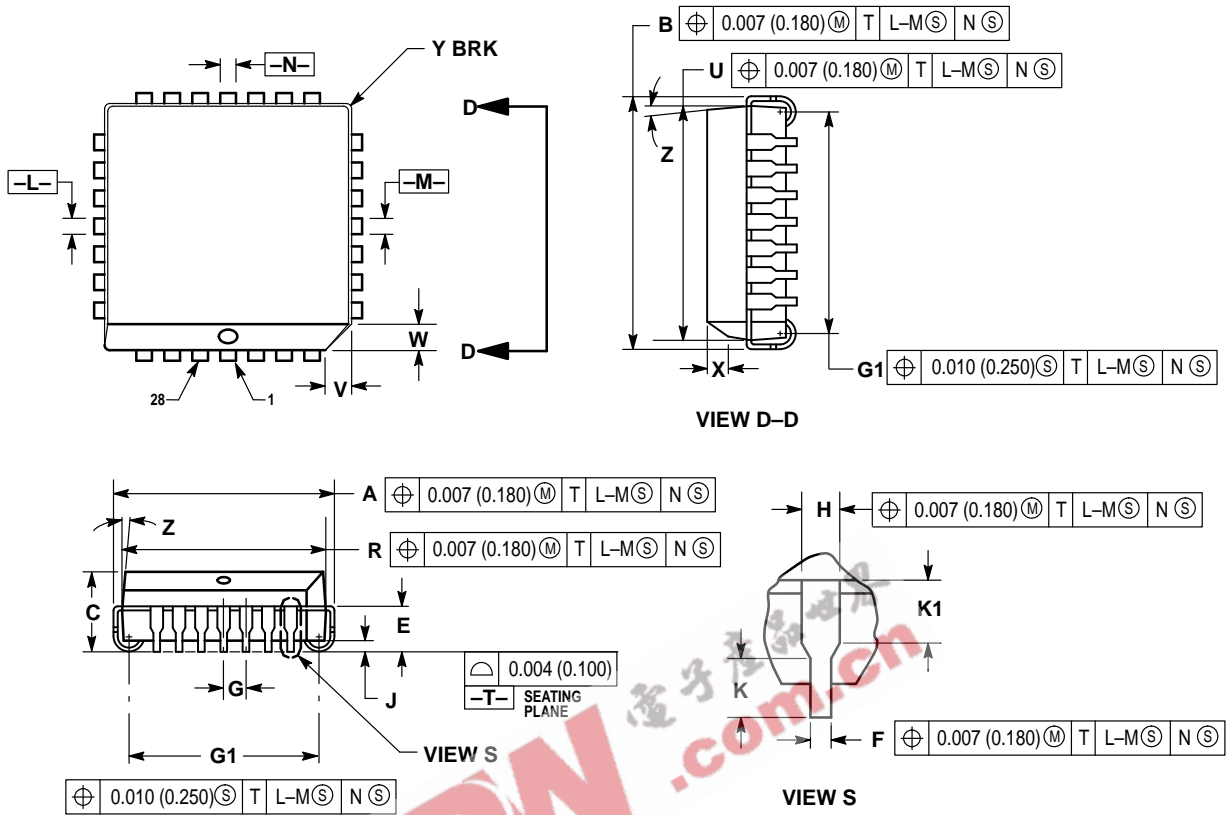

NOTES:

- DATUMS -L-, -M-, AND -N- DETERMINED WHERE TOP OF LEAD SHOULDER EXITS PLASTIC BODY AT MOLD PARTING LINE.
- DIMENSION G1, TRUE POSITION TO BE MEASURED AT DATUM -T-, SEATING PLANE.
- DIMENSIONS R AND U DO NOT INCLUDE MOLD FLASH. ALLOWABLE MOLD FLASH IS 0.010 (0.250) PER SIDE.
- DIMENSIONING AND TOLERANCING PER ANSI Y14.5M, 1982.
- CONTROLLING DIMENSION: INCH.
- THE PACKAGE TOP MAY BE SMALLER THAN THE PACKAGE BOTTOM BY UP TO 0.012 (0.300). DIMENSIONS R AND U ARE DETERMINED AT THE OUTERMOST EXTREMES OF THE PLASTIC BODY EXCLUSIVE OF MOLD FLASH, TIE BAR BURRS, GATE BURRS AND INTERLEAD FLASH, BUT INCLUDING ANY MISMATCH BETWEEN THE TOP AND BOTTOM OF THE PLASTIC BODY.
- DIMENSION H DOES NOT INCLUDE DAMBAR PROTRUSION OR INTRUSION. THE DAMBAR PROTRUSION(S) SHALL NOT CAUSE THE H DIMENSION TO BE GREATER THAN 0.037 (0.940). THE DAMBAR INTRUSION(S) SHALL NOT CAUSE THE H DIMENSION TO BE SMALLER THAN 0.025 (0.635).

DIM	INCHES		MILLIMETERS	
	MIN	MAX	MIN	MAX
A	0.485	0.495	12.32	12.57
B	0.485	0.495	12.32	12.57
C	0.165	0.180	4.20	4.57
E	0.090	0.110	2.29	2.79
F	0.013	0.019	0.33	0.48
G	0.050 BSC		1.27 BSC	
H	0.026	0.032	0.66	0.81
J	0.020	—	0.51	—
K	0.025	—	0.64	—
R	0.450	0.456	11.43	11.58
U	0.450	0.456	11.43	11.58
V	0.042	0.048	1.07	1.21
W	0.042	0.048	1.07	1.21
X	0.042	0.056	1.07	1.42
Y	—	0.020	—	0.50
Z	2°	10°	2°	10°
G1	0.410	0.430	10.42	10.92
K1	0.040	—	1.02	—

How to reach us:

USA/EUROPE: Motorola Literature Distribution;
P.O. Box 20912; Phoenix, Arizona 85036. 1-800-441-2447

JAPAN: Nippon Motorola Ltd.; Tatsumi-SPD-JLDC, Toshikatsu Otsuki,
6F Seibu-Butsuryu-Center, 3-14-2 Tatsumi Koto-Ku, Tokyo 135, Japan. 03-3521-8315

MFAX: RMFAX0@email.sps.mot.com - TOUCHTONE (602) 244-6609
INTERNET: http://Design-NET.com

HONG KONG: Motorola Semiconductors H.K. Ltd.; 8B Tai Ping Industrial Park,
51 Ting Kok Road, Tai Po, N.T., Hong Kong. 852-26629298



MC33121/D

