



300mA High Efficiency Low Quiescent Current Synchronous Buck Regulator With Z-mode

The 34726 is a high efficiency, low quiescent current (I_Q), synchronous buck regulator, implementing Freescale's innovative Z-mode architecture. Freescale's Z-mode architecture greatly improves the ripple performance during light load currents, but still maintains a low quiescent current of 65 μ A, at no load in "Sleepy" Z-mode.

The 34726 accepts an input voltage in the range of 2.7 to 5.5V, making it ideally suited for single cell Li-Ion based applications. Factory preset output voltages, ranging from 0.8V to 3.3V, reduce the number of required auxiliary components. The part is able to provide 300mA of continuous load current across the input and the output voltage ranges.

The 34726 switches at 2.0MHz to allow the use of small, surface mount inductors and capacitors to save precious board space.

The 34726 is available in the small, space saving, and low cost, 2x2 UDFN-8 packages. The part is guaranteed for operation over the -25°C to 85°C temperature range.

Features

- 94% peak efficiency
- 2.0MHz switching frequency
- 2.7V to 5.5V input voltage range
- Automatic transition to energy saving light load Z-mode (low ripple)
- Fixed output voltage options from 0.8 to 3.3V
- 65 μ A quiescent current during sleepy Z-mode
- 300mA maximum continuous output current
- Internal 2.0ms soft start
- Thermal and over-current protection
- 0.1 μ A quiescent current in shutdown (disabled)
- Ultra thin 2x2 UDFN package
- Pb-free packaging designated by suffix code FC

34726

POWER MANAGEMENT IC

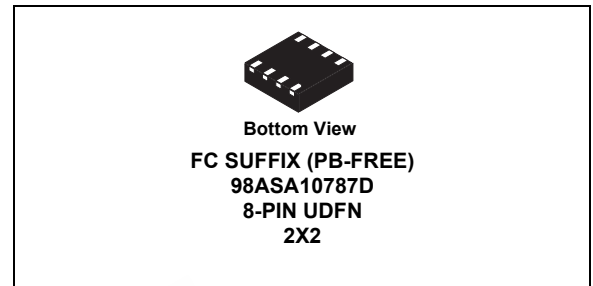

ORDERING INFORMATION		
Device	Temperature Range (T _A)	Package
MC34726AFC/R2	-25°C to 85°C	8-UDFN
MC34726BFC/R2		
MC34726CFC/R2		

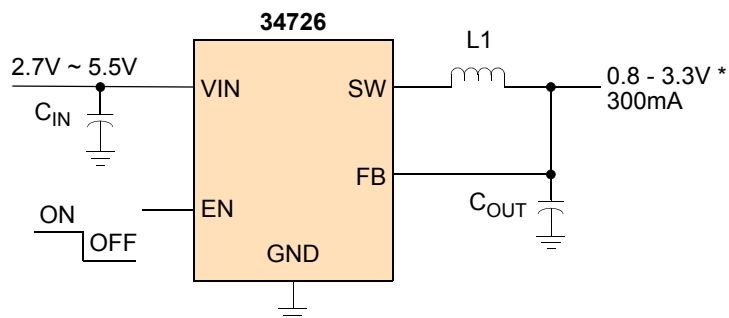

*Programmable
See table 1

Figure 1. 34726 Typical Operating Circuit

* This document contains certain information on a new product. Specifications and information herein are subject to change without notice.

DEVICE VARIATIONS

Table 1. Device Variations

Freescle Part No.	V _{IN} Range	Output Voltage ⁽¹⁾	Maximum Load Current	Switch Frequency (MHz) ⁽²⁾
MC34726AFC	2.7 - 5.5V	1.2V	300mA	2.0
MC34726BFC	2.7 - 5.5V	1.8V	300mA	2.0
MC34726CFC	3.6 - 5.5V	3.3V	300mA	2.0

Notes

1. Output voltages of: 0.8V, 0.9V, 1.0V, 1.1V, 1.3V, 1.4V, 1.5V, 1.85V, 2.0V, 2.5V options available on request. Contact Freescale sales.
2. Factory programmable at 2.0MHz or 4.0Mhz. Contact Freescale sales for availability of the 4.0MHz functionality.

EEPW 电子产品世界
.com.cn

INTERNAL BLOCK DIAGRAM

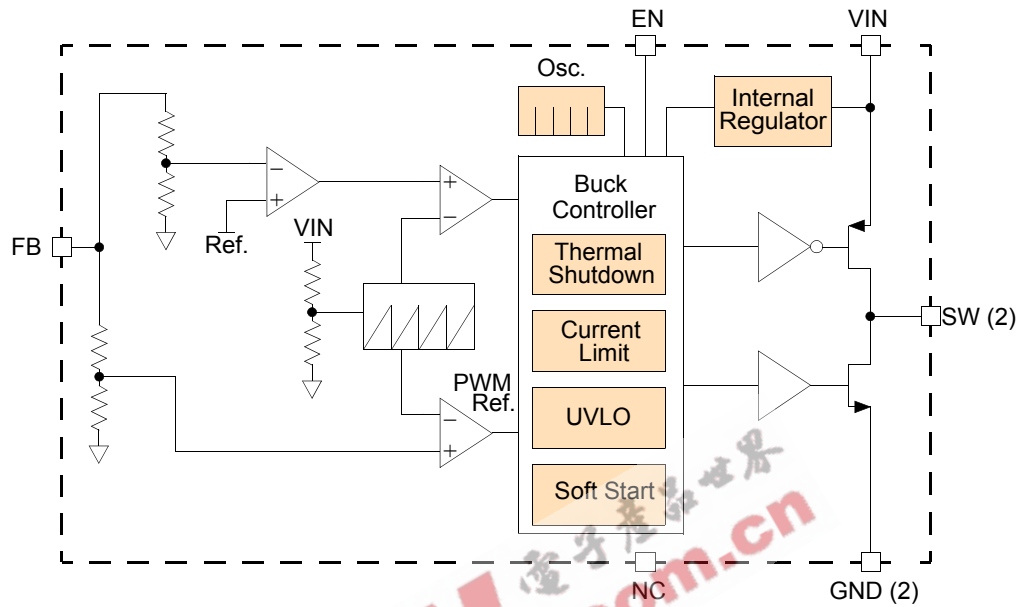

Figure 2. 34726 Simplified Internal Block Diagram

PIN CONNECTIONS

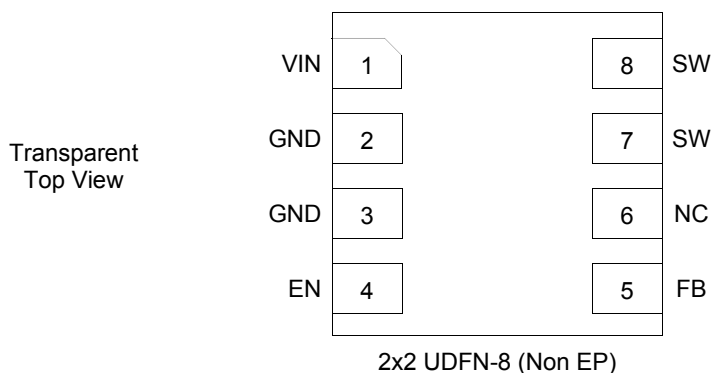

Figure 3. 34726 Pin Connections

Table 2. 34726 Pin Definitions

A functional description of each pin can be found in the Functional Pin Description section beginning on [page 10](#).

Pin Number	Pin Name	Pin Function	Formal Name	Definition
1	VIN	Input	Supply Voltage Input	Power input
2	GND	Ground	Ground	Ground
3	GND	Ground	Ground	Low noise ground
4	EN	Input	Enable	Active high enable input
5	FB	Input	Feedback Input	Feedback of the output voltage
6	NC	N/A	No Connection	Internally not connected. Connect to GND externally
7	SW	Output	Switching Node	This terminal connects to the output inductor
8	SW	Output	Switching Node	This terminal connects to the output inductor

ELECTRICAL CHARACTERISTICS

MAXIMUM RATINGS

Table 3. Maximum Ratings

All voltages are with respect to ground unless otherwise noted. Exceeding these ratings may cause a malfunction or permanent damage to the device.

Ratings	Symbol	Value	Unit
ELECTRICAL RATINGS			
All pins voltages	$V_{IN}, V_{EN}, V_{FB}, V_{SW}$	-0.3 to 6.0	V
ESD Voltage ⁽¹⁾ Human Body Model (HBM) Machine Model (MM)	V_{ESD}	±2000 ±200	V
THERMAL RATINGS			
Operating Ambient Temperature Range	T_A	-25 to +85	°C
Storage Temperature Range	T_{STG}	-25 to +150	°C
Maximum Lead Temperature ^{(2),(3)}	T_{PPRT}	Note 3	°C
Junction Temperature Operating Junction Temperature Maximum Junction Temperature	T_J	125 +150	°C
Thermal Resistance ⁽⁴⁾ Junction-to-Case Junction-to-Ambient	$R_{\theta JC}$ $R_{\theta JA}$	104 122	°C/W
Power Dissipation Continuous (Derate 3.0mW/°C and over $T_A = 70^\circ\text{C}$)	P_D	0.5	W

Notes

- ESD testing is performed in accordance with the Human Body Model (HBM) ($C_{ZAP} = 100\text{pF}$, $R_{ZAP} = 1500\Omega$), and the Machine Model (MM) ($C_{ZAP} = 200\text{pF}$, $R_{ZAP} = 0\Omega$).
- Pin soldering temperature limit is for 10 seconds maximum duration. Not designed for immersion soldering. Exceeding these limits may cause malfunction or permanent damage to the device.
- Freescle's Package Reflow capability meets Pb-free requirements for JEDEC standard J-STD-020C. For Peak Package Reflow Temperature and Moisture Sensitivity Levels (MSL). Go to www.freescale.com, search by part number [e.g. remove prefixes/suffixes and enter the core ID to view all orderable parts. (i.e. MC33xxxD enter 33xxx)], and review parametrics.
- Device mounted on the Freescale EVB test board per JEDEC DESD51-2.

STATIC ELECTRICAL CHARACTERISTICS

Table 4. Static Electrical Characteristics

Characteristics noted under conditions; $2.7V \leq V_{IN} \leq 5.5V$, $0.8V \leq V_{OUT} \leq 3.3V$, $-25^{\circ}C \leq T_A \leq 85^{\circ}C$, $C_{IN} = C_{OUT} = 4.7\mu F$, $L1 = 4.7\mu H$ (See [Figure 1](#)), unless otherwise noted. The typical specifications are measured at the following conditions; $T_A = +25^{\circ}C$, $V_{IN} = 3.6V$, $f_{SW} = 2.0MHz$ with the typical operating circuit (See [Figure 1](#)), unless otherwise noted.

Characteristic	Symbol	Min	Typ	Max	Unit
Supply Voltage	V_{IN}	2.7	-	5.5	V
Output Voltage (Factory preset)	V_{OUT}	0.8	-	3.3	V
Output Current	I_{OUT}	300	-	-	mA
Total Supply Current ⁽⁵⁾ Regulator disabled	I_{DIS}	-	0.1	1.0	μA
Quiescent Current (Switching) Sleepy Z-mode and $I_{LOAD} = 0mA$	I_Q	-	65	85	μA
Current Limit Current rising at high side	I_{PK}	-	450	-	mA
Output Voltage Accuracy (% of output voltage) Over load and temperature	ΔV_{OUT}	-3%	-	3%	V_{OUT}
UVLO Threshold ⁽⁶⁾ $V_{IN}: 2.7 - 5.5V$ V_{IN} rising V_{IN} falling	V_{UVLO}	- 2.5	- -	2.7 -	V
Enable Voltage Regulator operating Regulator shutdown	V_{EN}	1.6 -	- -	- 0.4	V
High Side Power MOSFET On Resistance $V_{IN} = 3.6V$, $V_{OUT} = 1.8V$, $T_A = 40^{\circ}C$, $I_{LOAD} = 150mA$	$R_{DS(ON)H}$	-	250	-	$m\Omega$
Low Side Power MOSFET On Resistance $V_{IN} = 3.6V$, $V_{OUT} = 1.8V$, $T_A = 40^{\circ}C$, $I_{LOAD} = 150mA$	$R_{DS(ON)L}$	-	350	-	$m\Omega$
Load Regulation $1mA < I_{LOAD} < 300mA$ and $V_{OUT} = 1.8V$	$\Delta V_{OUT}/\Delta I_{OUT}$	-	0.5	-	%
Line Regulation $V_{IN} = 2.7V$ to $5.5V$	$\Delta V_{OUT}/\Delta V_{IN}$	-	0.5	-	%
Start-up Overshoot (% of output voltage) $I_{LOAD} = 0mA$, $V_{OUT} = 1.8V$ and $C_{OUT} = 4.7\mu F$	V_{STO}	-	3%	-	V_{OUT}
Thermal Shutdown Threshold (Junction Temperature)	T_{STDN}	-	140	-	$^{\circ}C$
Thermal Shutdown Hysteresis (Junction Temperature)	T_{HYSTR}	-	10	-	$^{\circ}C$

Notes

- Maximum I_{DIS} measured at $V_{IN} = 3.6V$ and $T_A = 25^{\circ}C$.
- For a product with a V_{OUT} of 3.3V and a V_{IN} minimum less than 3.6V, the V_{OUT} value will track (drop below 3.3V) V_{IN} down to a value of 2.5V, where the UVLO shutdown mechanism will activate.

DYNAMIC ELECTRICAL CHARACTERISTICS**Table 5. Dynamic Electrical Characteristics**

Characteristics noted under conditions; $2.7V \leq V_{IN} \leq 5.5V$, $0.8V \leq V_{OUT} \leq 3.3V$, $-20^{\circ}C \leq T_A \leq 85^{\circ}C$, $C_{IN} = C_{OUT} = 4.7\mu F$, $L1 = 4.7\mu H$ (See [Figure 1](#)), unless otherwise noted. The typical specifications are measured at the following conditions; $T_A = +25^{\circ}C$, $V_{IN} = 3.6V$, $f_{SW} = 2.0MHz$ with the typical operating circuit (See [Figure 1](#)), unless otherwise noted.

Characteristic	Symbol	Min	Typ	Max	Unit
Switching Frequency ⁽⁷⁾	f_{SW}	1.8	2.0	2.2	MHz
Maximum Duty Cycle ⁽⁸⁾ Measured from SW pin	D_{MAX}	95	-	100	%
Internal Soft-start Timer V_{OUT} Rise Time	t_s	-	2.0	-	ms

Notes

7. f_{SW} can be factory programmed to $\pm 20\%$ of nominal 2.0MHz.
8. The maximum duty limits the range of output voltages achievable for a given input voltage.

EEPW 电子产品世界 .com.cn

ELECTRICAL PERFORMANCE CURVES

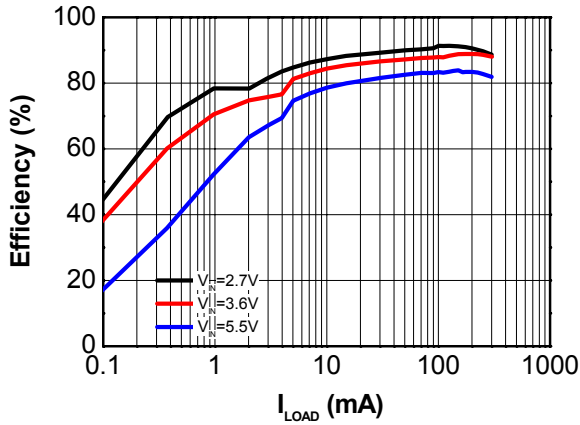

Figure 4. Efficiency vs. Load Current
 $V_{IN} = 3.6V$, $V_{OUT} = 1.8V$, $T_A = 25^\circ C$

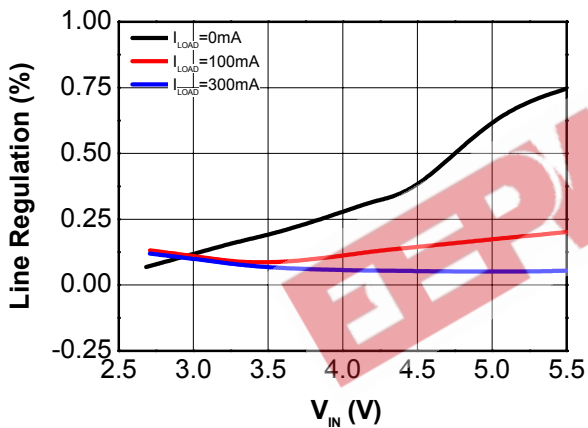

Figure 5. Line Regulation
 V_{IN} is 2.7V to 5.5V and V_{OUT} is 1.8V, $T_A = 25^\circ C$

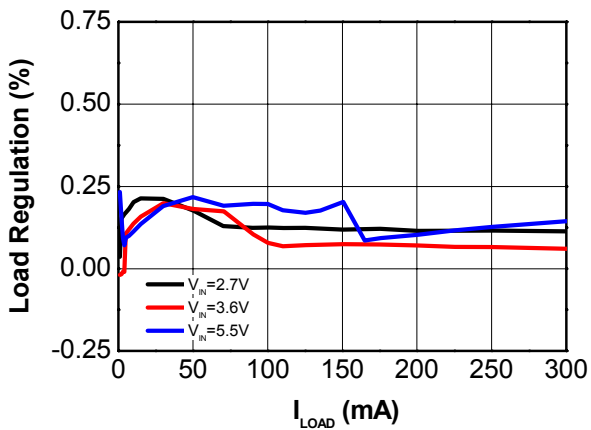

Figure 6. Load Regulation
 $1mA < I_{LOAD} < 300mA$, $V_{OUT} = 1.8V$

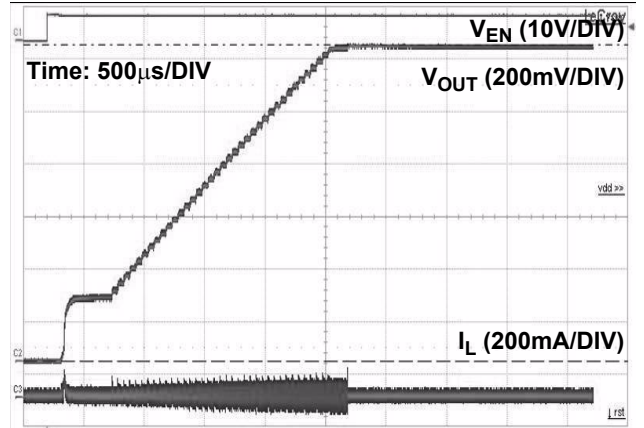

Figure 7. Start-up Response
 $I_{LOAD} = 0mA$, $V_{OUT} = 1.2V$

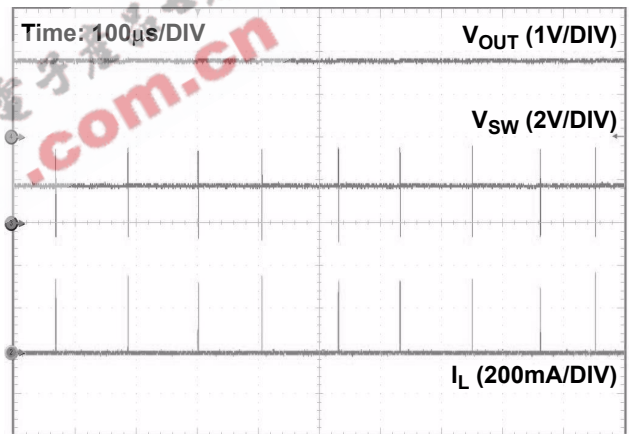

Figure 8. Sleepy Z-Mode™ Switching Waveforms
 $V_{IN} = 3.6V$, $V_{OUT} = 1.8V$ and $I_{LOAD} = 1.0mA$

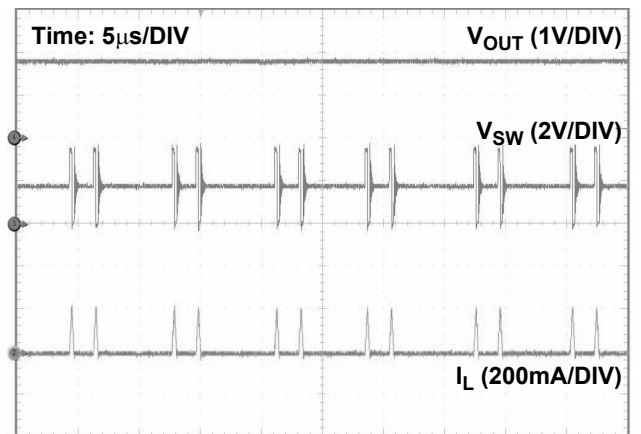

Figure 9. Z-Mode™ Switching Waveforms
 $V_{IN} = 3.6V$, $V_{OUT} = 1.8V$ and $I_{LOAD} = 10mA$

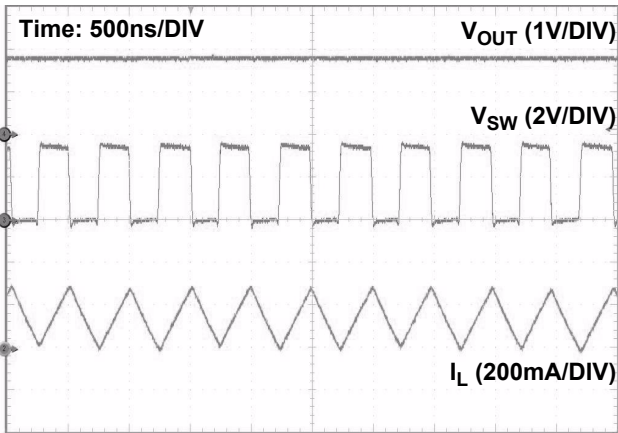

Figure 10. CCM Switching Waveforms
 $V_{IN} = 3.6V$, $V_{OUT} = 1.8V$ and $I_{LOAD} = 150mA$

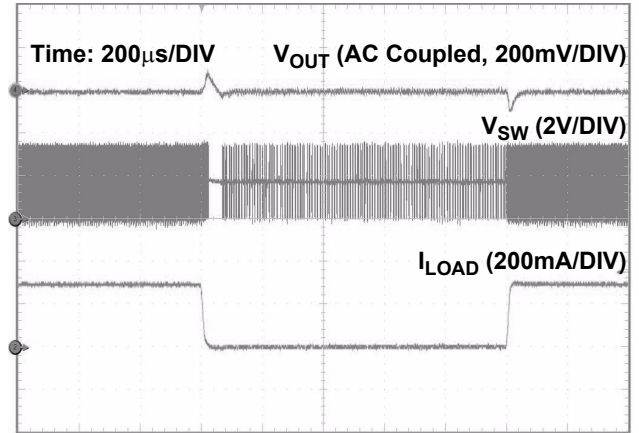

Figure 12. Load Transient in Z-Mode™
 $V_{IN} = 3.6V$, $I_{LOAD} = 10mA$ to $300mA$

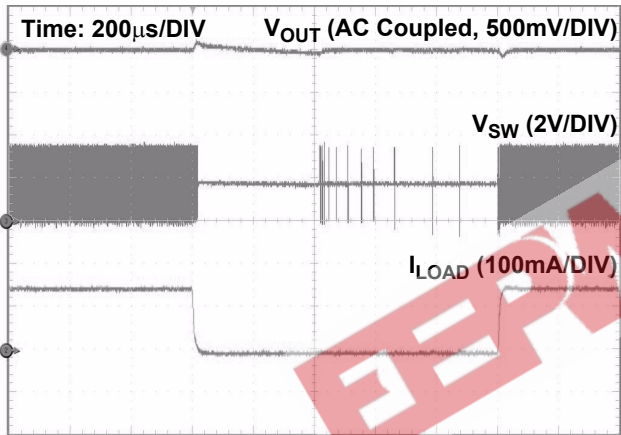

Figure 11. Load Transient in Sleepy Z-Mode™
 $V_{IN} = 3.6V$, $I_{LOAD} = 1mA$ to $150mA$

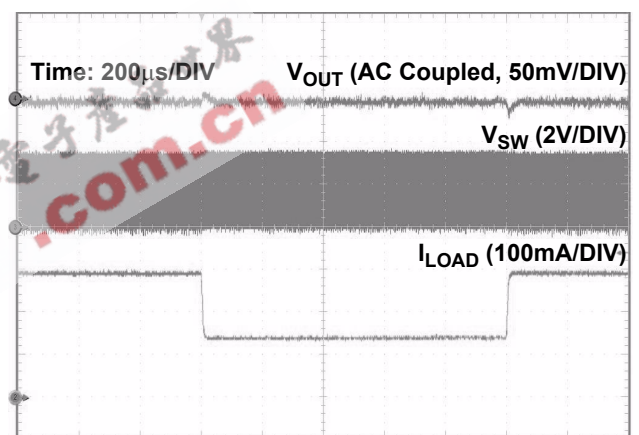

Figure 13. Load Transient in CCM
 $V_{IN} = 3.6V$, $I_{LOAD} = 150mA$ to $300mA$

FUNCTIONAL DESCRIPTION

INTRODUCTION

The 34726 is a high efficiency, synchronous, buck regulator, utilizing a voltage mode control architecture with feed forward. It is capable of providing a 300mA load current for output voltages of 0.8V to 3.3V, from a single input voltage rail between 2.7V and 5.5V.

In a buck converter, most of the losses at high output loads are due to conduction losses in the power train, but at light output loads, the conduction losses are reduced and most of the losses become switching losses. Using Freescale's Z-mode architecture, the 34726, at light output loads, will smoothly transition into a lower switching frequency, thus improving its efficiency.

FUNCTIONAL PIN DESCRIPTION

SUPPLY VOLTAGE INPUT (VIN)

2.7V to 5.5V DC power input. Bypass with a 4.7 μ F ceramic capacitor as close as possible to the VIN and GND pins.

GROUND (GND)

Ground.

ENABLE (EN)

Active high enable input. EN is over-voltage protected to 6.0V, independent of the supply voltage. Drive with a logic high signal (or connect to VIN) for normal operation. Drive with a logic low signal, or connect to GND will disable the 34726.

FEEDBACK INPUT (FB)

Feedback of the output voltage.

SWITCHING NODE (SW)

This terminal connects to the output inductor. The node internally connects the drain of both high side MOSFET and low side MOSFET.

NO CONNECTION (NC)

Internally not connected. Connect to GND externally.

FUNCTIONAL INTERNAL BLOCK DESCRIPTION

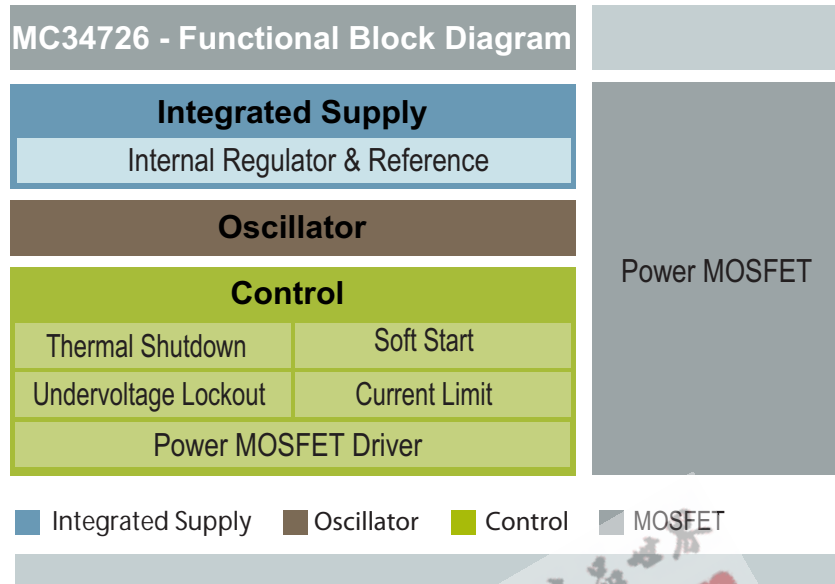

Figure 14. 34726 Functional Internal Block Diagram

INTEGRATED SUPPLY

The soft-start sequence also occurs upon recovery from any fault condition.

INTERNAL REGULATOR AND REFERENCE

The internal regulator and reference block steps down the high input voltage to lower voltage, to power all the internal blocks, and provides the reference voltage for the other internal blocks.

UVLO

The UVLO block monitors the input voltage. Once the input voltage is lower than the falling threshold voltage, this block turns off the device, to avoid unpredictable circuit behavior.

OSCILLATOR

The oscillator block provides 2.0MHz clock signal to the controller.

CURRENT LIMIT

The current limit block monitors the inductor current. When the peak inductor current reaches its current limit, this block turns off the high side MOSFET, to prevent the device and external components from damage.

CONTROLLER

THERMAL SHUTDOWN

The thermal shutdown block monitors the die temperature. Once the die temperature reaches its threshold, this block turns off the device to prevent the further die temperature rise.

POWER-MOSFET DRIVER

The power-MOSFET-driver block controls the phase of the driver signals and enhances the drive capability of these

SOFT-START

The soft-start block controls the output voltage ramp after the device is enabled, to limit the in-rush current. The start-up time is internally set to approximately 2.0ms, and is independent of input voltage, output voltage, or load current.

POWER-MOSFET

The power-MOSFET block contains two power MOSFETs. One is a PMOS that passes the current from the input to the output, and the other one is an NMOS that provides the inductor current loop when PMOS is turned off.

FUNCTIONAL DEVICE OPERATION

OPERATIONAL MODES

Z-MODE OPERATION

The 34726 operates as a typical fixed frequency, PWM regulator, at moderate to heavy load currents. As the load is decreased, such that operation transitions from continuous conduction mode (CCM) to discontinuous conduction mode (DCM), the duty cycle is reduced until it approaches 85% of the full load duty cycle. At this point the 34726 transitions into Z-mode operation, where the Z-mode Factor is 0.85. In Z-mode, the regulator skips pulses whenever the duty cycle is

below 85% of the CCM duty cycle. As the load decreases, this pulse skipping reduces the switching frequency and the switching losses thus improving efficiency. For example, if a light load demanded a 30% duty cycle at 2.0MHz, with Z-mode this same load will require only $(0.3/0.85)^2 \times 2.0\text{MHz} = 0.249\text{MHz}$ switching frequency, hence switching losses will be reduced by almost ten fold. [Figure 15](#) illustrates the transition to and the exit from Z-mode.

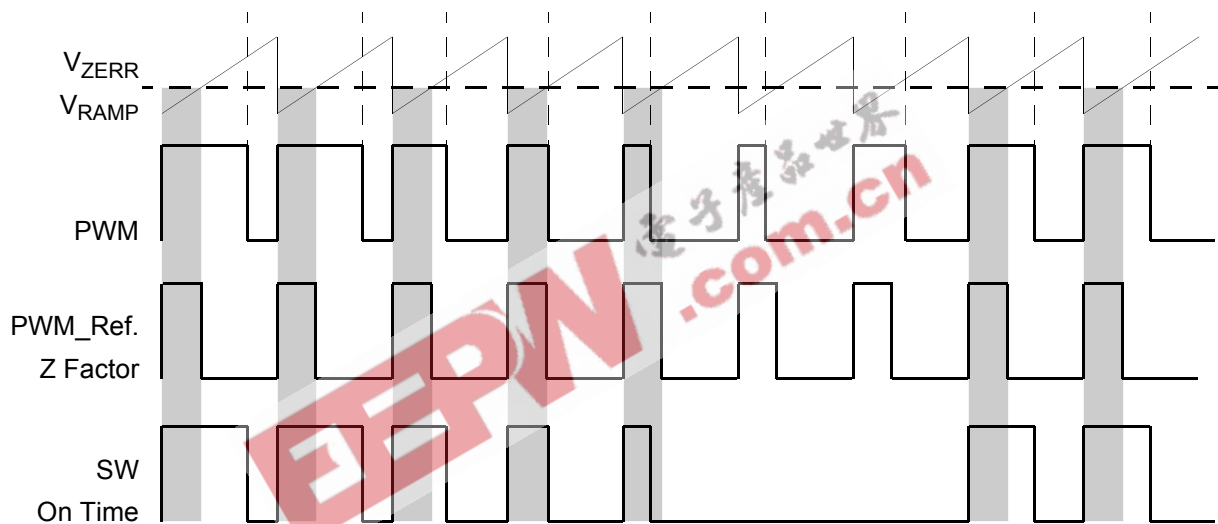

Figure 15. Z-mode Operation

SLEEPY Z-MODE OPERATION

To improve low current efficiency, the 34726 transitions into the Sleepy Z-mode at load currents of approximately 1.0mA and lower. This is accomplished by powering down

internal circuit blocks to lower the device's quiescent current. Additionally, the oscillator frequency drops to 250kHz and the low side switch is turned off to emulate the operation of an asynchronous buck converter.

DETAILED FUNCTIONAL DEVICE OPERATION

OVER-CURRENT PROTECTION

The 34726 implements two layers of protection during overload conditions. The first is a current limit feature to prevent the device and external components from damage. When the peak inductor current reaches the over-current limit, nominally 450mA, the high side MOSFET turns off to provide cycle by cycle protection. If the over-current condition persists and the die temperature surpasses the over-temperature protection (OTP) threshold, this second layer of protection shuts down the device.

SHORT-CIRCUIT PROTECTION

When a short-circuit condition occurs on the output, typical regulators will tend to operate at maximum duty cycle. This condition can saturate the inductor and produce severe peak currents, resulting in damage to the device. The 34726 avoids this scenario by detecting output voltages below 0.5V. Upon detection, the part re-starts continuously until the short circuit condition is removed, or the part surpasses its OTP threshold.

OVER-TEMPERATURE PROTECTION

To limit its operating temperature, the 34726 shuts down if the junction temperature of the switching MOSFET surpasses 140°C. If the junction temperature subsequently drops to 130°C, the 34726 re-starts.

SOFT-START OPERATION

To limit the in-rush current, an internal timer controls the output voltage ramp after the part is enabled. The start-up time is internally set to approximately 2.0ms and is independent of input voltage, output voltage, or load current.

The soft-start sequence also occurs upon recovery from any fault condition.

UNDER-VOLTAGE LOCK-OUT

The UVLO threshold is set to 2.7V for rising V_{IN} , and to 2.5V for falling V_{IN} . For a V_{OUT} of 3.3V, the V_{OUT} value will track V_{IN} below 3.6V until the 2.5V falling V_{IN} threshold is reached.

If the UVLO falling threshold is met, the part shuts down and will power up again with soft-start, when the UVLO rising threshold is surpassed.

EEPW 电子產品世界
.com.cn

TYPICAL APPLICATIONS

APPLICATION INFORMATION

INPUT CAPACITOR

The input capacitor is used to minimize the input voltage transient that may cause instability when the load transient current is high. Typically a 4.7 μ F X5R ceramic capacitor is sufficient for most applications.

OUTPUT CAPACITOR

For stable operation and low output voltage ripple, an X5R ceramic capacitor of 4.7 μ F minimum value is needed.

Depending on the load transient current, a larger capacitance may be required.

INDUCTOR SELECTION

A 4.7 μ H low DC resistance inductor is typically used for the 34726 to guarantee the system stable operation.

TYPICAL APPLICATIONS

1.2V OUTPUT DC/DC CONVERTOR

Figure 16 shows a typical application using 34726A. C_{IN} and C_{OUT} are typically 4.7 μ F/X5R ceramic capacitors. L1 is typically a 4.7 μ H low DC resistance inductor. The FB

connects to the output directly for monitoring the output voltage. Normally, the EN pin connects to the input supply directly to enable the regulator.

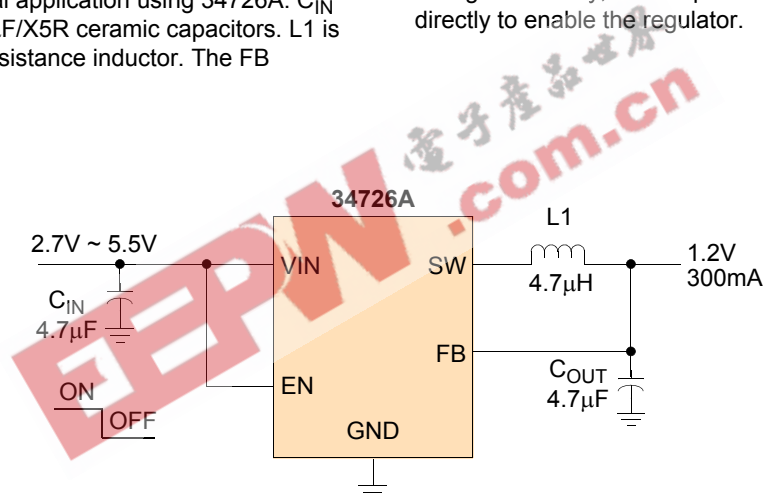
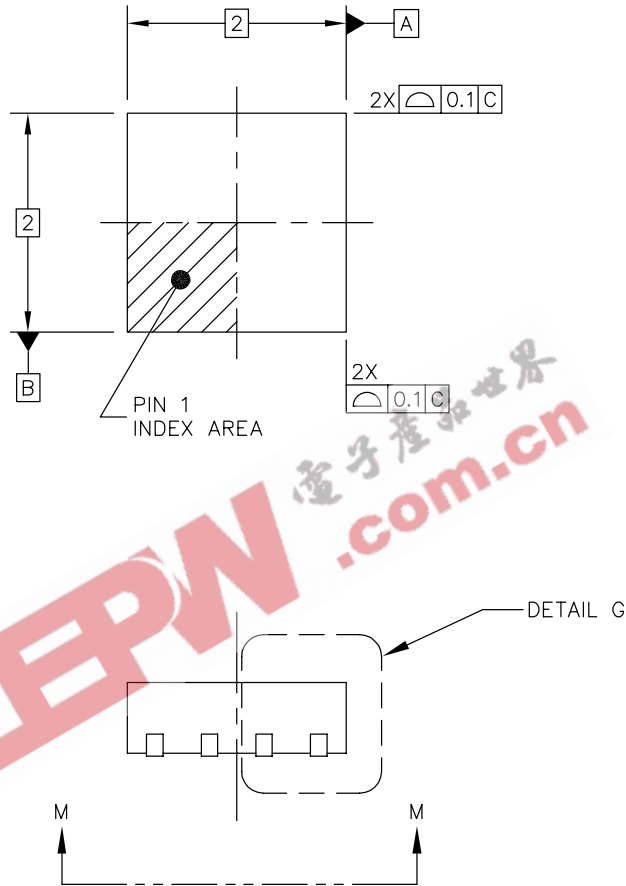

Figure 16. 1.2V/300mA DC/DC convertor

PACKAGE DIMENSIONS

For the most current package revision, visit www.freescale.com and perform a keyword search using the "98A" listed below.



© FREESCALE SEMICONDUCTOR, INC. ALL RIGHTS RESERVED.	MECHANICAL OUTLINE	PRINT VERSION NOT TO SCALE	
TITLE: PLASTIC ULTRA-THIN FINE PITCH DUAL FLAT NON-LEADED (UDFN) PACKAGE, 8 TERMINAL, 2 X 2 X 0.65, 0.5 PITCH	DOCUMENT NO: 98ASA10787D	REV: A	
	CASE NUMBER: 1944-02	10 DEC 2007	
	STANDARD: NON-JEDEC		

FC SUFFIX
12-PIN
98ASA10787D
REVISION A

TYPICAL APPLICATIONS
PACKAGE DIMENSIONS

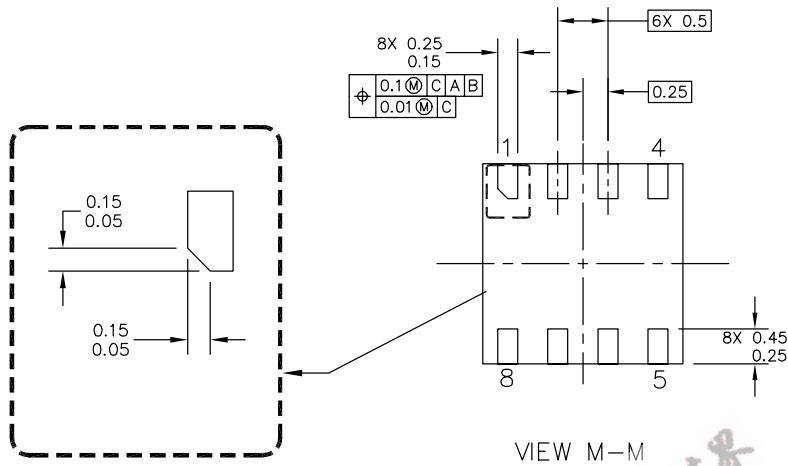

PIN 1 BACKSIDE IDENTIFIER

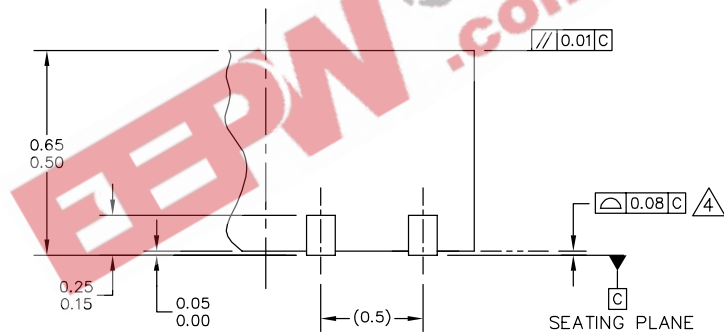

DETAIL G
VIEW ROTATED 90° CW

© FREESCALE SEMICONDUCTOR, INC. ALL RIGHTS RESERVED.	MECHANICAL OUTLINE	PRINT VERSION NOT TO SCALE	
TITLE: PLASTIC ULTRA-THIN FINE PITCH DUAL FLAT NON-LEADED (UDFN) PACKAGE, 8 TERMINAL, 2 X 2 X 0.65, 0.5 PITCH	DOCUMENT NO: 98ASA10787D	REV: A	
	CASE NUMBER: 1944-02	10 DEC 2007	
	STANDARD: NON-JEDEC		

FC SUFFIX
12-PIN
98ASA10787D
REVISION A

NOTES:

1. ALL DIMENSIONS ARE IN MILLIMETERS.
2. DIMENSIONING AND TOLERANCING PER ASME Y14.5M-1994.
3. THE COMPLETE JEDEC DESIGNATOR FOR THIS PACKAGE IS UF-PSON.
4.  COPLANARITY APPLIES TO LEADS.
5. MIN. METAL GAP SHOULD BE 0.2 MM.



© FREESCALE SEMICONDUCTOR, INC. ALL RIGHTS RESERVED.	MECHANICAL OUTLINE	PRINT VERSION NOT TO SCALE	
TITLE: PLASTIC ULTRA-THIN FINE PITCH DUAL FLAT NON-LEADED (UDFN) PACKAGE, 8 TERMINAL, 2 X 2 X 0.65, 0.5 PITCH	DOCUMENT NO: 98ASA10787D	REV: A	
	CASE NUMBER: 1944-02	10 DEC 2007	
	STANDARD: NON-JEDEC		

FC SUFFIX
12-PIN
98ASA10787D
REVISION A

REVISION HISTORY

REVISION	DATE	DESCRIPTION OF CHANGES
1.0	5/2008	• Initial Release

EEPW 电子产品世界
.com.cn

How to Reach Us:

Home Page:

www.freescale.com

Web Support:

<http://www.freescale.com/support>

USA/Europe or Locations Not Listed:

Freescale Semiconductor, Inc.
Technical Information Center, EL516
2100 East Elliot Road
Tempe, Arizona 85284
+1-800-521-6274 or +1-480-768-2130
www.freescale.com/support

Europe, Middle East, and Africa:

Freescale Halbleiter Deutschland GmbH
Technical Information Center
Schatzbogen 7
81829 Muenchen, Germany
+44 1296 380 456 (English)
+46 8 52200080 (English)
+49 89 92103 559 (German)
+33 1 69 35 48 48 (French)
www.freescale.com/support

Japan:

Freescale Semiconductor Japan Ltd.
Headquarters
ARCO Tower 15F
1-8-1, Shimo-Meguro, Meguro-ku,
Tokyo 153-0064
Japan
0120 191014 or +81 3 5437 9125
support.japan@freescale.com

Asia/Pacific:

Freescale Semiconductor Hong Kong Ltd.
Technical Information Center
2 Dai King Street
Tai Po Industrial Estate
Tai Po, N.T., Hong Kong
+800 2666 8080
support.asia@freescale.com

For Literature Requests Only:

Freescale Semiconductor Literature Distribution Center
P.O. Box 5405
Denver, Colorado 80217
1-800-441-2447 or 303-675-2140
Fax: 303-675-2150
LDCForFreescaleSemiconductor@hibbertgroup.com

Information in this document is provided solely to enable system and software implementers to use Freescale Semiconductor products. There are no express or implied copyright licenses granted hereunder to design or fabricate any integrated circuits or integrated circuits based on the information in this document.

Freescale Semiconductor reserves the right to make changes without further notice to any products herein. Freescale Semiconductor makes no warranty, representation or guarantee regarding the suitability of its products for any particular purpose, nor does Freescale Semiconductor assume any liability arising out of the application or use of any product or circuit, and specifically disclaims any and all liability, including without limitation consequential or incidental damages. "Typical" parameters that may be provided in Freescale Semiconductor data sheets and/or specifications can and do vary in different applications and actual performance may vary over time. All operating parameters, including "Typicals", must be validated for each customer application by customer's technical experts. Freescale Semiconductor does not convey any license under its patent rights nor the rights of others. Freescale Semiconductor products are not designed, intended, or authorized for use as components in systems intended for surgical implant into the body, or other applications intended to support or sustain life, or for any other application in which the failure of the Freescale Semiconductor product could create a situation where personal injury or death may occur. Should Buyer purchase or use Freescale Semiconductor products for any such unintended or unauthorized application, Buyer shall indemnify and hold Freescale Semiconductor and its officers, employees, subsidiaries, affiliates, and distributors harmless against all claims, costs, damages, and expenses, and reasonable attorney fees arising out of, directly or indirectly, any claim of personal injury or death associated with such unintended or unauthorized use, even if such claim alleges that Freescale Semiconductor was negligent regarding the design or manufacture of the part.

Freescale™ and the Freescale logo are trademarks of Freescale Semiconductor, Inc. All other product or service names are the property of their respective owners.

© Freescale Semiconductor, Inc., 2008. All rights reserved.