

MC3487 QUADRUPLE DIFFERENTIAL LINE DRIVER

SLLS098C – MAY 1980 – REVISED FEBRUARY 2004

- Meets or Exceeds Requirements of ANSI TIA/EIA-422-B and ITU Recommendation V.11
- 3-State, TTL-Compatible Outputs
- Fast Transition Times
- High-Impedance Inputs
- Single 5-V Supply
- Power-Up and Power-Down Protection

D, N, OR NS PACKAGE
(TOP VIEW)

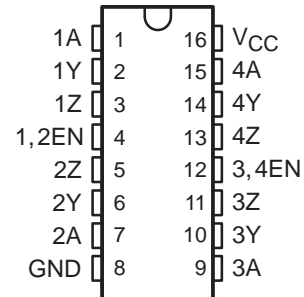

description/ordering information

The MC3487 offers four independent differential line drivers designed to meet the specifications of ANSI TIA/EIA-422-B and ITU Recommendation V.11. Each driver has a TTL-compatible input buffered to reduce current and minimize loading.

The driver outputs utilize 3-state circuitry to provide high-impedance states at any pair of differential outputs when the appropriate output enable is at a low logic level. Internal circuitry is provided to ensure the high-impedance state at the differential outputs during power-up and power-down transition times, provided the output enable is low.

The MC3487 is designed for optimum performance when used with the MC3486 quadruple line receiver. It is supplied in a 16-pin dual-in-line package and operates from a single 5-V supply.

ORDERING INFORMATION

T _A	PACKAGE†		ORDERABLE PART NUMBER	TOP-SIDE MARKING
0°C to 70°C	PDIP – N	Tube	MC3487N	MC3487N
	SOIC – D	Tube	MC3487D	MC3487
		Tape and reel	MC3487DR	
	SOP – NS	Tape and reel	MC3487NSR	MC3487

† Package drawings, standard packing quantities, thermal data, symbolization, and PCB design guidelines are available at www.ti.com/sc/package.

FUNCTION TABLE
(each driver)

INPUT	OUTPUT ENABLE	OUTPUTS	
		Y	Z
H	H	H	L
L	H	L	H
X	L	Z	Z

H = TTL high level, L = TTL low level,
X = irrelevant, Z = High impedance



Please be aware that an important notice concerning availability, standard warranty, and use in critical applications of Texas Instruments semiconductor products and disclaimers thereto appears at the end of this data sheet.

PRODUCTION DATA information is current as of publication date. Products conform to specifications per the terms of Texas Instruments standard warranty. Production processing does not necessarily include testing of all parameters.

**TEXAS
INSTRUMENTS**

POST OFFICE BOX 655303 • DALLAS, TEXAS 75265

Copyright © 2004, Texas Instruments Incorporated

MC3487 QUADRUPLE DIFFERENTIAL LINE DRIVER

SLLS098C - MAY 1980 - REVISED FEBRUARY 2004

logic diagram (positive logic)

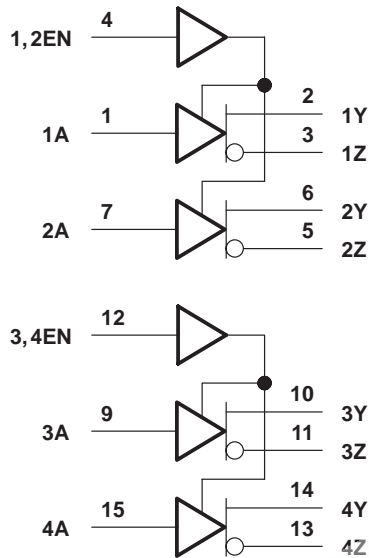

schematics of inputs and outputs

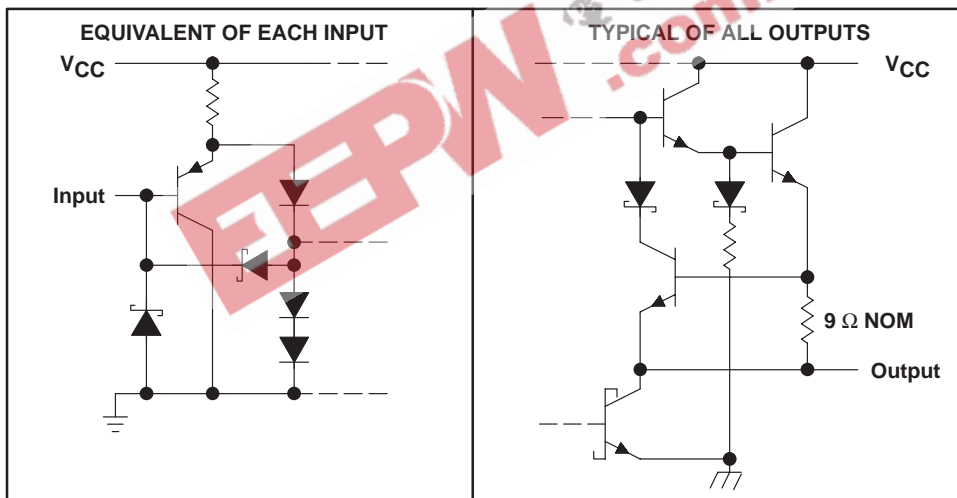

MC3487 QUADRUPLE DIFFERENTIAL LINE DRIVER

SLLS098C – MAY 1980 – REVISED FEBRUARY 2004

absolute maximum ratings over operating free-air temperature range (unless otherwise noted)†

Supply voltage, V_{CC} (see Note 1)	8 V	
Input voltage, V_I	5.5 V	
Output voltage, V_O	7 V	
Package thermal impedance, θ_{JA} (see Notes 2 and 3):	D package	73°C/W
	N package	67°C/W
	NS package	64°C/W
Operating virtual junction temperature, T_J	150°C	
Storage temperature range, T_{stg}	–65°C to 150°C	

† Stresses beyond those listed under “absolute maximum ratings” may cause permanent damage to the device. These are stress ratings only, and functional operation of the device at these or any other conditions beyond those indicated under “recommended operating conditions” is not implied. Exposure to absolute-maximum-rated conditions for extended periods may affect device reliability.

- NOTES: 1. All voltage values, except differential output voltage, V_{OD} , are with respect to the network ground terminal.
 2. Maximum power dissipation is a function of $T_J(\text{max})$, θ_{JA} , and T_A . The maximum allowable power dissipation at any allowable ambient temperature is $P_D = (T_J(\text{max}) - T_A)/\theta_{JA}$. Operating at the absolute maximum T_J of 150°C can affect reliability.
 3. The package thermal impedance is calculated in accordance with JESD 51-7.

recommended operating conditions

	MIN	NOM	MAX	UNIT
V_{CC} Supply voltage	4.75	5	5.25	V
V_{IH} High-level input voltage	2			V
V_{IL} Low-level input voltage			0.8	V
T_A Operating free-air temperature	0		70	°C

MC3487

QUADRUPLE DIFFERENTIAL LINE DRIVER

SLLS098C – MAY 1980 – REVISED FEBRUARY 2004

electrical characteristics over recommended ranges of supply voltage and operating free-air temperature (unless otherwise noted)

PARAMETER		TEST CONDITIONS		MIN	MAX	UNIT
V_{IK}	Input clamp voltage	$I_I = -18 \text{ mA}$			-1.5	V
V_{OH}	High-level output voltage	$V_{IL} = 0.8 \text{ V}$,	$V_{IH} = 2 \text{ V}$,	$I_{OH} = -20 \text{ mA}$		V
V_{OL}	Low-level output voltage	$V_{IL} = 0.8 \text{ V}$,	$V_{IH} = 2 \text{ V}$,	$I_{OL} = 48 \text{ mA}$		V
$ V_{OD} $	Differential output voltage	$R_L = 100 \Omega$,	See Figure 1		2	
$\Delta V_{OD} $	Change in magnitude of differential output voltage†	$R_L = 100 \Omega$,	See Figure 1		± 0.4	V
V_{OC}	Common-mode output voltage‡	$R_L = 100 \Omega$,	See Figure 1		3	V
$\Delta V_{OC} $	Change in magnitude of common-mode output voltage†	$R_L = 100 \Omega$,	See Figure 1		± 0.4	V
I_O	Output current with power off	$V_{CC} = 0$	$V_O = 6 \text{ V}$	100		μA
			$V_O = -0.25 \text{ V}$	-100		
I_{OZ}	High-impedance-state output current	Output enables at 0.8 V	$V_O = 2.7 \text{ V}$	100		μA
			$V_O = 0.5 \text{ V}$	-100		
I_I	Input current at maximum input voltage	$V_I = 5.5 \text{ V}$		100		μA
I_{IH}	High-level input current	$V_I = 2.7 \text{ V}$		50		μA
I_{IL}	Low-level input current	$V_I = 0.5 \text{ V}$		-400		μA
I_{OS}	Short-circuit output current§	$V_I = 2 \text{ V}$		-40	-140	mA
I_{CC}	Supply current (all drivers)	Outputs disabled		105		mA
		Outputs enabled, No load		85		

† $\Delta|V_{OD}|$ and $\Delta|V_{OC}|$ are the changes in magnitude of V_{OD} and V_{OC} , respectively, that occur when the input is changed from a high level to a low level.

‡ In ANSI Standard TIA/EIA-422-B, V_{OC} , which is the average of the two output voltages with respect to ground, is called output offset voltage, V_{OS} .

§ Only one output at a time should be shorted, and duration of the short circuit should not exceed one second.

switching characteristics over recommended operating free-air temperature range, $V_{CC} = 5 \text{ V}$

PARAMETER		TEST CONDITIONS		MIN	MAX	UNIT
t_{PLH}	Propagation delay time, low- to high-level output	$C_L = 15 \text{ pF}$,	See Figure 2	20		ns
t_{PHL}	Propagation delay time, high- to low-level output			20		
t_{sk}	Skew time	$C_L = 15 \text{ pF}$,	See Figure 2	6		ns
$t_t(OD)$	Differential-output transition time	$C_L = 15 \text{ pF}$,	See Figure 3	20		ns
t_{PZH}	Output enable time to high level	$C_L = 50 \text{ pF}$,	See Figure 4	30		ns
t_{PZL}	Output enable time to low level			30		
t_{PHZ}	Output disable time from high level	$C_L = 50 \text{ pF}$,	See Figure 4	25		ns
t_{PLZ}	Output disable time from low level			30		

PARAMETER MEASUREMENT INFORMATION

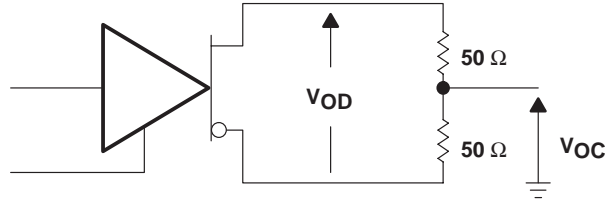
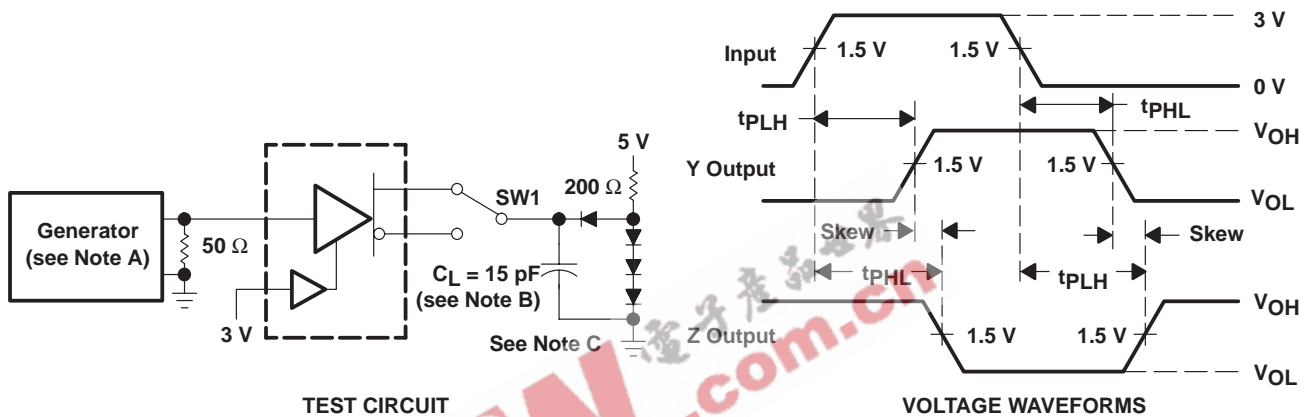
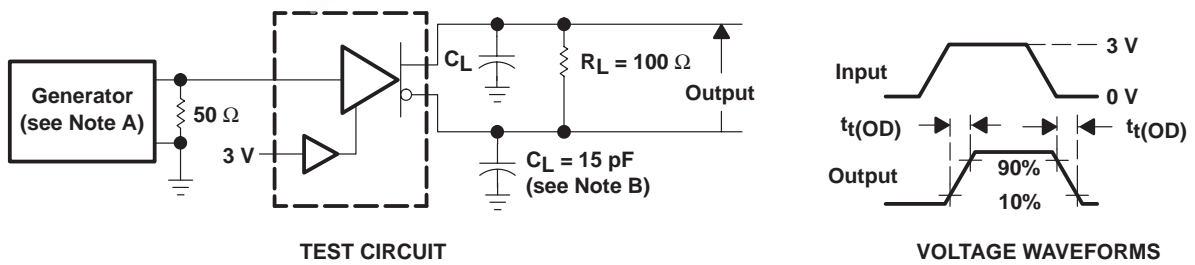

Figure 1. Differential and Common-Mode Output Voltages



- NOTES: A. The input pulse is supplied by a generator having the following characteristics: $t_r \leq 5$ ns, $t_f \leq 5$ ns, $PRR \leq 1$ MHz, duty cycle = 50%, $Z_O = 50 \Omega$.
 B. C_L includes probe and stray capacitance.
 C. All diodes are 1N916 or 1N3064.

Figure 2. Test Circuit and Voltage Waveforms



- NOTES: A. The input pulse is supplied by a generator having the following characteristics: $t_r \leq 5$ ns, $t_f \leq 5$ ns, $PRR \leq 1$ MHz, duty cycle = 50%, $Z_O = 50 \Omega$.
 B. C_L includes probe and stray capacitance.

Figure 3. Test Circuit and Voltage Waveforms

MC3487 QUADRUPLE DIFFERENTIAL LINE DRIVER

SLLS098C – MAY 1980 – REVISED FEBRUARY 2004

PARAMETER MEASUREMENT INFORMATION

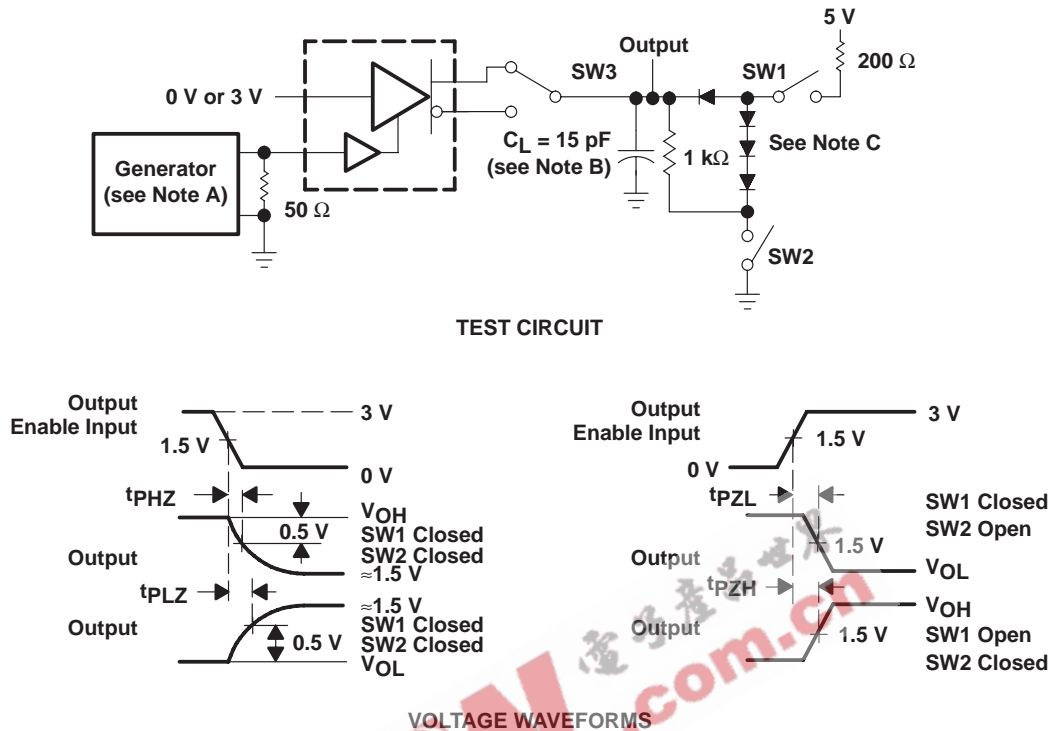

- NOTES: A. The input pulse is supplied by a generator having the following characteristics: $t_r \leq 5$ ns, $t_f \leq 5$ ns, $PRR \leq 1$ MHz, duty cycle = 50%, $Z_0 = 50 \Omega$.
- B. C_L includes probe and stray capacitance.
- C. All diodes are 1N916 or 1N3064.

Figure 4. Driver Test Circuit and Voltage Waveforms

PACKAGING INFORMATION

Orderable Device	Status ⁽¹⁾	Package Type	Package Drawing	Pins	Package Qty	Eco Plan ⁽²⁾	Lead/Ball Finish	MSL Peak Temp ⁽³⁾
MC3487D	ACTIVE	SOIC	D	16	40	Green (RoHS & no Sb/Br)	CU NIPDAU	Level-1-260C-UNLIM
MC3487DE4	ACTIVE	SOIC	D	16	40	Green (RoHS & no Sb/Br)	CU NIPDAU	Level-1-260C-UNLIM
MC3487DR	ACTIVE	SOIC	D	16	2500	Green (RoHS & no Sb/Br)	CU NIPDAU	Level-1-260C-UNLIM
MC3487DRE4	ACTIVE	SOIC	D	16	2500	Green (RoHS & no Sb/Br)	CU NIPDAU	Level-1-260C-UNLIM
MC3487J	OBSOLETE	CDIP	J	16		TBD	Call TI	Call TI
MC3487N	ACTIVE	PDIP	N	16	25	Pb-Free (RoHS)	CU NIPDAU	N / A for Pkg Type
MC3487NE4	ACTIVE	PDIP	N	16	25	Pb-Free (RoHS)	CU NIPDAU	N / A for Pkg Type
MC3487NSR	ACTIVE	SO	NS	16	2000	Green (RoHS & no Sb/Br)	CU NIPDAU	Level-1-260C-UNLIM
MC3487NSRE4	ACTIVE	SO	NS	16	2000	Green (RoHS & no Sb/Br)	CU NIPDAU	Level-1-260C-UNLIM

⁽¹⁾ The marketing status values are defined as follows:

ACTIVE: Product device recommended for new designs.

LIFEBUY: TI has announced that the device will be discontinued, and a lifetime-buy period is in effect.

NRND: Not recommended for new designs. Device is in production to support existing customers, but TI does not recommend using this part in a new design.

PREVIEW: Device has been announced but is not in production. Samples may or may not be available.

OBSOLETE: TI has discontinued the production of the device.

⁽²⁾ Eco Plan - The planned eco-friendly classification: Pb-Free (RoHS), Pb-Free (RoHS Exempt), or Green (RoHS & no Sb/Br) - please check <http://www.ti.com/productcontent> for the latest availability information and additional product content details.

TBD: The Pb-Free/Green conversion plan has not been defined.

Pb-Free (RoHS): TI's terms "Lead-Free" or "Pb-Free" mean semiconductor products that are compatible with the current RoHS requirements for all 6 substances, including the requirement that lead not exceed 0.1% by weight in homogeneous materials. Where designed to be soldered at high temperatures, TI Pb-Free products are suitable for use in specified lead-free processes.

Pb-Free (RoHS Exempt): This component has a RoHS exemption for either 1) lead-based flip-chip solder bumps used between the die and package, or 2) lead-based die adhesive used between the die and leadframe. The component is otherwise considered Pb-Free (RoHS compatible) as defined above.

Green (RoHS & no Sb/Br): TI defines "Green" to mean Pb-Free (RoHS compatible), and free of Bromine (Br) and Antimony (Sb) based flame retardants (Br or Sb do not exceed 0.1% by weight in homogeneous material)

⁽³⁾ MSL, Peak Temp. -- The Moisture Sensitivity Level rating according to the JEDEC industry standard classifications, and peak solder temperature.

Important Information and Disclaimer:The information provided on this page represents TI's knowledge and belief as of the date that it is provided. TI bases its knowledge and belief on information provided by third parties, and makes no representation or warranty as to the accuracy of such information. Efforts are underway to better integrate information from third parties. TI has taken and continues to take reasonable steps to provide representative and accurate information but may not have conducted destructive testing or chemical analysis on incoming materials and chemicals. TI and TI suppliers consider certain information to be proprietary, and thus CAS numbers and other limited information may not be available for release.

In no event shall TI's liability arising out of such information exceed the total purchase price of the TI part(s) at issue in this document sold by TI to Customer on an annual basis.

J (R-GDIP-T**)
14 LEADS SHOWN

CERAMIC DUAL IN-LINE PACKAGE



DIM \ PINS **	14	16	18	20
A	0.300 (7,62) BSC	0.300 (7,62) BSC	0.300 (7,62) BSC	0.300 (7,62) BSC
B MAX	0.785 (19,94)	.840 (21,34)	0.960 (24,38)	1.060 (26,92)
B MIN	—	—	—	—
C MAX	0.300 (7,62)	0.300 (7,62)	0.310 (7,87)	0.300 (7,62)
C MIN	0.245 (6,22)	0.245 (6,22)	0.220 (5,59)	0.245 (6,22)



4040083/F 03/03

- NOTES:
- All linear dimensions are in inches (millimeters).
 - This drawing is subject to change without notice.
 - This package is hermetically sealed with a ceramic lid using glass frit.
 - Index point is provided on cap for terminal identification only on press ceramic glass frit seal only.
 - Falls within MIL STD 1835 GDIP1-T14, GDIP1-T16, GDIP1-T18 and GDIP1-T20.

MECHANICAL DATA

N (R-PDIP-T**)

PLASTIC DUAL-IN-LINE PACKAGE

16 PINS SHOWN

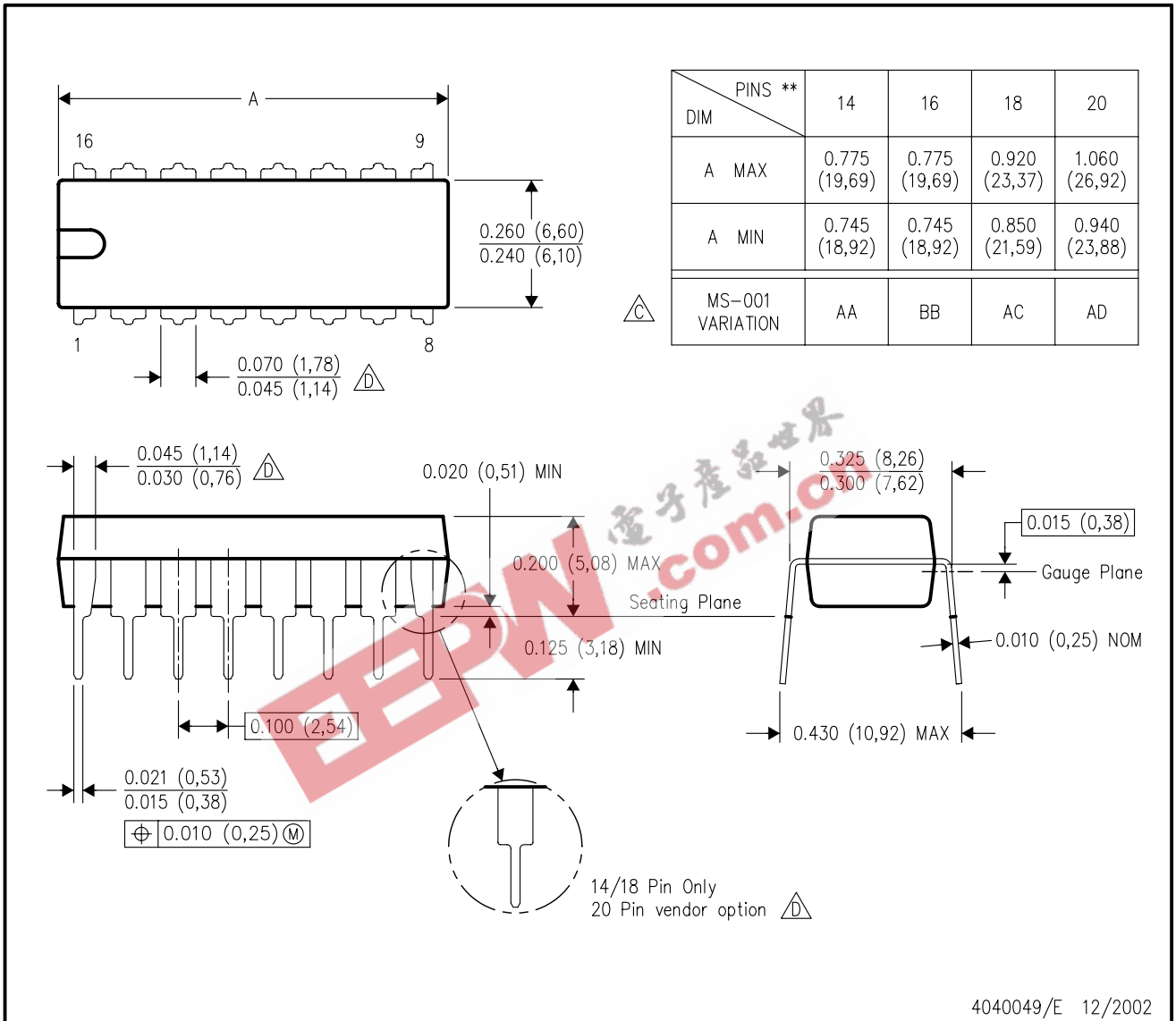

- NOTES:
- A. All linear dimensions are in inches (millimeters).
 - B. This drawing is subject to change without notice.
 - Falls within JEDEC MS-001, except 18 and 20 pin minimum body length (Dim A).
 - The 20 pin end lead shoulder width is a vendor option, either half or full width.

MECHANICAL DATA

D (R-PDSO-G16)

PLASTIC SMALL-OUTLINE PACKAGE

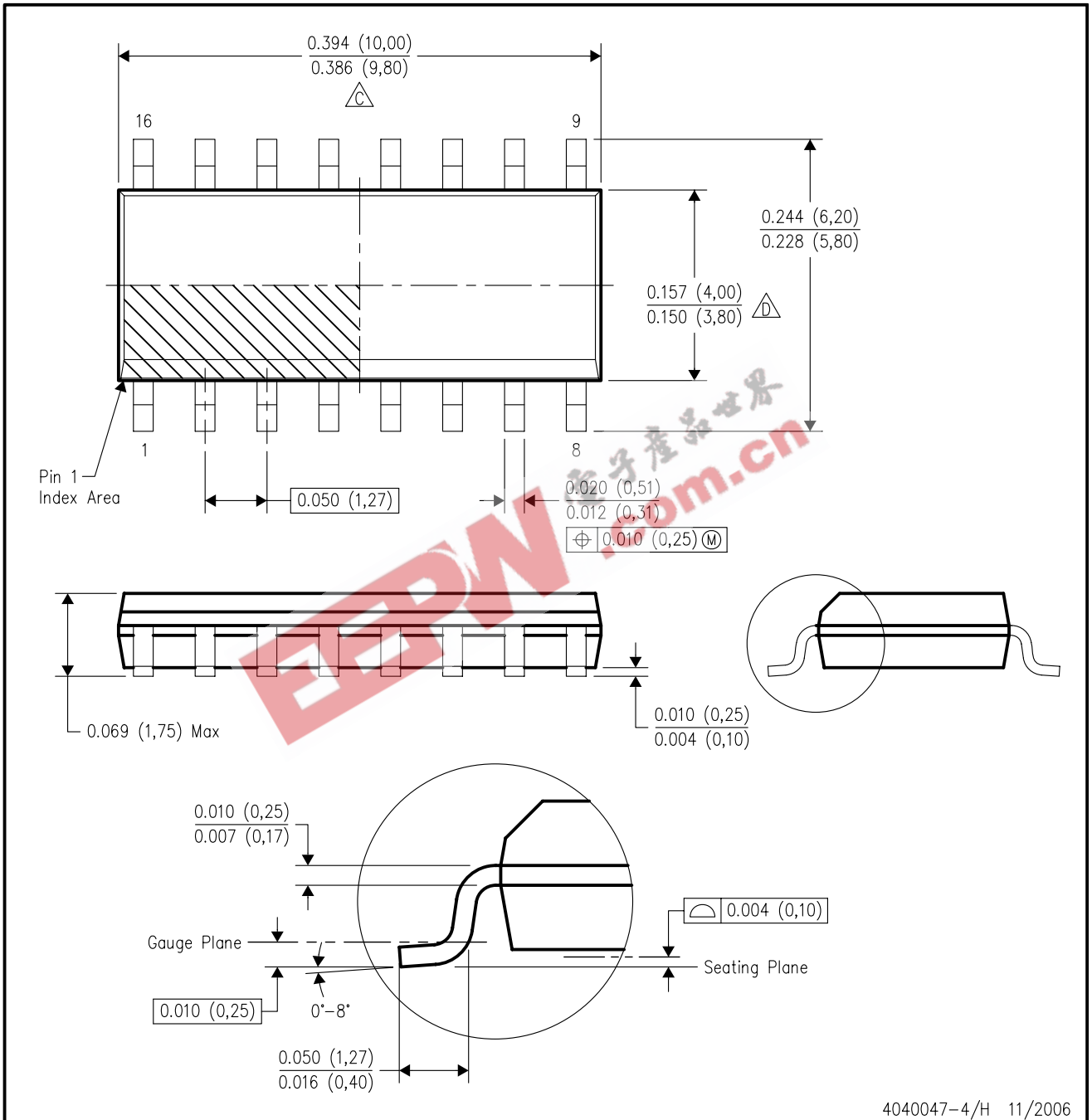

- NOTES:
- All linear dimensions are in inches (millimeters).
 - This drawing is subject to change without notice.
 - $\triangle C$ Body length does not include mold flash, protrusions, or gate burrs. Mold flash, protrusions, or gate burrs shall not exceed .006 (0,15) per end.
 - $\triangle D$ Body width does not include interlead flash. Interlead flash shall not exceed .017 (0,43) per side.
 - Reference JEDEC MS-012 variation AC.

MECHANICAL DATA

NS (R-PDSO-G)**

PLASTIC SMALL-OUTLINE PACKAGE

14-PINS SHOWN

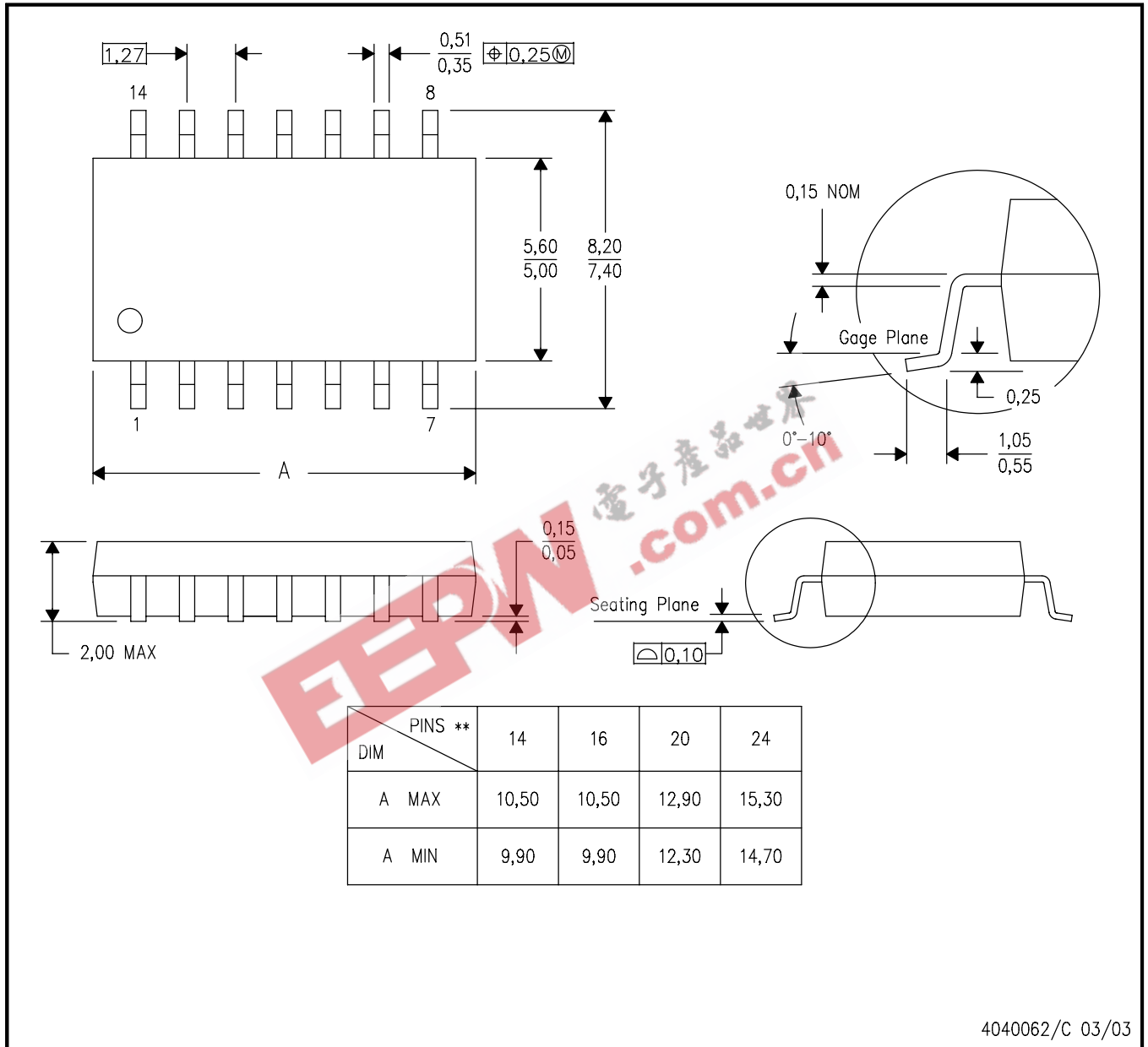

4040062/C 03/03

- NOTES:
- All linear dimensions are in millimeters.
 - This drawing is subject to change without notice.
 - Body dimensions do not include mold flash or protrusion, not to exceed 0,15.

IMPORTANT NOTICE

Texas Instruments Incorporated and its subsidiaries (TI) reserve the right to make corrections, modifications, enhancements, improvements, and other changes to its products and services at any time and to discontinue any product or service without notice. Customers should obtain the latest relevant information before placing orders and should verify that such information is current and complete. All products are sold subject to TI's terms and conditions of sale supplied at the time of order acknowledgment.

TI warrants performance of its hardware products to the specifications applicable at the time of sale in accordance with TI's standard warranty. Testing and other quality control techniques are used to the extent TI deems necessary to support this warranty. Except where mandated by government requirements, testing of all parameters of each product is not necessarily performed.

TI assumes no liability for applications assistance or customer product design. Customers are responsible for their products and applications using TI components. To minimize the risks associated with customer products and applications, customers should provide adequate design and operating safeguards.

TI does not warrant or represent that any license, either express or implied, is granted under any TI patent right, copyright, mask work right, or other TI intellectual property right relating to any combination, machine, or process in which TI products or services are used. Information published by TI regarding third-party products or services does not constitute a license from TI to use such products or services or a warranty or endorsement thereof. Use of such information may require a license from a third party under the patents or other intellectual property of the third party, or a license from TI under the patents or other intellectual property of TI.

Reproduction of information in TI data books or data sheets is permissible only if reproduction is without alteration and is accompanied by all associated warranties, conditions, limitations, and notices. Reproduction of this information with alteration is an unfair and deceptive business practice. TI is not responsible or liable for such altered documentation.

Resale of TI products or services with statements different from or beyond the parameters stated by TI for that product or service voids all express and any implied warranties for the associated TI product or service and is an unfair and deceptive business practice. TI is not responsible or liable for any such statements.

Following are URLs where you can obtain information on other Texas Instruments products and application solutions:

Products		Applications	
Amplifiers	amplifier.ti.com	Audio	www.ti.com/audio
Data Converters	dataconverter.ti.com	Automotive	www.ti.com/automotive
DSP	dsp.ti.com	Broadband	www.ti.com/broadband
Interface	interface.ti.com	Digital Control	www.ti.com/digitalcontrol
Logic	logic.ti.com	Military	www.ti.com/military
Power Mgmt	power.ti.com	Optical Networking	www.ti.com/opticalnetwork
Microcontrollers	microcontroller.ti.com	Security	www.ti.com/security
Low Power Wireless	www.ti.com/lpw	Telephony	www.ti.com/telephony
		Video & Imaging	www.ti.com/video
		Wireless	www.ti.com/wireless

Mailing Address: Texas Instruments
Post Office Box 655303 Dallas, Texas 75265