

MC3458, MC3358

Dual, Low Power Operational Amplifiers

Utilizing the circuit designs perfected for the quad operational amplifiers, these dual operational amplifiers feature: low power drain, a common mode input voltage range extending to ground/ V_{EE} , and Single Supply or Split Supply operation.

These amplifiers have several distinct advantages over standard operational amplifier types in single supply applications. They can operate at supply voltages as low as 3.0 V or as high as 36 V with quiescent currents about one-fifth of those associated with the MC1741C (on a per amplifier basis). The common mode input range includes the negative supply, thereby eliminating the necessity for external biasing components in many applications. The output voltage range also includes the negative power supply voltage.

- Short Circuit Protected Outputs
- True Differential Input Stage
- Single Supply Operation: 3.0 V to 36 V
- Low Input Bias Currents
- Internally Compensated
- Common Mode Range Extends to Negative Supply
- Class AB Output Stage for Minimum Crossover Distortion
- Single and Split Supply Operations Available
- Similar Performance to the Popular MC1458



ON Semiconductor™

<http://onsemi.com>

MARKING DIAGRAMS

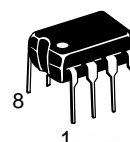

**PDIP-8
P1 SUFFIX
CASE 626**

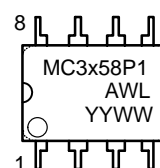

**SO-8
D SUFFIX
CASE 751**

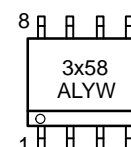

x = 3 or 4
A = Assembly Location
WL, L = Wafer Lot
YY, Y = Year
WW, W = Work Week

PIN CONNECTIONS

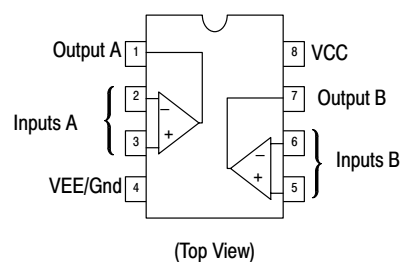

ORDERING INFORMATION

Device	Package	Shipping
MC3358D	SO-8	98 Units/Rail
MC3358DR2	SO-8	2500 Tape & Reel
MC3358P1	PDIP-8	50 Units/Rail
MC3458D	SO-8	98 Units/Rail
MC3458DR2	SO-8	2500 Tape & Reel
MC3458P1	PDIP-8	50 Units/Rail

MC3458, MC3358

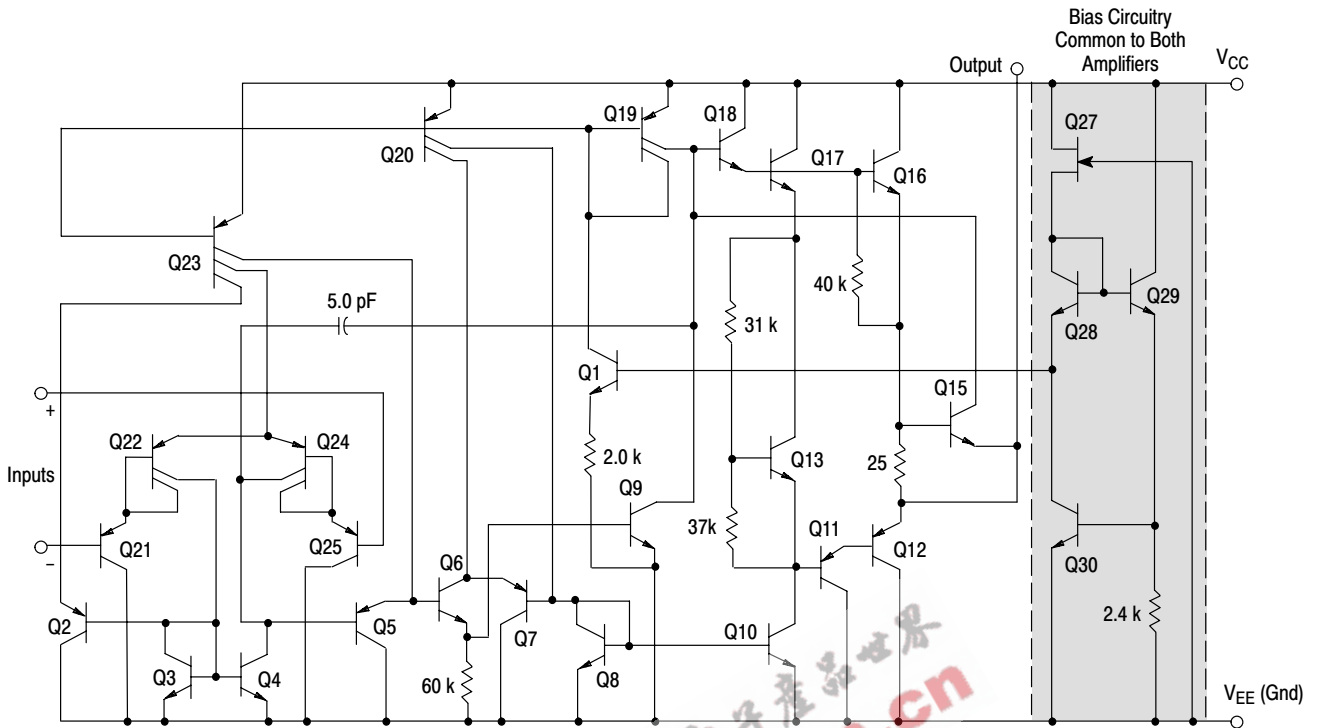

Figure 1. Representative Schematic Diagram
(1/2 of Circuit Shown)

MAXIMUM RATINGS

Rating	Symbol	Value	Unit
Power Supply Voltages			Vdc
Single Supply	V_{CC}	36	
Split Supplies	V_{CC}, V_{EE}	± 18	
Input Differential Voltage Range (Note 1.)	V_{IDR}	± 30	Vdc
Input Common Mode Voltage Range (Note 2.)	V_{ICR}	± 15	Vdc
Junction Temperature	T_J	150	$^{\circ}C$
Storage Temperature Range	T_{stg}	-55 to +125	$^{\circ}C$
Operating Ambient Temperature Range	T_A		$^{\circ}C$
MC3458		0 to +70	
MC3358		-40 to +85	

1. Split Power Supplies.

2. For supply voltages less than ± 18 V, the absolute maximum input voltage is equal to the supply voltage.

MC3458, MC3358

ELECTRICAL CHARACTERISTICS (For MC3458, $V_{CC} = +15\text{ V}$, $V_{EE} = -15\text{ V}$, $T_A = 25^\circ\text{C}$, unless otherwise noted.)
 (For MC3358, $V_{CC} = +14\text{ V}$, $V_{EE} = \text{Gnd}$, $T_A = 25^\circ\text{C}$, unless otherwise noted.)

Characteristic	Symbol	MC3458			MC3358			Unit
		Min	Typ	Max	Min	Typ	Max	
Input Offset Voltage $T_A = T_{\text{high}} \text{ to } T_{\text{low}}$ (Note 3.)	V_{IO}	–	2.0	10	–	2.0	8.0	mV
		–	–	12	–	–	10	
Input Offset Current $T_A = T_{\text{high}} \text{ to } T_{\text{low}}$	I_{IO}	–	30	50	–	30	75	nA
		–	–	200	–	–	250	
Large Signal Open Loop Voltage Gain $V_O = \pm 10\text{ V}$, $R_L = 2.0\text{ k}\Omega$, $T_A = T_{\text{high}} \text{ to } T_{\text{low}}$	A_{VOL}	20	200	–	20	200	–	V/mV
		15	–	–	15	–	–	
Input Bias Current $T_A = T_{\text{high}} \text{ to } T_{\text{low}}$	I_{IB}	–	–200	–500	–	–200	–500	nA
		–	–	–800	–	–	–1000	
Output Impedance, $f = 20\text{ Hz}$	Z_O	–	75	–	–	75	–	Ω
Input Impedance, $f = 20\text{ Hz}$	Z_I	0.3	1.0	–	0.3	1.0	–	M Ω
Output Voltage Range $R_L = 10\text{ k}\Omega$ $R_L = 2.0\text{ k}\Omega$ $R_L = 2.0\text{ k}\Omega$, $T_A = T_{\text{high}} \text{ to } T_{\text{low}}$	V_{OR}	± 12	± 13.5	–	12	12.5	–	V
		± 10	± 13	–	10	12	–	
		± 10	–	–	10	–	–	
Input Common Mode Voltage Range	V_{ICR}	+13 – V_{EE}	+13.5 – V_{EE}	–	+13 – V_{EE}	+13.5 – V_{EE}	–	V
Common Mode Rejection Ratio, $R_S \leq 10\text{ k}\Omega$	CMR	70	90	–	70	90	–	dB
Power Supply Current ($V_O = 0$) $R_L = \infty$	I_{CC}, I_{EE}	–	1.6	3.7	–	1.6	3.7	mA
Individual Output Short Circuit Current (Note 4.)	I_{SC}	± 10	± 20	± 45	± 10	± 30	± 45	mA
Positive Power Supply Rejection Ratio	PSRR+	–	30	150	–	30	150	$\mu\text{V/V}$
Negative Power Supply Rejection Ratio	PSRR–	–	30	150	–	–	–	$\mu\text{V/V}$
Average Temperature Coefficient of Input Offset Current, $T_A = T_{\text{high}} \text{ to } T_{\text{low}}$	$\Delta I_{IO}/\Delta T$	–	50	–	–	50	–	$\text{pA}/^\circ\text{C}$
Average Temperature Coefficient of Input Offset Current, $T_A = T_{\text{high}} \text{ to } T_{\text{low}}$	$\Delta V_{IO}/\Delta T$	–	10	–	–	10	–	$\mu\text{V}/^\circ\text{C}$
Power Bandwidth $A_V = 1$, $R_L = 2.0\text{ k}\Omega$, $V_O = 20\text{ V}_{pp}$, THD = 5%	BWp	–	9.0	–	–	9.0	–	kHz
Small Signal Bandwidth $A_V = 1$, $R_L = 10\text{ k}\Omega$, $V_O = 50\text{ mV}$	BW	–	1.0	–	–	1.0	–	MHz
Slew Rate $A_V = 1$, $V_I = -10\text{ V to } +10\text{ V}$	SR	–	0.6	–	–	0.6	–	V/ μs
Rise Time $A_V = 1$, $R_L = 10\text{ k}\Omega$, $V_O = 50\text{ mV}$	t_{TLH}	–	0.35	–	–	0.35	–	μs
Fall Time $A_V = 1$, $R_L = 10\text{ k}\Omega$, $V_O = 50\text{ mV}$	t_{THL}	–	0.35	–	–	0.35	–	μs
Overshoot $A_V = 1$, $R_L = 10\text{ k}\Omega$, $V_O = 50\text{ mV}$	os	–	20	–	–	20	–	%
Phase Margin $A_V = 1$, $R_L = 2.0\text{ k}\Omega$, $C_L = 200\text{ pF}$	ϕ_m	–	60	–	–	60	–	Degrees
Crossover Distortion ($V_{in} = 30\text{ mV}_{pp}$, $V_{out} = 2.0\text{ V}_{pp}$, $f = 10\text{ kHz}$)	–	–	1.0	–	–	1.0	–	%

3. MC3358: $T_{\text{low}} = -40^\circ\text{C}$, $T_{\text{high}} = +85^\circ\text{C}$

MC3458: $T_{\text{low}} = 0^\circ\text{C}$, $T_{\text{high}} = +70^\circ\text{C}$

4. Not to exceed maximum package power dissipation.

MC3458, MC3358

ELECTRICAL CHARACTERISTICS ($V_{CC} = 5.0\text{ V}$, $V_{EE} = \text{Gnd}$, $T_A = 25^\circ\text{C}$, unless otherwise noted.)

Characteristic	Symbol	MC3458			MC3358			Unit
		Min	Typ	Max	Min	Typ	Max	
Input Offset Voltage	V_{IO}	–	2.0	5.0	–	2.0	10	mV
Input Offset Current	I_{IO}	–	30	50	–	–	75	nA
Input Bias Current	I_{IB}	–	–200	–500	–	–	–500	nA
Large Signal Open Loop Voltage Gain $R_L = 2.0\text{ k}\Omega$,	A_{VOL}	20	200	–	20	200	–	V/mV
Power Supply Rejection Ratio	PSRR	–	–	150	–	–	150	$\mu\text{V/V}$
Output Voltage Range (Note 5.) $R_L = 10\text{ k}\Omega$, $V_{CC} = 5.0\text{ V}$ $R_L = 10\text{ k}\Omega$, $5.0\text{ V} \leq V_{CC} \leq 30\text{ V}$	V_{OR}	3.3 –	3.5 V_{CC} –1.7	– –	3.3 –	3.5 V_{CC} –1.7	– –	V_{pp}
Power Supply Current	I_{CC}	–	2.5	7.0	–	2.5	4.0	mA
Channel Separation $f = 1.0\text{ kHz to } 20\text{ kHz}$ (Input Referenced)	CS	–	–120	–	–	–120	–	dB

5. Output will swing to ground with a 10 k Ω pull down resistor.

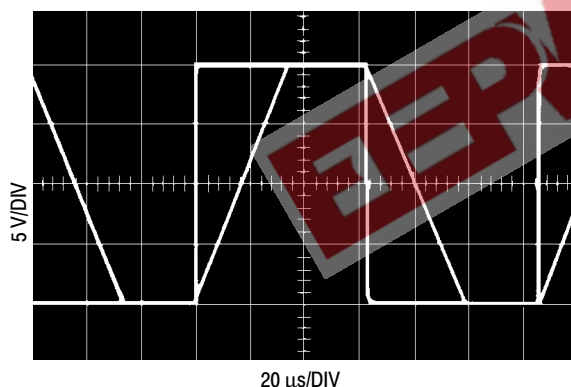

Figure 2. Inverter Pulse Response

CIRCUIT DESCRIPTION

The MC3458/3358 is made using two internally compensated, two-stage operational amplifiers. The first stage of each consists of differential input devices Q24 and Q22 with input buffer transistors Q25 and Q21 and the differential to single ended converter Q3 and Q4. The first

stage performs not only the first stage gain function but also performs the level shifting and transconductance reduction functions. By reducing the transconductance, a smaller compensation capacitor (only 5.0 pF) can be employed, thus saving chip area. The transconductance reduction is accomplished by splitting the collectors of Q24 and Q22. Another feature of this input stage is that the input Common Mode range can include the negative supply or ground, in single supply operation, without saturating either the input devices or the differential to single-ended converter. The second stage consists of a standard current source load amplifier stage.

The output stage is unique because it allows the output to swing to ground in single supply operation and yet does not exhibit any crossover distortion in split supply operation. This is possible because Class AB operation is utilized.

Each amplifier is biased from an internal voltage regulator which has a low temperature coefficient thus giving each amplifier good temperature characteristics as well as excellent power supply rejection.

MC3458, MC3358

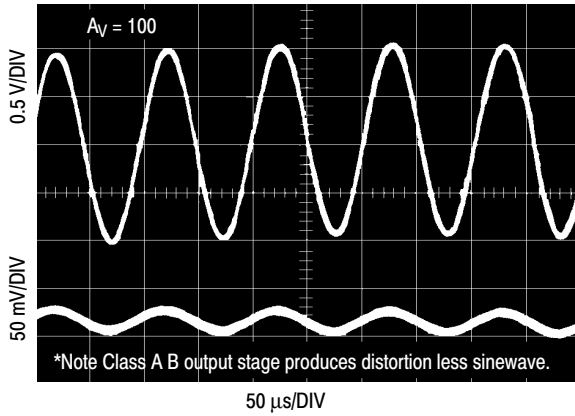

Figure 3. Sine Wave Response

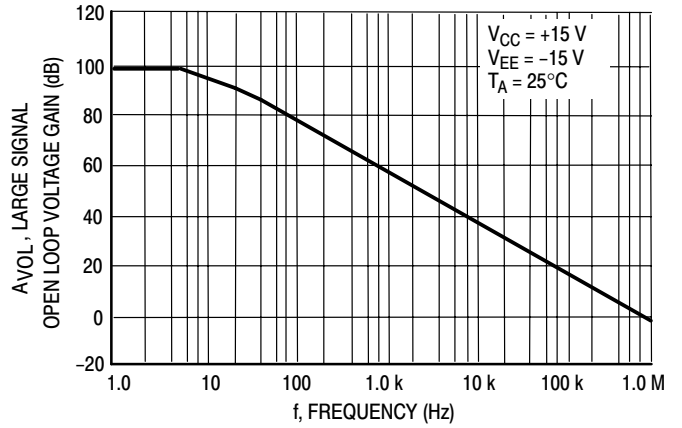

Figure 4. Open Loop Frequency Response

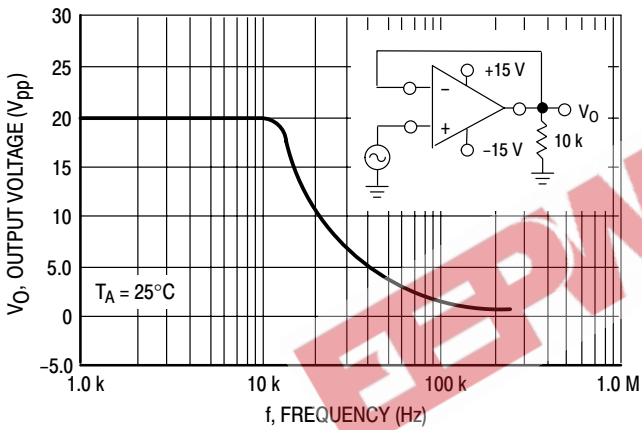

Figure 5. Power Bandwidth

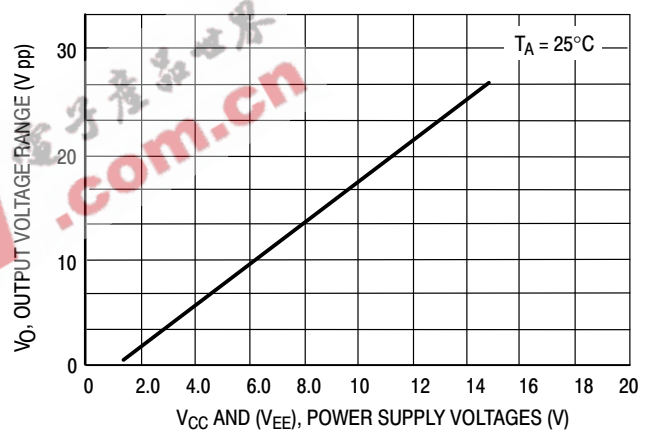

Figure 6. Output Swing versus Supply Voltage

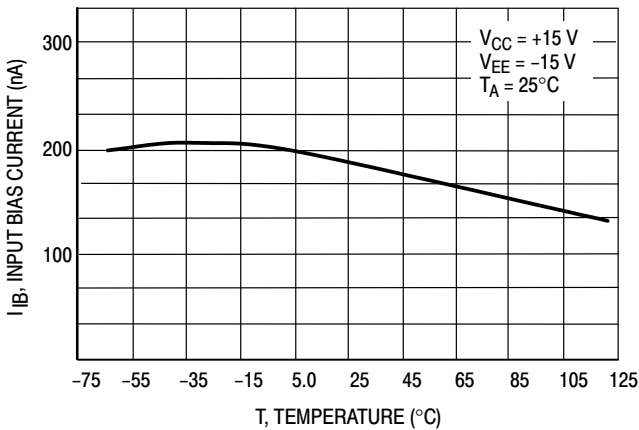

Figure 7. Input Bias Current versus Temperature

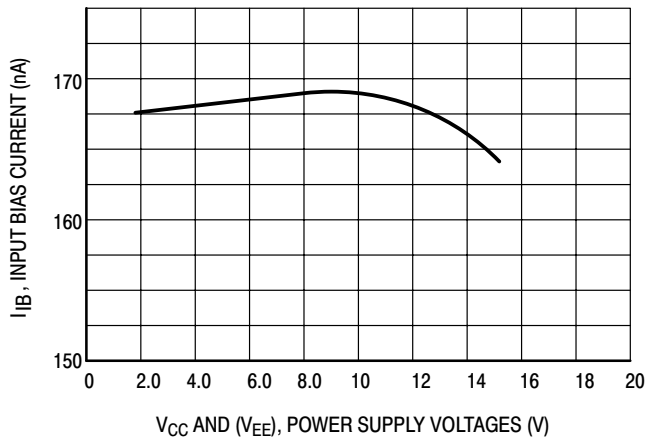

Figure 8. Input Bias Current versus Supply Voltage

MC3458, MC3358

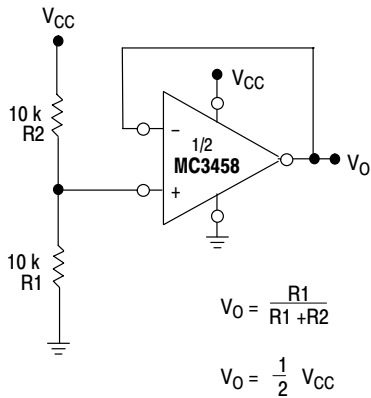

Figure 9. Voltage Reference

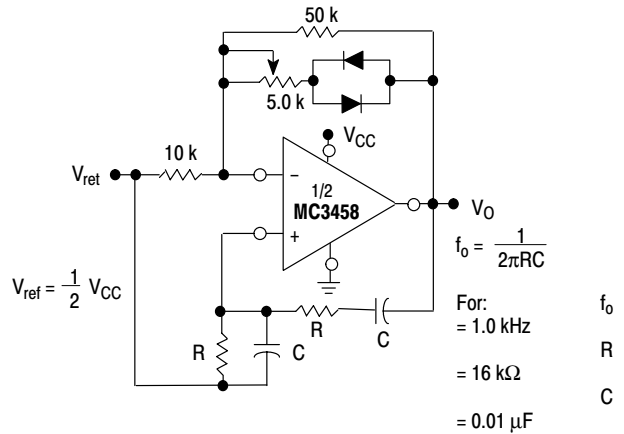

Figure 10. Wien Bridge Oscillator

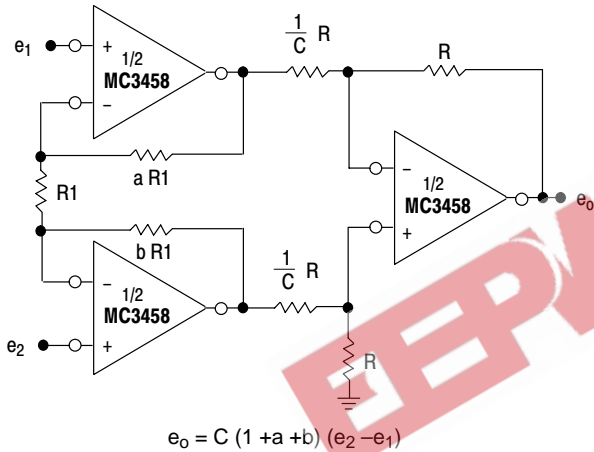

Figure 11. High Impedance Differential Amplifier

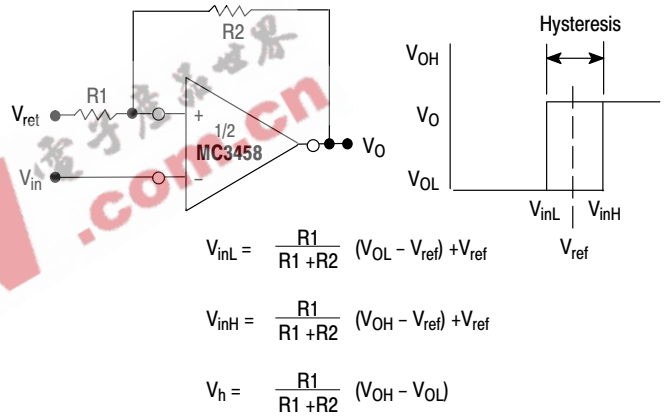

Figure 12. Comparator with Hysteresis

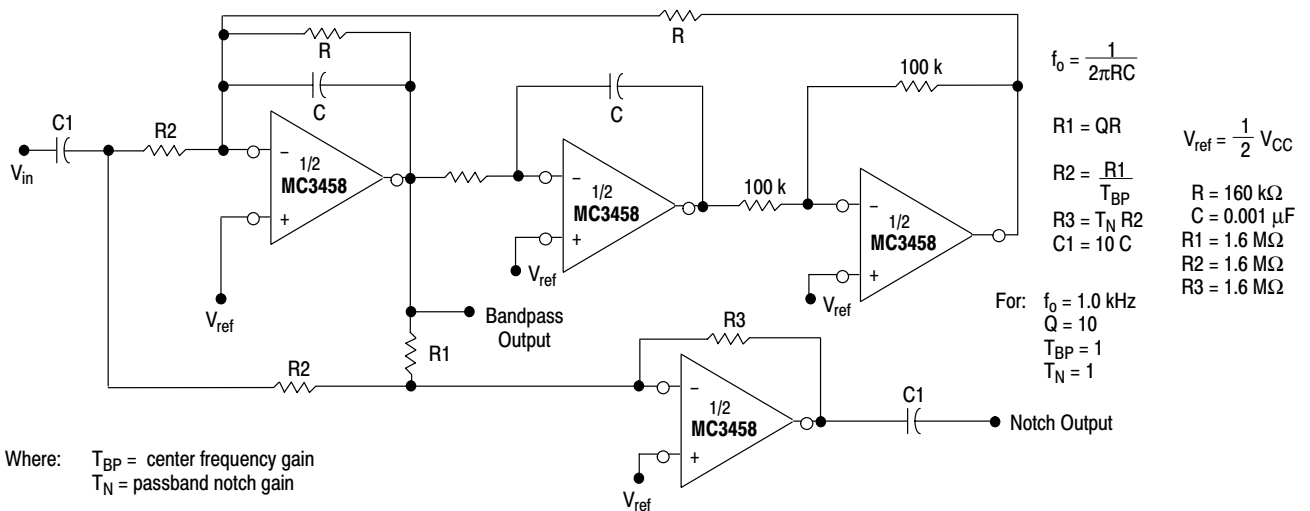

Figure 13. Bi-Quad Filter

MC3458, MC3358

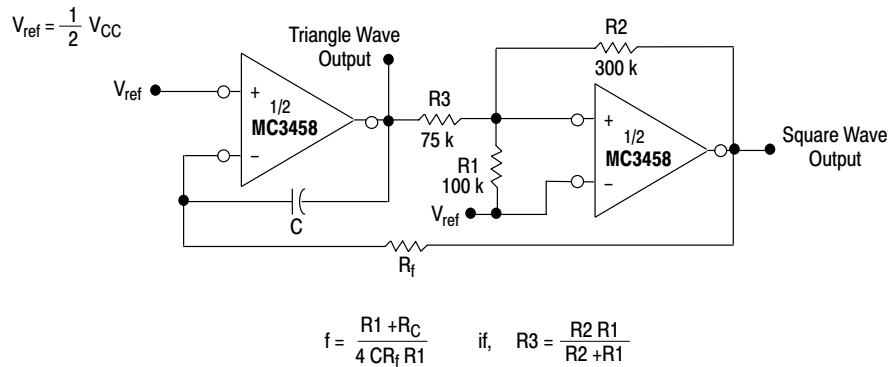
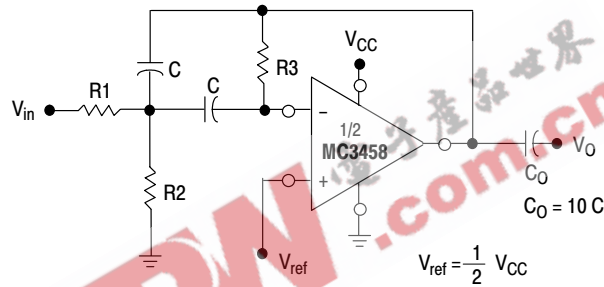

Figure 14. Function Generator



Given: f_0 = center frequency
 $A(f_0)$ = gain at center frequency

Choose value f_0 , C.

$$\text{Then: } R3 = \frac{Q}{\pi f_0 C} \quad R1 = \frac{R3}{2 A(f_0)} \quad R2 = \frac{R1 R5}{4Q^2 R1 - R3}$$

For less than 10% error from operational amplifier $\frac{Q_0 f_0}{BW} < 0.1$

where, f_0 and BW are expressed in Hz.

If source impedance varies, filter may be preceded with voltage follower buffer to stabilize filter parameters.

Figure 15. Multiple Feedback Bandpass Filter

MC3458, MC3358

PACKAGE DIMENSIONS

PDIP-8
P1 SUFFIX
CASE 626-05
ISSUE L

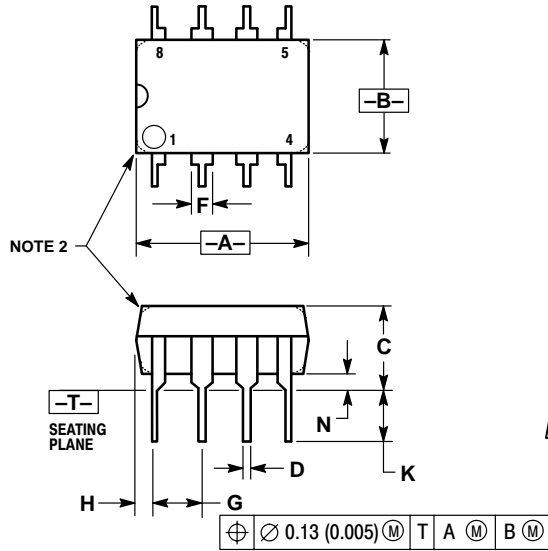

NOTES:

1. DIMENSION L TO CENTER OF LEAD WHEN FORMED PARALLEL.
2. PACKAGE CONTOUR OPTIONAL (ROUND OR SQUARE CORNERS).
3. DIMENSIONING AND TOLERANCING PER ANSI Y14.5M, 1982.

DIM	MILLIMETERS		INCHES	
	MIN	MAX	MIN	MAX
A	9.40	10.16	0.370	0.400
B	6.10	6.60	0.240	0.260
C	3.94	4.45	0.155	0.175
D	0.38	0.51	0.015	0.020
F	1.02	1.78	0.040	0.070
G	2.54 BSC		0.100 BSC	
H	0.76	1.27	0.030	0.050
J	0.20	0.30	0.008	0.012
K	2.92	3.43	0.115	0.135
L	7.62 BSC		0.300 BSC	
M	---	10 [°]	---	10 [°]
N	0.76	1.01	0.030	0.040

SO-8
D SUFFIX
CASE 751-07
ISSUE W

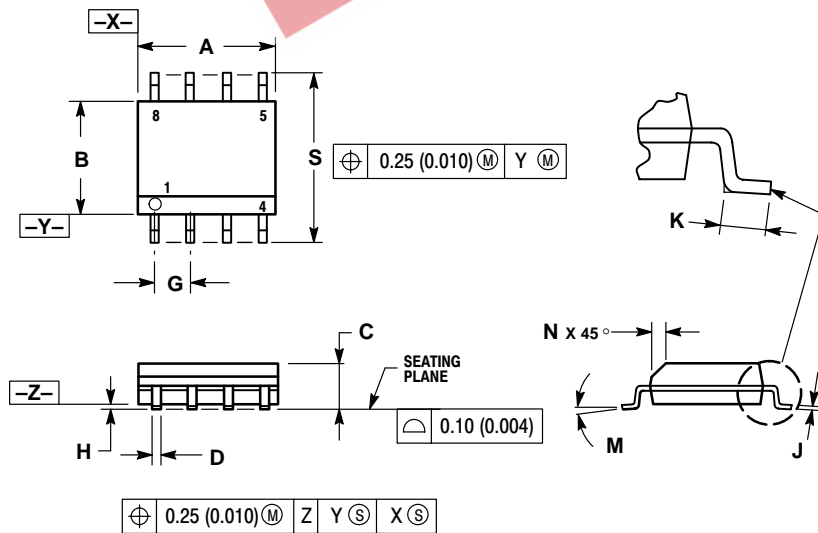

NOTES:

1. DIMENSIONING AND TOLERANCING PER ANSI Y14.5M, 1982.
2. CONTROLLING DIMENSION: MILLIMETER.
3. DIMENSION A AND B DO NOT INCLUDE MOLD PROTRUSION.
4. MAXIMUM MOLD PROTRUSION 0.15 (0.006) PER SIDE.
5. DIMENSION D DOES NOT INCLUDE DAMBAR PROTRUSION. ALLOWABLE DAMBAR PROTRUSION SHALL BE 0.127 (0.005) TOTAL IN EXCESS OF THE D DIMENSION AT MAXIMUM MATERIAL CONDITION.

DIM	MILLIMETERS		INCHES	
	MIN	MAX	MIN	MAX
A	4.80	5.00	0.189	0.197
B	3.80	4.00	0.150	0.157
C	1.35	1.75	0.053	0.069
D	0.33	0.51	0.013	0.020
G	1.27 BSC		0.050 BSC	
H	0.10	0.25	0.004	0.010
J	0.19	0.25	0.007	0.010
K	0.40	1.27	0.016	0.050
M	0 [°]	8 [°]	0 [°]	8 [°]
N	0.25	0.50	0.010	0.020
S	5.80	6.20	0.228	0.244

MC3458, MC3358

Notes

EEPW 电子产品世界
.com.cn

MC3458, MC3358

Notes

EEPW 电子产品世界
.com.cn

MC3458, MC3358

Notes

EEPW 电子产品世界
.com.cn

MC3458, MC3358

ON Semiconductor and  are trademarks of Semiconductor Components Industries, LLC (SCILLC). SCILLC reserves the right to make changes without further notice to any products herein. SCILLC makes no warranty, representation or guarantee regarding the suitability of its products for any particular purpose, nor does SCILLC assume any liability arising out of the application or use of any product or circuit, and specifically disclaims any and all liability, including without limitation special, consequential or incidental damages. "Typical" parameters which may be provided in SCILLC data sheets and/or specifications can and do vary in different applications and actual performance may vary over time. All operating parameters, including "Typicals" must be validated for each customer application by customer's technical experts. SCILLC does not convey any license under its patent rights nor the rights of others. SCILLC products are not designed, intended, or authorized for use as components in systems intended for surgical implant into the body, or other applications intended to support or sustain life, or for any other application in which the failure of the SCILLC product could create a situation where personal injury or death may occur. Should Buyer purchase or use SCILLC products for any such unintended or unauthorized application, Buyer shall indemnify and hold SCILLC and its officers, employees, subsidiaries, affiliates, and distributors harmless against all claims, costs, damages, and expenses, and reasonable attorney fees arising out of, directly or indirectly, any claim of personal injury or death associated with such unintended or unauthorized use, even if such claim alleges that SCILLC was negligent regarding the design or manufacture of the part. SCILLC is an Equal Opportunity/Affirmative Action Employer.

PUBLICATION ORDERING INFORMATION

NORTH AMERICA Literature Fulfillment:

Literature Distribution Center for ON Semiconductor
P.O. Box 5163, Denver, Colorado 80217 USA
Phone: 303-675-2175 or 800-344-3860 Toll Free USA/Canada
Fax: 303-675-2176 or 800-344-3867 Toll Free USA/Canada
Email: ONlit@hibbertco.com
Fax Response Line: 303-675-2167 or 800-344-3810 Toll Free USA/Canada

N. American Technical Support: 800-282-9855 Toll Free USA/Canada

EUROPE: LDC for ON Semiconductor – European Support

German Phone: (+1) 303-308-7140 (Mon–Fri 2:30pm to 7:00pm CET)
Email: ONlit-german@hibbertco.com
French Phone: (+1) 303-308-7141 (Mon–Fri 2:00pm to 7:00pm CET)
Email: ONlit-french@hibbertco.com
English Phone: (+1) 303-308-7142 (Mon–Fri 12:00pm to 5:00pm GMT)
Email: ONlit@hibbertco.com

EUROPEAN TOLL-FREE ACCESS*: 00-800-4422-3781

*Available from Germany, France, Italy, UK, Ireland

CENTRAL/SOUTH AMERICA:

Spanish Phone: 303-308-7143 (Mon–Fri 8:00am to 5:00pm MST)
Email: ONlit-spanish@hibbertco.com
Toll-Free from Mexico: Dial 01-800-288-2872 for Access –
then Dial 866-297-9322

ASIA/PACIFIC: LDC for ON Semiconductor – Asia Support

Phone: 303-675-2121 (Tue–Fri 9:00am to 1:00pm, Hong Kong Time)
Toll Free from Hong Kong & Singapore:
001-800-4422-3781
Email: ONlit-asia@hibbertco.com

JAPAN: ON Semiconductor, Japan Customer Focus Center 4-32-1 Nishi-Gotanda, Shinagawa-ku, Tokyo, Japan 141-0031

Phone: 81-3-5740-2700
Email: r14525@onsemi.com

ON Semiconductor Website: <http://onsemi.com>

For additional information, please contact your local
Sales Representative.

This datasheet has been download from:

www.datasheetcatalog.com

Datasheets for electronics components.

EEPW 电子產品世界
.com.cn