



MOTOROLA

Quad Low Power Operational Amplifiers

The MC3403 is a low cost, quad operational amplifier with true differential inputs. The device has electrical characteristics similar to the popular MC1741C. However, the MC3403 has several distinct advantages over standard operational amplifier types in single supply applications. The quad amplifier can operate at supply voltages as low as 3.0 V or as high as 36 V with quiescent currents about one third of those associated with the MC1741C (on a per amplifier basis). The common mode input range includes the negative supply, thereby eliminating the necessity for external biasing components in many applications. The output voltage range also includes the negative power supply voltage.

- Short Circuit Protected Outputs
- Class AB Output Stage for Minimal Crossover Distortion
- True Differential Input Stage
- Single Supply Operation: 3.0 V to 36 V
- Split Supply Operation: ± 1.5 V to ± 18 V
- Low Input Bias Currents: 500 nA Max
- Four Amplifiers Per Package
- Internally Compensated
- Similar Performance to Popular MC1741C
- Industry Standard Pinouts
- ESD Diodes Added for Increased Ruggedness

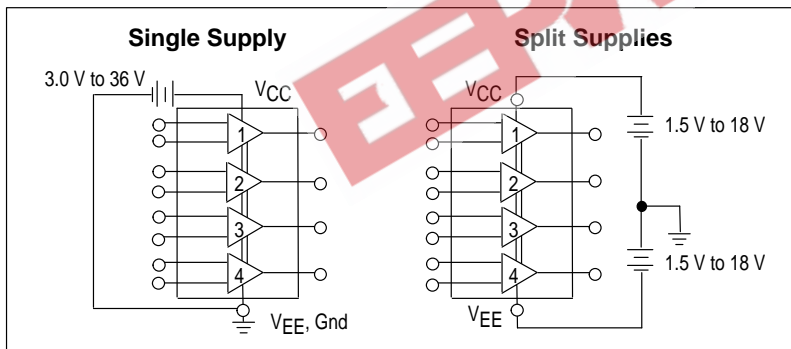

MAXIMUM RATINGS

Rating	Symbol	Value	Unit
Power Supply Voltages			
Single Supply	V_{CC}	36	Vdc
Split Supplies	V_{CC}, V_{EE}	± 18	
Input Differential Voltage Range (Note 1)	V_{IDR}	± 36	Vdc
Input Common Mode Voltage Range (Notes 1, 2)	V_{ICR}	± 18	Vdc
Storage Temperature Range	T_{stg}	-55 to +125	$^{\circ}C$
Operating Ambient Temperature Range	T_A	-40 to +85	$^{\circ}C$
MC3303		0 to +70	
MC3403			
Junction Temperature	T_J	150	$^{\circ}C$

NOTES: 1. Split power supplies.
 2. For supply voltages less than ± 18 V, the absolute maximum input voltage is equal to the supply voltage.

Order this document by MC3403/D

MC3403 MC3303

QUAD DIFFERENTIAL INPUT OPERATIONAL AMPLIFIERS

SEMICONDUCTOR TECHNICAL DATA

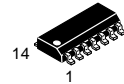

D SUFFIX
PLASTIC PACKAGE
CASE 751A
(SO-14)

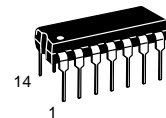

P SUFFIX
PLASTIC PACKAGE
CASE 646

PIN CONNECTIONS

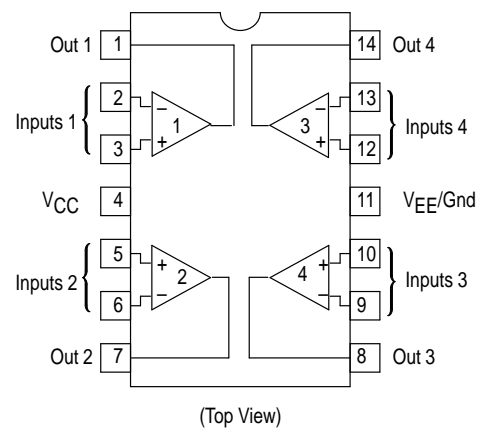

ORDERING INFORMATION

Device	Operating Temperature Range	Package
MC3303D MC3303P	$T_A = -40^{\circ}$ to $+85^{\circ}C$	SO-14 Plastic DIP
MC3403D MC3403P	$T_A = 0^{\circ}$ to $+70^{\circ}C$	SO-14 Plastic DIP

MC3403 MC3303

ELECTRICAL CHARACTERISTICS ($V_{CC} = +15\text{ V}$, $V_{EE} = -15\text{ V}$ for MC3403; $V_{CC} = +14\text{ V}$, $V_{EE} = \text{Gnd}$ for MC3303
 $T_A = 25^\circ\text{C}$, unless otherwise noted.)

Characteristic	Symbol	MC3403			MC3303			Unit
		Min	Typ	Max	Min	Typ	Max	
Input Offset Voltage $T_A = T_{\text{high}}$ to T_{low} (Note 1)	V_{IO}	–	2.0	10	–	2.0	8.0	mV
Input Offset Current $T_A = T_{\text{high}}$ to T_{low}	I_{IO}	–	30	50	–	30	75	nA
Large Signal Open Loop Voltage Gain $V_O = \pm 10\text{ V}$, $R_L = 2.0\text{ k}\Omega$ $T_A = T_{\text{high}}$ to T_{low}	A_{VOL}	20	200	–	20	200	–	V/mV
Input Bias Current $T_A = T_{\text{high}}$ to T_{low}	I_{IB}	–	–200	–500	–	–200	–500	nA
Output Impedance $f = 20\text{ Hz}$	z_o	–	75	–	–	75	–	Ω
Input Impedance $f = 20\text{ Hz}$	z_i	0.3	1.0	–	0.3	1.0	–	M Ω
Output Voltage Range $R_L = 10\text{ k}\Omega$ $R_L = 2.0\text{ k}\Omega$ $R_L = 2.0\text{ k}\Omega$, $T_A = T_{\text{high}}$ to T_{low}	V_O	± 12	± 13.5	–	12	12.5	–	V
Input Common Mode Voltage Range	V_{ICR}	+13 V – V_{EE}	+13 V – V_{EE}	–	+12 V – V_{EE}	+12.5 V – V_{EE}	–	V
Common Mode Rejection $R_S \leq 10\text{ k}\Omega$	CMR	70	90	–	70	90	–	dB
Power Supply Current ($V_O = 0$) $R_L = \infty$	I_{CC}, I_{EE}	–	2.8	7.0	–	2.8	7.0	mA
Individual Output Short-Circuit Current (Note 2)	I_{SC}	± 10	± 20	± 45	± 10	± 30	± 45	mA
Positive Power Supply Rejection Ratio	PSRR+	–	30	150	–	30	150	$\mu\text{V/V}$
Negative Power Supply Rejection Ratio	PSRR–	–	30	150	–	30	150	$\mu\text{V/V}$
Average Temperature Coefficient of Input Offset Current $T_A = T_{\text{high}}$ to T_{low}	$\Delta I_{IO}/\Delta T$	–	50	–	–	50	–	$\text{pA}/^\circ\text{C}$
Average Temperature Coefficient of Input Offset Voltage $T_A = T_{\text{high}}$ to T_{low}	$\Delta V_{IO}/\Delta T$	–	10	–	–	10	–	$\mu\text{V}/^\circ\text{C}$
Power Bandwidth $A_V = 1$, $R_L = 10\text{ k}\Omega$, $V_O = 20\text{ V(p-p)}$, THD = 5%	BWp	–	9.0	–	–	9.0	–	kHz
Small-Signal Bandwidth $A_V = 1$, $R_L = 10\text{ k}\Omega$, $V_O = 50\text{ mV}$	BW	–	1.0	–	–	1.0	–	MHz
Slew Rate $A_V = 1$, $V_i = -10\text{ V}$ to $+10\text{ V}$	SR	–	0.6	–	–	0.6	–	V/ μs
Rise Time $A_V = 1$, $R_L = 10\text{ k}\Omega$, $V_O = 50\text{ mV}$	t_{TLH}	–	0.35	–	–	0.35	–	μs
Fall Time $A_V = 1$, $R_L = 10\text{ k}\Omega$, $V_O = 50\text{ mV}$	t_{TLH}	–	0.35	–	–	0.35	–	μs
Overshoot $A_V = 1$, $R_L = 10\text{ k}\Omega$, $V_O = 50\text{ mV}$	os	–	20	–	–	20	–	%
Phase Margin $A_V = 1$, $R_L = 2.0\text{ k}\Omega$, $V_O = 200\text{ pF}$	ϕ_m	–	60	–	–	60	–	Degrees
Crossover Distortion ($V_{in} = 30\text{ mVpp}$, $V_{out} = 2.0\text{ Vpp}$, $f = 10\text{ kHz}$)	–	–	1.0	–	–	1.0	–	%

NOTES: 1. $T_{\text{high}} = +70^\circ\text{C}$ for MC3403, $+85^\circ\text{C}$ for MC3303
 $T_{\text{low}} = 0^\circ\text{C}$ for MC3403, -40°C for MC3303
 2. Not to exceed maximum package power dissipation.

MC3403 MC3303

ELECTRICAL CHARACTERISTICS ($V_{CC} = 5.0\text{ V}$, $V_{EE} = \text{Gnd}$, $T_A = 25^\circ\text{C}$, unless otherwise noted.)

Characteristic	Symbol	MC3403			MC3303			Unit
		Min	Typ	Max	Min	Typ	Max	
Input Offset Voltage	V_{IO}	–	2.0	10	–	–	10	mV
Input Offset Current	I_{IO}	–	30	50	–	–	75	nA
Input Bias Current	I_{IB}	–	–200	–500	–	–	–500	nA
Large Signal Open Loop Voltage Gain $R_L = 2.0\text{ k}\Omega$	A_{VOL}	10	200	–	10	200	–	V/mV
Power Supply Rejection Ratio	PSRR	–	–	150	–	–	150	$\mu\text{V/V}$
Output Voltage Range (Note 3) $R_L = 10\text{ k}\Omega$, $V_{CC} = 5.0\text{ V}$ $R_L = 10\text{ k}\Omega$, $5.0 \leq V_{CC} \leq 30\text{ V}$	V_{OR}	3.3 $V_{CC}-2.0$	3.5 $V_{CC}-1.7$	– –	3.3 $V_{CC}-2.0$	3.5 $V_{CC}-1.7$	– –	V_{pp}
Power Supply Current	I_{CC}	–	2.5	7.0	–	2.5	7.0	mA
Channel Separation $f = 1.0\text{ kHz to }20\text{ kHz}$ (Input Referenced)	CS	–	–120	–	–	–120	–	dB

NOTES: 3. Output will swing to ground with a 10 k Ω pull down resistor.

Representative Schematic Diagram

(1/4 of Circuit Shown)

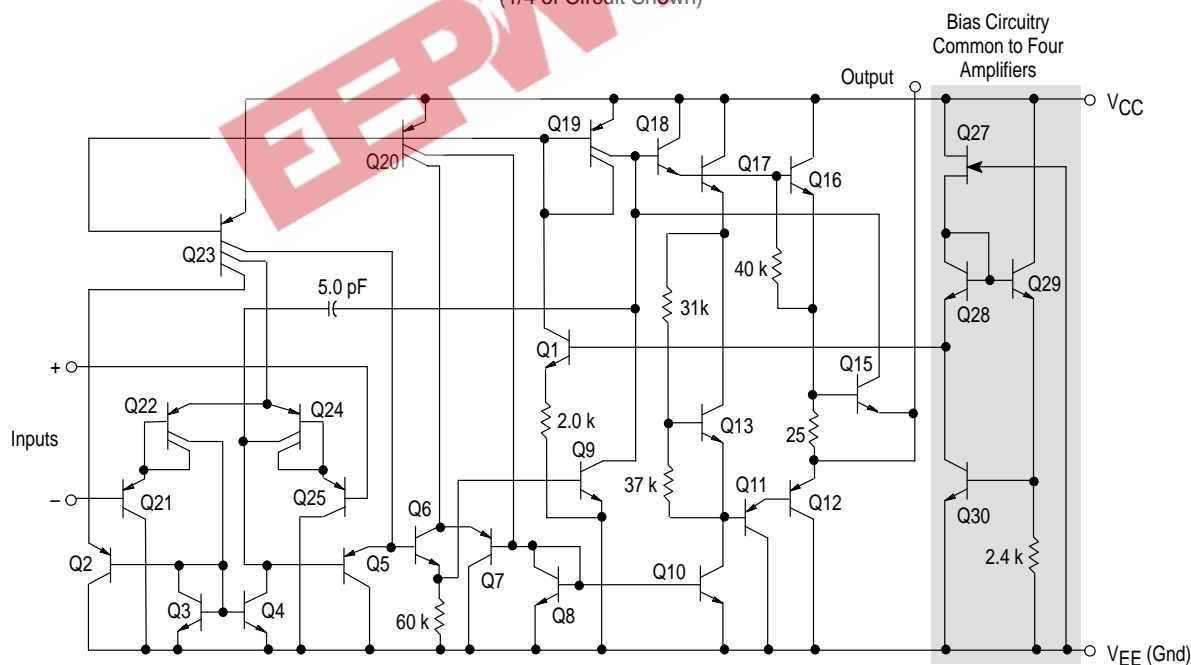

MC3403 MC3303

CIRCUIT DESCRIPTION

Inverter Pulse Response

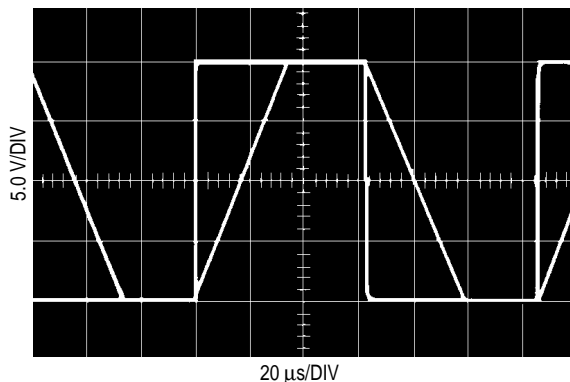

The MC3403/3303 is made using four internally compensated, two-stage operational amplifiers. The first stage of each consists of differential input device Q24 and Q22 with input buffer transistors Q25 and Q21 and the differential to single ended converter Q3 and Q4. The first

stage performs not only the first stage gain function but also performs the level shifting and transconductance reduction functions. By reducing the transconductance, a smaller compensation capacitor (only 5.0 pF) can be employed, thus saving chip area. The transconductance reduction is accomplished by splitting the collectors of Q24 and Q22. Another feature of this input stage is that the input common mode range can include the negative supply or ground, in single supply operation, without saturating either the input devices or the differential to single-ended converter. The second stage consists of a standard current source load amplifier stage.

The output stage is unique because it allows the output to swing to ground in single supply operation and yet does not exhibit any crossover distortion in split supply operation. This is possible because Class AB operation is utilized.

Each amplifier is biased from an internal voltage regulator which has a low temperature coefficient, thus giving each amplifier good temperature characteristics as well as excellent power supply rejection.

Figure 1. Sine Wave Response

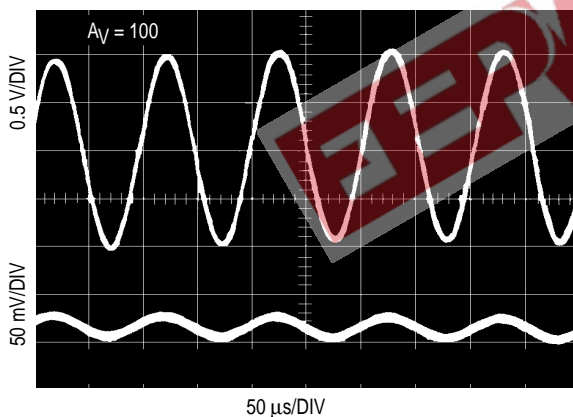
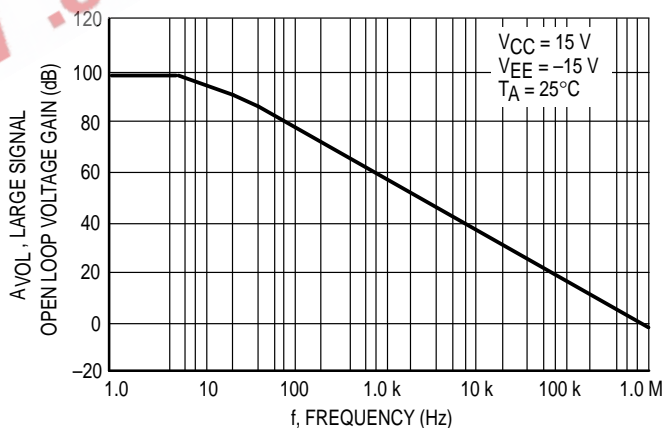

Figure 2. Open Loop Frequency Response



MC3403 MC3303

Figure 3. Power Bandwidth

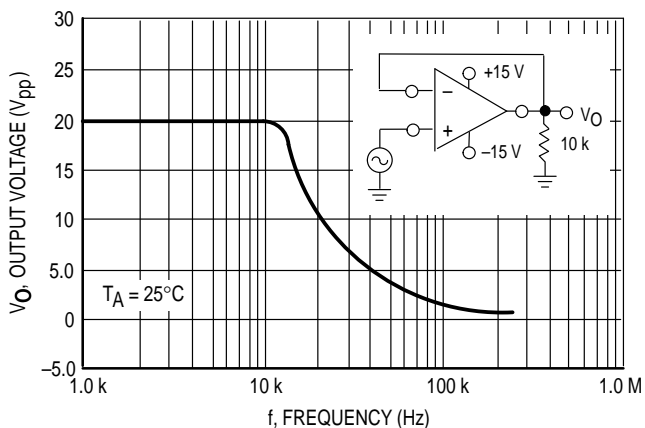

Figure 4. Output Swing versus Supply Voltage

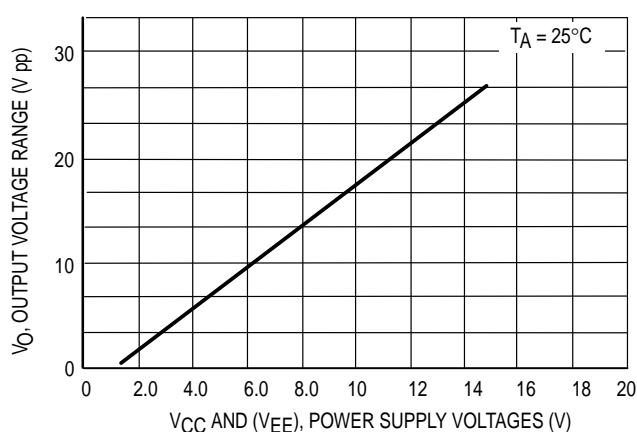

Figure 5. Input Bias Current versus Temperature

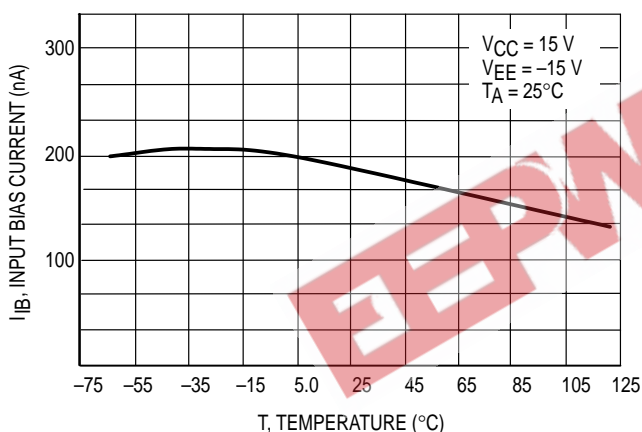

Figure 6. Input Bias Current versus Supply Voltage

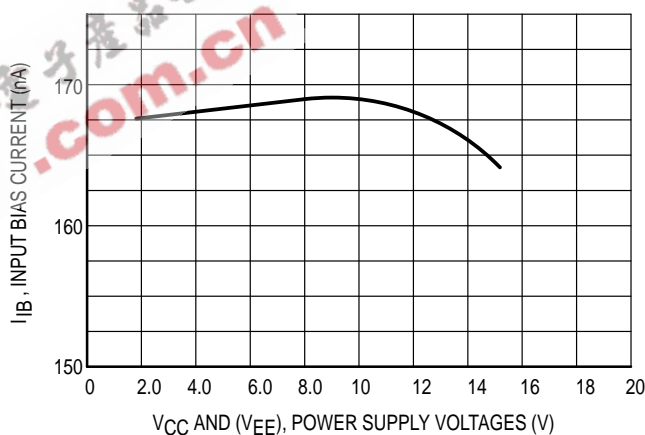

Figure 7. Voltage Reference

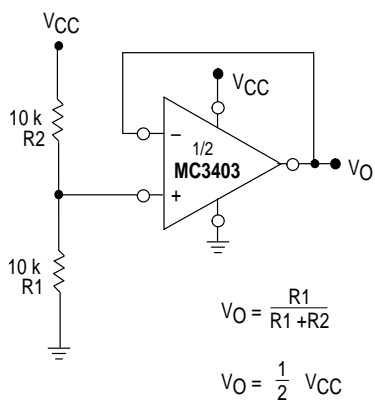
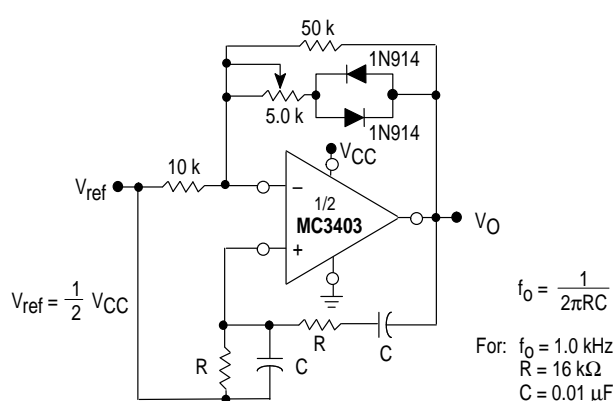

Figure 8. Wien Bridge Oscillator



MC3403 MC3303

Figure 9. High Impedance Differential Amplifier

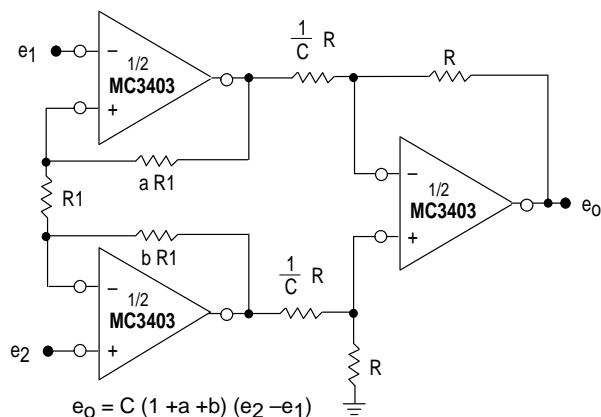

Figure 10. Comparator with Hysteresis

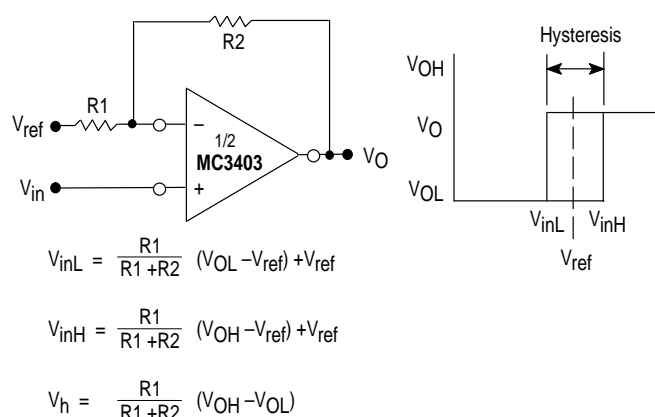

Figure 11. Bi-Quad Filter

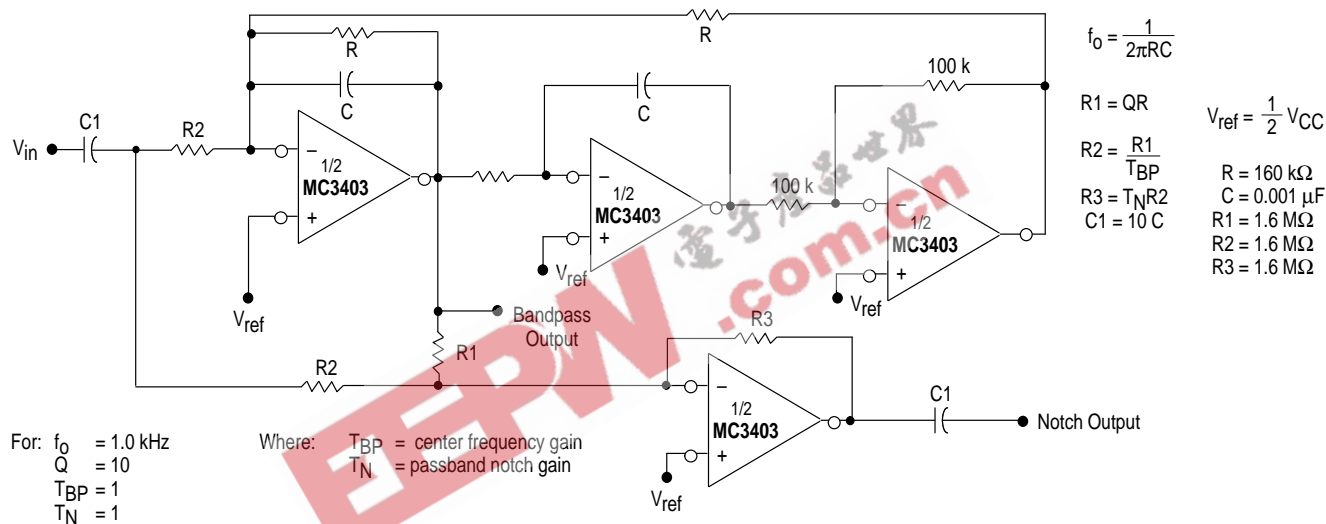

Figure 12. Function Generator

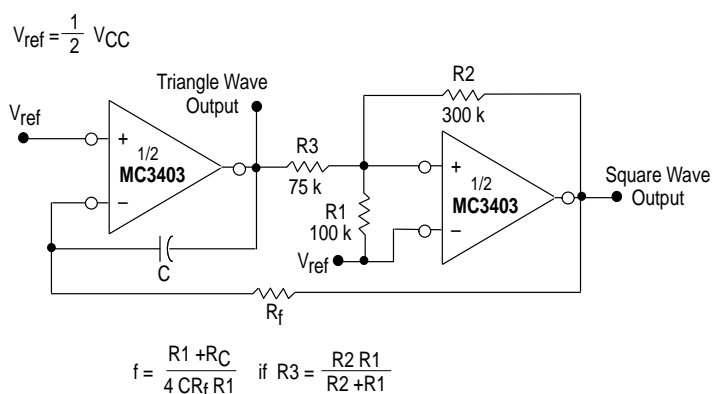
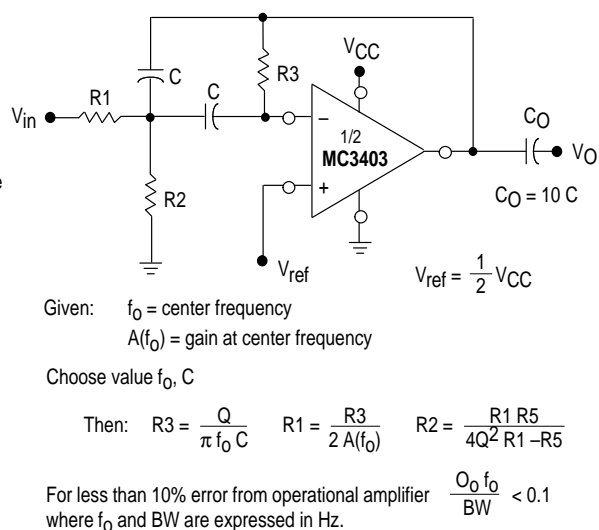

Figure 13. Multiple Feedback Bandpass Filter



If source impedance varies, filter may be preceded with voltage follower buffer to stabilize filter parameters.

MC3403 MC3303

OUTLINE DIMENSIONS

D SUFFIX PLASTIC PACKAGE CASE 751A-03 ISSUE F (SO-14)

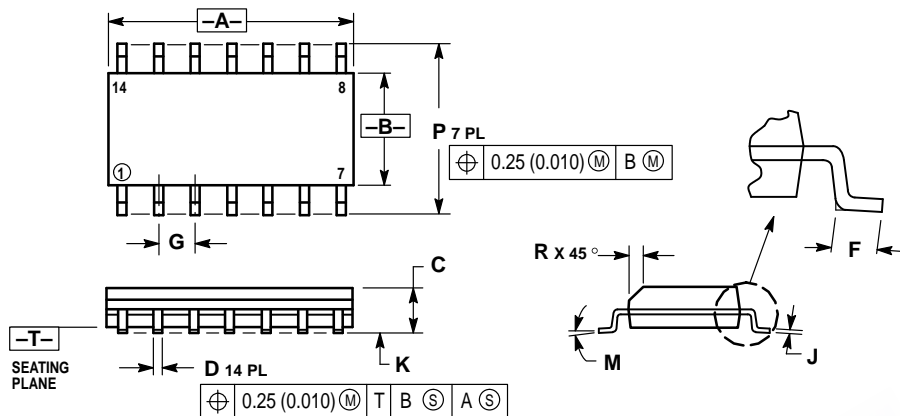

NOTES:

1. DIMENSIONING AND TOLERANCING PER ANSI Y14.5M, 1982.
2. CONTROLLING DIMENSION: MILLIMETER.
3. DIMENSIONS A AND B DO NOT INCLUDE MOLD PROTRUSION.
4. MAXIMUM MOLD PROTRUSION 0.15 (0.006) PER SIDE.
5. DIMENSION D DOES NOT INCLUDE DAMBAR PROTRUSION. ALLOWABLE DAMBAR PROTRUSION SHALL BE 0.127 (0.005) TOTAL IN EXCESS OF THE D DIMENSION AT MAXIMUM MATERIAL CONDITION.

DIM	MILLIMETERS		INCHES	
	MIN	MAX	MIN	MAX
A	8.55	8.75	0.337	0.344
B	3.80	4.00	0.150	0.157
C	1.35	1.75	0.054	0.068
D	0.35	0.49	0.014	0.019
F	0.40	1.25	0.016	0.049
G	1.27 BSC		0.050 BSC	
J	0.19	0.25	0.008	0.009
K	0.10	0.25	0.004	0.009
M	0°	7°	0°	7°
P	5.80	6.20	0.228	0.244
R	0.25	0.50	0.010	0.019

P SUFFIX PLASTIC PACKAGE CASE 646-06 ISSUE L

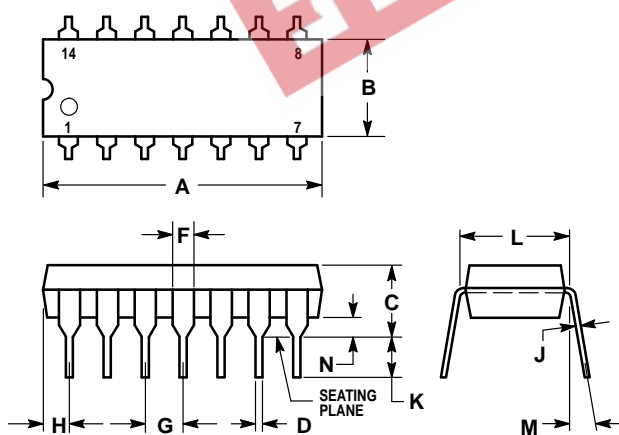

NOTES:

1. LEADS WITHIN 0.13 (0.005) RADIUS OF TRUE POSITION AT SEATING PLANE AT MAXIMUM MATERIAL CONDITION.
2. DIMENSION L TO CENTER OF LEADS WHEN FORMED PARALLEL.
3. DIMENSION B DOES NOT INCLUDE MOLD FLASH.
4. ROUNDED CORNERS OPTIONAL.

DIM	INCHES		MILLIMETERS	
	MIN	MAX	MIN	MAX
A	0.715	0.770	18.16	19.56
B	0.240	0.260	6.10	6.60
C	0.145	0.185	3.69	4.69
D	0.015	0.021	0.38	0.53
F	0.040	0.070	1.02	1.78
G	0.100 BSC		2.54 BSC	
H	0.052	0.095	1.32	2.41
J	0.008	0.015	0.20	0.38
K	0.115	0.135	2.92	3.43
L	0.300 BSC		7.62 BSC	
M	0°	10°	0°	10°
N	0.015	0.039	0.39	1.01

MC3403 MC3303

EEPW 电子产品世界
.com.cn

Motorola reserves the right to make changes without further notice to any products herein. Motorola makes no warranty, representation or guarantee regarding the suitability of its products for any particular purpose, nor does Motorola assume any liability arising out of the application or use of any product or circuit, and specifically disclaims any and all liability, including without limitation consequential or incidental damages. "Typical" parameters which may be provided in Motorola data sheets and/or specifications can and do vary in different applications and actual performance may vary over time. All operating parameters, including "Typicals" must be validated for each customer application by customer's technical experts. Motorola does not convey any license under its patent rights nor the rights of others. Motorola products are not designed, intended, or authorized for use as components in systems intended for surgical implant into the body, or other applications intended to support or sustain life, or for any other application in which the failure of the Motorola product could create a situation where personal injury or death may occur. Should Buyer purchase or use Motorola products for any such unintended or unauthorized application, Buyer shall indemnify and hold Motorola and its officers, employees, subsidiaries, affiliates, and distributors harmless against all claims, costs, damages, and expenses, and reasonable attorney fees arising out of, directly or indirectly, any claim of personal injury or death associated with such unintended or unauthorized use, even if such claim alleges that Motorola was negligent regarding the design or manufacture of the part. Motorola and  are registered trademarks of Motorola, Inc. Motorola, Inc. is an Equal Opportunity/Affirmative Action Employer.

How to reach us:

USA/EUROPE/Locations Not Listed: Motorola Literature Distribution;
P.O. Box 20912; Phoenix, Arizona 85036. 1-800-441-2447 or 602-303-5454

MFAX: RMFAX0@email.sps.mot.com – TOUCHTONE 602-244-6609
INTERNET: <http://Design-NET.com>

JAPAN: Nippon Motorola Ltd.; Tatsumi-SPD-JLDC, 6F Seibu-Butsuryu-Center,
3-14-2 Tatsumi Koto-Ku, Tokyo 135, Japan. 03-81-3521-8315

ASIA/PACIFIC: Motorola Semiconductors H.K. Ltd.; 8B Tai Ping Industrial Park,
51 Ting Kok Road, Tai Po, N.T., Hong Kong. 852-26629298



MOTOROLA



MC3403/D

