

- OUTPUT SWITCH CURRENT IN EXCESS OF 1.5A
- 2% REFERENCE ACCURACY
- LOW QUIESCENT CURRENT:2.5mA(TYP.)
- OPERATING FROM 3V TO 40V
- FREQUENCY OPERATION TO 100KHz
- ACTIVE CURRENT LIMITING

DESCRIPTION

The MC34063A series is a monolithic control circuit delivering the main functions for DC-DC voltage converting.

The device contains an internal temperature compensated reference, comparator, duty cycle controlled oscillator with an active current limit circuit driver and high current output switch.

Output voltage is adjustable through two external resistors with a 2% reference accuracy.

Employing a minimum number of external components the MC34063A devices series is designed for Step-Down, Step-Up and Voltage-Inverting applications.

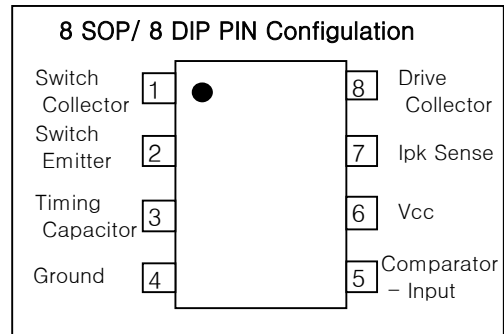

ORDERING INFORMATION

Device	Package
MC34063AD	8 SOP
MC34063AN	8 DIP

BLOCK DIAGRAM

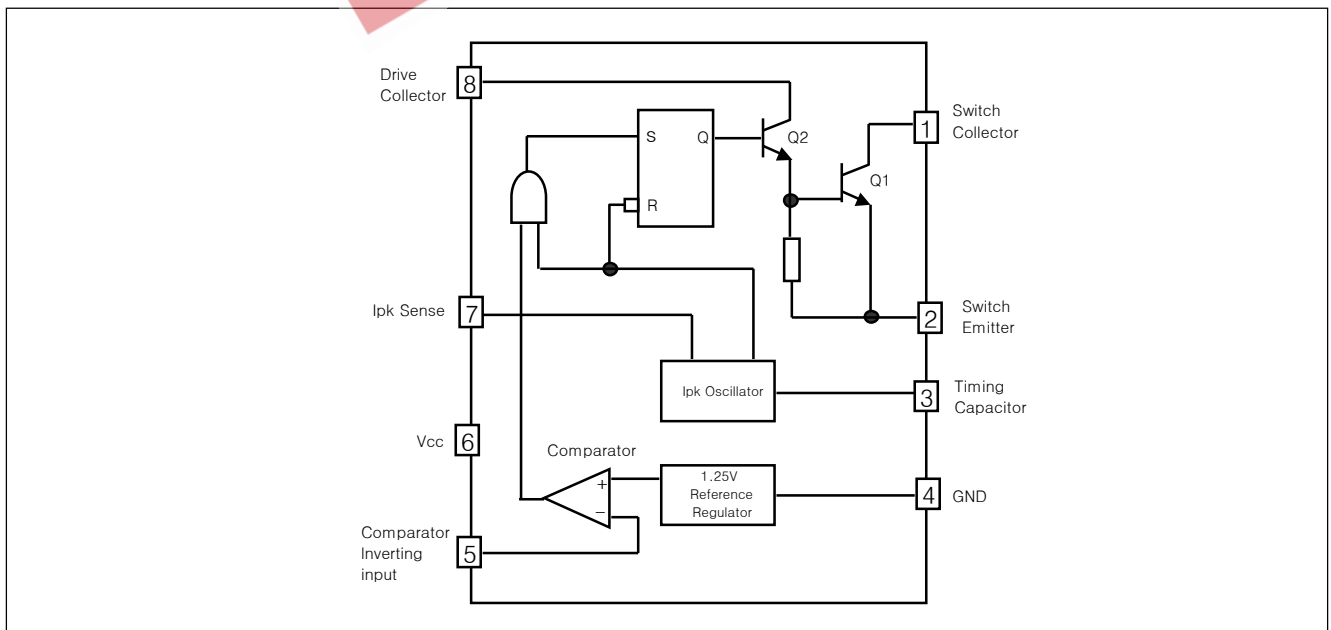

ABSOLUTE MAXIMUM RATINGS

SYMBOL	PARAMETER	VALUE	UNIT
V_{CC}	Power Supply Voltage	50	V
V_{ir}	Comparator input Voltage Range	-0.3 to 40	V
V_{SWC}	Switch Collector Voltage	40	V
V_{SWE}	Switch Emitter Voltage (VSWC=40V)	40	V
V_{CE}	Switch Collector to Emitter Voltage	40	V
V_{dc}	Driver Collector Voltage	40	V
I_{dc}	Driver Collector Current	100	mA
I_{sw}	Switch Current	1.5	A
P_{tot}	Power Dissipation at $T_{amb}=25^{\circ}\text{C}$ (for Plastic Package) (for SOIC Package)	1.25 0.625	W
T_{op}	Operating Ambient Temperature Range	0 to 70	$^{\circ}\text{C}$ $^{\circ}\text{C}$ $^{\circ}\text{C}$
T_{stg}	Storage Temperature Range	-40 to 150	$^{\circ}\text{C}$

Absolute Maximum Rating are those values beyond which damage to the device may occur. Functional operation under these condition is not implied.

THERMAL DATA

SYMBOL	PARAMETER	DIP-8	SO-8	UNIT
$R_{thi-amb}$	Thermal Resistance Junction-ambient (*)	100	160	$^{\circ}\text{C}/\text{w}$

(*) This Value depends from thermal design of PCB on which the device is mounted.

CONNECTION DIAGRAM (top view)

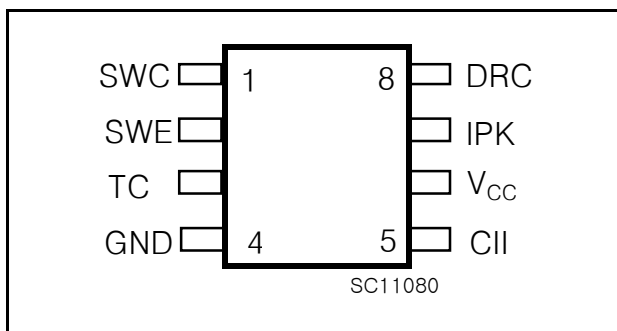

PIN CONNECTIONS

PIN NO	SYMBOL	NAME AND FUNCTION
1	SWC	Switch Collector
2	SWE	Switch Emitter
3	TC	Timing Capactor
4	GND	Ground
5	CII	Comparator Inverting Input
6	Vcc	Voltage Supply
7	I_{PK}	I_{PK} Sense
8	DRC	Voltage Driver Collector

ELECTRICAL CHARACTERISTICS (Refer to the test circuits, $V_{CC}=5V$, $T_a=T_{LOW}$ to T_{HIGH} , unless otherwise specified, see note 2)

OSCILLATOR

SYMBOL	PARAMETER	TEST CONDITIONS	MIN.	TYP.	MAX.	UNIT
F_{OSC}	Frequency	$V_{pin5} = 0V, C_T = 1nF, T_a = 25^\circ C$	24	33	42	KHz
I_{chg}	Charge Current	$V_{CC} = 5$ to $40V, T_a = 25^\circ C$	24	33	42	μA
I_{dischg}	Discharge Current	$V_{CC} = 5$ to $40V, T_a = 25^\circ C$	140	200	260	μA
I_{dischg}/I_{chg}	Discharge to Charge Current Ratio	Pin 7 = $V_{CC}, T_a = 25^\circ C$	5.2	6.2	7.5	
$V_{ipk(sense)}$	Current Limit Sense Voltage	$I_{chg} = I_{dischg}, T_a = 25^\circ C$	250	300	350	mV

OUTPUT SWITCH

SYMBOL	PARAMETER	TEST CONDITIONS	MIN.	TYP.	MAX.	UNIT
$V_{CE(sat)}$	Saturation Voltage, Darlington connection	$I_{SW} = 1A, Pins 1,8$ connected		1	1.3	V
$V_{CE(sat)}$	Saturation Voltage	$I_{SW} = 1A, R_{pin8} = 82\Omega$ to V_{CC} , Forced $\beta \sim 20$		0.45	0.7	V
h_{FE}	DC Current Gain	$I_{SW} = 1A, V_{CE} = 5V, T_a = 25^\circ C$	50	120		
$I_{C(off)}$	Collector Off-State Current	$V_{CE} = 40V$		0.01	100	μA

COMPARATOR

SYMBOL	PARAMETER	TEST CONDITIONS	MIN.	TYP.	MAX.	UNIT
V_{th}	Threshold Voltage	$T_a = 25^\circ C$	1.225	1.25	1.275	V
		$T_a = T_{LOW}$ to T_{HIGH}	1.21		1.29	V
Reg_{line}	Threshold Voltage Line Regulation	$V_{CC} = 3$ to $40V$		1	5	mV
I_{IB}	Input Bias Current	$V_{IN} = 0V$		-5	-400	nA

TOTAL DEVICE

SYMBOL	PARAMETER	TEST CONDITIONS	MIN.	TYP.	MAX.	UNIT
I_{CC}	Supply Current	$V_{CC} = 5$ to $40V, C_T = 1nF$ Pin7 = $V_{CC}, V_{pin5} > V_{th}$, Pin2 = GND Remaining pins open for MC34063A		2.5	4	mA
$V_{START-UP}$	Start-up Voltage(note 4)	$T_a = 25^\circ C, C_T = 1\mu F, Pin5 = 0V$ for MC34063A		2.1		V

Notes:

- Maximum package power dissipation limit must be observed.
- $T_{LOW} = 0^\circ C, T_{HIGH} = 70^\circ C$
- If Darlington configuration is not used, care must be taken to avoid deep saturation of output switch.
The resulting switch-off time may be adversely affected.
In a Darlington configuration the following output driver condition is suggested:
Forced β of output current switch = $I_{COUTPUT}/(I_{CDRIVER} - 1mA^*) \geq 10$
* Current less due to a built in $1K\Omega$ antileakage resistor.
- Start-up Voltage is the minimum Power Supply Voltage at which the internal oscillator begins to work.

TYPICAL ELECTRICAL CHARACTERISTICS

Emitter Follower Configuration Output Saturation Voltage vs Emitter Current

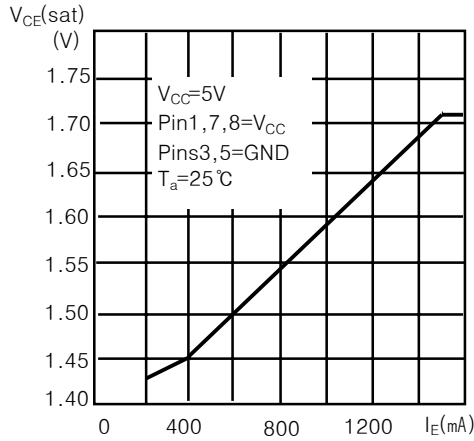

Output Switch ON-OFF Time vs Oscillator Timing Capacitor

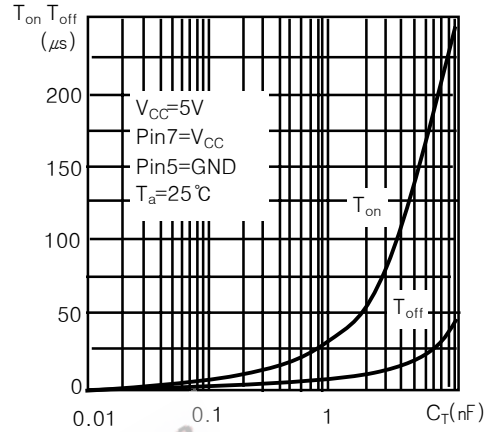

Common Emitter Configuration Output Switch Saturation Voltage vs Collector Current

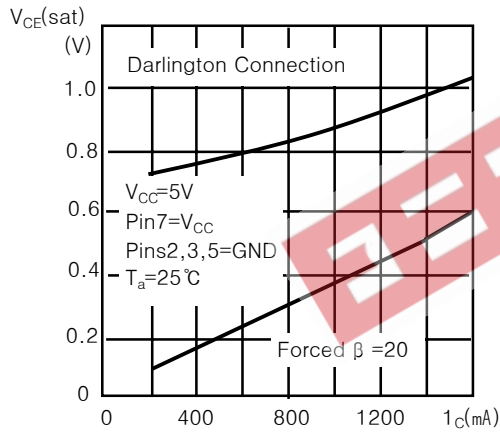

Darlington Configuration Collector Emitter Saturation Voltage (VCE(sat)) vs Temperature

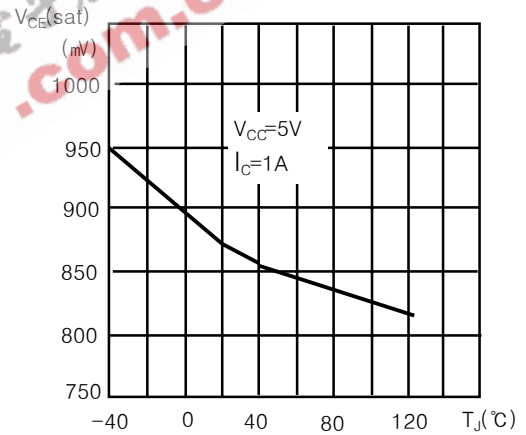

Power Collector Emitter Saturation Voltage (VCE(sat)) vs Temperature

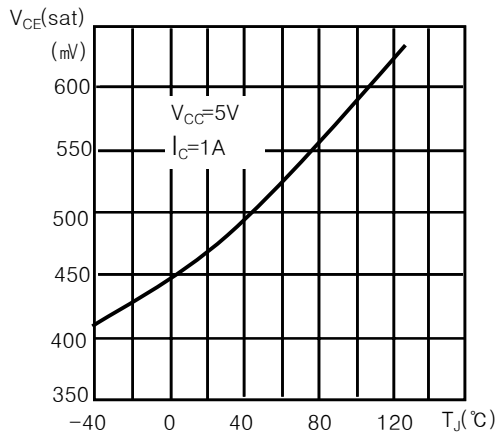

Current Limit Sense Voltage (Vipk) vs Temperature

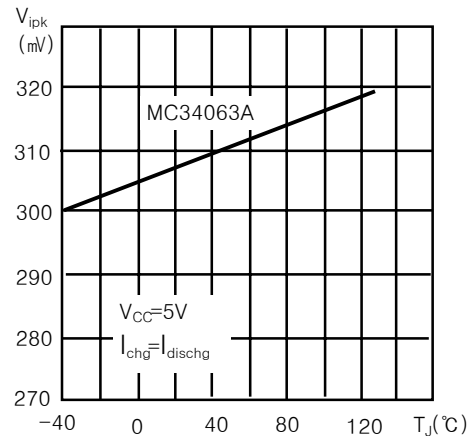

TYPICAL ELECTRICAL CHARACTERISTICS (Continued)

Reference Voltage vs Temperature

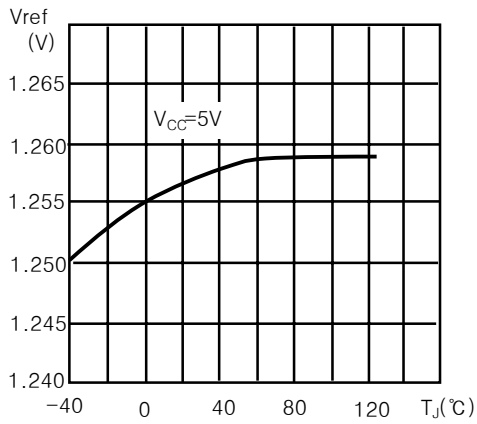

Bias Current vs Temperature

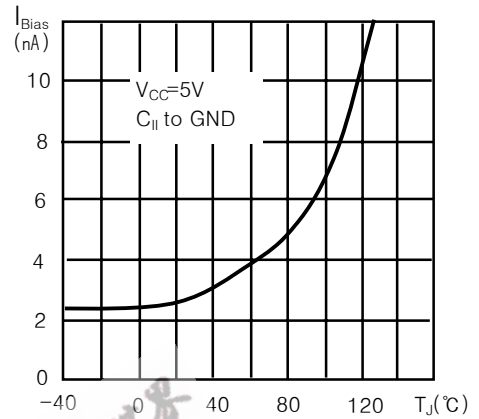

Supply Current vs Temperature

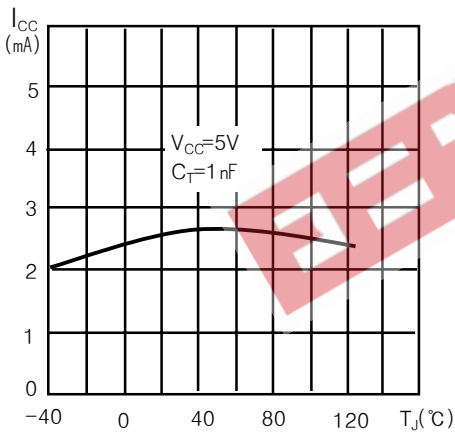

Supply Current vs Input Voltage

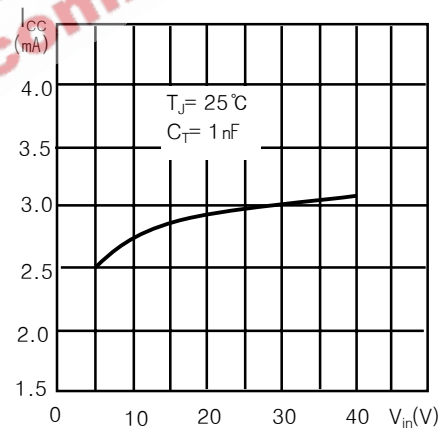

TYPICAL APPLICATION CIRCUIT

Step-Up Converter

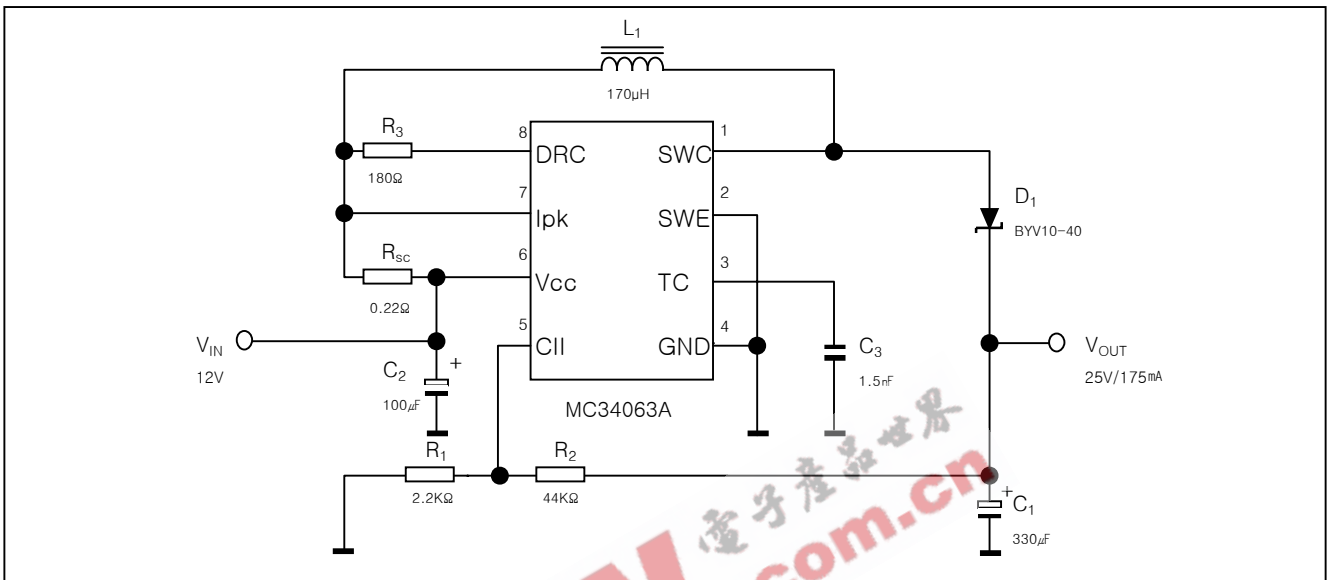

Step-Down Converter

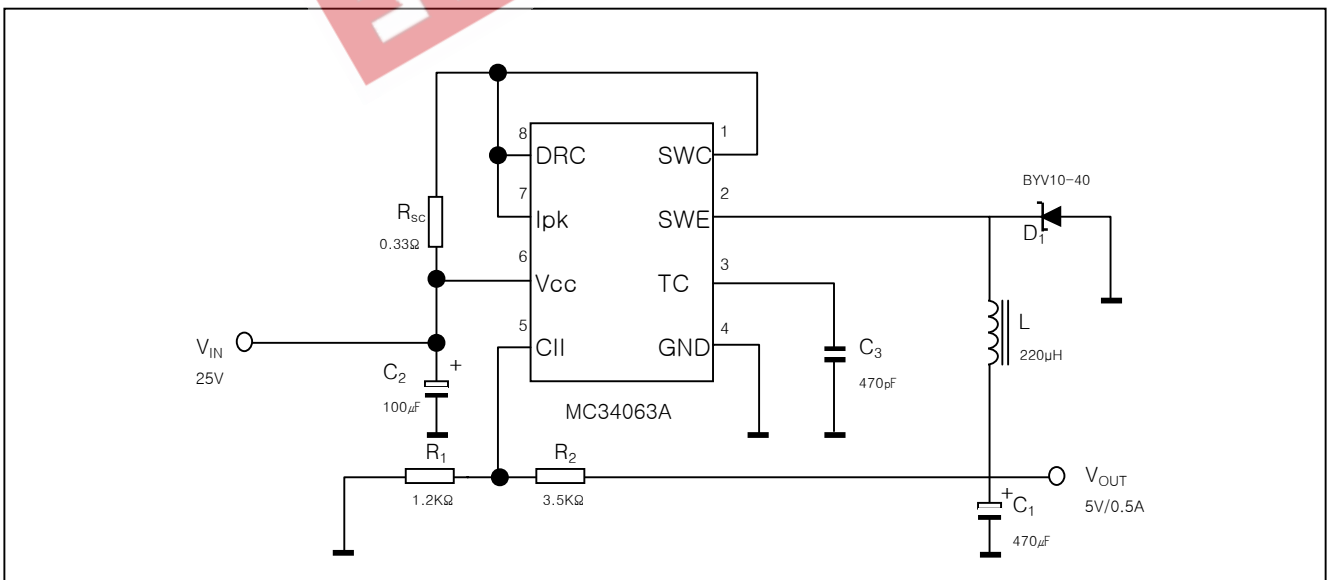

Step-Up With External NPN Switch

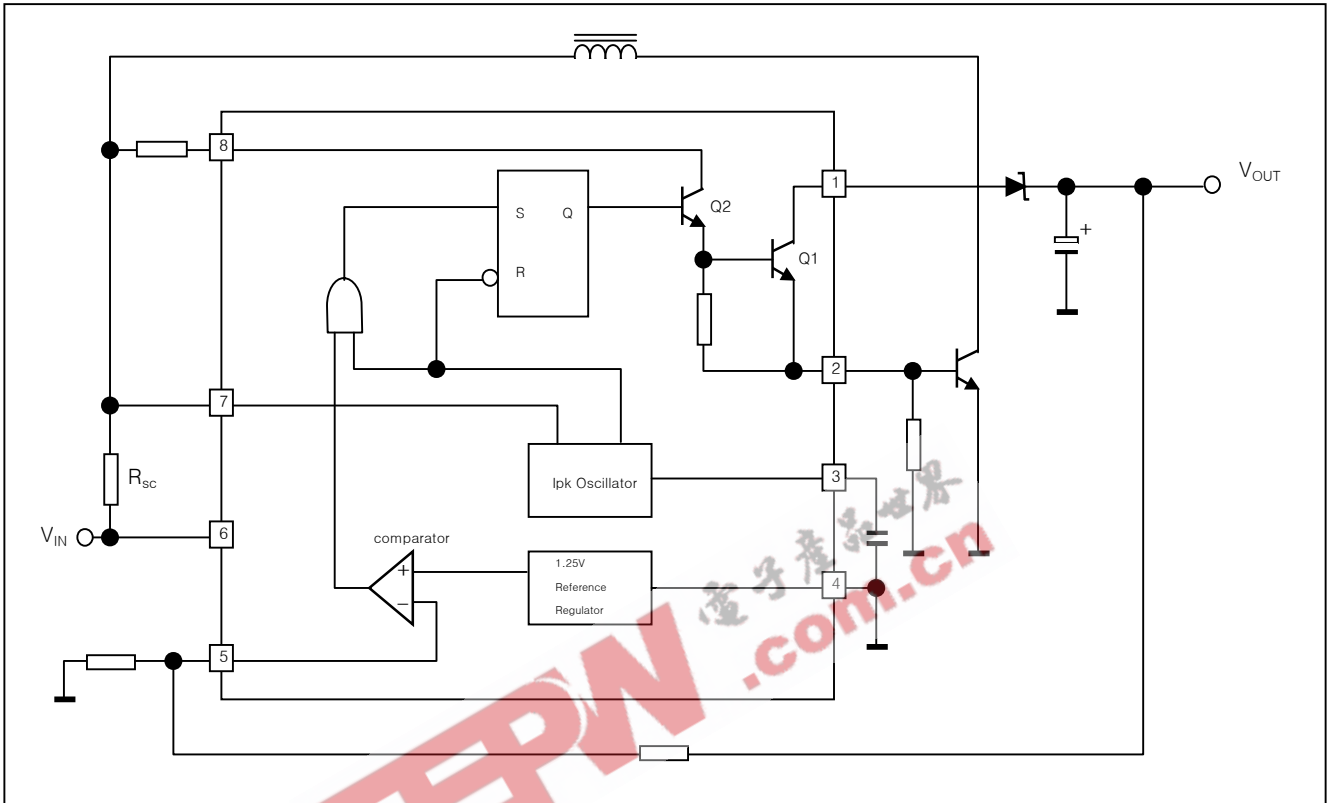

Voltage Inverting Converter

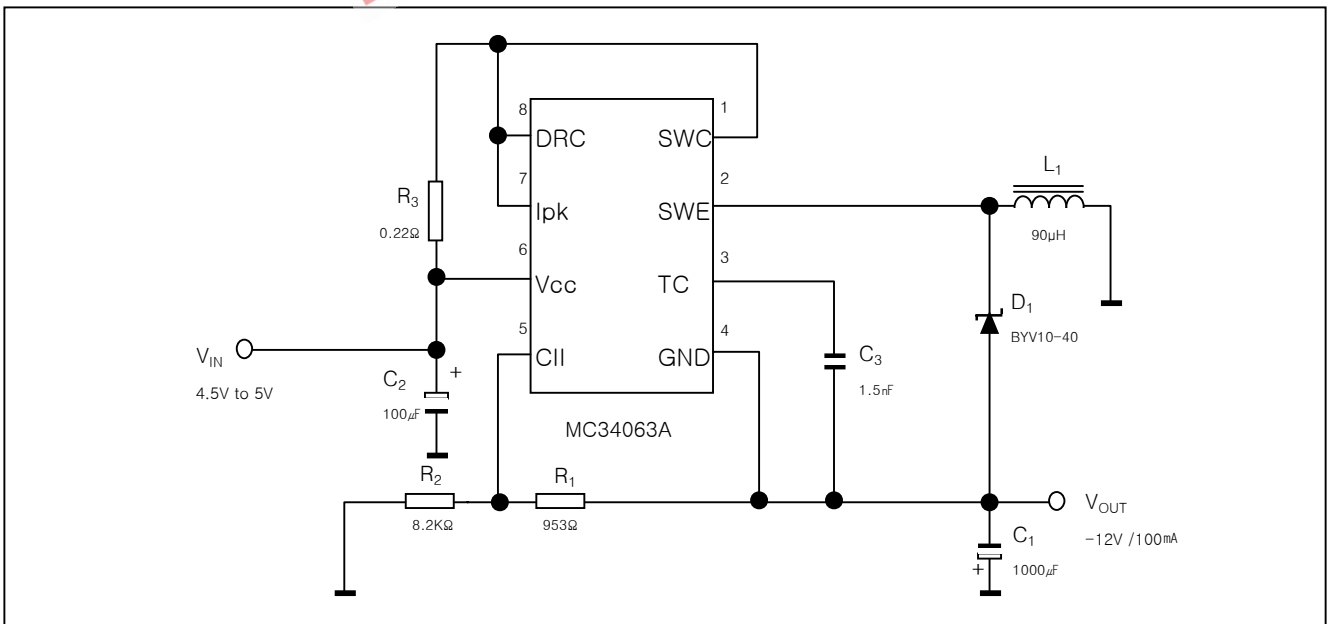

Step-Down With External NPN Switch

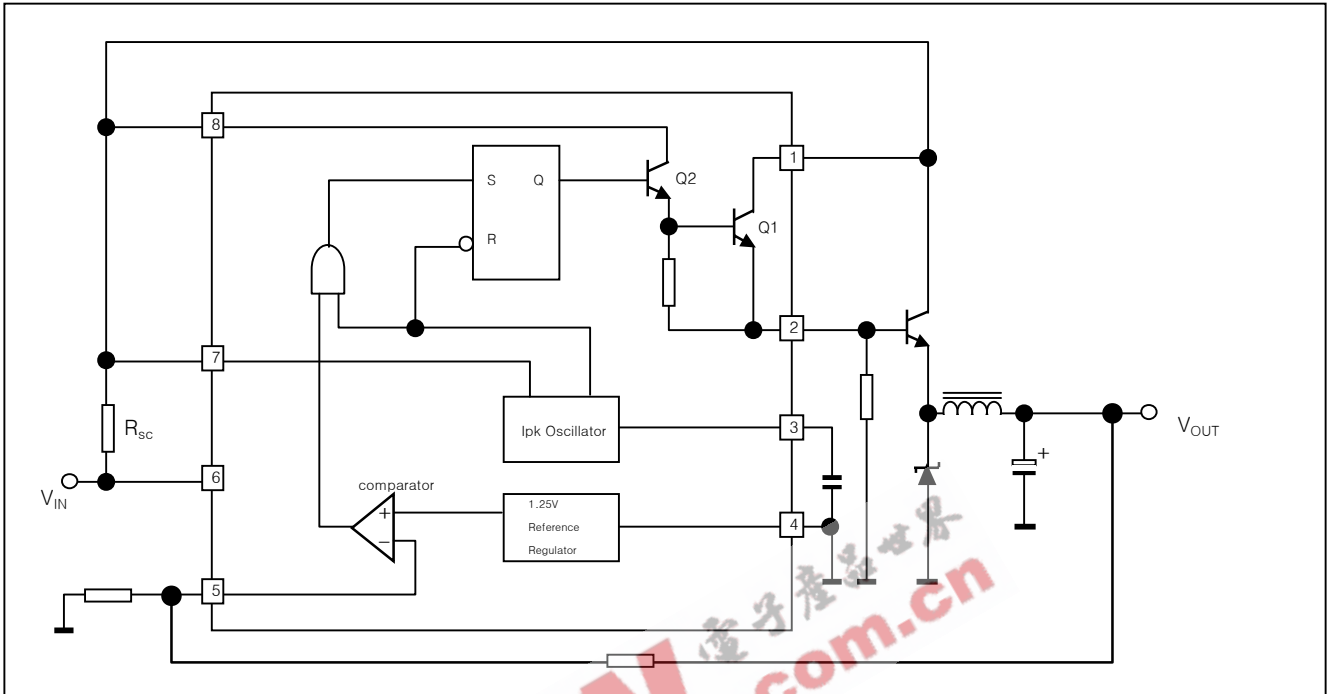

Step-Down With External PNP Switch

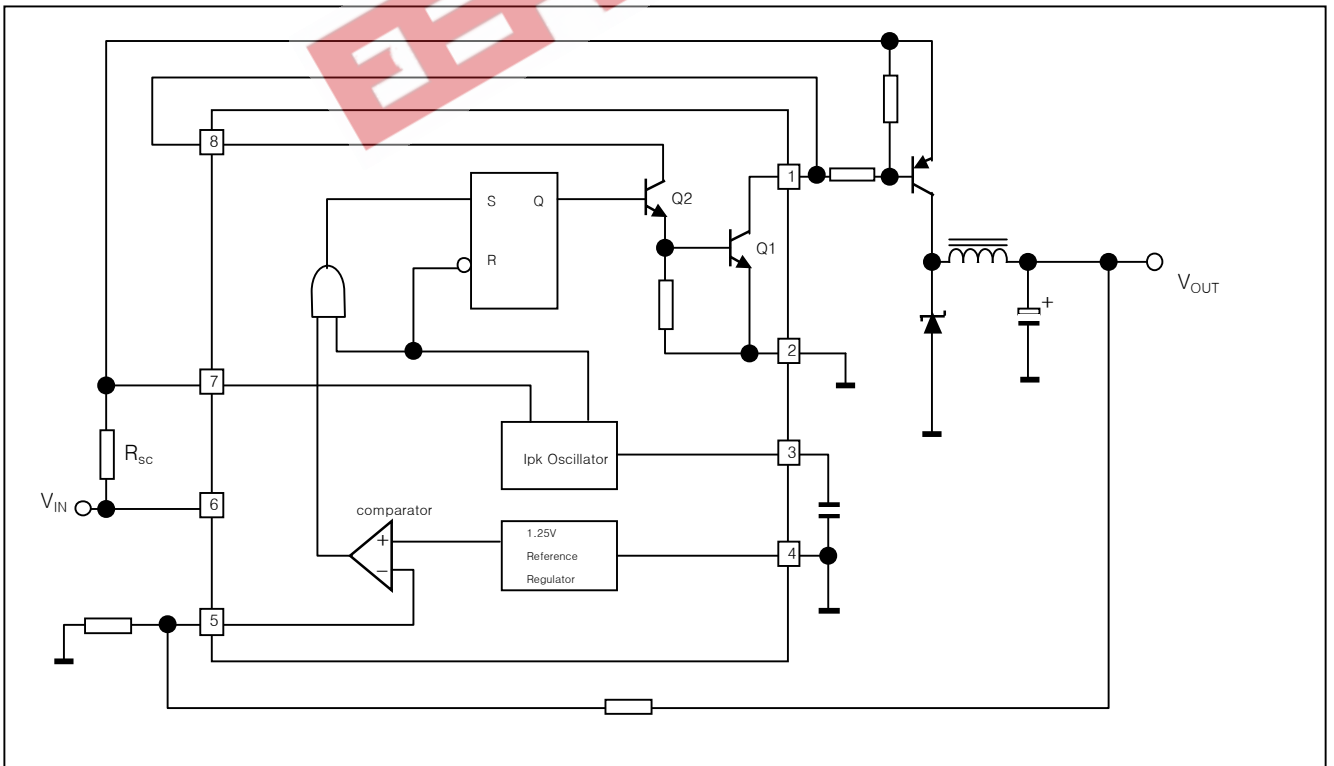

Voltage Inverting With External NPN Switch

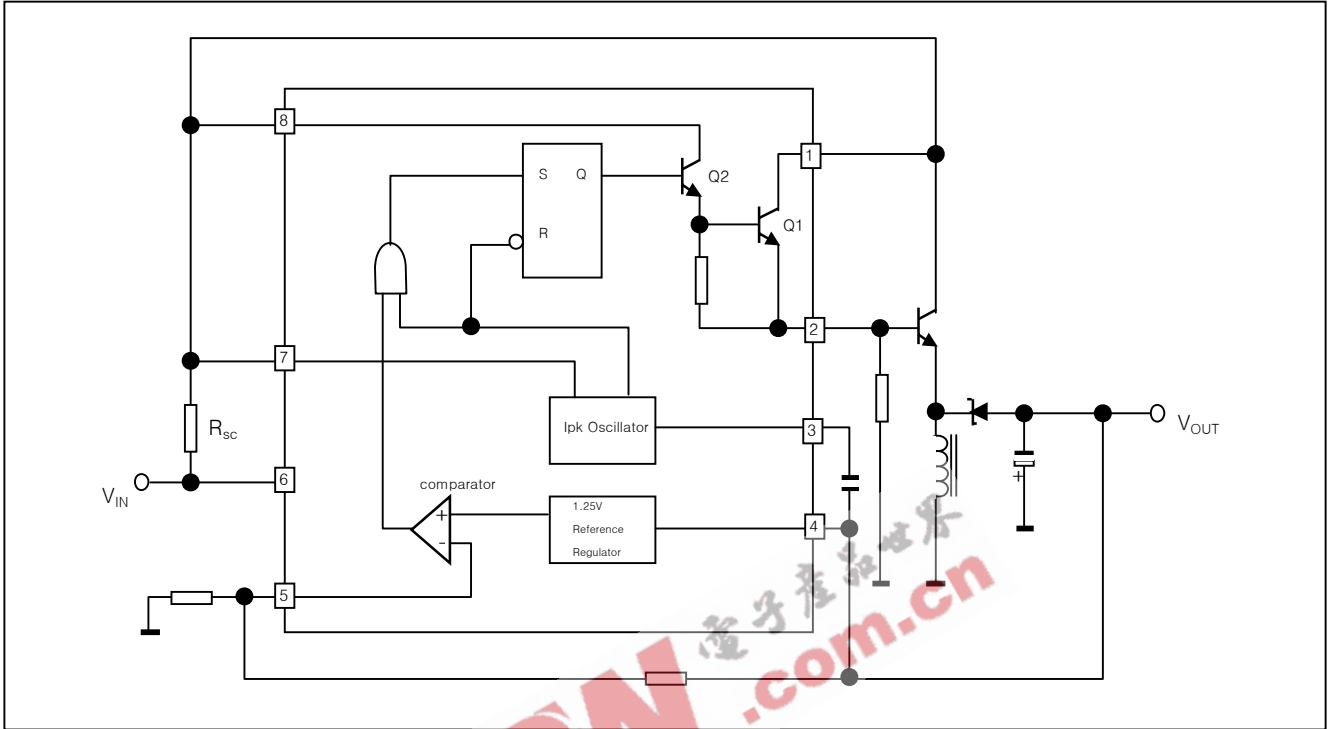

Voltage Inverting With External PNP Saturated Switch

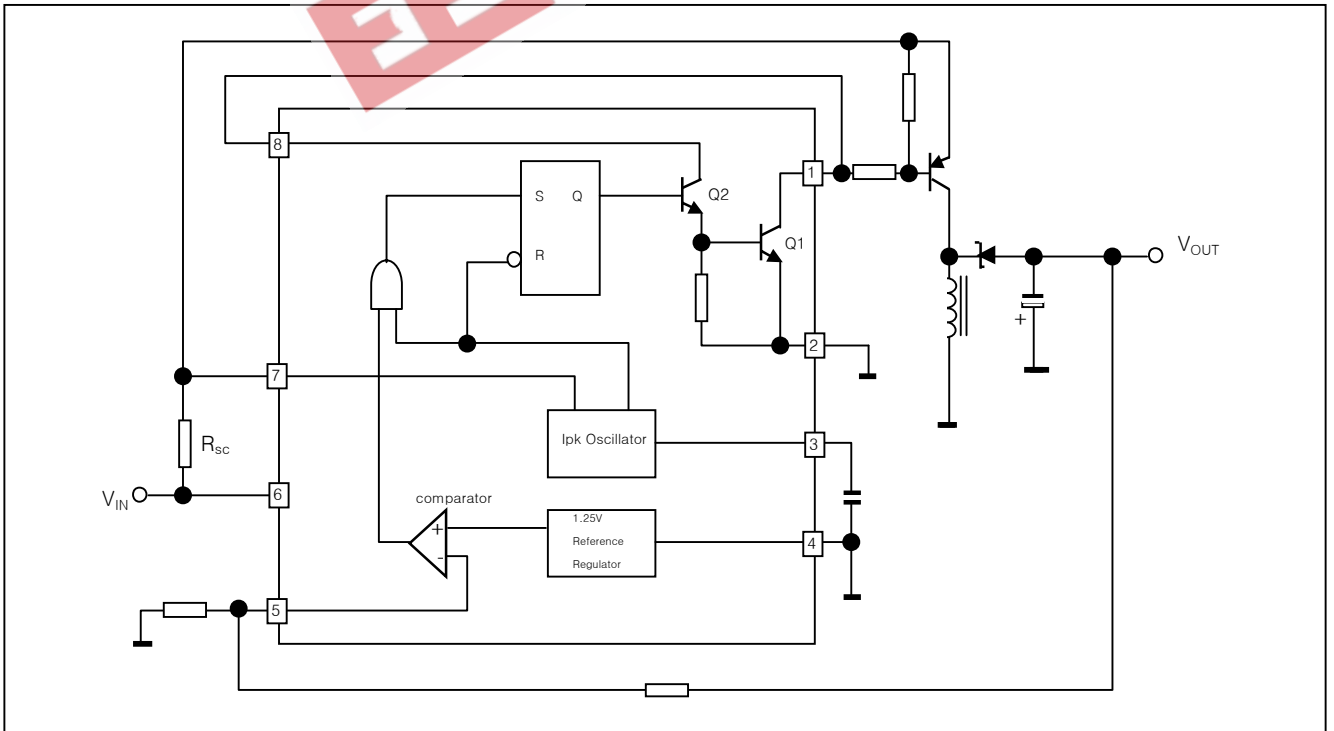

Dual Output Voltage

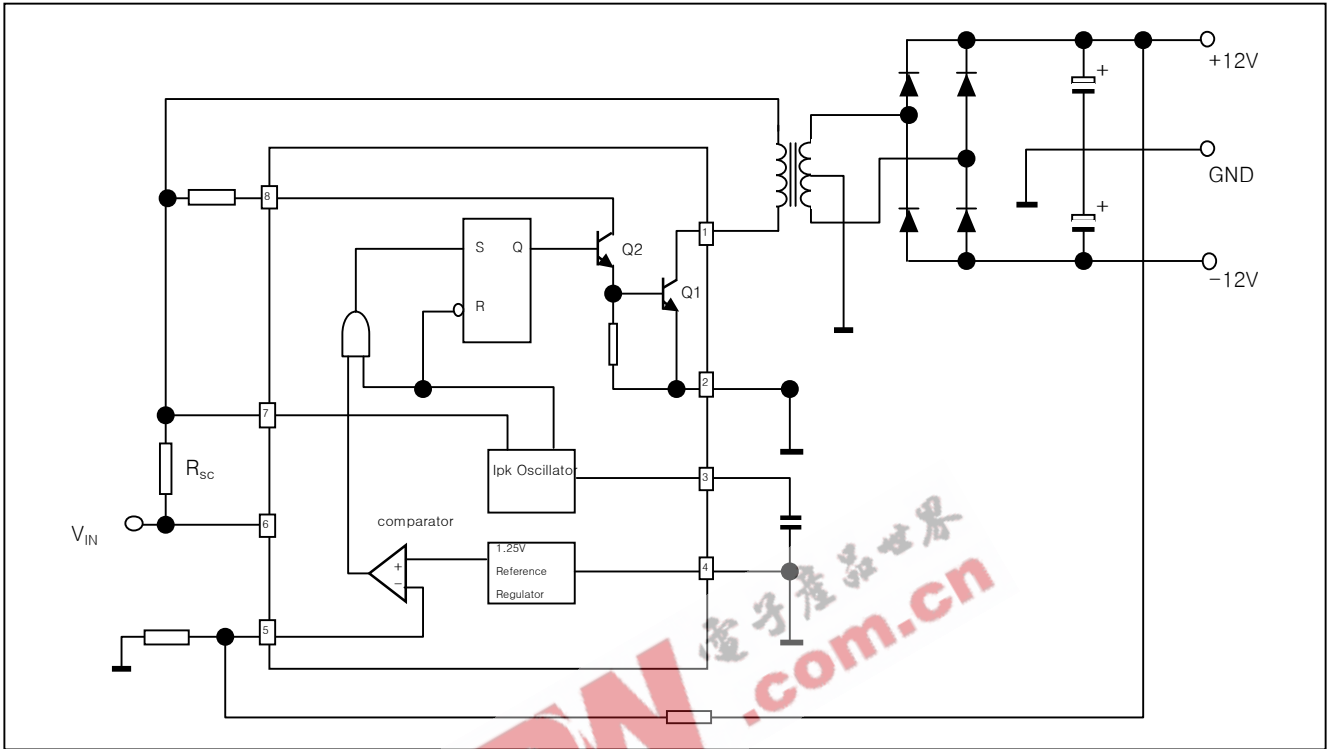

Higher Output Power, Higher Input Voltage

