



# MC34064 MC33064

## Undervoltage Sensing Circuit

The MC34064 is an undervoltage sensing circuit specifically designed for use as a reset controller in microprocessor-based systems. It offers the designer an economical solution for low voltage detection with a single external resistor. The MC34064 features a trimmed-in-package bandgap reference, and a comparator with precise thresholds and built-in hysteresis to prevent erratic reset operation. The open collector reset output is capable of sinking in excess of 10 mA, and operation is guaranteed down to 1.0 V input with low standby current. These devices are packaged in 3-pin TO-226AA, 8-pin SO-8 and Micro-8 surface mount packages.

Applications include direct monitoring of the 5.0 V MPU/logic power supply used in appliance, automotive, consumer and industrial equipment.

- Trimmed-In-Package Temperature Compensated Reference
- Comparator Threshold of 4.6 V at 25°C
- Precise Comparator Thresholds Guaranteed Over Temperature
- Comparator Hysteresis Prevents Erratic Reset
- Reset Output Capable of Sinking in Excess of 10 mA
- Internal Clamp Diode for Discharging Delay Capacitor
- Guaranteed Reset Operation with 1.0 V Input
- Low Standby Current
- Economical TO-226AA, SO-8 and Micro-8 Surface Mount Packages

### UNDERVOLTAGE SENSING CIRCUIT

#### SEMICONDUCTOR TECHNICAL DATA

**P SUFFIX**  
PLASTIC PACKAGE  
CASE 29  
(TO-226AA)



Pin 1. Reset  
2. Input  
3. Ground

**D SUFFIX**  
PLASTIC PACKAGE  
CASE 751  
(SO-8)

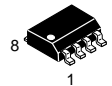

**DM SUFFIX**  
PLASTIC PACKAGE  
CASE 846A  
(Micro-8)

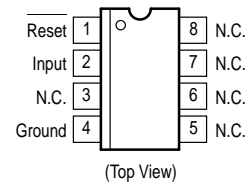

#### Representative Block Diagram

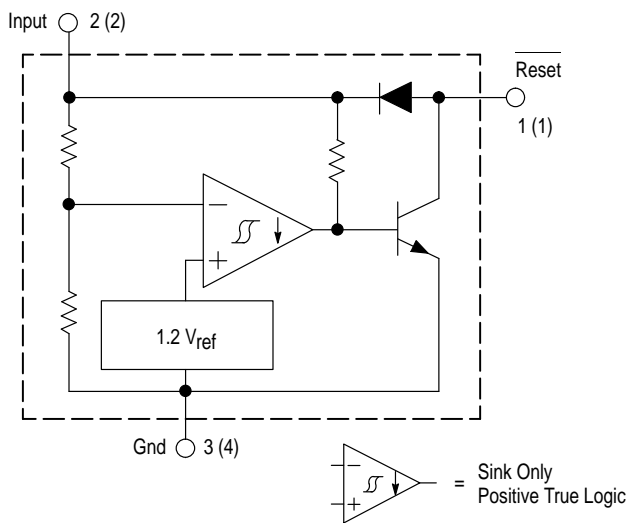

Pin numbers adjacent to terminals are for the 3-pin TO-226AA package.  
Pin numbers in parenthesis are for the 8-lead packages.

This device contains 21 active transistors.

#### ORDERING INFORMATION

Device	Operating Temperature Range	Package
MC34064D-5	T <sub>A</sub> = 0° to +70°C	SO-8
MC34064DM-5		Micro-8
MC34064P-5		TO-226AA
MC33064D-5	T <sub>A</sub> = -40° to +85°C	SO-8
MC33064DM-5		Micro-8
MC33064P-5		TO-226AA

## MC34064 MC33064

### MAXIMUM RATINGS

Rating	Symbol	Value	Unit
Power Input Supply Voltage	$V_{in}$	-1.0 to 10	V
Reset Output Voltage	$V_O$	10	V
Reset Output Sink Current (Note 1)	$I_{Sink}$	Internally Limited	mA
Clamp Diode Forward Current, Pin 1 to 2 (Note 1)	$I_F$	100	mA
Power Dissipation and Thermal Characteristics			
P Suffix, Plastic Package			
Maximum Power Dissipation @ $T_A = 25^\circ\text{C}$	$P_D$	625	mW
Thermal Resistance, Junction-to-Air	$R_{\theta JA}$	200	$^\circ\text{C/W}$
D Suffix, Plastic Package			
Maximum Power Dissipation @ $T_A = 25^\circ\text{C}$	$P_D$	625	mW
Thermal Resistance, Junction-to-Air	$R_{\theta JA}$	200	$^\circ\text{C/W}$
DM Suffix, Plastic Package			
Maximum Power Dissipation @ $T_A = 25^\circ\text{C}$	$P_D$	520	mW
Thermal Resistance, Junction-to-Air	$R_{\theta JA}$	240	$^\circ\text{C/W}$
Operating Junction Temperature	$T_J$	+150	$^\circ\text{C}$
Operating Ambient Temperature	$T_A$		$^\circ\text{C}$
MC34064		0 to +70	
MC33064		-40 to +85	
Storage Temperature Range	$T_{stg}$	-65 to +150	$^\circ\text{C}$

NOTE: ESD data available upon request.

**ELECTRICAL CHARACTERISTICS** (For typical values  $T_A = 25^\circ\text{C}$ , for min/max values  $T_A$  is the operating ambient temperature range that applies [Notes 2 and 3] unless otherwise noted.)

Characteristics	Symbol	Min	Typ	Max	Unit
<b>COMPARATOR</b>					
Threshold Voltage					V
High State Output ( $V_{in}$ Increasing)	$V_{IH}$	4.5	4.61	4.7	
Low State Output ( $V_{in}$ Decreasing)	$V_{IL}$	4.5	4.59	4.7	
Hysteresis	$V_H$	0.01	0.02	0.05	
<b>RESET OUTPUT</b>					
Output Sink Saturation	$V_{OL}$				V
( $V_{in} = 4.0\text{ V}$ , $I_{Sink} = 8.0\text{ mA}$ )		–	0.46	1.0	
( $V_{in} = 4.0\text{ V}$ , $I_{Sink} = 2.0\text{ mA}$ )		–	0.15	0.4	
( $V_{in} = 1.0\text{ V}$ , $I_{Sink} = 0.1\text{ mA}$ )		–	–	0.1	
Output Sink Current ( $V_{in}$ , Reset = 4.0 V)	$I_{Sink}$	10	27	60	mA
Output Off-State Leakage ( $V_{in}$ , Reset = 5.0 V)	$I_{OH}$	–	0.02	0.5	$\mu\text{A}$
Clamp Diode Forward Voltage, Pin 1 to 2 ( $I_F = 10\text{ mA}$ )	$V_F$	0.6	0.9	1.2	V
<b>TOTAL DEVICE</b>					
Operating Input Voltage Range	$V_{in}$	1.0 to 6.5	–	–	V
Quiescent Input Current ( $V_{in} = 5.0\text{ V}$ )	$I_{in}$	–	390	500	$\mu\text{A}$

NOTES: 1. Maximum package power dissipation limits must be observed.  
 2. Low duty cycle pulse techniques are used during test to maintain junction temperature as close to ambient as possible.  
 3.  $T_{low} = 0^\circ\text{C}$  for MC34064       $T_{high} = +70^\circ\text{C}$  for MC34064  
        $-40^\circ\text{C}$  for MC33064         $+85^\circ\text{C}$  for MC33064

# MC34064 MC33064

**Figure 1. Reset Output Voltage versus Input Voltage**

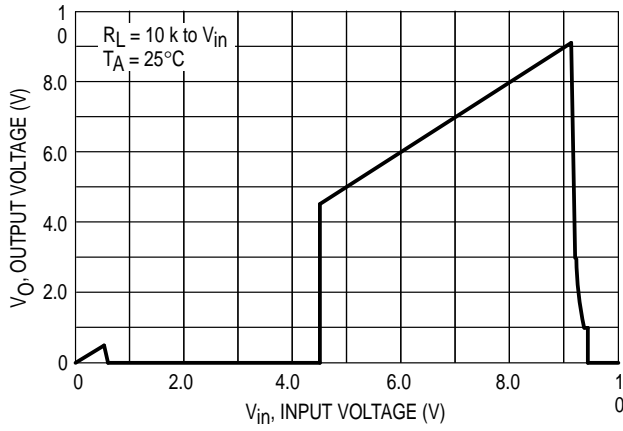

**Figure 2. Reset Output Voltage versus Input Voltage**

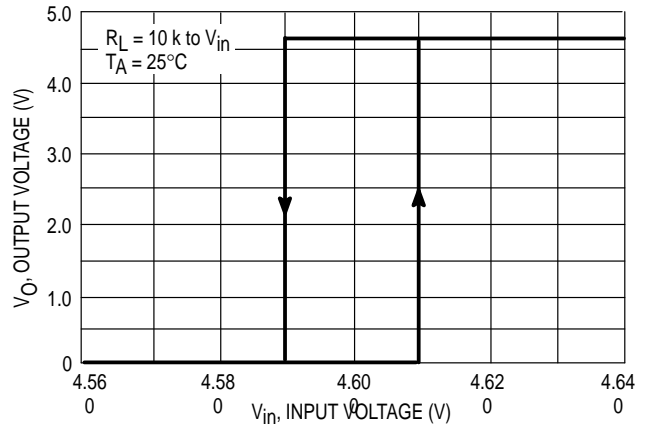

**Figure 3. Comparator Threshold Voltage versus Temperature**

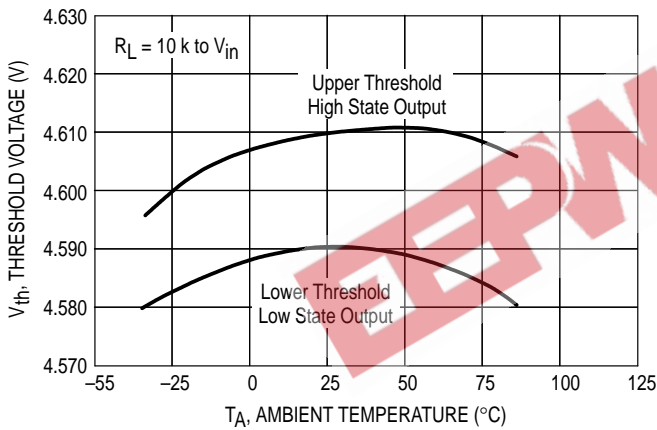

**Figure 4. Input Current versus Input Voltage**

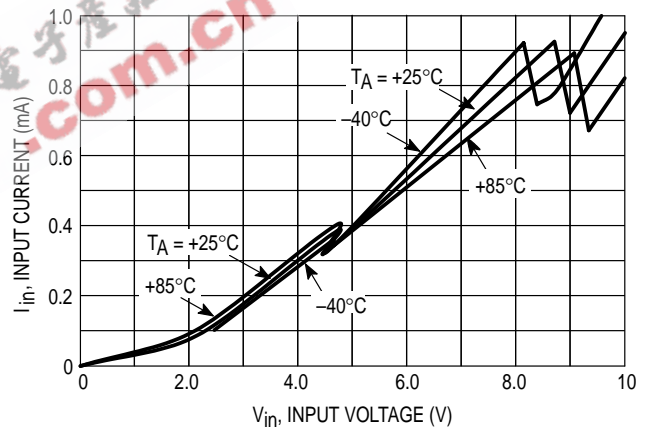

**Figure 5. Reset Output Saturation versus Sink Current**

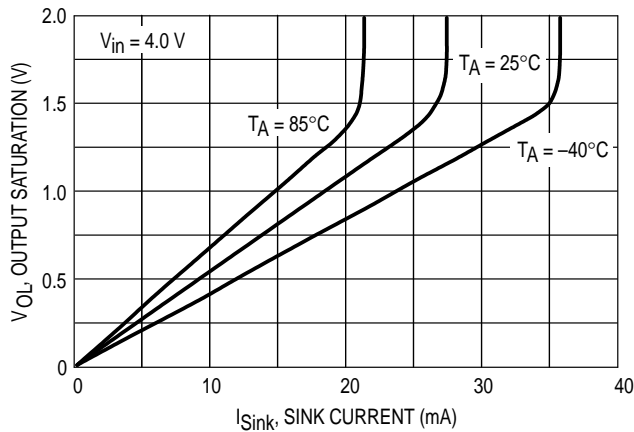

**Figure 6. Reset Delay Time**

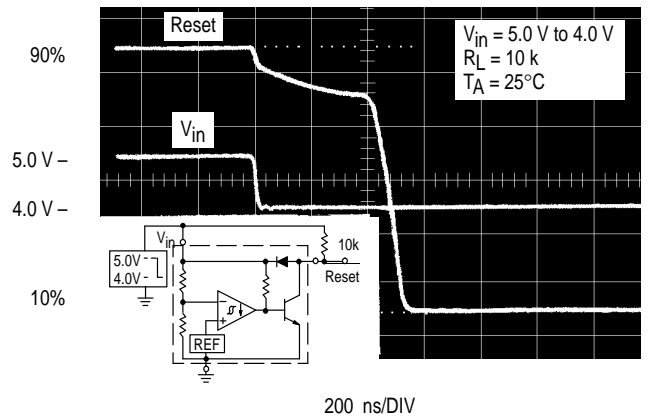

## MC34064 MC33064

Figure 7. Clamp Diode Forward Current versus Voltage

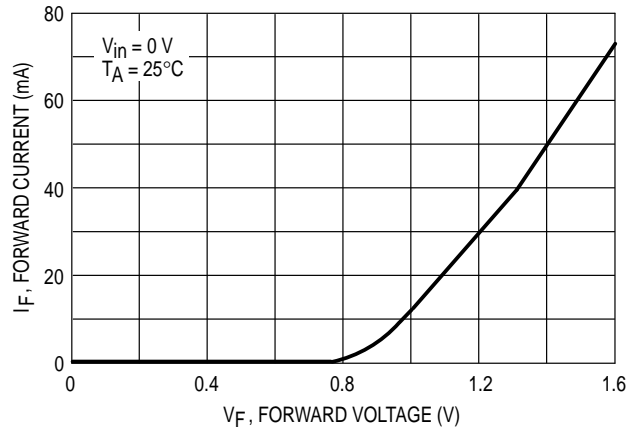

Figure 8. Low Voltage Microprocessor Reset

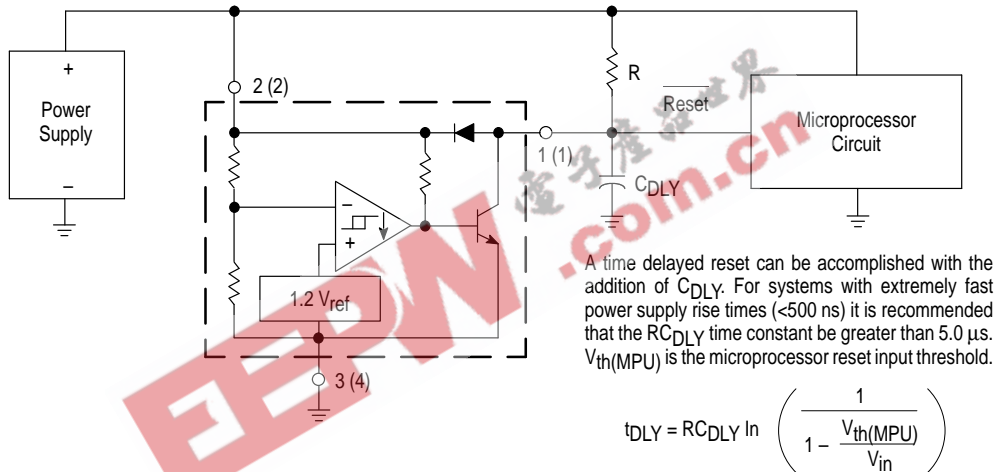
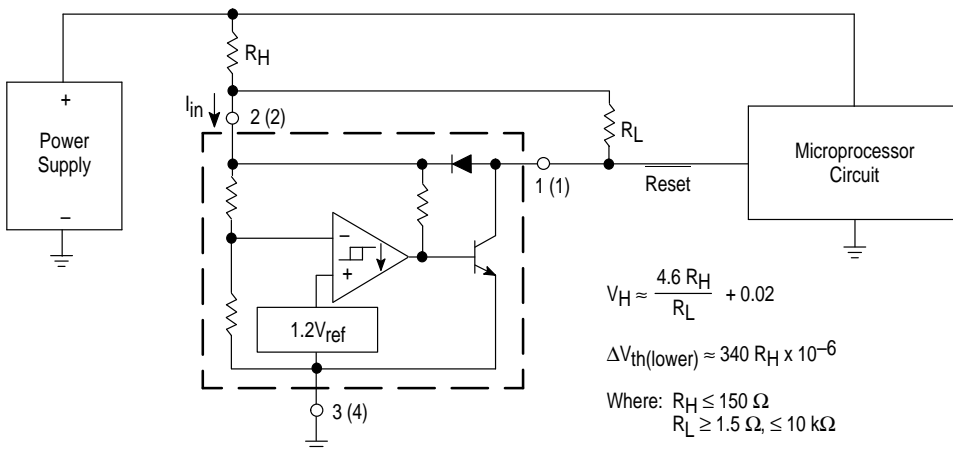

Figure 9. Low Voltage Microprocessor Reset with Additional Hysteresis



Comparator hysteresis can be increased with the addition of resistor  $R_H$ . The hysteresis equation has been simplified and does not account for the change of input current  $I_{in}$  as  $V_{CC}$  crosses the comparator threshold (Figure 4). An increase of the lower threshold  $\Delta V_{th(lower)}$  will be observed due to  $I_{in}$  which is typically  $340 \mu\text{A}$  at  $4.59 \text{ V}$ . The equations are accurate to  $\pm 10\%$  with  $R_H$  less than  $150 \Omega$  and  $R_L$  between  $1.5 \text{ k}\Omega$  and  $10 \text{ k}\Omega$ .

Test Data			
$V_H$ (mV)	$\Delta V_{th}$ (mV)	$R_H$ ( $\Omega$ )	$R_L$ (k $\Omega$ )
20	0	0	0
51	3.4	10	1.5
40	6.8	20	4.7
81	6.8	20	1.5
71	10	30	2.7
112	10	30	1.5
100	16	47	2.7
164	16	47	1.5
190	34	100	2.7
327	34	100	1.5
276	51	150	2.7
480	51	150	1.5

## MC34064 MC33064

Figure 10. Voltage Monitor

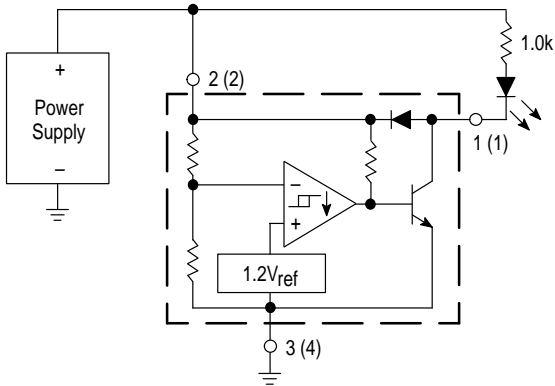

Figure 11. Solar Powered Battery Charger

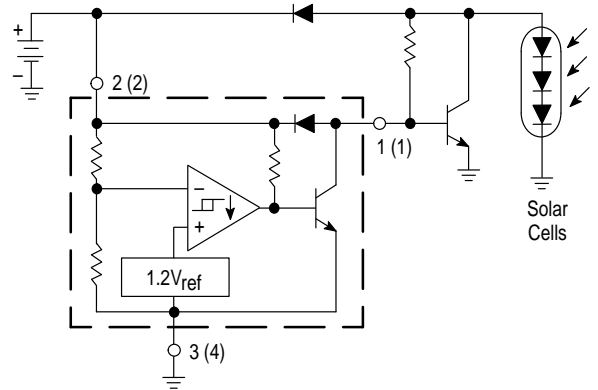
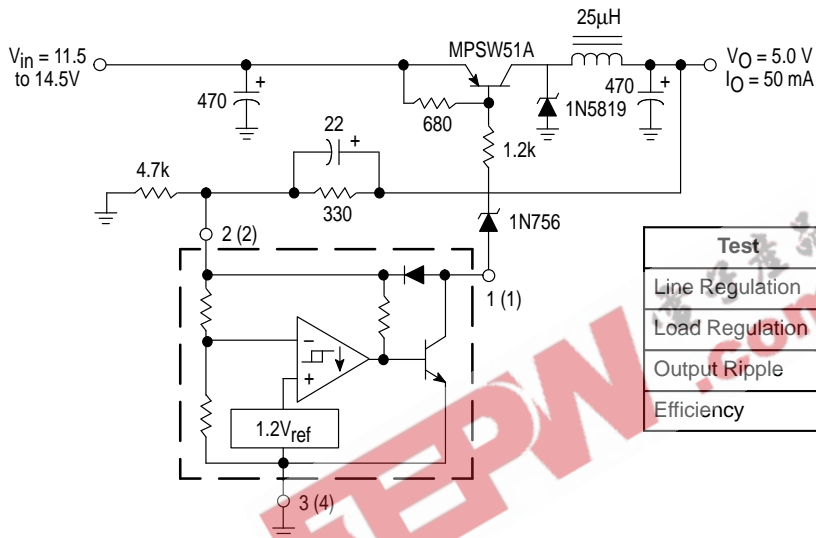
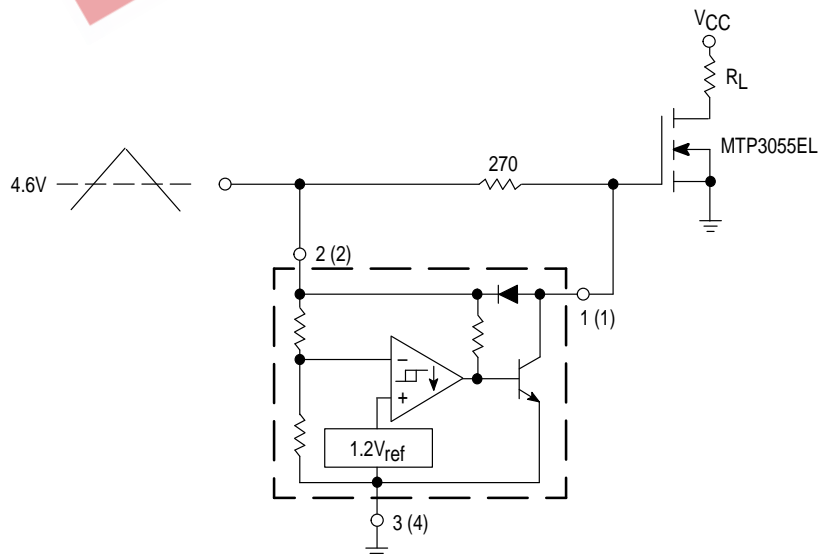

Figure 12. Low Power Switching Regulator



Test	Conditions	Results
Line Regulation	$V_{in} = 11.5 \text{ V to } 14.5 \text{ V}, I_O = 50 \text{ mA}$	35 mV
Load Regulation	$V_{in} = 12.6 \text{ V}, I_O = 0 \text{ mA to } 50 \text{ mA}$	12 mV
Output Ripple	$V_{in} = 12.6 \text{ V}, I_O = 50 \text{ mA}$	60 mVpp
Efficiency	$V_{in} = 12.6 \text{ V}, I_O = 50 \text{ mA}$	77%

Figure 13. MOSFET Low Voltage Gate Drive Protection



Overheating of the logic level power MOSFET due to insufficient gate voltage can be prevented with the above circuit. When the input signal is below the 4.6 V threshold of the MC34064, its output grounds the gate of the L<sup>2</sup> MOSFET.

# MC34064 MC33064

## OUTLINE DIMENSIONS

### P SUFFIX PLASTIC PACKAGE CASE 29-04 (TO-226AA) ISSUE AD

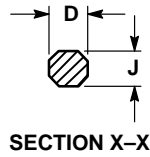
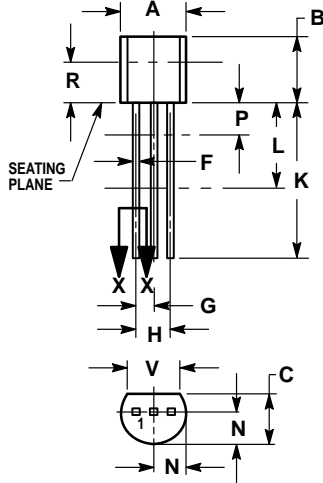

NOTES:

1. DIMENSIONING AND TOLERANCING PER ANSI Y14.5M, 1982.
2. CONTROLLING DIMENSION: INCH.
3. CONTOUR OF PACKAGE BEYOND DIMENSION R IS UNCONTROLLED.
4. DIMENSION F APPLIES BETWEEN P AND L. DIMENSION D AND J APPLY BETWEEN L AND K MINIMUM. LEAD DIMENSION IS UNCONTROLLED IN P AND BEYOND DIMENSION K MINIMUM.

DIM	INCHES		MILLIMETERS	
	MIN	MAX	MIN	MAX
A	0.175	0.205	4.45	5.20
B	0.170	0.210	4.32	5.33
C	0.125	0.165	3.18	4.19
D	0.016	0.022	0.41	0.55
F	0.016	0.019	0.41	0.48
G	0.045	0.055	1.15	1.39
H	0.095	0.105	2.42	2.66
J	0.015	0.020	0.39	0.50
K	0.500	—	12.70	—
L	0.250	—	6.35	—
N	0.080	0.105	2.04	2.66
P	—	0.100	—	2.54
R	0.115	—	2.93	—
V	0.135	—	3.43	—

### D SUFFIX PLASTIC PACKAGE CASE 751-05 (SO-8) ISSUE P

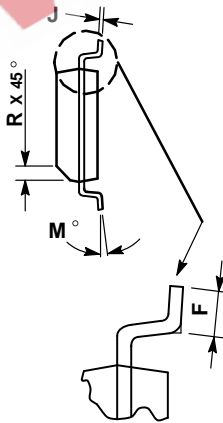
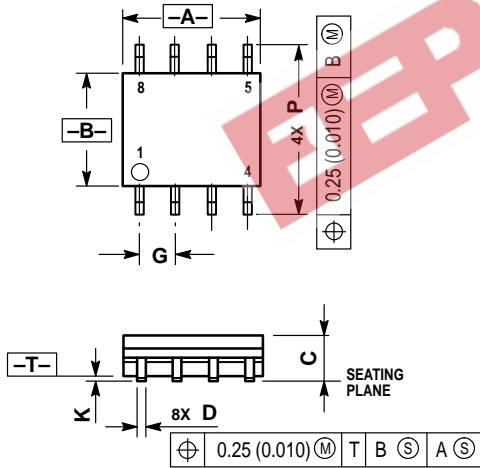

NOTES:

1. DIMENSIONS A AND B ARE DATUMS AND T IS A DATUM SURFACE.
2. DIMENSIONING AND TOLERANCING PER ANSI Y14.5M, 1982.
3. DIMENSIONS ARE IN MILLIMETER.
4. DIMENSION A AND B DO NOT INCLUDE MOLD PROTRUSION.
5. MAXIMUM MOLD PROTRUSION 0.15 PER SIDE.
6. DIMENSION D DOES NOT INCLUDE MOLD PROTRUSION. ALLOWABLE DAMBAR PROTRUSION SHALL BE 0.127 TOTAL IN EXCESS OF THE D DIMENSION AT MAXIMUM MATERIAL CONDITION.

DIM	MILLIMETERS	
	MIN	MAX
A	4.80	5.00
B	3.80	4.00
C	1.35	1.75
D	0.35	0.49
F	0.40	1.25
G	1.27 BSC	—
J	0.18	0.25
K	0.10	0.25
M	0°	7°
P	5.80	6.20
R	0.25	0.50

# MC34064 MC33064

## OUTLINE DIMENSIONS

DM SUFFIX  
 PLASTIC PACKAGE  
 CASE 846A-02  
 (Micro-8)  
 ISSUE B

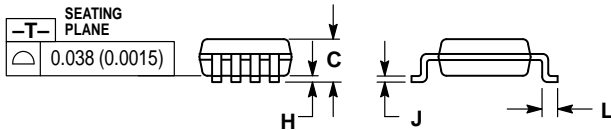
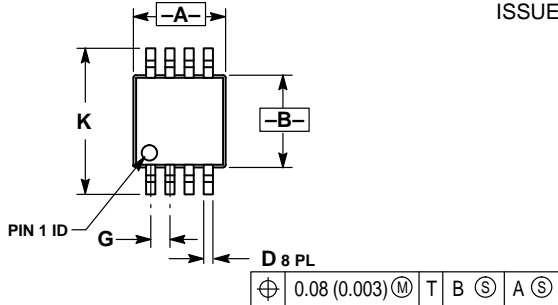

### NOTES:

1. DIMENSIONING AND TOLERANCING PER ANSI Y14.5M, 1982.
2. CONTROLLING DIMENSION: MILLIMETER.
3. DIMENSION A DOES NOT INCLUDE MOLD FLASH, PROTRUSIONS OR GATE BURRS. MOLD FLASH, PROTRUSIONS OR GATE BURRS SHALL NOT EXCEED 0.15 (0.006) PER SIDE.
4. DIMENSION D DOES NOT INCLUDE INTERLEAD FLASH OR PROTRUSION. INTERLEAD FLASH OR PROTRUSION SHALL NOT EXCEED 0.25 (0.010) PER SIDE.

DIM	MILLIMETERS		INCHES	
	MIN	MAX	MIN	MAX
A	2.90	3.10	0.114	0.122
B	2.90	3.10	0.114	0.122
C	—	1.10	—	0.043
D	0.25	0.40	0.010	0.016
G	0.65 BSC		0.026 BSC	
H	0.05	0.15	0.002	0.006
J	0.13	0.23	0.005	0.009
K	4.75	5.05	0.187	0.199
L	0.40	0.70	0.016	0.028

EPW.com.cn 电子产品世界

# MC34064 MC33064

EEPW 电子产品世界 .com.cn

Motorola reserves the right to make changes without further notice to any products herein. Motorola makes no warranty, representation or guarantee regarding the suitability of its products for any particular purpose, nor does Motorola assume any liability arising out of the application or use of any product or circuit, and specifically disclaims any and all liability, including without limitation consequential or incidental damages. "Typical" parameters which may be provided in Motorola data sheets and/or specifications can and do vary in different applications and actual performance may vary over time. All operating parameters, including "Typicals" must be validated for each customer application by customer's technical experts. Motorola does not convey any license under its patent rights nor the rights of others. Motorola products are not designed, intended, or authorized for use as components in systems intended for surgical implant into the body, or other applications intended to support or sustain life, or for any other application in which the failure of the Motorola product could create a situation where personal injury or death may occur. Should Buyer purchase or use Motorola products for any such unintended or unauthorized application, Buyer shall indemnify and hold Motorola and its officers, employees, subsidiaries, affiliates, and distributors harmless against all claims, costs, damages, and expenses, and reasonable attorney fees arising out of, directly or indirectly, any claim of personal injury or death associated with such unintended or unauthorized use, even if such claim alleges that Motorola was negligent regarding the design or manufacture of the part. Motorola and  are registered trademarks of Motorola, Inc. Motorola, Inc. is an Equal Opportunity/Affirmative Action Employer.

#### How to reach us:

**USA/EUROPE/Locations Not Listed:** Motorola Literature Distribution;  
P.O. Box 20912; Phoenix, Arizona 85036. 1-800-441-2447 or 602-303-5454

**MFAX:** RMFAX0@email.sps.mot.com – TOUCHTONE 602-244-6609  
**INTERNET:** <http://Design-NET.com>

**JAPAN:** Nippon Motorola Ltd.; Tatsumi-SPD-JLDC, 6F Seibu-Butsuryu-Center,  
3-14-2 Tatsumi Koto-Ku, Tokyo 135, Japan. 03-81-3521-8315

**ASIA/PACIFIC:** Motorola Semiconductors H.K. Ltd.; 8B Tai Ping Industrial Park,  
51 Ting Kok Road, Tai Po, N.T., Hong Kong. 852-26629298



**MOTOROLA**



MC34064/D

