

Dual Precision Monostable Multivibrator (Retriggerable, Resettable)

The MC54/74HC4538A is identical in pinout to the MC14538B. The device inputs are compatible with standard CMOS outputs; with pullup resistors, they are compatible with LSTTL outputs.

This dual monostable multivibrator may be triggered by either the positive or the negative edge of an input pulse, and produces a precision output pulse over a wide range of pulse widths. Because the device has conditioned trigger inputs, there are no trigger-input rise and fall time restrictions. The output pulse width is determined by the external timing components, R_X and C_X . The device has a reset function which forces the Q output low and the \overline{Q} output high, regardless of the state of the output pulse circuitry.

- Unlimited Rise and Fall Times Allowed on the Trigger Inputs
- Output Pulse is Independent of the Trigger Pulse Width
- $\pm 10\%$ Guaranteed Pulse Width Variation from Part to Part (Using the Same Test Jig)
- Output Drive Capability: 10 LSTTL Loads
- Outputs Directly Interface to CMOS, NMOS and TTL
- Operating Voltage Range: 3.0 to 6.0 V
- Low Input Current: 1.0 μ A
- High Noise Immunity Characteristic of CMOS Devices
- In Compliance with the Requirements Defined by JEDEC Standard No. 7A
- Chip Complexity: 145 FETs or 36 Equivalent Gates

LOGIC DIAGRAM

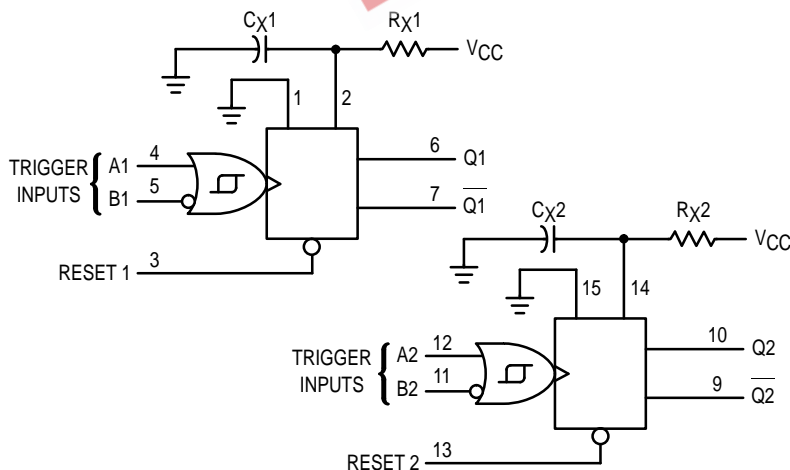

PIN 16 = V_{CC}
PIN 8 = GND
 R_X AND C_X ARE EXTERNAL COMPONENTS
PIN 1 AND PIN 15 MUST BE HARD WIRED TO GND

MC54/74HC4538A

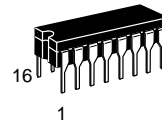

J SUFFIX
CERAMIC PACKAGE
CASE 620-10

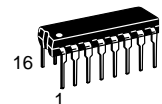

N SUFFIX
PLASTIC PACKAGE
CASE 648-08

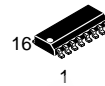

D SUFFIX
SOIC PACKAGE
CASE 751B-05

ORDERING INFORMATION

MC54HCXXXAJ	Ceramic
MC74HCXXXAN	Plastic
MC74HCXXXAD	SOIC

PIN ASSIGNMENT

GND	1	16	V_{CC}
C_X1/R_X1	2	15	GND
RESET 1	3	14	C_X2/R_X2
A1	4	13	RESET 2
B1	5	12	A2
Q_1	6	11	B2
$\overline{Q_1}$	7	10	Q_2
GND	8	9	$\overline{Q_2}$

FUNCTION TABLE

Inputs		Outputs		
Reset	A	B	Q	\overline{Q}
H	H	H		
H	L	L		
H	X	L	Not Triggered	Not Triggered
H	H	X	Not Triggered	Not Triggered
H	L, H,	H	Not Triggered	Not Triggered
H	L	L, H,	Not Triggered	Not Triggered
L	X	X	L	H
	X	X	Not Triggered	Not Triggered



MC54/74HC4538A

MAXIMUM RATINGS*

Symbol	Parameter	Value	Unit
V _{CC}	DC Supply Voltage (Referenced to GND)	- 0.5 to + 7.0	V
V _{in}	DC Input Voltage (Referenced to GND)	- 1.5 to V _{CC} + 1.5	V
V _{out}	DC Output Voltage (Referenced to GND)	- 0.5 to V _{CC} + 0.5	
I _{in}	DC Input Current, per Pin A, B, Reset C _x , R _x	± 20 ± 30	mA
I _{out}	DC Output Current, per Pin	± 25	mA
I _{CC}	DC Supply Current, V _{CC} and GND Pins	± 50	mA
P _D	Power Dissipation in Still Air, Plastic or Ceramic DIP† SOIC Package†	750 500	mW
T _{stg}	Storage Temperature	- 65 to + 150	°C
T _L	Lead Temperature, 1 mm from Case for 10 Seconds (Plastic DIP or SOIC Package) (Ceramic DIP)	260 300	°C

This device contains protection circuitry to guard against damage due to high static voltages or electric fields. However, precautions must be taken to avoid applications of any voltage higher than maximum rated voltages to this high-impedance circuit. For proper operation, V_{in} and V_{out} should be constrained to the range GND ≤ (V_{in} or V_{out}) ≤ V_{CC}. Unused inputs must always be tied to an appropriate logic voltage level (e.g., either GND or V_{CC}). Unused outputs must be left open.

* Maximum Ratings are those values beyond which damage to the device may occur. Functional operation should be restricted to the Recommended Operating Conditions.

† Derating — Plastic DIP: - 10 mW/°C from 65° to 125°C
Ceramic DIP: - 10 mW/°C from 100° to 125°C
SOIC Package: - 7 mW/°C from 65° to 125°C

For high frequency or heavy load considerations, see Chapter 2 of the Motorola High-Speed CMOS Data Book (DL129/D).

RECOMMENDED OPERATING CONDITIONS

Symbol	Parameter	Min	Max	Unit
V _{CC}	DC Supply Voltage (Referenced to GND)	3.0**	6.0	V
V _{in} , V _{out}	DC Input Voltage, Output Voltage (Referenced to GND)	0	V _{CC}	V
T _A	Operating Temperature, All Package Types	- 55	+ 125	°C
t _r , t _f	Input Rise and Fall Time (Figure 7)	V _{CC} = 2.0 V 0 V _{CC} = 4.5 V 0 V _{CC} = 6.0 V	1000 500 400	ns
	A or B (Figure 5)	—	No Limit	
R _x	External Timing Resistor	V _{CC} < 4.5 V 2.0 V _{CC} ≥ 4.5 V	*	kΩ
C _x	External Timing Capacitor	0	*	μF

* The maximum allowable values of R_x and C_x are a function of the leakage of capacitor C_x, the leakage of the HC4538A, and leakage due to board layout and surface resistance. For most applications, C_x/R_x should be limited to a maximum value of 10 μF/1.0 MΩ. Values of C_x > 1.0 μF may cause a problem during power down (see Power Down Considerations). Susceptibility to externally induced noise signals may occur for R_x > 1.0 MΩ.

** The HC4538A will function at 2.0 V but for optimum pulse width stability, V_{CC} should be above 3.0 V.

NOTE: Information on typical parametric values can be found in Chapter 2 of the Motorola High-Speed CMOS Data Book (DL129/D).

DC CHARACTERISTICS FOR THE MC54/74HC4538A

Symbol	Parameter	Test Conditions	V _{CC} Volts	Guaranteed Limits						Unit
				– 55 to 25°C		≤ 85°C		≤ 125°C		
				Min	Max	Min	Max	Min	Max	
V _{IH}	Minimum High–Level Input Voltage	V _{out} = 0.1 V or V _{CC} – 0.1 V I _{out} ≤ 20 μA	2.0	1.5		1.5		1.5		V
			4.5	3.15		3.15		3.15		
			6.0	4.2		4.2		4.2		
V _{IL}	Maximum Low–Level Input Voltage	V _{out} = 0.1 V or V _{CC} – 0.1 V I _{out} ≤ 20 μA	2.0		0.5		0.5		0.5	V
			4.5		1.35		1.35		1.35	
			6.0		1.8		1.8		1.8	
V _{OH}	Minimum High–Level Output Voltage	V _{in} = V _{IH} or V _{IL} I _{out} ≤ 20 μA	2.0	1.9		1.9		1.9		V
			4.5	4.4		4.4		4.4		
		6.0	5.9		5.9		5.9			
		V _{in} = V _{IH} or V _{IL} I _{out} ≤ –4.0 mA I _{out} ≤ –5.2 mA	4.5	3.98		3.84		3.7		
6.0	5.48			5.34		5.2				
V _{OL}	Maximum Low–Level Output Voltage	V _{in} = V _{IH} or V _{IL} I _{out} ≤ 20 μA	2.0		0.1		0.1		0.1	V
			4.5		0.1		0.1		0.1	
		6.0		0.1		0.1		0.1		
		V _{in} = V _{IH} or V _{IL} I _{out} ≤ 4.0 mA I _{out} ≤ 5.2 mA	4.5		0.26		0.33		0.4	
6.0			0.26		0.33		0.4			
I _{in}	Maximum Input Leakage Current (A, B, Reset)	V _{in} = V _{CC} or GND	6.0		± 0.1		± 1.0		± 1.0	μA
I _{in}	Maximum Input Leakage Current (R _x , C _x)	V _{in} = V _{CC} or GND	6.0		± 50		± 500		± 500	nA
I _{CC}	Maximum Quiescent Supply Current (per package) Standby State	V _{in} = V _{CC} or GND Q1 and Q2 = Low I _{out} = 0 μA	6.0		130		220		350	μA
I _{CC}	Maximum Supply Current (per package) Active State	V _{in} = V _{CC} or GND Q1 and Q2 = High I _{out} = 0 μA Pins 2 and 14 = 0.5 V _{CC}	6.0	25°C		– 45°C to 85°C		– 55°C to 125°C		μA
					400		600		800	

MC54/74HC4538A

AC CHARACTERISTICS FOR THE MC54/74HC4538A ($C_L = 50$ pF, Input $t_r = t_f = 6.0$ ns)

Symbol	Parameter	VCC Volts	Guaranteed Limits						Unit
			- 55 to 25°C		≤ 85°C		≤ 125°C		
			Min	Max	Min	Max	Min	Max	
t _{PLH}	Maximum Propagation Delay Input A or B to Q (Figures 6 and 8)	2.0		175		220		265	ns
		4.5		35		44		53	
		6.0		30		37		45	
t _{PHL}	Maximum Propagation Delay Input A or B to NQ (Figures 6 and 8)	2.0		195		245		295	ns
		4.5		39		49		59	
		6.0		33		42		50	
t _{PHL}	Maximum Propagation Delay Reset to Q (Figures 7 and 8)	2.0		175		220		265	ns
		4.5		35		44		53	
		6.0		30		37		45	
t _{PLH}	Maximum Propagation Delay Reset to NQ (Figures 7 and 8)	2.0		175		220		265	ns
		4.5		35		44		53	
		6.0		30		37		45	
t _{TLH} t _{THL}	Maximum Output Transition Time, Any Output (Figures 7 and 8)	2.0		75		95		110	ns
		4.5		15		19		22	
		6.0		13		16		19	
C _{in}	Maximum Input Capacitance (A, B, Reset) (C _x , R _x)	—		10		10		10	pF
				25		25		25	

NOTE: For propagation delays with loads other than 50 pF, and information on typical parametric values, see Chapter 2 of the Motorola High-Speed CMOS Data Book (DL129/D).

CPD	Power Dissipation Capacitance (Per Multivibrator)*	Typical @ 25°C, VCC = 5.0 V		pF
		150		

* Used to determine the no-load dynamic power consumption: $P_D = C_{PD} V_{CC}^2 f + I_{CC} V_{CC}$. For load considerations, see Chapter 2 of the Motorola High-Speed CMOS Data Book (DL129/D).

TIMING CHARACTERISTICS FOR THE MC54/74HC4538A (Input $t_r = t_f = 6.0$ ns)

Symbol	Parameter	VCC Volts	Guaranteed Limits						Unit
			- 55 to 25°C		≤ 85°C		≤ 125°C		
			Min	Max	Min	Max	Min	Max	
t _{rec}	Minimum Recovery Time, Inactive to A or B (Figure 7)	2.0	0		0		0		ns
		4.5	0		0		0		
		6.0	0		0		0		
t _w	Minimum Pulse Width, Input A or B (Figure 6)	2.0	60		75		90		ns
		4.5	12		15		18		
		6.0	10		13		15		
t _w	Minimum Pulse Width, Reset (Figure 7)	2.0	60		75		90		ns
		4.5	12		15		18		
		6.0	10		13		15		
t _r , t _f	Maximum Input Rise and Fall Times, Reset (Figure 7)	2.0		1000		1000		1000	ns
		4.5		500		500		500	
		6.0		400		400		400	
	A or B (Figure 7)	2.0	No Limit						
		4.5							
		6.0							

OUTPUT PULSE WIDTH CHARACTERISTICS ($C_L = 50 \text{ pF}$)^t

Symbol	Parameter	Conditions		Guaranteed Limits						Unit
		Timing Components	V_{CC} Volts	- 55 to 25°C		≤ 85°C		≤ 125°C		
				Min	Max	Min	Max	Min	Max	
τ	Output Pulse Width* (Figures 6 and 8)	$R_X = 10 \text{ k}\Omega, C_X = 0.1 \mu\text{F}$	5.0	0.63	0.77	0.6	0.8	0.59	0.81	ms
—	Pulse Width Match Between Circuits in the same Package	—	—	± 5.0						%
—	Pulse Width Match Variation (Part to Part)	—	—	± 10						%

* For output pulse widths greater than 100 μs , typically $\tau = kR_X C_X$, where the value of k may be found in Figure 1.

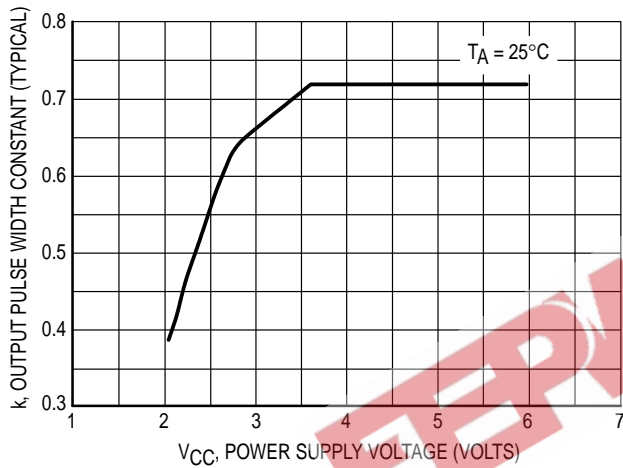

Figure 1. Typical Output Pulse Width Constant, k, versus Supply Voltage
(For output pulse widths > 100 μs : $\tau = kR_X C_X$)

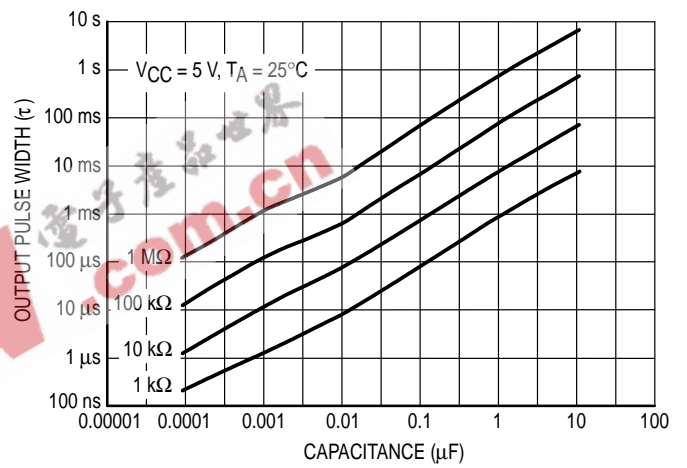

Figure 2. Output Pulse Width versus Timing Capacitance

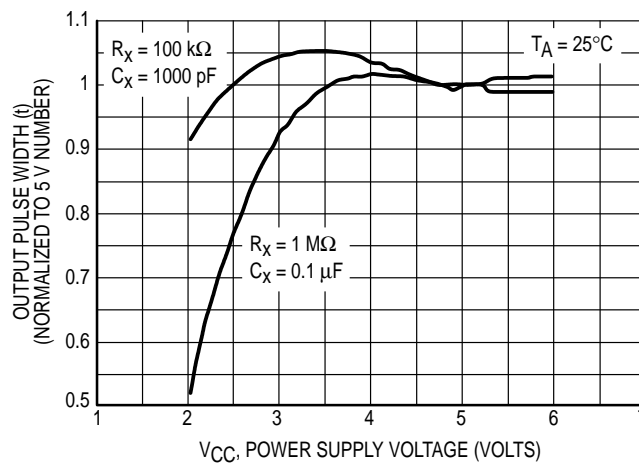

Figure 3. Normalized Output Pulse Width versus Power Supply Voltage

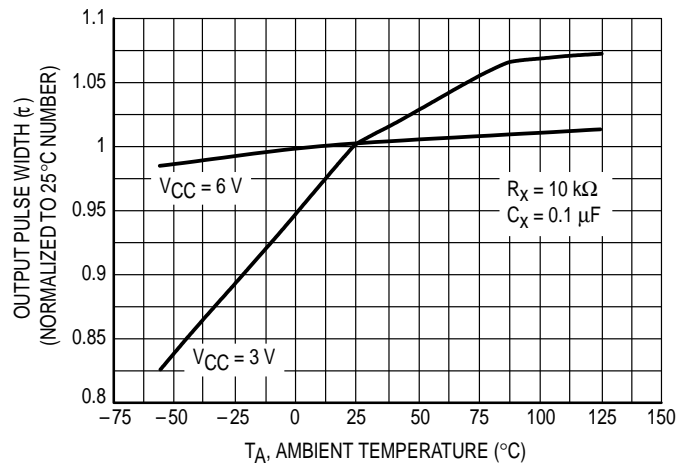

Figure 4. Normalized Output Pulse Width versus Power Supply Voltage

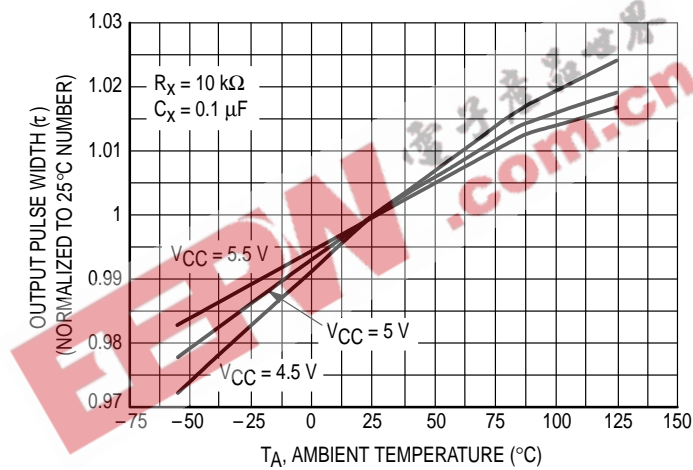

Figure 5. Normalized Output Pulse Width versus Power Supply Voltage

SWITCHING WAVEFORMS

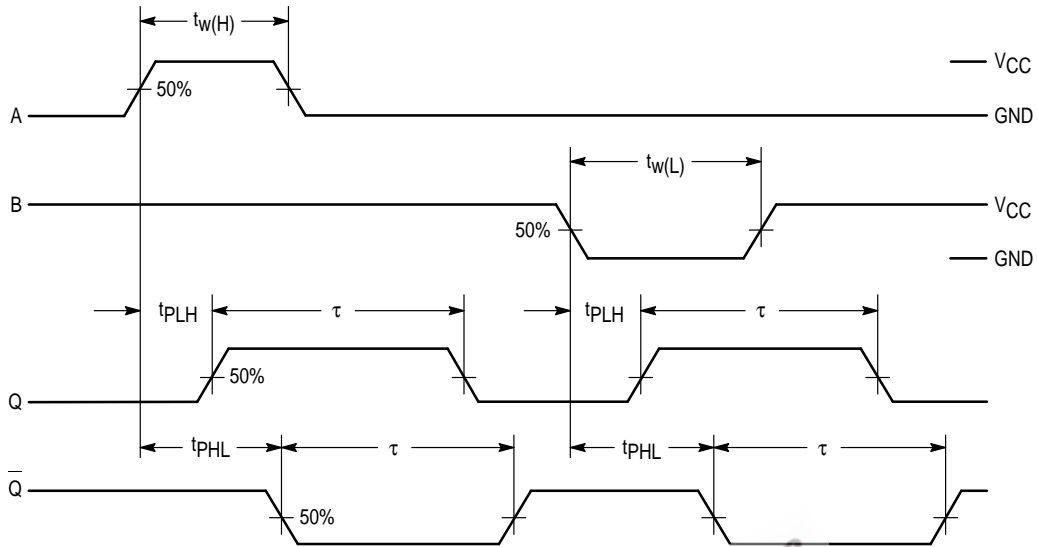

Figure 6.

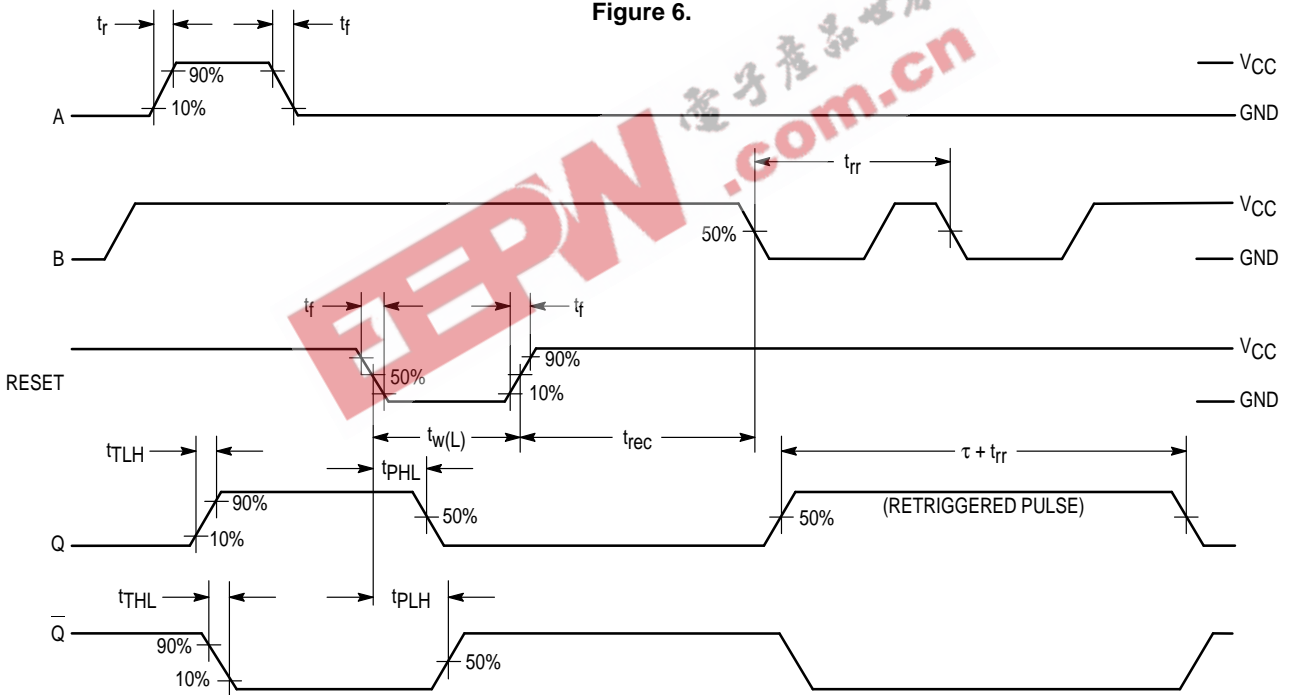
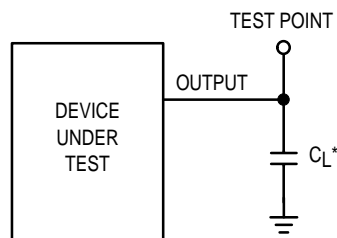

Figure 7.



* Includes all probe and jig capacitance

Figure 8. Test Circuit

PIN DESCRIPTIONS

INPUTS

A1, A2 (Pins 4, 12)

Positive-edge trigger inputs. A rising-edge signal on either of these pins triggers the corresponding multivibrator when there is a high level on the B1 or B2 input.

B1, B2 (Pins 5, 11)

Negative-edge trigger inputs. A falling-edge signal on either of these pins triggers the corresponding multivibrator when there is a low level on the A1 or A2 input.

Reset 1, Reset 2 (Pins 3, 13)

Reset inputs (active low). When a low level is applied to one of these pins, the Q output of the corresponding multivibrator is reset to a low level and the Q output is set to a high level.

Cx1/Rx1 and Cx2/Rx2 (Pins 2 and 14)

External timing components. These pins are tied to the common points of the external timing resistors and capaci-

tors (see the Block Diagram). Polystyrene capacitors are recommended for optimum pulse width control. Electrolytic capacitors are not recommended due to high leakages associated with these type capacitors.

GND (Pins 1 and 15)

External ground. The external timing capacitors discharge to ground through these pins.

OUTPUTS

Q1, Q2 (Pins 6, 10)

Noninverted monostable outputs. These pins (normally low) pulse high when the multivibrator is triggered at either the A or the B input. The width of the pulse is determined by the external timing components, Rx and Cx.

$\overline{Q1}, \overline{Q2}$ (Pins 7, 9)

Inverted monostable outputs. These pins (normally high) pulse low when the multivibrator is triggered at either the A or the B input. These outputs are the inverse of Q1 and Q2.

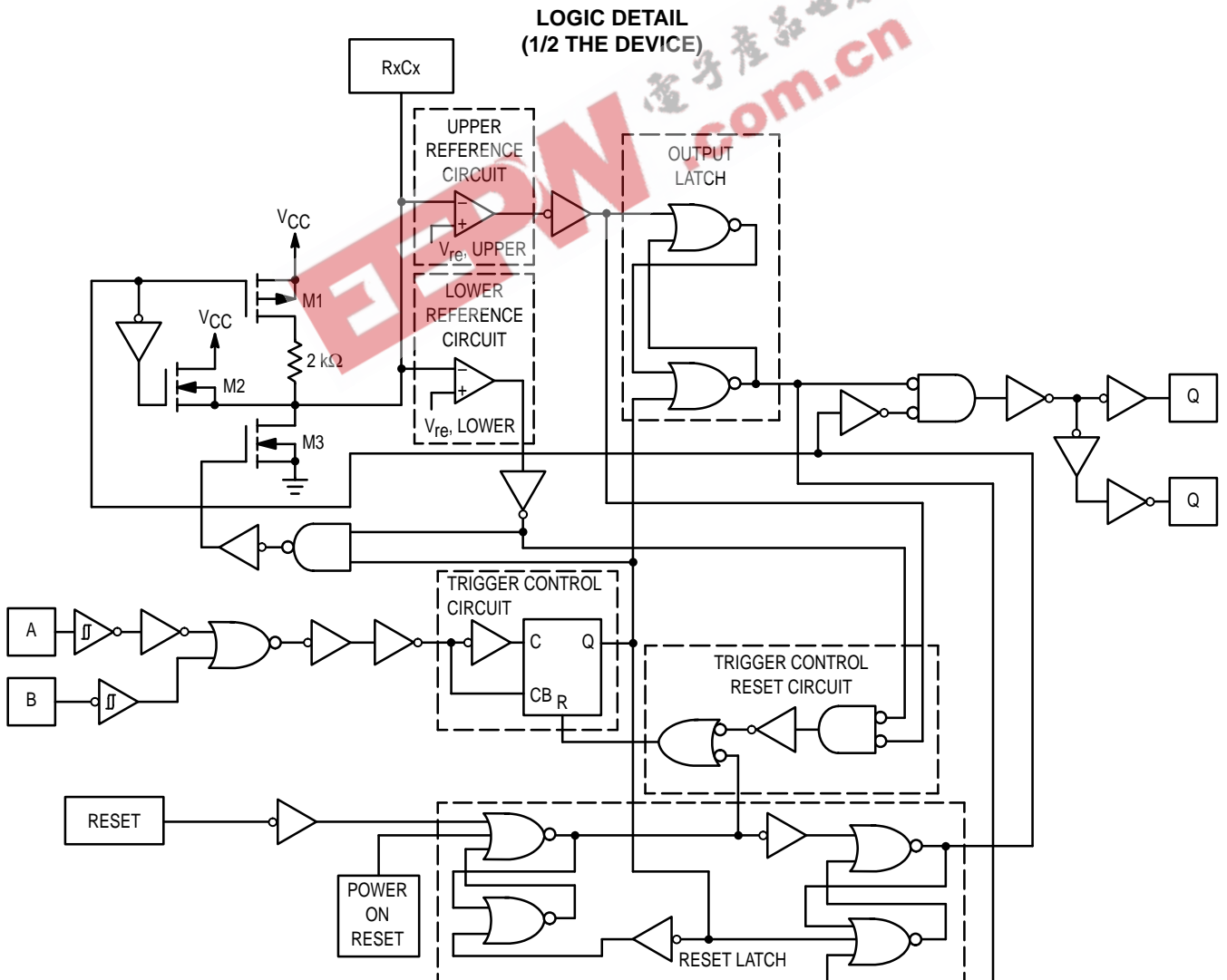

Figure 9.

CIRCUIT OPERATION

Figure 12 shows the HC4538A configured in the retriggerable mode. Briefly, the device operates as follows (refer to Figure 10): In the quiescent state, the external timing capacitor, C_X , is charged to V_{CC} . When a trigger occurs, the Q output goes high and C_X discharges quickly to the lower reference voltage ($V_{ref\ Lower} \approx 1/3 V_{CC}$). C_X then charges, through R_X , back up to the upper reference voltage ($V_{ref\ Upper} \approx 2/3 V_{CC}$), at which point the one-shot has timed out and the Q output goes low.

The following, more detailed description of the circuit operation refers to both the logic detail (Figure 9) and the timing diagram (Figure 10).

QUIESCENT STATE

In the quiescent state, before an input trigger appears, the output latch is high and the reset latch is high (#1 in Figure 10). Thus the Q output (pin 6 or 10) of the monostable multivibrator is low (#2, Figure 10).

The output of the trigger-control circuit is low (#3), and transistors M1, M2, and M3 are turned off. The external timing capacitor, C_X , is charged to V_{CC} (#4), and both the upper and lower reference circuit has a low output (#5).

In addition, the output of the trigger-control reset circuit is low.

TRIGGER OPERATION

The HC4538A is triggered by either a rising-edge signal at input A (#7) or a falling-edge signal at input B (#8), with the unused trigger input and the Reset input held at the voltage levels shown in the Function Table. Either trigger signal will cause the output of the trigger-control circuit to go high (#9).

The trigger-control circuit going high simultaneously initiates two events. First, the output latch goes low, thus taking the Q output of the HC4538A to a high state (#10). Second, transistor M3 is turned on, which allows the external timing capacitor, C_X , to rapidly discharge toward ground (#11). (Note that the voltage across C_X appears at the input of both the upper and lower reference circuit comparators).

When C_X discharges to the reference voltage of the lower reference circuit (#12), the outputs of both reference circuits will be high (#13). The trigger-control reset circuit goes high, resetting the trigger-control circuit flip-flop to a low state (#14). This turns transistor M3 off again, allowing C_X to begin to charge back up toward V_{CC} , with a time constant $t = R_X C_X$ (#15). Once the voltage across C_X charges to above the lower reference voltage, the lower reference circuit will go low allowing the monostable multivibrator to be retriggered.

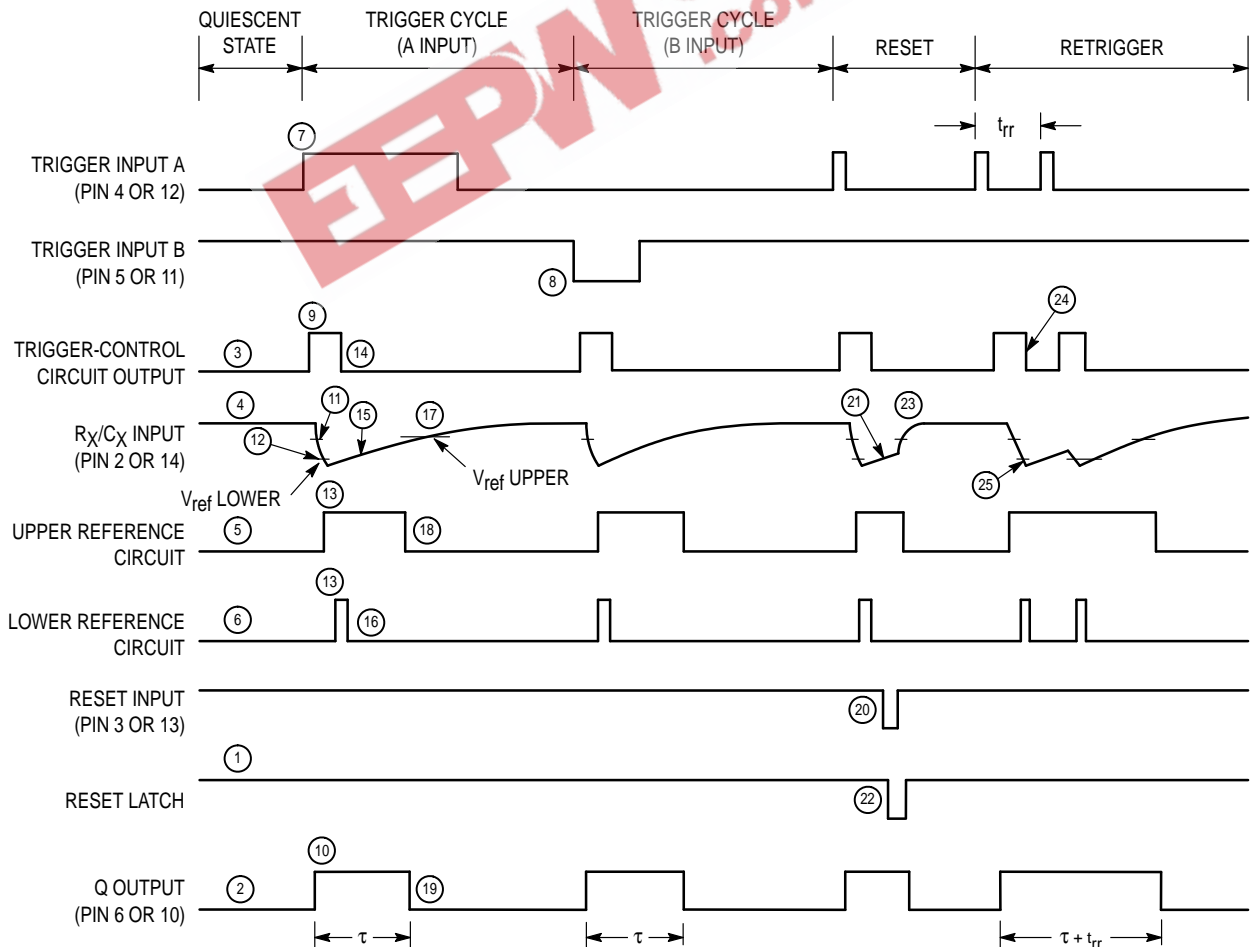

Figure 10. Timing Diagram

MC54/74HC4538A

When C_X charges up to the reference voltage of the upper reference circuit (#17), the output of the upper reference circuit goes low (#18). This causes the output latch to toggle, taking the Q output of the HC4538A to a low state (#19), and completing the time-out cycle.

POWER-DOWN CONSIDERATIONS

Large values of C_X may cause problems when powering down the HC4538A because of the amount of energy stored in the capacitor. When a system containing this device is powered down, the capacitor may discharge from V_{CC} through the input protection diodes at pin 2 or pin 14. Current through the protection diodes must be limited to 30 mA; therefore, the turn-off time of the V_{CC} power supply must not be faster than $t = V_{CC} \cdot C_X / (30 \text{ mA})$. For example, if $V_{CC} = 5.0 \text{ V}$ and $C_X = 15 \mu\text{F}$, the V_{CC} supply must turn off no faster than $t = (5.0 \text{ V}) \cdot (15 \mu\text{F}) / 30 \text{ mA} = 2.5 \text{ ms}$. This is usually not a problem because power supplies are heavily filtered and cannot discharge at this rate.

When a more rapid decrease of V_{CC} to zero volts occurs, the HC4538A may sustain damage. To avoid this possibility, use an external damping diode, D_X , connected as shown in Figure 11. Best results can be achieved if diode D_X is chosen to be a germanium or Schottky type diode able to withstand large current surges.

RESET AND POWER ON RESET OPERATION

A low voltage applied to the Reset pin always forces the Q output of the HC4538A to a low state.

The timing diagram illustrates the case in which reset occurs (#20) while C_X is charging up toward the reference voltage of the upper reference circuit (#21). When a reset

occurs, the output of the reset latch goes low (#22), turning on transistor M1. Thus C_X is allowed to quickly charge up to V_{CC} (#23) to await the next trigger signal.

On power up of the HC4538A the power-on reset circuit will be high causing a reset condition. This will prevent the trigger-control circuit from accepting a trigger input during this state. The HC4538A's Q outputs are low and the Q not outputs are high.

RETRIGGER OPERATION

When used in the retriggerable mode (Figure 12), the HC4538A may be retriggered during timing out of the output pulse at any time after the trigger-control circuit flip-flop has been reset (#24), and the voltage across C_X is above the lower reference voltage. As long as the C_X voltage is below the lower reference voltage, the reset of the flip-flop is high, disabling any trigger pulse. This prevents M3 from turning on during this period resulting in an output pulse width that is predictable.

The amount of undershoot voltage on $R_X C_X$ during the trigger mode is a function of loop delay, M3 conductivity, and V_{DD} . Minimum retrigger time, t_{rr} (Figure 7), is a function of 1) time to discharge $R_X C_X$ from V_{DD} to lower reference voltage ($T_{\text{discharge}}$); 2) loop delay (T_{delay}); 3) time to charge $R_X C_X$ from the undershoot voltage back to the lower reference voltage (T_{charge}).

Figure 13 shows the device configured in the non-retriggerable mode.

An Application Note (AN1558/D) titled *Characterization of Retrigger Time in the HC4538A Dual Precision Monostable Multivibrator* is being prepared. Please consult the factory for its availability.

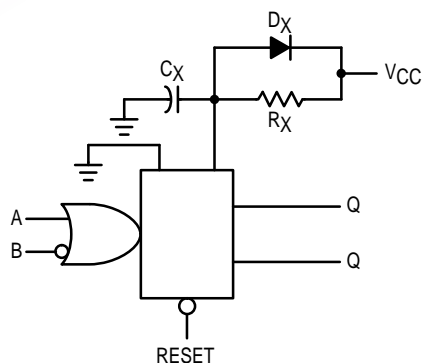

Figure 11. Discharge Protection During Power Down

TYPICAL APPLICATIONS

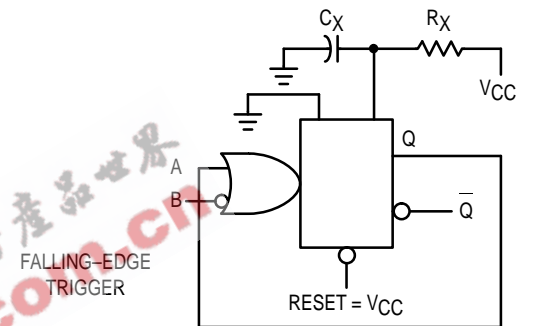
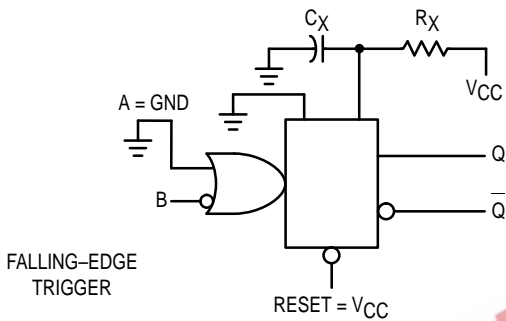
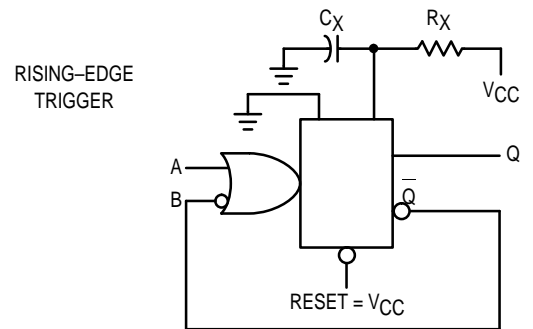
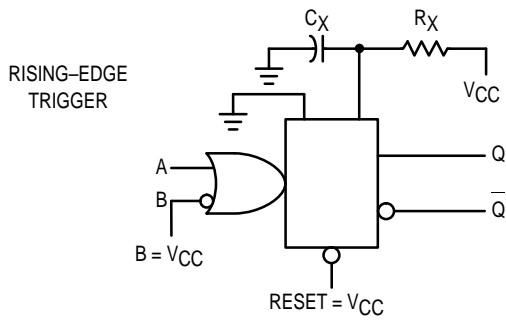
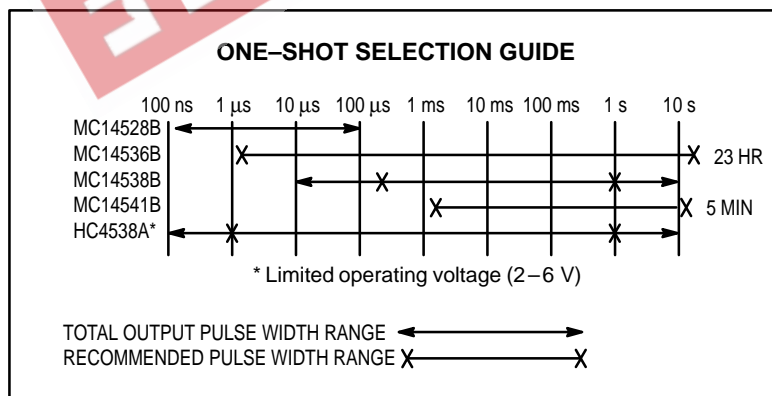

Figure 12. Retriggerable Monostable Circuitry

Figure 13. Non-retriggerable Monostable Circuitry



OUTLINE DIMENSIONS

J SUFFIX
CERAMIC PACKAGE
CASE 620-10
ISSUE V

NOTES:

1. DIMENSIONING AND TOLERANCING PER ANSI Y14.5M, 1982.
2. CONTROLLING DIMENSION: INCH.
3. DIMENSION L TO CENTER OF LEAD WHEN FORMED PARALLEL.
4. DIM F MAY NARROW TO 0.76 (0.030) WHERE THE LEAD ENTERS THE CERAMIC BODY.

DIM	INCHES		MILLIMETERS	
	MIN	MAX	MIN	MAX
A	0.750	0.785	19.05	19.93
B	0.240	0.295	6.10	7.49
C	—	0.200	—	5.08
D	0.015	0.020	0.39	0.50
E	0.050 BSC		1.27 BSC	
F	0.055	0.065	1.40	1.65
G	0.100 BSC		2.54 BSC	
J	0.008	0.015	0.21	0.38
K	0.125	0.170	3.18	4.31
L	0.300 BSC		7.62 BSC	
M	0°	15°	0°	15°
N	0.020	0.040	0.51	1.01

D 16 PL $\oplus 0.25 (0.010) \text{ (M) T A (S)}$

J 16 PL $\oplus 0.25 (0.010) \text{ (M) T B (S)}$

N SUFFIX
PLASTIC PACKAGE
CASE 648-08
ISSUE R

NOTES:

1. DIMENSIONING AND TOLERANCING PER ANSI Y14.5M, 1982.
2. CONTROLLING DIMENSION: INCH.
3. DIMENSION L TO CENTER OF LEADS WHEN FORMED PARALLEL.
4. DIMENSION B DOES NOT INCLUDE MOLD FLASH.
5. ROUNDED CORNERS OPTIONAL.

DIM	INCHES		MILLIMETERS	
	MIN	MAX	MIN	MAX
A	0.740	0.770	18.80	19.55
B	0.250	0.270	6.35	6.85
C	0.145	0.175	3.69	4.44
D	0.015	0.021	0.39	0.53
F	0.040	0.070	1.02	1.77
G	0.100 BSC		2.54 BSC	
H	0.050 BSC		1.27 BSC	
J	0.008	0.015	0.21	0.38
K	0.110	0.130	2.80	3.30
L	0.295	0.305	7.50	7.74
M	0°	10°	0°	10°
S	0.020	0.040	0.51	1.01

D 16 PL $\oplus 0.25 (0.010) \text{ (M) T A (M)}$

D SUFFIX
PLASTIC SOIC PACKAGE
CASE 751B-05
ISSUE J

NOTES:

1. DIMENSIONING AND TOLERANCING PER ANSI Y14.5M, 1982.
2. CONTROLLING DIMENSION: MILLIMETER.
3. DIMENSIONS A AND B DO NOT INCLUDE MOLD PROTRUSION.
4. MAXIMUM MOLD PROTRUSION 0.15 (0.006) PER SIDE.
5. DIMENSION D DOES NOT INCLUDE DAMBAR PROTRUSION. ALLOWABLE DAMBAR PROTRUSION SHALL BE 0.127 (0.005) TOTAL IN EXCESS OF THE D DIMENSION AT MAXIMUM MATERIAL CONDITION.

DIM	MILLIMETERS		INCHES	
	MIN	MAX	MIN	MAX
A	9.80	10.00	0.386	0.393
B	3.80	4.00	0.150	0.157
C	1.35	1.75	0.054	0.068
D	0.35	0.49	0.014	0.019
F	0.40	1.25	0.016	0.049
G	1.27 BSC		0.050 BSC	
J	0.19	0.25	0.008	0.009
K	0.10	0.25	0.004	0.009
M	0°	7°	0°	7°
P	5.80	6.20	0.229	0.244
R	0.25	0.50	0.010	0.019

D 16 PL $\oplus 0.25 (0.010) \text{ (M) T B (S) A (S)}$

EEPW 电子产品世界
 .com.cn

Motorola reserves the right to make changes without further notice to any products herein. Motorola makes no warranty, representation or guarantee regarding the suitability of its products for any particular purpose, nor does Motorola assume any liability arising out of the application or use of any product or circuit, and specifically disclaims any and all liability, including without limitation consequential or incidental damages. "Typical" parameters can and do vary in different applications. All operating parameters, including "Typicals" must be validated for each customer application by customer's technical experts. Motorola does not convey any license under its patent rights nor the rights of others. Motorola products are not designed, intended, or authorized for use as components in systems intended for surgical implant into the body, or other applications intended to support or sustain life, or for any other application in which the failure of the Motorola product could create a situation where personal injury or death may occur. Should Buyer purchase or use Motorola products for any such unintended or unauthorized application, Buyer shall indemnify and hold Motorola and its officers, employees, subsidiaries, affiliates, and distributors harmless against all claims, costs, damages, and expenses, and reasonable attorney fees arising out of, directly or indirectly, any claim of personal injury or death associated with such unintended or unauthorized use, even if such claim alleges that Motorola was negligent regarding the design or manufacture of the part. Motorola and  are registered trademarks of Motorola, Inc. Motorola, Inc. is an Equal Opportunity/Affirmative Action Employer.

How to reach us:

USA/EUROPE: Motorola Literature Distribution;
 P.O. Box 20912; Phoenix, Arizona 85036. 1-800-441-2447

JAPAN: Nippon Motorola Ltd.; Tatsumi-SPD-JLDC, Toshikatsu Otsuki,
 6F Seibu-Butsuryu-Center, 3-14-2 Tatsumi Koto-Ku, Tokyo 135, Japan. 03-3521-8315

MFAX: RMFAX0@email.sps.mot.com -TOUCHTONE (602) 244-6609
INTERNET: <http://Design-NET.com>

HONG KONG: Motorola Semiconductors H.K. Ltd.; 8B Tai Ping Industrial Park,
 51 Ting Kok Road, Tai Po, N.T., Hong Kong. 852-26629298



◇ CODELINE

MC54/74HC4538A/D

