

MC68HC08JL3

Data Sheet

M68HC08
Microcontrollers

EEPW 电子产品世界
.com.cn

Rev. 4.1
MC68HC08JL3/H
July 14, 2005

freescale.com



EEPW 电子产品世界
.com.cn

List of Sections

Section 1. General Description	21
Section 2. Memory	27
Section 3. Random-Access Memory (RAM)	37
Section 4. Read-Only Memory (ROM)	39
Section 5. Configuration Register (CONFIG)	41
Section 6. Central Processor Unit (CPU)	45
Section 7. System Integration Module (SIM)	65
Section 8. Oscillator (OSC)	89
Section 9. Monitor ROM (MON)	95
Section 10. Timer Interface Module (TIM)	105
Section 11. Analog-to-Digital Converter (ADC)	127
Section 12. I/O Ports	137
Section 13. External Interrupt (IRQ)	149
Section 14. Keyboard Interrupt Module (KBI)	155
Section 15. Computer Operating Properly (COP)	163
Section 16. Low Voltage Inhibit (LVI)	169
Section 17. Break Module (BREAK)	173
Section 18. Electrical Specifications	181
Section 19. Mechanical Specifications	193



EEPW 电子产品世界
.com.cn

Table of Contents

Section 1. General Description

1.1	Contents	21
1.2	Introduction	21
1.3	Features	22
1.4	MCU Block Diagram	23
1.5	Pin Assignments	25
1.6	Pin Functions	26

Section 2. Memory

2.1	Contents	27
2.2	Introduction	27
2.3	I/O Section	29
2.4	Monitor ROM	29

Section 3. Random-Access Memory (RAM)

3.1	Contents	37
3.2	Introduction	37
3.3	Functional Description	37

Section 4. Read-Only Memory (ROM)

4.1	Contents	39
4.2	Introduction	39
4.3	Functional Description	39

Section 5. Configuration Register (CONFIG)

5.1	Contents	41
5.2	Introduction	41
5.3	Functional Description	42

Section 6. Central Processor Unit (CPU)

6.1	Contents	45
6.2	Introduction	45
6.3	Features	46
6.4	CPU Registers	46
6.4.1	Accumulator	47
6.4.2	Index Register	48
6.4.3	Stack Pointer	48
6.4.4	Program Counter	49
6.4.5	Condition Code Register	49
6.5	Arithmetic/Logic Unit (ALU)	52
6.6	Low-Power Modes	52
6.6.1	Wait Mode	52
6.6.2	Stop Mode	53
6.7	CPU During Break Interrupts	53
6.8	Instruction Set Summary	53
6.9	Opcode Map	53

Section 7. System Integration Module (SIM)

7.1	Contents	65
7.2	Introduction	66
7.3	SIM Bus Clock Control and Generation	69
7.3.1	Bus Timing	69
7.3.2	Clock Start-Up from POR	69
7.3.3	Clocks in Stop Mode and Wait Mode	69

7.4	Reset and System Initialization	70
7.4.1	External Pin Reset	70
7.4.2	Active Resets from Internal Sources	71
7.4.2.1	Power-On Reset	72
7.4.2.2	Computer Operating Properly (COP) Reset	73
7.4.2.3	Illegal Opcode Reset	73
7.4.2.4	Illegal Address Reset	73
7.4.2.5	LVI Reset	74
7.5	SIM Counter	74
7.5.1	SIM Counter During Power-On Reset	74
7.5.2	SIM Counter During Stop Mode Recovery	74
7.5.3	SIM Counter and Reset States	75
7.6	Exception Control	75
7.6.1	Interrupts	75
7.6.1.1	Hardware Interrupts	77
7.6.1.2	SWI Instruction	79
7.6.2	Interrupt Status Registers	79
7.6.2.1	Interrupt Status Register 1	80
7.6.2.2	Interrupt Status Register 2	80
7.6.2.3	Interrupt Status Register 3	81
7.6.3	Reset	81
7.6.4	Break Interrupts	81
7.6.5	Status Flag Protection in Break Mode	81
7.7	Low-Power Modes	82
7.7.1	Wait Mode	82
7.7.2	Stop Mode	84
7.8	SIM Registers	85
7.8.1	Break Status Register (BSR)	85
7.8.2	Reset Status Register (RSR)	86
7.8.3	Break Flag Control Register (BFCR)	88

Section 8. Oscillator (OSC)

8.1	Contents	89
8.2	Introduction	89

8.3	X-tal Oscillator (MC68HC08xxx)	90
8.4	RC Oscillator (MC68HRC08xxx)	91
8.5	I/O Signals	92
8.5.1	Crystal Amplifier Input Pin (OSC1)	92
8.5.2	Crystal Amplifier Output Pin (OSC2/PTA6/RCCLK)	92
8.5.3	Oscillator Enable Signal (SIMOSCEN)	92
8.5.4	X-tal Oscillator Clock (XTALCLK)	92
8.5.5	RC Oscillator Clock (RCCLK)	93
8.5.6	Oscillator Out 2 (2OSCOUT)	93
8.5.7	Oscillator Out (OSCOUT)	93
8.6	Low Power Modes	93
8.6.1	Wait Mode	93
8.6.2	Stop Mode	93
8.7	Oscillator During Break Mode	94

Section 9. Monitor ROM (MON)

9.1	Contents	95
9.2	Introduction	95
9.3	Features	96
9.4	Functional Description	96
9.4.1	Entering Monitor Mode	98
9.4.2	Baud Rate	100
9.4.3	Data Format	100
9.4.4	Echoing	100
9.4.5	Break Signal	101
9.4.6	Commands	101

Section 10. Timer Interface Module (TIM)

10.1	Contents	105
10.2	Introduction	106
10.3	Features	106
10.4	Pin Name Conventions	106

10.5	Functional Description	107
10.5.1	TIM Counter Prescaler	109
10.5.2	Input Capture	109
10.5.3	Output Compare	109
10.5.3.1	Unbuffered Output Compare	110
10.5.3.2	Buffered Output Compare	110
10.5.4	Pulse Width Modulation (PWM)	111
10.5.4.1	Unbuffered PWM Signal Generation	112
10.5.4.2	Buffered PWM Signal Generation	113
10.5.4.3	PWM Initialization	114
10.6	Interrupts	115
10.7	Wait Mode	115
10.8	TIM During Break Interrupts	116
10.9	I/O Signals	116
10.10	I/O Registers	117
10.10.1	TIM Status and Control Register (TSC)	117
10.10.2	TIM Counter Registers (TCNTH:TCNTL)	119
10.10.3	TIM Counter Modulo Registers (TMODH:TMODL)	120
10.10.4	TIM Channel Status and Control Registers (TSC0:TSC1)	121
10.10.5	TIM Channel Registers (TCH0H/L:TCH1H/L)	125

Section 11. Analog-to-Digital Converter (ADC)

11.1	Contents	127
11.2	Introduction	127
11.3	Features	128
11.4	Functional Description	128
11.4.1	ADC Port I/O Pins	129
11.4.2	Voltage Conversion	130
11.4.3	Conversion Time	130
11.4.4	Continuous Conversion	130
11.4.5	Accuracy and Precision	131
11.5	Interrupts	131

11.6	Low-Power Modes	131
11.6.1	Wait Mode	131
11.6.2	Stop Mode	131
11.7	I/O Signals	131
11.7.1	ADC Voltage In (ADCVIN)	132
11.8	I/O Registers	132
11.8.1	ADC Status and Control Register	132
11.8.2	ADC Data Register	134
11.8.3	ADC Input Clock Register	135

Section 12. I/O Ports

12.1	Contents	137
12.2	Introduction	137
12.3	Port A	138
12.3.1	Port A Data Register (PTA)	139
12.3.2	Data Direction Register A (DDRA)	140
12.3.3	Port A Input Pull-up Enable Register (PTAPUE)	141
12.4	Port B	143
12.4.1	Port B Data Register (PTB)	143
12.4.2	Data Direction Register B (DDRB)	143
12.5	Port D	145
12.5.1	Port D Data Register (PTD)	145
12.5.2	Data Direction Register D (DDRD)	146
12.5.3	Port D Control Register (PDCR)	147

Section 13. External Interrupt (IRQ)

13.1	Contents	149
13.2	Introduction	149
13.3	Features	149
13.4	Functional Description	150
13.4.1	$\overline{\text{IRQ1}}$ Pin	151
13.5	IRQ Module During Break Interrupts	153
13.6	IRQ Status and Control Register (ISCR)	153

Section 14. Keyboard Interrupt Module (KBI)

14.1	Contents	155
14.2	Introduction	155
14.3	Features	155
14.4	Functional Description	156
14.4.1	Keyboard Initialization	158
14.4.2	Keyboard Status and Control Register	159
14.4.3	Keyboard Interrupt Enable Register	160
14.5	Wait Mode	161
14.6	Stop Mode	161
14.7	Keyboard Module During Break Interrupts	161

Section 15. Computer Operating Properly (COP)

15.1	Contents	163
15.2	Introduction	163
15.3	Functional Description	164
15.4	I/O Signals	165
15.4.1	2OSCOUT	165
15.4.2	COPCTL Write	165
15.4.3	Power-On Reset	165
15.4.4	Internal Reset	165
15.4.5	Reset Vector Fetch	166
15.4.6	COPD (COP Disable)	166
15.4.7	COPRS (COP Rate Select)	166
15.5	COP Control Register	167
15.6	Interrupts	167
15.7	Monitor Mode	167
15.8	Low-Power Modes	167
15.8.1	Wait Mode	167
15.8.2	Stop Mode	168
15.9	COP Module During Break Mode	168

Section 16. Low Voltage Inhibit (LVI)

16.1	Contents	169
16.2	Introduction	169
16.3	Features	169
16.4	Functional Description	170
16.5	LVI Control Register (CONFIG2/CONFIG1)	170
16.6	Low-Power Modes	171
16.6.1	Wait Mode	171
16.6.2	Stop Mode	171

Section 17. Break Module (BREAK)

17.1	Contents	173
17.2	Introduction	173
17.3	Features	174
17.4	Functional Description	174
17.4.1	Flag Protection During Break Interrupts	176
17.4.2	CPU During Break Interrupts	176
17.4.3	TIM During Break Interrupts	176
17.4.4	COP During Break Interrupts	176
17.5	Break Module Registers	176
17.5.1	Break Status and Control Register (BRKSCR)	177
17.5.2	Break Address Registers	178
17.5.3	Break Status Register	178
17.5.4	Break Flag Control Register (BFCR)	180
17.6	Low-Power Modes	180
17.6.1	Wait Mode	180
17.6.2	Stop Mode	180

Section 18. Electrical Specifications

18.1	Contents	181
18.2	Introduction	181

18.3	Absolute Maximum Ratings	182
18.4	Functional Operating Range	183
18.5	Thermal Characteristics	183
18.6	5V DC Electrical Characteristics	184
18.7	5V Control Timing	185
18.8	5V Oscillator Characteristics	186
18.9	3V DC Electrical Characteristics	187
18.10	3V Control Timing	188
18.11	3V Oscillator Characteristics	189
18.12	Typical Supply Currents	190
18.13	ADC Characteristics	191

Section 19. Mechanical Specifications

19.1	Contents	193
19.2	Introduction	193
19.3	20-Pin PDIP	194
19.4	20-Pin SOIC	194
19.5	28-Pin PDIP	195
19.6	28-Pin SOIC	195



EEPW 电子产品世界
.com.cn

List of Figures

Figure	Title	Page
1-1	MCU Block Diagram	24
1-2	MCU Pin Assignments	25
2-1	Memory Map	28
2-2	Control, Status, and Data Registers	30
5-1	Configuration Register 2 (CONFIG2)	42
5-2	Configuration Register 1 (CONFIG1)	43
6-1	CPU Registers	47
6-2	Accumulator (A)	47
6-3	Index Register (H:X)	48
6-4	Stack Pointer (SP)	49
6-5	Program Counter (PC)	49
6-6	Condition Code Register (CCR)	50
7-1	SIM Block Diagram	67
7-2	SIM I/O Register Summary	68
7-3	SIM Clock Signals	69
7-4	External Reset Timing	71
7-5	Internal Reset Timing	71
7-6	Sources of Internal Reset	71
7-7	POR Recovery	72
7-8	Interrupt Processing	76
7-9	Interrupt Entry	77
7-10	Interrupt Recovery	77
7-11	Interrupt Recognition Example	78
7-12	Interrupt Status Register 1 (INT1)	80
7-13	Interrupt Status Register 2 (INT2)	80
7-14	Interrupt Status Register 3 (INT3)	81

Figure	Title	Page
7-15	Wait Mode Entry Timing	83
7-16	Wait Recovery from Interrupt or Break	83
7-17	Wait Recovery from Internal Reset.	83
7-18	Stop Mode Entry Timing	84
7-19	Stop Mode Recovery from Interrupt or Break.	85
7-20	Break Status Register (BSR)	85
7-21	Reset Status Register (RSR)	87
7-22	Break Flag Control Register (BFCR)	88
8-1	X-tal Oscillator External Connections	90
8-2	RC Oscillator External Connections	91
9-1	Monitor Mode Circuit.	97
9-2	Monitor Data Format.	100
9-3	Sample Monitor Waveforms	100
9-4	Read Transaction	101
9-5	Break Transaction.	101
10-1	TIM Block Diagram	107
10-2	TIM I/O Register Summary	108
10-3	PWM Period and Pulse Width	112
10-4	TIM Status and Control Register (TSC)	117
10-5	TIM Counter Registers (TCNTH:TCNTL)	120
10-6	TIM Counter Modulo Registers (TMODH:TMODL).	121
10-7	TIM Channel Status and Control Registers (TSC0:TSC1)	122
10-8	CHxMAX Latency	125
10-9	TIM Channel Registers (TCH0H/L:TCH1H/L).	126
11-1	ADC I/O Register Summary	128
11-2	ADC Block Diagram	129
11-3	ADC Status and Control Register (ADSCR).	132
11-4	ADC Data Register (ADR)	135
11-5	ADC Input Clock Register (ADICLK)	135
12-1	I/O Port Register Summary.	138
12-2	Port A Data Register (PTA)	139
12-3	Data Direction Register A (DDRA)	140

Figure	Title	Page
12-4	Port A I/O Circuit.	141
12-5	Port A Input Pull-up Enable Register (PTAPUE)	142
12-6	Port B Data Register (PTB)	143
12-7	Data Direction Register B (DDRB)	143
12-8	Port B I/O Circuit.	144
12-9	Port D Data Register (PTD)	145
12-10	Data Direction Register D (DDRD)	146
12-11	Port D I/O Circuit.	146
12-12	Port D Control Register (PDCR)	147
13-1	IRQ Module Block Diagram	151
13-2	IRQ I/O Register Summary	151
13-3	IRQ Status and Control Register (INTSCR)	153
13-4	Configuration Register 2 (CONFIG2)	154
14-1	KBI I/O Register Summary	156
14-2	Keyboard Interrupt Block Diagram	156
14-3	Keyboard Status and Control Register (KBSCR)	159
14-4	Keyboard Interrupt Enable Register (KBIER)	160
15-1	COP Block Diagram	164
15-2	Configuration Register 1 (CONFIG1)	166
15-3	COP Control Register (COPCTL)	167
16-1	LVI Module Block Diagram	170
16-2	Configuration Register 2 (CONFIG2)	170
16-3	Configuration Register 1 (CONFIG1)	171
17-1	Break Module Block Diagram	175
17-2	Break I/O Register Summary	175
17-3	Break Status and Control Register (BRKSCR)	177
17-4	Break Address Register High (BRKH)	178
17-5	Break Address Register Low (BRKL)	178
17-6	Break Status Register (BSR)	178
17-7	Break Flag Control Register (BFCR)	180

Figure	Title	Page
---------------	--------------	-------------

18-1	RC vs. Frequency (5V @25°C)	186
18-2	RC vs. Frequency (3V @25°C)	189
18-3	Typical Operating I_{DD} , with all Modules Turned On (25 °C) ..	190
18-4	Typical Wait Mode I_{DD} , with ADC Turned On (25 °C)	190
18-5	Typical Stop Mode I_{DD} , with all Modules Disabled (25 °C) ..	190
19-1	20-Pin PDIP (Case #738)	194
19-2	20-Pin SOIC (Case #751D)	194
19-3	28-Pin PDIP (Case #710)	195
19-4	28-Pin SOIC (Case #751F)	195



List of Tables

Table	Title	Page
1-1	Summary of Device Variations	21
1-2	Pin Functions	26
2-1	Vector Addresses	35
6-1	Instruction Set Summary	54
6-2	Opcode Map	63
7-1	Signal Name Conventions	67
7-2	PIN Bit Set Timing	70
7-3	Interrupt Sources	79
7-4	SIM Registers	85
9-1	Monitor Mode Entry Requirements and Options	98
9-2	Monitor Mode Vector Differences	99
9-3	Monitor Baud Rate Selection	100
9-4	READ (Read Memory) Command	102
9-5	WRITE (Write Memory) Command	102
9-6	IREAD (Indexed Read) Command	103
9-7	IWRITE (Indexed Write) Command	103
9-8	READSP (Read Stack Pointer) Command	104
9-9	RUN (Run User Program) Command	104
10-1	Pin Name Conventions	106
10-2	Prescaler Selection	119
10-3	Mode, Edge, and Level Selection	124
11-1	MUX Channel Select	134
11-2	ADC Clock Divide Ratio	136

Table	Title	Page
12-1	Port A Pin Functions	142
12-2	Port B Pin Functions	144
12-3	Port D Pin Functions	147
18-1	Absolute Maximum Ratings	182
18-2	Operating Range	183
18-3	Thermal Characteristics	183
18-4	DC Electrical Characteristics (5V)	184
18-5	Control Timing (5V)	185
18-6	Oscillator Component Specifications (5V)	186
18-7	DC Electrical Characteristics (3V)	187
18-8	Control Timing (3V)	188
18-9	Oscillator Component Specifications (3V)	189
18-10	ADC Characteristics	191

EEPW.com.cn

Section 1. General Description

1.1 Contents

1.2	Introduction	21
1.3	Features	22
1.4	MCU Block Diagram	23
1.5	Pin Assignments	25
1.6	Pin Functions	26

1.2 Introduction

The MC68H(R)C08JL3 is a member of the low-cost, high-performance M68HC08 Family of 8-bit microcontroller units (MCUs). The M68HC08 Family is based on the customer-specified integrated circuit (CSIC) design strategy. All MCUs in the family use the enhanced M68HC08 central processor unit (CPU08) and are available with a variety of modules, memory sizes and types, and package types.

Table 1-1. Summary of Device Variations

Device	ROM Size	Pin Count
MC68H(R)C08JL3	4096 bytes	28 pins
MC68H(R)C08JK3	4096 bytes	20 pins
MC68H(R)C08JK1	1536 bytes	20 pins

All references to the MC68H(R)C08JL3 in this data book apply equally to the MC68H(R)C08JK3 and MC68H(R)C08JK1, unless otherwise stated.

1.3 Features

Features of the MC68H(R)C08JL3 include the following:

- High-performance M68HC08 architecture
- Fully upward-compatible object code with M6805, M146805, and M68HC05 Families
- Low-power design; fully static with stop and wait modes
- 5V and 3V operating voltages
- 8MHz internal bus operation
- RC-oscillator circuit or crystal-oscillator options
- ROM security¹
- User read-only memory (ROM)
 - 4096 bytes for MC68H(R)C08JL3/JK3
 - 1536 bytes for MC68H(R)C08JK1
- 128 bytes of on-chip random-access memory (RAM)
- 2-channel, 16-bit timer interface module (TIM)
- 12-channel, 8-bit analog-to-digital converter (ADC)
- 23 general purpose I/O ports for MC68H(R)C08JL3:
 - 7 keyboard interrupt with internal pull-up
 - 10 LED drivers
 - 2 × 25mA open-drain I/O with pull-up
 - 2 ICAP/OCAP/PWM
- 15 general purpose I/O ports for MC68H(R)C08JK3/JK1:
 - 1 keyboard interrupt with internal pull-up (with RC oscillator option selected)
 - 4 LED drivers
 - 2 × 25mA open-drain I/O with pull-up
 - 2 ICAP/OCAP/PWM

1. No security feature is absolutely secure. However, Freescale's strategy is to make reading or copying the ROM difficult for unauthorized users.

- System protection features:
 - Optional computer operating properly (COP) reset
 - Optional low-voltage detection with reset and selectable trip points for 3V and 5V operation.
 - Illegal opcode detection with reset
 - Illegal address detection with reset
- Master reset pin with internal pull-up and power-on reset
- $\overline{\text{IRQ1}}$ with programmable pull-up and schmitt-trigger input
- 28-pin PDIP and 28-pin SOIC packages for MC68H(R)C08JL3
- 20-pin PDIP and 20-pin SOIC packages for MC68H(R)C08JK3/JK1

Features of the CPU08 include the following:

- Enhanced HC05 programming model
- Extensive loop control functions
- 16 addressing modes (eight more than the HC05)
- 16-bit index register and stack pointer
- Memory-to-memory data transfers
- Fast 8×8 multiply instruction
- Fast 16/8 divide instruction
- Binary-coded decimal (BCD) instructions
- Optimization for controller applications
- Efficient C language support

1.4 MCU Block Diagram

Figure 1-1 shows the structure of the MC68H(R)C08JL3.

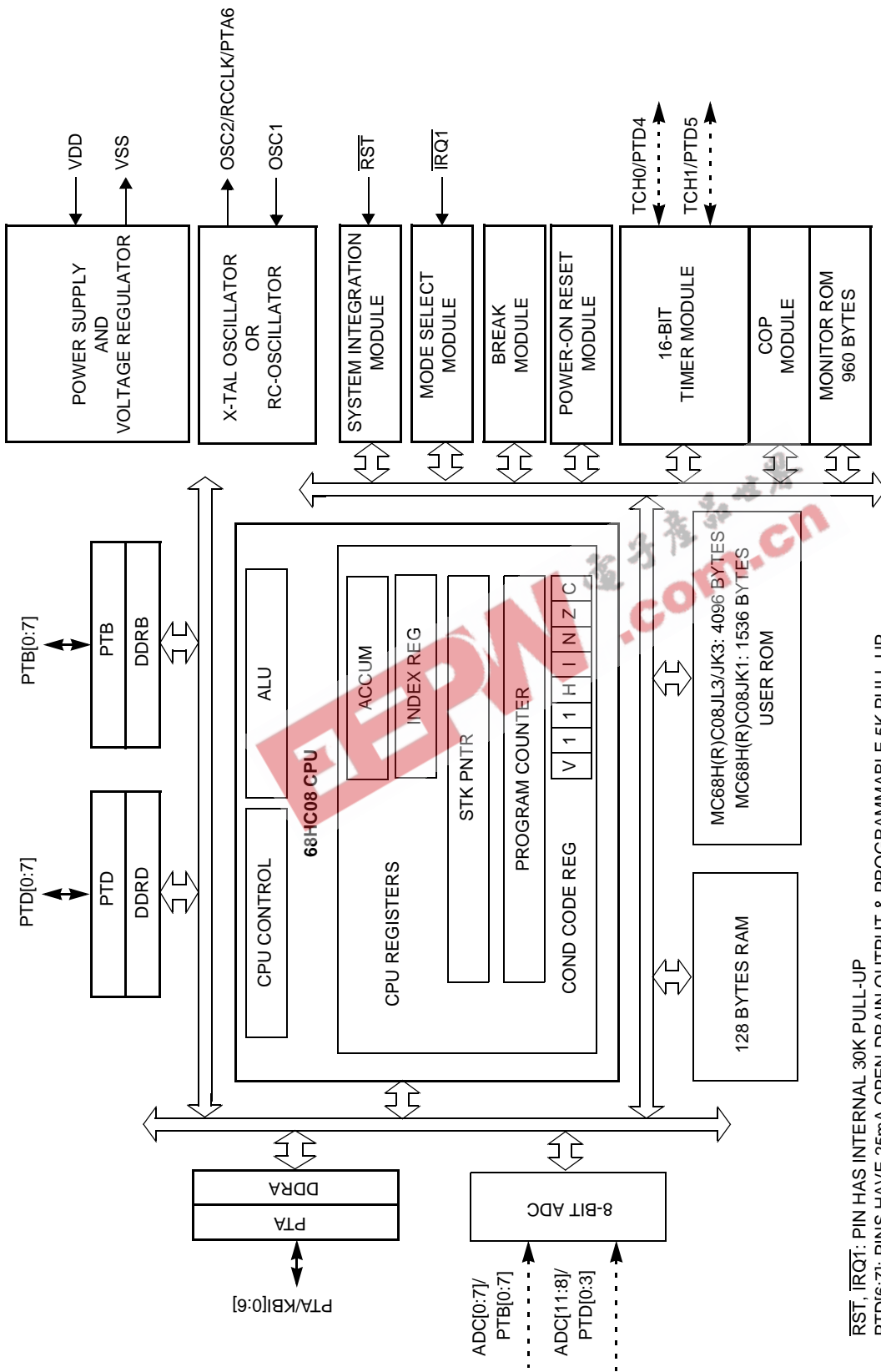

RST, IRQ1: PIN HAS INTERNAL 30K PULL-UP
 PTD[6:7]: PINS HAVE 25mA OPEN-DRAIN OUTPUT & PROGRAMMABLE 5K PULL-UP
 PTA[0:5], PTD[2:3], PTB[6:7]: PIN HAS LED DRIVE
 PTA[0:6]: PINS HAVE PROGRAMMABLE KEYBOARD INTERRUPT AND PULL-UP
 PTA[0:5] and PTD[0:1]: NOT AVAILABLE ON 20-PIN DEVICES – MC68H(R)C08JK3/JK1

Figure 1-1. MCU Block Diagram

1.5 Pin Assignments

The MC68H(R)C08JL3 is available in 28-pin packages and the MC68H(R)C08JK3/JK1 in 20-pin packages. **Figure 1-2** shows the pin assignment for the two packages.

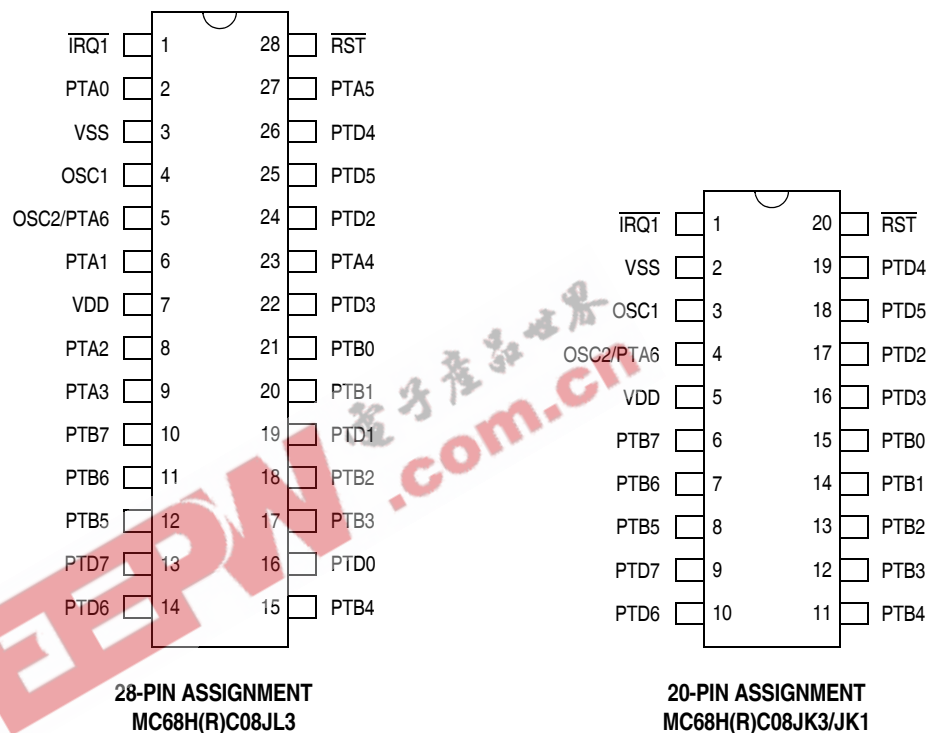

Pins not bonded out on 20-pin package:

PTA0, PTA1, PTA2, PTA3, PTA4, PTA5,
PTD0, PTD1.

Figure 1-2. MCU Pin Assignments

1.6 Pin Functions

Description of the pin functions are provided in [Table 1-2](#).

Table 1-2. Pin Functions

PIN NAME	PIN DESCRIPTION	IN/OUT	VOLTAGE LEVEL
VDD	Power supply.	In	5V or 3V
VSS	Power supply ground	Out	0V
$\overline{\text{RST}}$	RESET input, active low. With Internal pull-up and schmitt trigger input.	Input	VDD
$\overline{\text{IRQ1}}$	External IRQ pin. With software programmable internal pull-up and schmitt trigger input. This pin is also used for mode entry selection.	Input	VDD to VDD+V _{HI}
OSC1	X-tal or RC oscillator input.	In	Analog
OSC2	For X-tal oscillator option: X-tal oscillator output, this is the inverting OSC1 signal.	Out	Analog
	For RC oscillator option: Default is RCCLK output. Shared with PTA6/KBI6, with programmable pull-up.	In/Out	VDD
PTA[0:6]	7-bit general purpose I/O port.	In/Out	VDD
	Shared with 7 keyboard interrupts KBI[0:6].	In	VDD
	Each pin has programmable internal pull-up device.	In	VDD
PTB[0:7]	8-bit general purpose I/O port.	In/Out	VDD
	Shared with 8 ADC inputs, ADC[0:7].	In	Analog
PTD[0:7]	8-bit general purpose I/O port.	In/Out	VDD
	PTD[3:0] shared with 4 ADC inputs, ADC[8:11].	Input	Analog
	PTD[4:5] shared with TIM channels, TCH0 and TCH1.	In/Out	VDD
	PTD[6:7] can be configured as 25mA open-drain output with pull-up.	In/Out	VDD

NOTE: On the 20-pin package, the following pins are not available:
PTA0, PTA1, PTA2, PTA3, PTA4, PTA5, PTD0, and PTD1.

Section 2. Memory

2.1 Contents

2.2	Introduction	27
2.3	I/O Section	29
2.4	Monitor ROM	29

2.2 Introduction

The CPU08 can address 64 Kbytes of memory space. The memory map, shown in [Figure 2-1](#), includes:

- 4096 bytes of user ROM for MC68H(R)C08JL3/JK3
1536 bytes of user ROM for MC68H(R)C08JK1
- 128 bytes of RAM
- 48 bytes of user-defined vectors
- 960 bytes of Monitor ROM

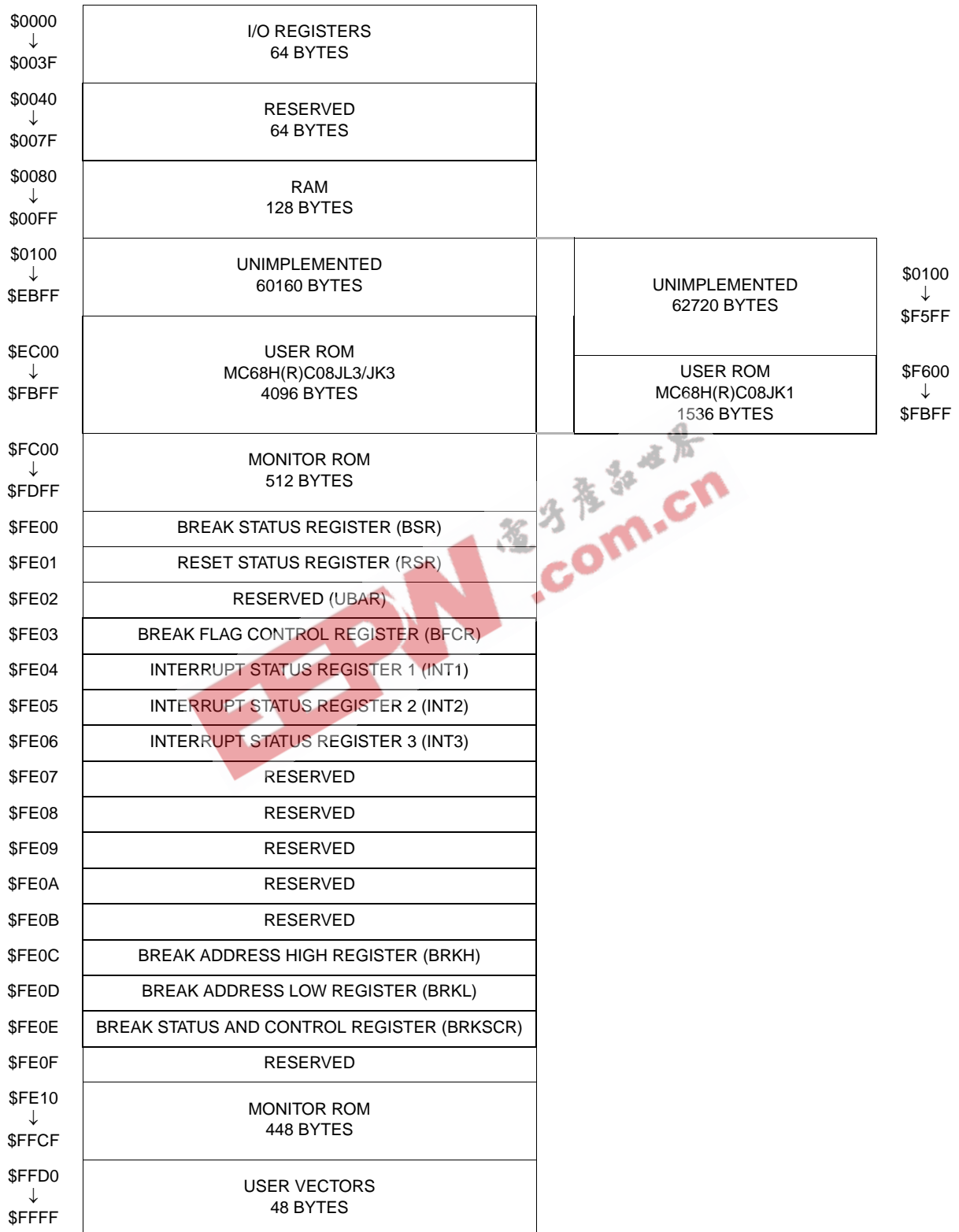

Figure 2-1. Memory Map

2.3 I/O Section

Addresses \$0000–\$003F, shown in [Figure 2-2](#), contain most of the control, status, and data registers. Additional I/O registers have the following addresses:

- \$FE00 (Break Status Register, BSR)
- \$FE01 (Reset Status Register, RSR)
- \$FE02 (Reserved, SUBAR)
- \$FE03 (Break Flag Control Register, BFCR)
- \$FE04 (Interrupt Status Register 1, INT1)
- \$FE05 (Interrupt Status Register 2, INT2)
- \$FE06 (Interrupt Status Register 3, INT3)
- \$FE07 (Reserved)
- \$FE08 (Reserved)
- \$FE09 (Reserved)
- \$FE0A (Reserved)
- \$FE0B (Reserved)
- \$FE0C (Break Address Register High, BRKH)
- \$FE0D (Break Address Register Low, BRKL)
- \$FE0E (Break Status and Control Register, BRKSCR)
- \$FE0F (Reserved)
- \$FFFF (COP Control Register, COPCTL)

2.4 Monitor ROM

The 960 bytes at addresses \$FC00–\$FDFF and \$FE10–\$FFCF are reserved ROM addresses that contain the instructions for the monitor functions. (See [Section 9. Monitor ROM \(MON\)](#).)

Addr.	Register Name	Bit 7	6	5	4	3	2	1	Bit 0	
\$0000	Port A Data Register (PTA)	Read:	0	PTA6	PTA5	PTA4	PTA3	PTA2	PTA1	PTA0
		Write:								
		Reset:	Unaffected by reset							
\$0001	Port B Data Register (PTB)	Read:	PTB7	PTB6	PTB5	PTB4	PTB3	PTB2	PTB1	PTB0
		Write:								
		Reset:	Unaffected by reset							
\$0002	Unimplemented	Read:								
		Write:								
\$0003	Port D Data Register (PTD)	Read:	PTD7	PTD6	PTD5	PTD4	PTD3	PTD2	PTD1	PTD0
		Write:								
		Reset:	Unaffected by reset							
\$0004	Data Direction Register A (DDRA)	Read:	0	DDRA6	DDRA5	DDRA4	DDRA3	DDRA2	DDRA1	DDRA0
		Write:								
		Reset:	0	0	0	0	0	0	0	0
\$0005	Data Direction Register B (DDRB)	Read:	DDRB7	DDRB6	DDRB5	DDRB4	DDRB3	DDRB2	DDRB1	DDRB0
		Write:								
		Reset:	0	0	0	0	0	0	0	0
\$0006	Unimplemented	Read:								
		Write:								
\$0007	Data Direction Register D (DDRD)	Read:	DDRD7	DDRD6	DDRD5	DDRD4	DDRD3	DDRD2	DDRD1	DDRD0
		Write:								
		Reset:	0	0	0	0	0	0	0	0
\$0008 ↓ \$0009	Unimplemented	Read:								
		Write:								
\$000A	Port D Control Register (PDCR)	Read:	0	0	0	0	SLOWD7	SLOWD6	PTDPU7	PTDPU6
		Write:								
		Reset:	0	0	0	0	0	0	0	0

= Unimplemented
 = Reserved

Figure 2-2. Control, Status, and Data Registers (Sheet 1 of 5)

Addr.	Register Name	Bit 7	6	5	4	3	2	1	Bit 0
\$000B ↓ \$000C	Unimplemented	Read: []	Write: []	[]	[]	[]	[]	[]	[]
\$000D	Port A Input Pull-up Enable Register (PTAPUE)	Read: PTA6EN	PTAPUE6	PTAPUE5	PTAPUE4	PTAPUE3	PTAPUE2	PTAPUE1	PTAPUE0
\$000E ↓ \$0019	Unimplemented	Read: []	Write: []	[]	[]	[]	[]	[]	[]
\$001A	Keyboard Status and Control Register (KBSCR)	Read: 0	0	0	0	KEYF	0	IMASKK	MODEK
		Write: []	[]	[]	[]	[]	ACKK	[]	[]
		Reset: 0	0	0	0	0	0	0	0
\$001B	Keyboard Interrupt Enable Register (KBIER)	Read: 0	KBIE6	KBIE5	KBIE4	KBIE3	KBIE2	KBIE1	KBIE0
		Write: []	[]	[]	[]	[]	[]	[]	[]
		Reset: 0	0	0	0	0	0	0	0
\$001C	Unimplemented	Read: []	Write: []	[]	[]	[]	[]	[]	[]
\$001D	IRQ Status and Control Register (INTSCR)	Read: 0	0	0	0	IRQF1	0	IMASK1	MODE1
		Write: []	[]	[]	[]	[]	ACK1	[]	[]
		Reset: 0	0	0	0	0	0	0	0
\$001E	Configuration Register 2 (CONFIG2) [†]	Read: IRQPUD	R	R	LVIT1	LVIT0	R	R	R
		Write: []	[]	[]	[]	[]	[]	[]	[]
		Reset: 0	0	0	0*	0*	0	0	0
\$001F	Configuration Register 1 (CONFIG1) [†]	Read: COPRS	R	R	LVID	R	SSREC	STOP	COPD
		Write: []	[]	[]	[]	[]	[]	[]	[]
		Reset: 0	0	0	0	0	0	0	0
\$0020	TIM Status and Control Register (TSC)	Read: TOF	TOIE	TSTOP	0	0	PS2	PS1	PS0
		Write: 0	[]	[]	TRST	[]	[]	[]	[]
		Reset: 0	0	1	0	0	0	0	0

= Unimplemented
 = Reserved

Figure 2-2. Control, Status, and Data Registers (Sheet 2 of 5)

Addr.	Register Name		Bit 7	6	5	4	3	2	1	Bit 0
\$0021	TIM Counter Register High (TCNTH)	Read:	Bit15	Bit14	Bit13	Bit12	Bit11	Bit10	Bit9	Bit8
		Write:								
		Reset:	0	0	0	0	0	0	0	0
\$0022	TIM Counter Register Low (TCNTL)	Read:	Bit7	Bit6	Bit5	Bit4	Bit3	Bit2	Bit1	Bit0
		Write:								
		Reset:	0	0	0	0	0	0	0	0
\$0023	TIM Counter Modulo Register High (TMODH)	Read:	Bit15	Bit14	Bit13	Bit12	Bit11	Bit10	Bit9	Bit8
		Write:								
		Reset:	1	1	1	1	1	1	1	1
\$0024	TIM Counter Modulo Register Low (TMDL)	Read:	Bit7	Bit6	Bit5	Bit4	Bit3	Bit2	Bit1	Bit0
		Write:								
		Reset:	1	1	1	1	1	1	1	1
\$0025	TIM Channel 0 Status and Control Register (TSC0)	Read:	CH0F	CH0IE	MS0B	MS0A	ELS0B	ELS0A	TOV0	CH0MAX
		Write:	0							
		Reset:	0	0	0	0	0	0	0	0
\$0026	TIM Channel 0 Register High (TCH0H)	Read:	Bit15	Bit14	Bit13	Bit12	Bit11	Bit10	Bit9	Bit8
		Write:								
		Reset:	Indeterminate after reset							
\$0027	TIM Channel 0 Register Low (TCH0L)	Read:	Bit7	Bit6	Bit5	Bit4	Bit3	Bit2	Bit1	Bit0
		Write:								
		Reset:	Indeterminate after reset							
\$0028	TIM Channel 1 Status and Control Register (TSC1)	Read:	CH1F	CH1IE	0	MS1A	ELS1B	ELS1A	TOV1	CH1MAX
		Write:	0							
		Reset:	0	0	0	0	0	0	0	0
\$0029	TIM Channel 1 Register High (TCH1H)	Read:	Bit15	Bit14	Bit13	Bit12	Bit11	Bit10	Bit9	Bit8
		Write:								
		Reset:	Indeterminate after reset							
\$002A	TIM Channel 1 Register Low (TCH1L)	Read:	Bit7	Bit6	Bit5	Bit4	Bit3	Bit2	Bit1	Bit0
		Write:								
		Reset:	Indeterminate after reset							

= Unimplemented
R = Reserved

Figure 2-2. Control, Status, and Data Registers (Sheet 3 of 5)

Addr.	Register Name	Bit 7	6	5	4	3	2	1	Bit 0
\$002B ↓ \$003B	Unimplemented	Read: []	[]	[]	[]	[]	[]	[]	[]
\$003C	ADC Status and Control Register (ADSCR)	Read: COCO	AIEN	ADCO	CH4	CH3	CH2	CH1	CH0
		Write: []	[]	[]	[]	[]	[]	[]	[]
		Reset: 0	0	0	1	1	1	1	1
\$003D	ADC Data Register (ADR)	Read: AD7	AD6	AD5	AD4	AD3	AD2	AD1	AD0
		Write: []	[]	[]	[]	[]	[]	[]	[]
		Reset: Indeterminate after reset							
\$003E	ADC Input Clock Register (ADICLK)	Read: ADIV2	ADIV1	ADIV0	0	0	0	0	0
		Write: []	[]	[]	[]	[]	[]	[]	[]
		Reset: 0	0	0	0	0	0	0	0
\$003F	Unimplemented	Read: []	[]	[]	[]	[]	[]	[]	[]
		Write: []	[]	[]	[]	[]	[]	[]	[]
\$FE00	Break Status Register (BSR)	Read: R	R	R	R	R	R	SBSW	R
		Write: []	[]	[]	[]	[]	[]	See note	[]
		Reset: 0							
Note: Writing a logic 0 clears SBSW.									
\$FE01	Reset Status Register (RSR)	Read: POR	PIN	COP	ILOP	ILAD	MODRST	LVI	0
		Write: []	[]	[]	[]	[]	[]	[]	[]
		POR: 1	0	0	0	0	0	0	0
\$FE02	Reserved	Read: R	R	R	R	R	R	R	R
		Write: []	[]	[]	[]	[]	[]	[]	[]
\$FE03	Break Flag Control Register (BFCR)	Read: BCFE	R	R	R	R	R	R	R
		Write: []	[]	[]	[]	[]	[]	[]	[]
		Reset: 0							
\$FE04	Interrupt Status Register 1 (INT1)	Read: 0	IF5	IF4	IF3	0	IF1	0	0
		Write: R	R	R	R	R	R	R	R
		Reset: 0	0	0	0	0	0	0	0
		[] = Unimplemented							[R] = Reserved

Figure 2-2. Control, Status, and Data Registers (Sheet 4 of 5)

Addr.	Register Name	Bit 7	6	5	4	3	2	1	Bit 0	
\$FE05	Interrupt Status Register 2 (INT2)	Read:	IF14	0	0	0	0	0	0	
		Write:	R	R	R	R	R	R	R	
		Reset:	0	0	0	0	0	0	0	0
\$FE06	Interrupt Status Register 3 (INT3)	Read:	0	0	0	0	0	0	IF15	
		Write:	R	R	R	R	R	R	R	
		Reset:	0	0	0	0	0	0	0	0
\$FE07 ↓ \$FE0B	Reserved	Read:	R	R	R	R	R	R	R	
		Write:								
\$FE0C	Break Address High Register (BRKH)	Read:	Bit15	Bit14	Bit13	Bit12	Bit11	Bit10	Bit9	Bit8
		Write:								
		Reset:	0	0	0	0	0	0	0	0
\$FE0D	Break Address low Register (BRKL)	Read:	Bit7	Bit6	Bit5	Bit4	Bit3	Bit2	Bit1	Bit0
		Write:								
		Reset:	0	0	0	0	0	0	0	0
\$FE0E	Break Status and Control Register (BRKSCR)	Read:	BRKE	BRKA	0	0	0	0	0	0
		Write:								
		Reset:	0	0	0	0	0	0	0	0
\$FFFF	COP Control Register (COPCTL)	Read:	Low byte of reset vector							
		Write:	Writing clears COP counter (any value)							
		Reset:	Unaffected by reset							

= Unimplemented
 = Reserved

Figure 2-2. Control, Status, and Data Registers (Sheet 5 of 5)

Table 2-1. Vector Addresses

Vector Priority	Vector	Address	Vector
Lowest  Highest	IF15	\$FFDE	ADC Conversion Complete Vector (High)
		\$FFDF	ADC Conversion Complete Vector (Low)
	IF14	\$FFE0	Keyboard Vector (High)
		\$FFE1	Keyboard Vector (Low)
	IF13 to IF6	—	Not Used
	IF5	\$FFF2	TIM Overflow Vector (High)
		\$FFF3	TIM Overflow Vector (Low)
	IF4	\$FFF4	TIM Channel 1 Vector (High)
		\$FFF5	TIM Channel 1 Vector (Low)
	IF3	\$FFF6	TIM Channel 0 Vector (High)
		\$FFF7	TIM Channel 0 Vector (Low)
	IF2	—	Not Used
	IF1	\$FFFA	$\overline{\text{IRQ}}$ Vector (High)
		\$FFFB	$\overline{\text{IRQ}}$ Vector (Low)
	—	\$FFFC	SWI Vector (High)
		\$FFFD	SWI Vector (Low)
—	\$FFFE	Reset Vector (High)	
	\$FFFF	Reset Vector (Low)	



EEPW 电子产品世界
.com.cn

Section 3. Random-Access Memory (RAM)

3.1 Contents

3.2	Introduction	37
3.3	Functional Description	37

3.2 Introduction

This section describes the 128 bytes of RAM.

3.3 Functional Description

Addresses \$0080 through \$00FF are RAM locations. The location of the stack RAM is programmable. The 16-bit stack pointer allows the stack to be anywhere in the 64-Kbyte memory space.

NOTE: *For correct operation, the stack pointer must point only to RAM locations.*

Within page zero are 128 bytes of RAM. Because the location of the stack RAM is programmable, all page zero RAM locations can be used for I/O control and user data or code. When the stack pointer is moved from its reset location at \$00FF, direct addressing mode instructions can access efficiently all page zero RAM locations. Page zero RAM, therefore, provides ideal locations for frequently accessed global variables.

Before processing an interrupt, the CPU uses five bytes of the stack to save the contents of the CPU registers.

NOTE: *For M6805 compatibility, the H register is not stacked.*

During a subroutine call, the CPU uses two bytes of the stack to store the return address. The stack pointer decrements during pushes and increments during pulls.

NOTE: *Be careful when using nested subroutines. The CPU may overwrite data in the RAM during a subroutine or during the interrupt stacking operation.*

EEPW 电子产品世界
.com.cn

Section 4. Read-Only Memory (ROM)

4.1 Contents

4.2	Introduction	39
4.3	Functional Description	39

4.2 Introduction

This section describes the 4096 or 1536 bytes of read-only memory (ROM) and 48 bytes of user vectors.

4.3 Functional Description

These addresses are user ROM locations:

\$EC00–\$FBFF; user memory, 4096 bytes on MC68H(R)C08JL3/JK3.

\$F600–\$FBFF; user memory, 1536 bytes on MC68H(R)C08JK1.

\$FFD0–\$FFFF (These locations are reserved for user-defined interrupt and reset vectors.)

NOTE: A security feature prevents viewing of the ROM contents.¹

1. No security feature is absolutely secure. However, Freescale's strategy is to make reading or copying the ROM contents difficult for unauthorized users.



EEPW 电子产品世界
.com.cn

Section 5. Configuration Register (CONFIG)

5.1 Contents

5.2	Introduction	41
5.3	Functional Description	42

5.2 Introduction

This section describes the configuration registers (CONFIG1 and CONFIG2). The configuration registers enables or disables the following options:

- Stop mode recovery time ($32 \times 2\text{OSCOU}$ cycles or $4096 \times 2\text{OSCOU}$ cycles)
- STOP instruction
- Computer operating properly module (COP)
- COP reset period (COPRS), $(2^{13}-2^4) \times 2\text{OSCOU}$ or $(2^{18}-2^4) \times 2\text{OSCOU}$
- Enable LVI circuit
- Select LVI trip voltage

5.3 Functional Description

The configuration register is used in the initialization of various options. The configuration register can be written once after each reset. All of the configuration register bits are cleared during reset. Since the various options affect the operation of the MCU it is recommended that this register be written immediately after reset. The configuration register is located at \$001E and \$001F, and may be read at anytime.

NOTE: The CONFIG registers are one-time writable by the user after each reset. Upon a reset, the CONFIG registers default to predetermined settings as shown in [Figure 5-1](#) and [Figure 5-2](#).

Address: \$001E

	Bit 7	6	5	4	3	2	1	Bit 0
Read:	IRQPUD	R	R	LVIT1	LVIT0	R	R	R
Write:								
Reset:	0	0	0	Not affected	Not affected	0	0	0
POR:	0	0	0	0	0	0	0	0

R = Reserved

Figure 5-1. Configuration Register 2 (CONFIG2)

IRQPUD — $\overline{\text{IRQ1}}$ Pin Pull-up control bit

1 = Internal Pull-up is disconnected

0 = Internal Pull-up is connected between $\overline{\text{IRQ1}}$ pin and V_{DD}

LVIT1, LVIT0 — Low Voltage Inhibit trip voltage selection bits

Detail description of the LVI control signals is given in [Section 16](#).

Address: \$001F

	Bit 7	6	5	4	3	2	1	Bit 0
Read:	COPRS	R	R	LVID	R	SSREC	STOP	COPD
Write:								
Reset:	0	0	0	0	0	0	0	0

R = Reserved

Figure 5-2. Configuration Register 1 (CONFIG1)

COPRS —pCOP reset period selection bit

1 = COP reset cycle = $(2^{13} - 2^4) \times 2\text{OSCOUT}$

0 = COP reset cycle = $(2^{18} - 2^4) \times 2\text{OSCOUT}$

LVID —pLow Voltage Inhibit Disable Bit

1 = Low Voltage Inhibit disabled

0 = Low Voltage Inhibit enabled

SSREC — Short Stop Recovery Bit

SSREC enables the CPU to exit stop mode with a delay of

$32 \times \text{OSCXCLK}$ cycles instead of a $4096 \times 2\text{OSCOUT}$ cycle delay.

1 = Stop mode recovery after $32 \times 2\text{OSCOUT}$ cycles

0 = Stop mode recovery after $4096 \times 2\text{OSCOUT}$ cycles

NOTE: *Exiting stop mode by pulling reset will result in the long stop recovery.*

If using an external crystal, do not set the SSREC bit.

STOP enables the STOP instruction.

1 = STOP instruction enabled

0 = STOP instruction treated as illegal opcode

COPD — COP Disable Bit

COPD disables the COP module. (See [Section 15. Computer Operating Properly \(COP\)](#).)

1 = COP module disabled

0 = COP module enabled



EEPW 电子产品世界
.com.cn

Section 6. Central Processor Unit (CPU)

6.1 Contents

6.2	Introduction	45
6.3	Features	46
6.4	CPU Registers	46
6.4.1	Accumulator	47
6.4.2	Index Register	48
6.4.3	Stack Pointer	48
6.4.4	Program Counter	49
6.4.5	Condition Code Register	49
6.5	Arithmetic/Logic Unit (ALU)	52
6.6	Low-Power Modes	52
6.6.1	Wait Mode	52
6.6.2	Stop Mode	53
6.7	CPU During Break Interrupts	53
6.8	Instruction Set Summary	53
6.9	Opcode Map	53

6.2 Introduction

The M68HC08 CPU (central processor unit) is an enhanced and fully object-code-compatible version of the M68HC05 CPU. The *CPU08 Reference Manual* (Freescale document order number CPU08RM/AD) contains a description of the CPU instruction set, addressing modes, and architecture.

6.3 Features

- Object code fully upward-compatible with M68HC05 Family
- 16-bit stack pointer with stack manipulation instructions
- 16-bit index register with x-register manipulation instructions
- 8-MHz CPU internal bus frequency
- 64-Kbyte program/data memory space
- 16 addressing modes
- Memory-to-memory data moves without using accumulator
- Fast 8-bit by 8-bit multiply and 16-bit by 8-bit divide instructions
- Enhanced binary-coded decimal (BCD) data handling
- Modular architecture with expandable internal bus definition for extension of addressing range beyond 64 Kbytes
- Low-power stop and wait modes

6.4 CPU Registers

Figure 6-1 shows the five CPU registers. CPU registers are not part of the memory map.

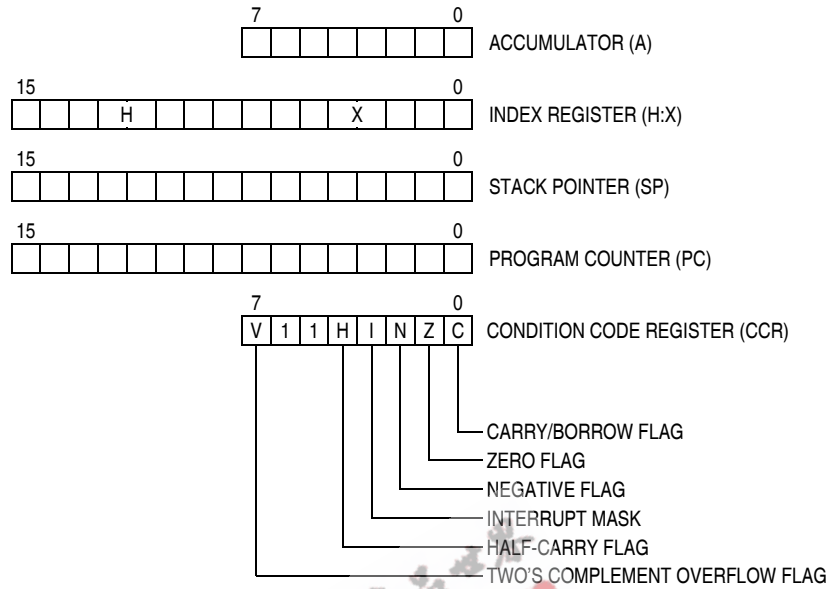

Figure 6-1. CPU Registers

6.4.1 Accumulator

The accumulator is a general-purpose 8-bit register. The CPU uses the accumulator to hold operands and the results of arithmetic/logic operations.

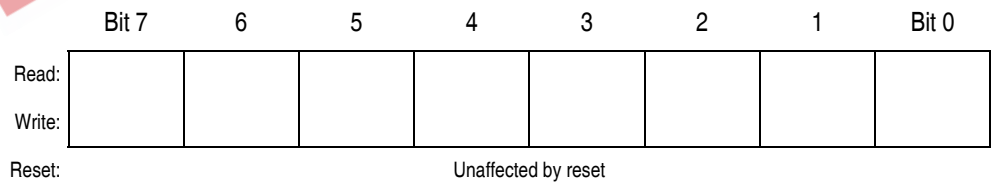

Figure 6-2. Accumulator (A)

6.4.2 Index Register

The 16-bit index register allows indexed addressing of a 64-Kbyte memory space. H is the upper byte of the index register, and X is the lower byte. H:X is the concatenated 16-bit index register.

In the indexed addressing modes, the CPU uses the contents of the index register to determine the conditional address of the operand.

The index register can serve also as a temporary data storage location.

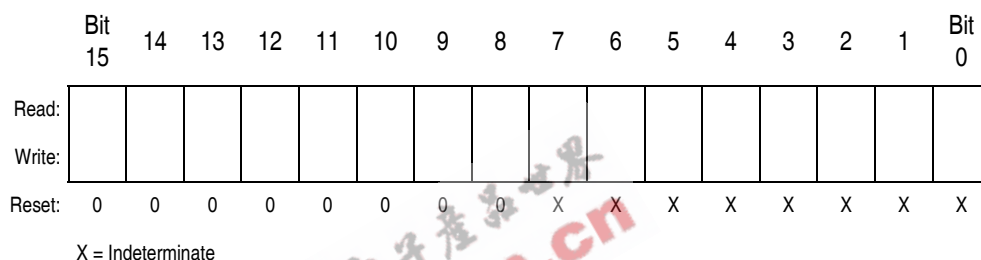

Figure 6-3. Index Register (H:X)

6.4.3 Stack Pointer

The stack pointer is a 16-bit register that contains the address of the next location on the stack. During a reset, the stack pointer is preset to \$00FF. The reset stack pointer (RSP) instruction sets the least significant byte to \$FF and does not affect the most significant byte. The stack pointer decrements as data is pushed onto the stack and increments as data is pulled from the stack.

In the stack pointer 8-bit offset and 16-bit offset addressing modes, the stack pointer can function as an index register to access data on the stack. The CPU uses the contents of the stack pointer to determine the conditional address of the operand.

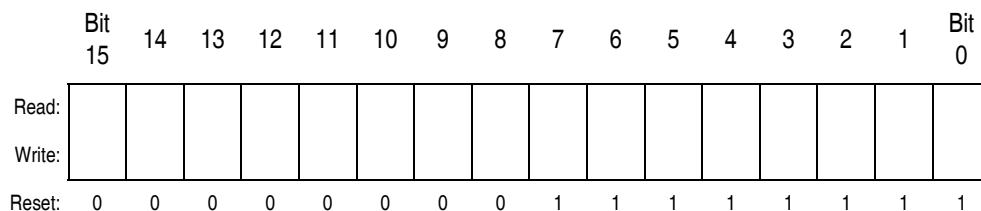

Figure 6-4. Stack Pointer (SP)

NOTE: *The location of the stack is arbitrary and may be relocated anywhere in RAM. Moving the SP out of page 0 (\$0000 to \$00FF) frees direct address (page 0) space. For correct operation, the stack pointer must point only to RAM locations.*

6.4.4 Program Counter

The program counter is a 16-bit register that contains the address of the next instruction or operand to be fetched.

Normally, the program counter automatically increments to the next sequential memory location every time an instruction or operand is fetched. Jump, branch, and interrupt operations load the program counter with an address other than that of the next sequential location.

During reset, the program counter is loaded with the reset vector address located at \$FFFE and \$FFFF. The vector address is the address of the first instruction to be executed after exiting the reset state.

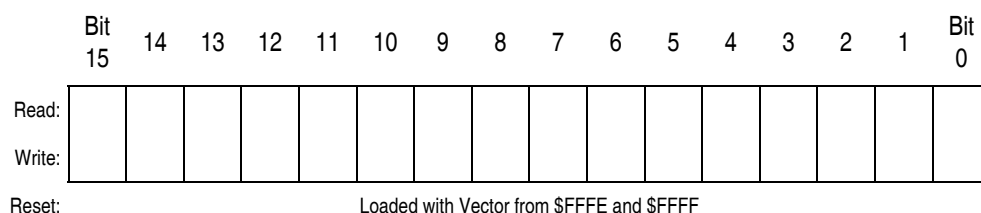

Figure 6-5. Program Counter (PC)

6.4.5 Condition Code Register

The 8-bit condition code register contains the interrupt mask and five flags that indicate the results of the instruction just executed. Bits 6 and

5 are set permanently to logic 1. The following paragraphs describe the functions of the condition code register.

	Bit 7	6	5	4	3	2	1	Bit 0
Read:	V	1	1	H	I	N	Z	C
Write:								
Reset:	X	1	1	X	1	X	X	X

X = Indeterminate

Figure 6-6. Condition Code Register (CCR)

V — Overflow Flag

The CPU sets the overflow flag when a two's complement overflow occurs. The signed branch instructions BGT, BGE, BLE, and BLT use the overflow flag.

- 1 = Overflow
- 0 = No overflow

H — Half-Carry Flag

The CPU sets the half-carry flag when a carry occurs between accumulator bits 3 and 4 during an add-without-carry (ADD) or add-with-carry (ADC) operation. The half-carry flag is required for binary-coded decimal (BCD) arithmetic operations. The DAA instruction uses the states of the H and C flags to determine the appropriate correction factor.

- 1 = Carry between bits 3 and 4
- 0 = No carry between bits 3 and 4

I — Interrupt Mask

When the interrupt mask is set, all maskable CPU interrupts are disabled. CPU interrupts are enabled when the interrupt mask is cleared. When a CPU interrupt occurs, the interrupt mask is set automatically after the CPU registers are saved on the stack, but before the interrupt vector is fetched.

1 = Interrupts disabled

0 = Interrupts enabled

NOTE: *To maintain M6805 Family compatibility, the upper byte of the index register (H) is not stacked automatically. If the interrupt service routine modifies H, then the user must stack and unstack H using the PSHH and PULH instructions.*

After the I bit is cleared, the highest-priority interrupt request is serviced first.

A return-from-interrupt (RTI) instruction pulls the CPU registers from the stack and restores the interrupt mask from the stack. After any reset, the interrupt mask is set and can be cleared only by the clear interrupt mask software instruction (CLI).

N — Negative flag

The CPU sets the negative flag when an arithmetic operation, logic operation, or data manipulation produces a negative result, setting bit 7 of the result.

1 = Negative result

0 = Non-negative result

Z — Zero flag

The CPU sets the zero flag when an arithmetic operation, logic operation, or data manipulation produces a result of \$00.

1 = Zero result

0 = Non-zero result

C — Carry/Borrow Flag

The CPU sets the carry/borrow flag when an addition operation produces a carry out of bit 7 of the accumulator or when a subtraction operation requires a borrow. Some instructions — such as bit test and branch, shift, and rotate — also clear or set the carry/borrow flag.

1 = Carry out of bit 7

0 = No carry out of bit 7

6.5 Arithmetic/Logic Unit (ALU)

The ALU performs the arithmetic and logic operations defined by the instruction set.

Refer to the *CPU08 Reference Manual* (Freescale document order number CPU08RM/AD) for a description of the instructions and addressing modes and more detail about the architecture of the CPU.

6.6 Low-Power Modes

The WAIT and STOP instructions put the MCU in low power-consumption standby modes.

6.6.1 Wait Mode

The WAIT instruction:

- Clears the interrupt mask (I bit) in the condition code register, enabling interrupts. After exit from wait mode by interrupt, the I bit remains clear. After exit by reset, the I bit is set.
- Disables the CPU clock

6.6.2 Stop Mode

The STOP instruction:

- Clears the interrupt mask (I bit) in the condition code register, enabling external interrupts. After exit from stop mode by external interrupt, the I bit remains clear. After exit by reset, the I bit is set.
- Disables the CPU clock

After exiting stop mode, the CPU clock begins running after the oscillator stabilization delay.

6.7 CPU During Break Interrupts

If a break module is present on the MCU, the CPU starts a break interrupt by:

- Loading the instruction register with the SWI instruction
- Loading the program counter with \$FFFC:\$FFFD or with \$FEFC:\$FEFD in monitor mode

The break interrupt begins after completion of the CPU instruction in progress. If the break address register match occurs on the last cycle of a CPU instruction, the break interrupt begins immediately.

A return-from-interrupt instruction (RTI) in the break routine ends the break interrupt and returns the MCU to normal operation if the break interrupt has been deasserted.

6.8 Instruction Set Summary

6.9 Opcode Map

See [Table 6-2](#).

Table 6-1. Instruction Set Summary

Source Form	Operation	Description	Effect on CCR						Address Mode	Opcode	Operand	Cycles
			V	H	I	N	Z	C				
ADC #opr ADC opr ADC opr ADC opr,X ADC opr,X ADC ,X ADC opr,SP ADC opr,SP	Add with Carry	$A \leftarrow (A) + (M) + (C)$	↑	↑	-	↑	↑	↑	IMM DIR EXT IX2 IX1 IX SP1 SP2	A9 B9 C9 D9 E9 F9 9EE9 9ED9	ii dd hh ll ee ff ff ff ff ee ff	2 3 4 4 3 2 4 5
ADD #opr ADD opr ADD opr ADD opr,X ADD opr,X ADD ,X ADD opr,SP ADD opr,SP	Add without Carry	$A \leftarrow (A) + (M)$	↑	↑	-	↑	↑	↑	IMM DIR EXT IX2 IX1 IX SP1 SP2	AB BB CB DB EB FB 9EEB 9EDB	ii dd hh ll ee ff ff ff ff ee ff	2 3 4 4 3 2 4 5
AIS #opr	Add Immediate Value (Signed) to SP	$SP \leftarrow (SP) + (16 \ll M)$	-	-	-	-	-	-	IMM	A7	ii	2
AIX #opr	Add Immediate Value (Signed) to H:X	$H:X \leftarrow (H:X) + (16 \ll M)$	-	-	-	-	-	-	IMM	AF	ii	2
AND #opr AND opr AND opr AND opr,X AND opr,X AND ,X AND opr,SP AND opr,SP	Logical AND	$A \leftarrow (A) \& (M)$	0	-	-	↑	↑	-	IMM DIR EXT IX2 IX1 IX SP1 SP2	A4 B4 C4 D4 E4 F4 9EE4 9ED4	ii dd hh ll ee ff ff ff ff ee ff	2 3 4 4 3 2 4 5
ASL opr ASLA ASLX ASL opr,X ASL ,X ASL opr,SP	Arithmetic Shift Left (Same as LSL)		↑	-	-	↑	↑	↑	DIR INH INH IX1 IX SP1	38 48 58 68 78 9E68	dd ff ff	4 1 1 4 3 5
ASR opr ASRA ASRX ASR opr,X ASR opr,X ASR opr,SP	Arithmetic Shift Right		↑	-	-	↑	↑	↑	DIR INH INH IX1 IX SP1	37 47 57 67 77 9E67	dd ff ff	4 1 1 4 3 5
BCC rel	Branch if Carry Bit Clear	$PC \leftarrow (PC) + 2 + rel \text{ ? } (C) = 0$	-	-	-	-	-	-	REL	24	rr	3
BCLR n, opr	Clear Bit n in M	$M_n \leftarrow 0$	-	-	-	-	-	-	DIR (b0) DIR (b1) DIR (b2) DIR (b3) DIR (b4) DIR (b5) DIR (b6) DIR (b7)	11 13 15 17 19 1B 1D 1F	dd dd dd dd dd dd dd dd	4 4 4 4 4 4 4 4

Table 6-1. Instruction Set Summary

Source Form	Operation	Description	Effect on CCR						Address Mode	Opcode	Operand	Cycles
			V	H	I	N	Z	C				
BCS <i>rel</i>	Branch if Carry Bit Set (Same as BLO)	$PC \leftarrow (PC) + 2 + rel ? (C) = 1$	-	-	-	-	-	-	REL	25	rr	3
BEQ <i>rel</i>	Branch if Equal	$PC \leftarrow (PC) + 2 + rel ? (Z) = 1$	-	-	-	-	-	-	REL	27	rr	3
BGE <i>opr</i>	Branch if Greater Than or Equal To (Signed Operands)	$PC \leftarrow (PC) + 2 + rel ? (N \oplus V) = 0$	-	-	-	-	-	-	REL	90	rr	3
BGT <i>opr</i>	Branch if Greater Than (Signed Operands)	$PC \leftarrow (PC) + 2 + rel ? (Z) (N \oplus V) = 0$	-	-	-	-	-	-	REL	92	rr	3
BHCC <i>rel</i>	Branch if Half Carry Bit Clear	$PC \leftarrow (PC) + 2 + rel ? (H) = 0$	-	-	-	-	-	-	REL	28	rr	3
BHCS <i>rel</i>	Branch if Half Carry Bit Set	$PC \leftarrow (PC) + 2 + rel ? (H) = 1$	-	-	-	-	-	-	REL	29	rr	3
BHI <i>rel</i>	Branch if Higher	$PC \leftarrow (PC) + 2 + rel ? (C) (Z) = 0$	-	-	-	-	-	-	REL	22	rr	3
BHS <i>rel</i>	Branch if Higher or Same (Same as BCC)	$PC \leftarrow (PC) + 2 + rel ? (C) = 0$	-	-	-	-	-	-	REL	24	rr	3
BIH <i>rel</i>	Branch if \overline{IRQ} Pin High	$PC \leftarrow (PC) + 2 + rel ? \overline{IRQ} = 1$	-	-	-	-	-	-	REL	2F	rr	3
BIL <i>rel</i>	Branch if \overline{IRQ} Pin Low	$PC \leftarrow (PC) + 2 + rel ? \overline{IRQ} = 0$	-	-	-	-	-	-	REL	2E	rr	3
BIT # <i>opr</i> BIT <i>opr</i> BIT <i>opr</i> BIT <i>opr</i> ,X BIT <i>opr</i> ,X BIT ,X BIT <i>opr</i> ,SP BIT <i>opr</i> ,SP	Bit Test	(A) & (M)	0	-	-	↑	↓	-	IMM DIR EXT IX2 IX1 IX SP1 SP2	A5 B5 C5 D5 E5 F5 9EE5 9ED5	ii dd hh ll ee ff ff ff ff ff	2 3 4 4 3 2 4 5
BLE <i>opr</i>	Branch if Less Than or Equal To (Signed Operands)	$PC \leftarrow (PC) + 2 + rel ? (Z) (N \oplus V) = 1$	-	-	-	-	-	-	REL	93	rr	3
BLO <i>rel</i>	Branch if Lower (Same as BCS)	$PC \leftarrow (PC) + 2 + rel ? (C) = 1$	-	-	-	-	-	-	REL	25	rr	3
BLS <i>rel</i>	Branch if Lower or Same	$PC \leftarrow (PC) + 2 + rel ? (C) (Z) = 1$	-	-	-	-	-	-	REL	23	rr	3
BLT <i>opr</i>	Branch if Less Than (Signed Operands)	$PC \leftarrow (PC) + 2 + rel ? (N \oplus V) = 1$	-	-	-	-	-	-	REL	91	rr	3
BMC <i>rel</i>	Branch if Interrupt Mask Clear	$PC \leftarrow (PC) + 2 + rel ? (I) = 0$	-	-	-	-	-	-	REL	2C	rr	3
BMI <i>rel</i>	Branch if Minus	$PC \leftarrow (PC) + 2 + rel ? (N) = 1$	-	-	-	-	-	-	REL	2B	rr	3
BMS <i>rel</i>	Branch if Interrupt Mask Set	$PC \leftarrow (PC) + 2 + rel ? (I) = 1$	-	-	-	-	-	-	REL	2D	rr	3
BNE <i>rel</i>	Branch if Not Equal	$PC \leftarrow (PC) + 2 + rel ? (Z) = 0$	-	-	-	-	-	-	REL	26	rr	3
BPL <i>rel</i>	Branch if Plus	$PC \leftarrow (PC) + 2 + rel ? (N) = 0$	-	-	-	-	-	-	REL	2A	rr	3
BRA <i>rel</i>	Branch Always	$PC \leftarrow (PC) + 2 + rel$	-	-	-	-	-	-	REL	20	rr	3

Table 6-1. Instruction Set Summary

Source Form	Operation	Description	Effect on CCR						Address Mode	Opcode	Operand	Cycles	
			V	H	I	N	Z	C					
BRCLR <i>n,opr,rel</i>	Branch if Bit <i>n</i> in M Clear	$PC \leftarrow (PC) + 3 + rel ? (Mn) = 0$	-	-	-	-	-	↓	DIR (b0)	01	dd rr	5	
			-	-	-	-	-	-	↓	DIR (b1)	03	dd rr	5
			-	-	-	-	-	-	↓	DIR (b2)	05	dd rr	5
			-	-	-	-	-	-	↓	DIR (b3)	07	dd rr	5
			-	-	-	-	-	-	↓	DIR (b4)	09	dd rr	5
			-	-	-	-	-	-	↓	DIR (b5)	0B	dd rr	5
			-	-	-	-	-	-	↓	DIR (b6)	0D	dd rr	5
BRN <i>rel</i>	Branch Never	$PC \leftarrow (PC) + 2$	-	-	-	-	-	REL	21	rr	3		
BRSET <i>n,opr,rel</i>	Branch if Bit <i>n</i> in M Set	$PC \leftarrow (PC) + 3 + rel ? (Mn) = 1$	-	-	-	-	-	↓	DIR (b0)	00	dd rr	5	
			-	-	-	-	-	-	↓	DIR (b1)	02	dd rr	5
			-	-	-	-	-	-	↓	DIR (b2)	04	dd rr	5
			-	-	-	-	-	-	↓	DIR (b3)	06	dd rr	5
			-	-	-	-	-	-	↓	DIR (b4)	08	dd rr	5
			-	-	-	-	-	-	↓	DIR (b5)	0A	dd rr	5
			-	-	-	-	-	-	↓	DIR (b6)	0C	dd rr	5
BSET <i>n,opr</i>	Set Bit <i>n</i> in M	$Mn \leftarrow 1$	-	-	-	-	-	-	DIR (b0)	10	dd	4	
			-	-	-	-	-	-	-	DIR (b1)	12	dd	4
			-	-	-	-	-	-	-	DIR (b2)	14	dd	4
			-	-	-	-	-	-	-	DIR (b3)	16	dd	4
			-	-	-	-	-	-	-	DIR (b4)	18	dd	4
			-	-	-	-	-	-	-	DIR (b5)	1A	dd	4
			-	-	-	-	-	-	-	DIR (b6)	1C	dd	4
BSR <i>rel</i>	Branch to Subroutine	$PC \leftarrow (PC) + 2$; push (PCL) $SP \leftarrow (SP) - 1$; push (PCH) $SP \leftarrow (SP) - 1$ $PC \leftarrow (PC) + rel$	-	-	-	-	-	-	REL	AD	rr	4	
			-	-	-	-	-	-	-	DIR	31	dd rr	5
			-	-	-	-	-	-	-	IMM	41	ii rr	4
			-	-	-	-	-	-	-	IMM	51	ii rr	4
			-	-	-	-	-	-	-	IX1+	61	ff rr	5
			-	-	-	-	-	-	-	IX+	71	rr	4
			-	-	-	-	-	-	-	SP1	9E61	ff rr	6
CLC	Clear Carry Bit	$C \leftarrow 0$	-	-	-	-	0	INH	98		1		
CLI	Clear Interrupt Mask	$I \leftarrow 0$	-	-	0	-	-	INH	9A		2		
CLR <i>opr</i> CLRA CLR X CLR H CLR <i>opr,X</i> CLR ,X CLR <i>opr,SP</i>	Clear	$M \leftarrow \$00$ $A \leftarrow \$00$ $X \leftarrow \$00$ $H \leftarrow \$00$ $M \leftarrow \$00$ $M \leftarrow \$00$ $M \leftarrow \$00$	-	-	-	-	-	-	DIR	3F	dd	3	
			-	-	-	-	-	-	-	INH	4F		1
			-	-	-	-	-	-	-	INH	5F		1
			0	-	-	0	1	-	-	INH	8C		1
			-	-	-	-	-	-	-	IX1	6F	ff	3
			-	-	-	-	-	-	-	IX	7F		2
			-	-	-	-	-	-	-	SP1	9E6F	ff	4

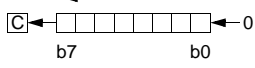
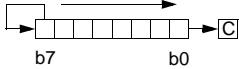
Table 6-1. Instruction Set Summary

Source Form	Operation	Description	Effect on CCR						Address Mode	Opcode	Operand	Cycles
			V	H	I	N	Z	C				
CMP #opr CMP opr CMP opr CMP opr,X CMP opr,X CMP ,X CMP opr,SP CMP opr,SP	Compare A with M	(A) – (M)	↑	–	–	↑	↑	↑	IMM DIR EXT IX2 IX1 IX SP1 SP2	A1 B1 C1 D1 E1 F1 9EE1 9ED1	ii dd hh ll ee ff ff ff ff ee ff	2 3 4 4 3 2 4 5
COM opr COMA COMX COM opr,X COM ,X COM opr,SP	Complement (One's Complement)	$M \leftarrow \overline{(M)} = \$FF - (M)$ $A \leftarrow \overline{(A)} = \$FF - (M)$ $X \leftarrow \overline{(X)} = \$FF - (M)$ $M \leftarrow \overline{(M)} = \$FF - (M)$ $M \leftarrow \overline{(M)} = \$FF - (M)$ $M \leftarrow \overline{(M)} = \$FF - (M)$	0	–	–	↑	↑	1	DIR INH INH IX1 IX SP1	33 43 53 63 73 9E63	dd ff ff ff ff	4 1 1 4 3 5
CPHX #opr CPHX opr	Compare H:X with M	(H:X) – (M:M + 1)	↑	–	–	↑	↑	↑	IMM DIR	65 75	ii ii+1 dd	3 4
CPX #opr CPX opr CPX opr CPX ,X CPX opr,X CPX opr,X CPX opr,SP CPX opr,SP	Compare X with M	(X) – (M)	↑	–	–	↑	↑	↑	IMM DIR EXT IX2 IX1 IX SP1 SP2	A3 B3 C3 D3 E3 F3 9EE3 9ED3	ii dd hh ll ee ff ff ff ff ee ff	2 3 4 4 3 2 4 5
DAA	Decimal Adjust A	(A) ₁₀	U	–	–	↑	↑	↑	INH	72		2
DBNZ opr,rel DBNZA rel DBNZX rel DBNZ opr,X,rel DBNZ X,rel DBNZ opr,SP,rel	Decrement and Branch if Not Zero	$A \leftarrow (A) - 1$ or $M \leftarrow (M) - 1$ or $X \leftarrow (X) - 1$ $PC \leftarrow (PC) + 3 + rel ? (result) \neq 0$ $PC \leftarrow (PC) + 2 + rel ? (result) \neq 0$ $PC \leftarrow (PC) + 2 + rel ? (result) \neq 0$ $PC \leftarrow (PC) + 3 + rel ? (result) \neq 0$ $PC \leftarrow (PC) + 2 + rel ? (result) \neq 0$ $PC \leftarrow (PC) + 4 + rel ? (result) \neq 0$	–	–	–	–	–	–	DIR INH INH IX1 IX SP1	3B 4B 5B 6B 7B 9E6B	dd rr rr rr ff rr rr ff rr	5 3 3 5 4 6
DEC opr DECA DECX DEC opr,X DEC ,X DEC opr,SP	Decrement	$M \leftarrow (M) - 1$ $A \leftarrow (A) - 1$ $X \leftarrow (X) - 1$ $M \leftarrow (M) - 1$ $M \leftarrow (M) - 1$ $M \leftarrow (M) - 1$	↑	–	–	↑	↑	–	DIR INH INH IX1 IX SP1	3A 4A 5A 6A 7A 9E6A	dd ff ff ff ff	4 1 1 4 3 5
DIV	Divide	$A \leftarrow (H:A)/(X)$ $H \leftarrow \text{Remainder}$	–	–	–	–	↑	↑	INH	52		7

Table 6-1. Instruction Set Summary

Source Form	Operation	Description	Effect on CCR						Address Mode	Opcode	Operand	Cycles
			V	H	I	N	Z	C				
EOR #opr EOR opr EOR opr EOR opr,X EOR opr,X EOR ,X EOR opr,SP EOR opr,SP	Exclusive OR M with A	$A \leftarrow (A \oplus M)$	0	-	-	↑	↑	-	IMM DIR EXT IX2 IX1 IX SP1 SP2	A8 B8 C8 D8 E8 F8 9EE8 9ED8	ii dd hh ll ee ff ff ff ff ee ff	2 3 4 4 3 2 4 5
INC opr INCA INCX INC opr,X INC ,X INC opr,SP	Increment	$M \leftarrow (M) + 1$ $A \leftarrow (A) + 1$ $X \leftarrow (X) + 1$ $M \leftarrow (M) + 1$ $M \leftarrow (M) + 1$ $M \leftarrow (M) + 1$	↑	-	-	↑	↑	-	DIR INH INH IX1 IX SP1	3C 4C 5C 6C 7C 9E6C	dd ff ff ff	4 1 1 4 3 5
JMP opr JMP opr JMP opr,X JMP opr,X JMP ,X	Jump	$PC \leftarrow \text{Jump Address}$	-	-	-	-	-	-	DIR EXT IX2 IX1 IX	BC CC DC EC FC	dd hh ll ee ff ff	2 3 4 3 2
JSR opr JSR opr JSR opr,X JSR opr,X JSR ,X	Jump to Subroutine	$PC \leftarrow (PC) + n$ ($n = 1, 2, \text{ or } 3$) Push (PCL); $SP \leftarrow (SP) - 1$ Push (PCH); $SP \leftarrow (SP) - 1$ $PC \leftarrow \text{Unconditional Address}$	-	-	-	-	-	-	DIR EXT IX2 IX1 IX	BD CD DD ED FD	dd hh ll ee ff ff	4 5 6 5 4
LDA #opr LDA opr LDA opr LDA opr,X LDA opr,X LDA ,X LDA opr,SP LDA opr,SP	Load A from M	$A \leftarrow (M)$	0	-	-	↑	↑	-	IMM DIR EXT IX2 IX1 IX SP1 SP2	A6 B6 C6 D6 E6 F6 9EE6 9ED6	ii dd hh ll ee ff ff ff ff ee ff	2 3 4 4 3 2 4 5
LDHX #opr LDHX opr	Load H:X from M	$H:X \leftarrow (M:M + 1)$	0	-	-	↑	↑	-	IMM DIR	45 55	ii jj dd	3 4
LDX #opr LDX opr LDX opr LDX opr,X LDX opr,X LDX ,X LDX opr,SP LDX opr,SP	Load X from M	$X \leftarrow (M)$	0	-	-	↑	↑	-	IMM DIR EXT IX2 IX1 IX SP1 SP2	AE BE CE DE EE FE 9EEE 9EDE	ii dd hh ll ee ff ff ff ff ee ff	2 3 4 4 3 2 4 5
LSL opr LSLA LSLX LSL opr,X LSL ,X LSL opr,SP	Logical Shift Left (Same as ASL)		↑	-	-	↑	↑	↑	DIR INH INH IX1 IX SP1	38 48 58 68 78 9E68	dd ff ff ff	4 1 1 4 3 5

Table 6-1. Instruction Set Summary

Source Form	Operation	Description	Effect on CCR						Address Mode	Opcode	Operand	Cycles
			V	H	I	N	Z	C				
LSR <i>opr</i> LSRA LSRX LSR <i>opr,X</i> LSR ,X LSR <i>opr,SP</i>	Logical Shift Right		↑	-	-	0	↑	↓	DIR INH INH IX1 IX SP1	34 44 54 64 74 9E64	dd ff ff	4 1 1 4 3 5
MOV <i>opr,opr</i> MOV <i>opr,X+</i> MOV # <i>opr,opr</i> MOV X+, <i>opr</i>	Move	(M) _{Destination} ← (M) _{Source} H:X ← (H:X) + 1 (IX+D, DIX+)	0	-	-	↑	↑	-	DD DIX+ IMD IX+D	4E 5E 6E 7E	dd dd dd ii dd dd	5 4 4 4
MUL	Unsigned multiply	X:A ← (X) × (A)	-	0	-	-	-	0	INH	42		5
NEG <i>opr</i> NEGA NEGX NEG <i>opr,X</i> NEG ,X NEG <i>opr,SP</i>	Negate (Two's Complement)	M ← -(M) = \$00 - (M) A ← -(A) = \$00 - (A) X ← -(X) = \$00 - (X) M ← -(M) = \$00 - (M) M ← -(M) = \$00 - (M)	↑	-	-	↑	↑	↓	DIR INH INH IX1 IX SP1	30 40 50 60 70 9E60	dd ff ff	4 1 1 4 3 5
NOP	No Operation	None	-	-	-	-	-	-	INH	9D		1
NSA	Nibble Swap A	A ← (A[3:0]:A[7:4])	-	-	-	-	-	-	INH	62		3
ORA # <i>opr</i> ORA <i>opr</i> ORA <i>opr</i> ORA <i>opr,X</i> ORA <i>opr,X</i> ORA ,X ORA <i>opr,SP</i> ORA <i>opr,SP</i>	Inclusive OR A and M	A ← (A) (M)	0	-	-	↑	↑	-	IMM DIR EXT IX2 IX1 IX SP1 SP2	AA BA CA DA EA FA 9EEA 9EDA	ii dd hh ll ee ff ff ff ff ee ff	2 3 4 4 3 2 4 5
PSHA	Push A onto Stack	Push (A); SP ← (SP) - 1	-	-	-	-	-	-	INH	87		2
PSHH	Push H onto Stack	Push (H); SP ← (SP) - 1	-	-	-	-	-	-	INH	8B		2
PSHX	Push X onto Stack	Push (X); SP ← (SP) - 1	-	-	-	-	-	-	INH	89		2
PULA	Pull A from Stack	SP ← (SP + 1); Pull (A)	-	-	-	-	-	-	INH	86		2
PULH	Pull H from Stack	SP ← (SP + 1); Pull (H)	-	-	-	-	-	-	INH	8A		2
PULX	Pull X from Stack	SP ← (SP + 1); Pull (X)	-	-	-	-	-	-	INH	88		2
ROL <i>opr</i> ROLA ROLX ROL <i>opr,X</i> ROL ,X ROL <i>opr,SP</i>	Rotate Left through Carry		↑	-	-	↑	↑	↓	DIR INH INH IX1 IX SP1	39 49 59 69 79 9E69	dd ff ff	4 1 1 4 3 5

Table 6-1. Instruction Set Summary

Source Form	Operation	Description	Effect on CCR						Address Mode	Opcode	Operand	Cycles
			V	H	I	N	Z	C				
ROR <i>opr</i> RORA RORX ROR <i>opr,X</i> ROR <i>,X</i> ROR <i>opr,SP</i>	Rotate Right through Carry		↑	-	-	↑	↑	↑	DIR INH INH IX1 IX SP1	36 46 56 66 76 9E66	dd ff ff	4 1 1 4 3 5
RSP	Reset Stack Pointer	SP ← \$FF	-	-	-	-	-	-	INH	9C		1
RTI	Return from Interrupt	SP ← (SP) + 1; Pull (CCR) SP ← (SP) + 1; Pull (A) SP ← (SP) + 1; Pull (X) SP ← (SP) + 1; Pull (PCH) SP ← (SP) + 1; Pull (PCL)	↑	↑	↑	↑	↑	↑	INH	80		7
RTS	Return from Subroutine	SP ← SP + 1; Pull (PCH) SP ← SP + 1; Pull (PCL)	-	-	-	-	-	-	INH	81		4
SBC # <i>opr</i> SBC <i>opr</i> SBC <i>opr</i> SBC <i>opr,X</i> SBC <i>opr,X</i> SBC <i>,X</i> SBC <i>opr,SP</i> SBC <i>opr,SP</i>	Subtract with Carry	$A \leftarrow (A) - (M) - (C)$	↑	-	-	↑	↑	↑	IMM DIR EXT IX2 IX1 IX SP1 SP2	A2 B2 C2 D2 E2 F2 9EE2 9ED2	ii dd hh ll ee ff ff ff ff ee ff	2 3 4 4 3 2 4 5
SEC	Set Carry Bit	C ← 1	-	-	-	-	-	1	INH	99		1
SEI	Set Interrupt Mask	I ← 1	-	-	1	-	-	-	INH	9B		2
STA <i>opr</i> STA <i>opr</i> STA <i>opr,X</i> STA <i>opr,X</i> STA <i>,X</i> STA <i>opr,SP</i> STA <i>opr,SP</i>	Store A in M	M ← (A)	0	-	-	↑	↑	-	DIR EXT IX2 IX1 IX SP1 SP2	B7 C7 D7 E7 F7 9EE7 9ED7	dd hh ll ee ff ff ff ff ee ff	3 4 4 3 2 4 5
STHX <i>opr</i>	Store H:X in M	(M:M + 1) ← (H:X)	0	-	-	↑	↑	-	DIR	35	dd	4
STOP	Enable \overline{IRQ} Pin; Stop Oscillator	I ← 0; Stop Oscillator	-	-	0	-	-	-	INH	8E		1
STX <i>opr</i> STX <i>opr</i> STX <i>opr,X</i> STX <i>opr,X</i> STX <i>,X</i> STX <i>opr,SP</i> STX <i>opr,SP</i>	Store X in M	M ← (X)	0	-	-	↑	↑	-	DIR EXT IX2 IX1 IX SP1 SP2	BF CF DF EF FF 9EEF 9EDF	dd hh ll ee ff ff ff ff ee ff	3 4 4 3 2 4 5

Table 6-1. Instruction Set Summary

Source Form	Operation	Description	Effect on CCR						Address Mode	Opcode	Operand	Cycles
			V	H	I	N	Z	C				
SUB #opr SUB opr SUB opr SUB opr,X SUB opr,X SUB ,X SUB opr,SP SUB opr,SP	Subtract	$A \leftarrow (A) - (M)$	↓	-	-	↑	↑	↓	IMM DIR EXT IX2 IX1 IX SP1 SP2	A0 B0 C0 D0 E0 F0 9EE0 9ED0	ii dd hh ll ee ff ff ff ff ee ff	2 3 4 4 3 2 4 5
SWI	Software Interrupt	PC ← (PC) + 1; Push (PCL) SP ← (SP) - 1; Push (PCH) SP ← (SP) - 1; Push (X) SP ← (SP) - 1; Push (A) SP ← (SP) - 1; Push (CCR) SP ← (SP) - 1; I ← 1 PCH ← Interrupt Vector High Byte PCL ← Interrupt Vector Low Byte	-	-	1	-	-	-	INH	83		9
TAP	Transfer A to CCR	$CCR \leftarrow (A)$	↓	↓	↓	↓	↓	↓	INH	84		2
TAX	Transfer A to X	$X \leftarrow (A)$	-	-	-	-	-	-	INH	97		1
TPA	Transfer CCR to A	$A \leftarrow (CCR)$	-	-	-	-	-	-	INH	85		1
TST opr TSTA TSTX TST opr,X TST ,X TST opr,SP	Test for Negative or Zero	$(A) - \$00$ or $(X) - \$00$ or $(M) - \$00$	0	-	-	↑	↑	-	DIR INH INH IX1 IX SP1	3D 4D 5D 6D 7D 9E6D	dd ff ff	3 1 1 3 2 4
TSX	Transfer SP to H:X	$H:X \leftarrow (SP) + 1$	-	-	-	-	-	-	INH	95		2
TXA	Transfer X to A	$A \leftarrow (X)$	-	-	-	-	-	-	INH	9F		1
TXS	Transfer H:X to SP	$(SP) \leftarrow (H:X) - 1$	-	-	-	-	-	-	INH	94		2

Table 6-1. Instruction Set Summary

Source Form	Operation	Description	Effect on CCR						Address Mode	Opcode	Operand	Cycles
			V	H	I	N	Z	C				
A	Accumulator	<i>n</i>	Any bit									
C	Carry/borrow bit	<i>opr</i>	Operand (one or two bytes)									
CCR	Condition code register	PC	Program counter									
dd	Direct address of operand	PCH	Program counter high byte									
dd rr	Direct address of operand and relative offset of branch instruction	PCL	Program counter low byte									
DD	Direct to direct addressing mode	REL	Relative addressing mode									
DIR	Direct addressing mode	<i>rel</i>	Relative program counter offset byte									
DIX+	Direct to indexed with post increment addressing mode	rr	Relative program counter offset byte									
ee ff	High and low bytes of offset in indexed, 16-bit offset addressing	SP1	Stack pointer, 8-bit offset addressing mode									
EXT	Extended addressing mode	SP2	Stack pointer 16-bit offset addressing mode									
ff	Offset byte in indexed, 8-bit offset addressing	SP	Stack pointer									
H	Half-carry bit	U	Undefined									
H	Index register high byte	V	Overflow bit									
hh ll	High and low bytes of operand address in extended addressing	X	Index register low byte									
I	Interrupt mask	Z	Zero bit									
ii	Immediate operand byte	&	Logical AND									
IMD	Immediate source to direct destination addressing mode		Logical OR									
IMM	Immediate addressing mode	⊕	Logical EXCLUSIVE OR									
INH	Inherent addressing mode	()	Contents of									
IX	Indexed, no offset addressing mode	-()	Negation (two's complement)									
IX+	Indexed, no offset, post increment addressing mode	#	Immediate value									
IX+D	Indexed with post increment to direct addressing mode	«	Sign extend									
IX1	Indexed, 8-bit offset addressing mode	←	Loaded with									
IX1+	Indexed, 8-bit offset, post increment addressing mode	?	If									
IX2	Indexed, 16-bit offset addressing mode	:	Concatenated with									
M	Memory location	↑	Set or cleared									
N	Negative bit	—	Not affected									

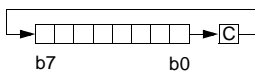
Table 6-2. Opcode Map

MSB LSB	Bit Manipulation			Branch			Read-Modify-Write			Control			Register/Memory											
	DIR	DIR	REL	DIR	DIR	REL	DIR	DIR	DIR	INH	IX1	SP1	IX	INH	INH	IMM	DIR	EXT	IX2	SP2	IX1	SP1	IX	
0	1	2	3	4	5	6	7	8	9	A	B	C	D	9ED	E	9EE	F							
5 3 3	BSET0 DIR	4 2	BRA REL	1 1	NEG INH	4 2	NEG IX1	3 3	NEG SP1	5 5	NEG SP1	3 3	NEG IX1	7 7	NEG IX1	3 3	BRA REL	4 4	NEG IX1	5 5	NEG SP1	3 3	NEG IX1	
5 3 3	BCLR0 DIR	4 2	BRN REL	4 3	CBEQ IMM	5 3	CBEQ IX1+	4 4	CBEQ SP1	6 6	CBEQ SP1	4 4	CBEQ IX1+	4 4	CBEQ IX1	2 2	BRN REL	4 4	CBEQ IX1	5 5	CBEQ SP1	4 4	CBEQ IX1	
5 3 3	BSET1 DIR	4 2	BHI REL	5 1	MUL INH	1 1	NSA INH	7 7	NSA INH	2 2	DAA INH	1 1	DAA INH	2 2	DAA INH	2 2	BSET1 REL	4 4	SBC IX2	5 5	SBC SP1	4 4	SBC IX2	
5 3 3	BCLR1 DIR	4 2	BLS REL	3 1	COMX INH	4 1	COM IX1	5 5	COM SP1	3 3	COM SP1	9 9	COM IX1	3 3	COM IX1	2 2	BCLR1 REL	4 4	CPX IX2	4 4	CPX SP1	3 3	CPX IX2	
5 3 3	BSET2 DIR	4 2	BCC REL	4 1	LSRX INH	4 1	LSR INH	5 5	LSR SP1	4 4	LSR SP1	2 2	LSR INH	4 4	LSR INH	2 2	BSET2 REL	4 4	AND IX2	5 5	AND SP1	4 4	AND IX2	
5 3 3	BCLR2 DIR	4 2	BCS REL	4 3	LDHX DIR	4 3	CPHX IMM	4 4	CPHX IMM	4 4	CPHX IMM	1 1	CPHX IMM	4 4	CPHX IMM	2 2	BCLR2 REL	4 4	BIT IX2	5 5	BIT SP1	3 3	BIT IX2	
5 3 3	BSET3 DIR	4 2	BNE REL	4 3	RORX INH	4 3	ROR IX1	5 5	ROR SP1	4 4	ROR SP1	1 1	ROR INH	4 4	ROR INH	2 2	BSET3 REL	4 4	LDA IX2	5 5	LDA SP1	3 3	LDA IX2	
5 3 3	BCLR3 DIR	4 2	BEQ REL	4 1	ASRX INH	4 1	ASR IX1	5 5	ASR SP1	3 3	ASR SP1	2 2	ASR INH	4 4	ASR INH	2 2	BCLR3 REL	4 4	STA IX2	5 5	STA SP1	3 3	STA IX2	
5 3 3	BSET4 DIR	4 2	BHCC REL	4 1	LSLX INH	4 1	LSL IX1	5 5	LSL SP1	3 3	LSL SP1	2 2	LSL INH	4 4	LSL INH	2 2	BSET4 REL	4 4	EOR IX2	5 5	EOR SP1	3 3	EOR IX2	
5 3 3	BCLR4 DIR	4 2	BHCS REL	4 1	ROLX INH	4 1	ROL IX1	5 5	ROL SP1	3 3	ROL SP1	2 2	ROL INH	4 4	ROL INH	2 2	BCLR4 REL	4 4	ADC IX2	5 5	ADC SP1	3 3	ADC IX2	
5 3 3	BSET5 DIR	4 2	BPL REL	4 1	DECX INH	4 1	DEC IX1	5 5	DEC SP1	3 3	DEC SP1	2 2	DEC INH	4 4	DEC INH	2 2	BSET5 REL	4 4	ORA IX2	5 5	ORA SP1	3 3	ORA IX2	
5 3 3	BCLR5 DIR	4 2	BMI REL	5 3	DBNZX INH	5 3	DBNZ IX1	6 6	DBNZ SP1	4 4	DBNZ SP1	2 2	DBNZ INH	5 5	DBNZ INH	2 2	BCLR5 REL	4 4	ADC IX2	5 5	ADC SP1	3 3	ADC IX2	
5 3 3	BSET6 DIR	4 2	BMC REL	4 1	INCX INH	4 1	INC IX1	5 5	INC SP1	3 3	INC SP1	2 2	INC INH	4 4	INC INH	2 2	BSET6 REL	4 4	ORA IX2	5 5	ORA SP1	3 3	ORA IX2	
5 3 3	BCLR6 DIR	4 2	BMS REL	3 3	TSTX INH	3 3	TST IX1	4 4	TST SP1	2 2	TST SP1	1 1	TST INH	3 3	TST INH	2 2	BCLR6 REL	4 4	JSR IX2	5 5	JSR SP1	3 3	JSR IX2	
5 3 3	BSET7 DIR	4 2	BIL REL	5 3	MOVX DIR	5 3	MOV IX1+	4 4	MOV SP1	2 2	MOV SP1	1 1	MOV INH	3 3	MOV INH	2 2	BSET7 REL	4 4	LDX IX2	5 5	LDX SP1	3 3	LDX IX2	
5 3 3	BCLR7 DIR	4 2	BIH REL	4 1	CLRX INH	4 1	CLR IX1	5 5	CLR SP1	3 3	CLR SP1	2 2	CLR INH	4 4	CLR INH	2 2	BCLR7 REL	4 4	STX IX2	5 5	STX SP1	3 3	STX IX2	

INH Inherent
 IMM Immediate
 DIR Direct
 EXT Extended
 DD Direct-Direct
 IX+D Indexed-Direct
 * Pre-byte for stack pointer indexed instructions

REL Relative Indexed, No Offset
 IX Indexed, 8-Bit Offset
 IX1 Indexed, 8-Bit Offset
 IX2 Indexed, 16-Bit Offset
 IMM Immediate-Direct
 IX+D Indexed-Direct

SP1 Stack Pointer, 8-Bit Offset
 SP2 Stack Pointer, 16-Bit Offset
 IX+ Post Increment
 IX1+ Indexed, 1-Byte Offset with Post Increment
 IX+D Indexed, 1-Byte Offset with Post Increment

MSB 0
 LSB 0

High Byte of Opcode in Hexadecimal
 Cycles Opcode Mnemonic
 Number of Bytes / Addressing Mode

Low Byte of Opcode in Hexadecimal
 BRSET0
 DIR



EEPW 电子产品世界
.com.cn

Section 7. System Integration Module (SIM)

7.1 Contents

7.2	Introduction	66
7.3	SIM Bus Clock Control and Generation	69
7.3.1	Bus Timing	69
7.3.2	Clock Start-Up from POR	69
7.3.3	Clocks in Stop Mode and Wait Mode	69
7.4	Reset and System Initialization	70
7.4.1	External Pin Reset	70
7.4.2	Active Resets from Internal Sources	71
7.4.2.1	Power-On Reset	72
7.4.2.2	Computer Operating Properly (COP) Reset	73
7.4.2.3	Illegal Opcode Reset	73
7.4.2.4	Illegal Address Reset	73
7.4.2.5	LVI Reset	74
7.5	SIM Counter	74
7.5.1	SIM Counter During Power-On Reset	74
7.5.2	SIM Counter During Stop Mode Recovery	74
7.5.3	SIM Counter and Reset States	75
7.6	Exception Control	75
7.6.1	Interrupts	75
7.6.1.1	Hardware Interrupts	77
7.6.1.2	SWI Instruction	79
7.6.2	Interrupt Status Registers	79
7.6.2.1	Interrupt Status Register 1	80
7.6.2.2	Interrupt Status Register 2	80
7.6.2.3	Interrupt Status Register 3	81
7.6.3	Reset	81
7.6.4	Break Interrupts	81
7.6.5	Status Flag Protection in Break Mode	81

7.7	Low-Power Modes	82
7.7.1	Wait Mode	82
7.7.2	Stop Mode	84
7.8	SIM Registers	85
7.8.1	Break Status Register (BSR)	85
7.8.2	Reset Status Register (RSR)	86
7.8.3	Break Flag Control Register (BFCR)	88

7.2 Introduction

This section describes the system integration module (SIM), which supports up to 24 external and/or internal interrupts. Together with the CPU, the SIM controls all MCU activities. A block diagram of the SIM is shown in [Figure 7-1](#). [Figure 7-2](#) is a summary of the SIM I/O registers. The SIM is a system state controller that coordinates CPU and exception timing. The SIM is responsible for:

- Bus clock generation and control for CPU and peripherals
 - Stop/wait/reset/break entry and recovery
 - Internal clock control
- Master reset control, including power-on reset (POR) and COP timeout
- Interrupt control:
 - Acknowledge timing
 - Arbitration control timing
 - Vector address generation
- CPU enable/disable timing
- Modular architecture expandable to 128 interrupt sources

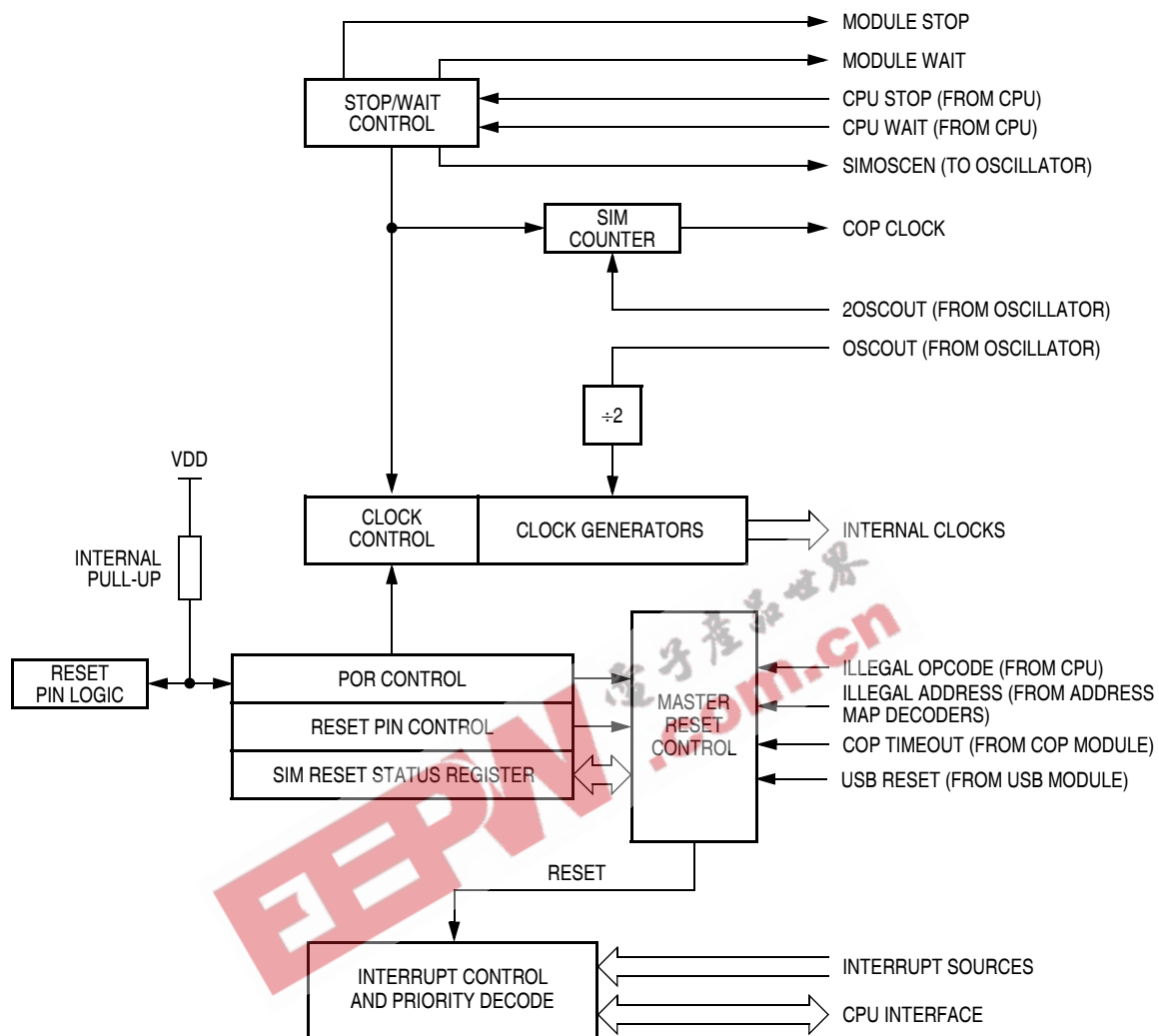

Figure 7-1. SIM Block Diagram

Table 7-1. Signal Name Conventions

Signal Name	Description
2OSCOUT	Buffered clock from the X-tal oscillator circuit or the RC oscillator circuit.
OSCOUT	The 2OSCOUT frequency divided by two. This signal is again divided by two in the SIM to generate the internal bus clocks. (Bus clock = 2OSCOUT ÷ 4)
IAB	Internal address bus
IDB	Internal data bus
PORRST	Signal from the power-on reset module to the SIM
IRST	Internal reset signal
R/ \bar{W}	Read/write signal

Addr.	Register Name	Bit 7	6	5	4	3	2	1	Bit 0	
\$FE00	Break Status Register (BSR)	Read:	R	R	R	R	R	SBSW	R	
		Write:						NOTE		
		Reset:	0	0	0	0	0	0	0	
Note: Writing a logic 0 clears SBSW.										
\$FE01	Reset Status Register (RSR)	Read:	POR	PIN	COP	ILOP	ILAD	MODRST	LVI	0
		Write:								
		POR:	1	0	0	0	0	0	0	0
\$FE02	Reserved	Read:	R	R	R	R	R	R	R	R
		Write:								
		Reset:								
\$FE03	Break Flag Control Register (BFCR)	Read:	BCFE	R	R	R	R	R	R	R
		Write:								
		Reset:	0							
\$FE04	Interrupt Status Register 1 (INT1)	Read:	0	IF5	IF4	IF3	0	IF1	0	0
		Write:	R	R	R	R	R	R	R	R
		Reset:	0	0	0	0	0	0	0	0
\$FE05	Interrupt Status Register 2 (INT2)	Read:	IF14	0	0	0	0	0	0	0
		Write:	R	R	R	R	R	R	R	R
		Reset:	0	0	0	0	0	0	0	0
\$FE06	Interrupt Status Register 3 (INT3)	Read:	0	0	0	0	0	0	0	IF15
		Write:	R	R	R	R	R	R	R	R
		Reset:	0	0	0	0	0	0	0	0

= Unimplemented
 R = Reserved

Figure 7-2. SIM I/O Register Summary

7.3 SIM Bus Clock Control and Generation

The bus clock generator provides system clock signals for the CPU and peripherals on the MCU. The system clocks are generated from an incoming clock, OSCOUT, as shown in [Figure 7-3](#).

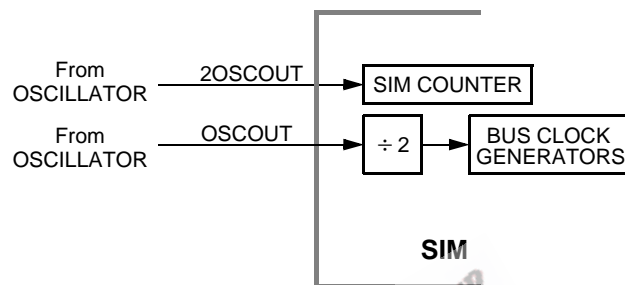

Figure 7-3. SIM Clock Signals

7.3.1 Bus Timing

In user mode, the internal bus frequency is the oscillator frequency (2OSCOUT) divided by four.

7.3.2 Clock Start-Up from POR

When the power-on reset module generates a reset, the clocks to the CPU and peripherals are inactive and held in an inactive phase until after the 4096 2OSCOUT cycle POR time-out has completed. The $\overline{\text{RST}}$ pin is driven low by the SIM during this entire period. The IBUS clocks start upon completion of the time-out.

7.3.3 Clocks in Stop Mode and Wait Mode

Upon exit from stop mode by an interrupt, break, or reset, the SIM allows 2OSCOUT to clock the SIM counter. The CPU and peripheral clocks do not become active until after the stop delay time-out. This time-out is selectable as 4096 or 32 2OSCOUT cycles. (See [7.7.2 Stop Mode](#).)

In wait mode, the CPU clocks are inactive. The SIM also produces two sets of clocks for other modules. Refer to the wait mode subsection of each module to see if the module is active or inactive in wait mode. Some modules can be programmed to be active in wait mode.

7.4 Reset and System Initialization

The MCU has these reset sources:

- Power-on reset module (POR)
- External reset pin (\overline{RST})
- Computer operating properly module (COP)
- Low-voltage inhibit module (LVI)
- Illegal opcode
- Illegal address

All of these resets produce the vector \$FFFE–FFFF (\$FEFE–FEFF in Monitor mode) and assert the internal reset signal (IRST). IRST causes all registers to be returned to their default values and all modules to be returned to their reset states.

An internal reset clears the SIM counter (see [7.5 SIM Counter](#)), but an external reset does not. Each of the resets sets a corresponding bit in the reset status register (RSR). (See [7.8 SIM Registers](#).)

7.4.1 External Pin Reset

The \overline{RST} pin circuits include an internal pull-up device. Pulling the asynchronous \overline{RST} pin low halts all processing. The PIN bit of the reset status register (RSR) is set as long as \overline{RST} is held low for a minimum of 67 2OSCCLK cycles, assuming that the POR was not the source of the reset. See [Table 7-2](#) for details. [Figure 7-4](#) shows the relative timing.

Table 7-2. PIN Bit Set Timing

Reset Type	Number of Cycles Required to Set PIN
POR	4163 (4096 + 64 + 3)
All others	67 (64 + 3)

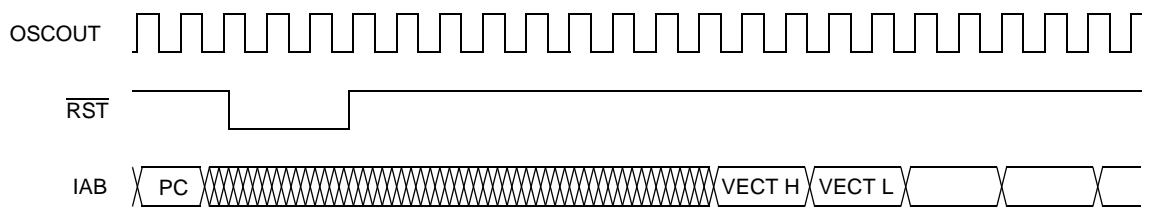

Figure 7-4. External Reset Timing

7.4.2 Active Resets from Internal Sources

All internal reset sources actively pull the $\overline{\text{RST}}$ pin low for 32 2OSCOUT cycles to allow resetting of external peripherals. The internal reset signal IRST continues to be asserted for an additional 32 cycles (Figure 7-5). An internal reset can be caused by an illegal address, illegal opcode, COP time-out, or POR. (See Figure 7-6 . Sources of Internal Reset.) Note that for POR resets, the SIM cycles through 4096 2OSCOUT cycles during which the SIM forces the $\overline{\text{RST}}$ pin low. The internal reset signal then follows the sequence from the falling edge of $\overline{\text{RST}}$ shown in Figure 7-5.

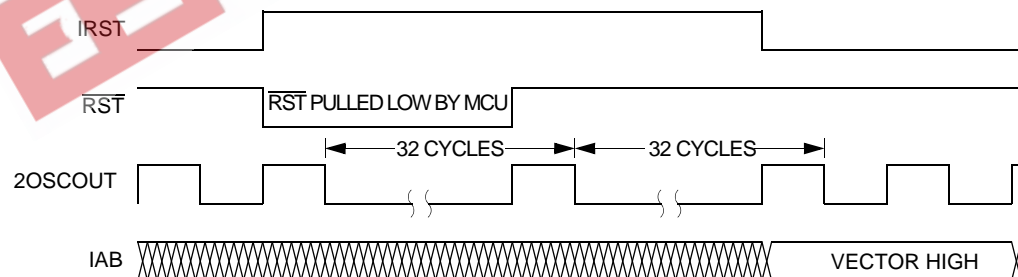

Figure 7-5. Internal Reset Timing

The COP reset is asynchronous to the bus clock.

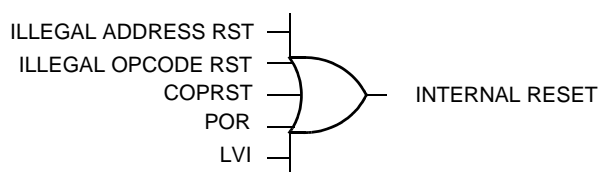

Figure 7-6. Sources of Internal Reset

The active reset feature allows the part to issue a reset to peripherals and other chips within a system built around the MCU.

7.4.2.1 Power-On Reset

When power is first applied to the MCU, the power-on reset module (POR) generates a pulse to indicate that power-on has occurred. The external reset pin ($\overline{\text{RST}}$) is held low while the SIM counter counts out 4096 2OSCOUT cycles. Sixty-four 2OSCOUT cycles later, the CPU and memories are released from reset to allow the reset vector sequence to occur.

At power-on, the following events occur:

- A POR pulse is generated.
- The internal reset signal is asserted.
- The SIM enables the oscillator to drive 2OSCOUT.
- Internal clocks to the CPU and modules are held inactive for 4096 2OSCOUT cycles to allow stabilization of the oscillator.
- The $\overline{\text{RST}}$ pin is driven low during the oscillator stabilization time.
- The POR bit of the reset status register (RSR) is set and all other bits in the register are cleared.

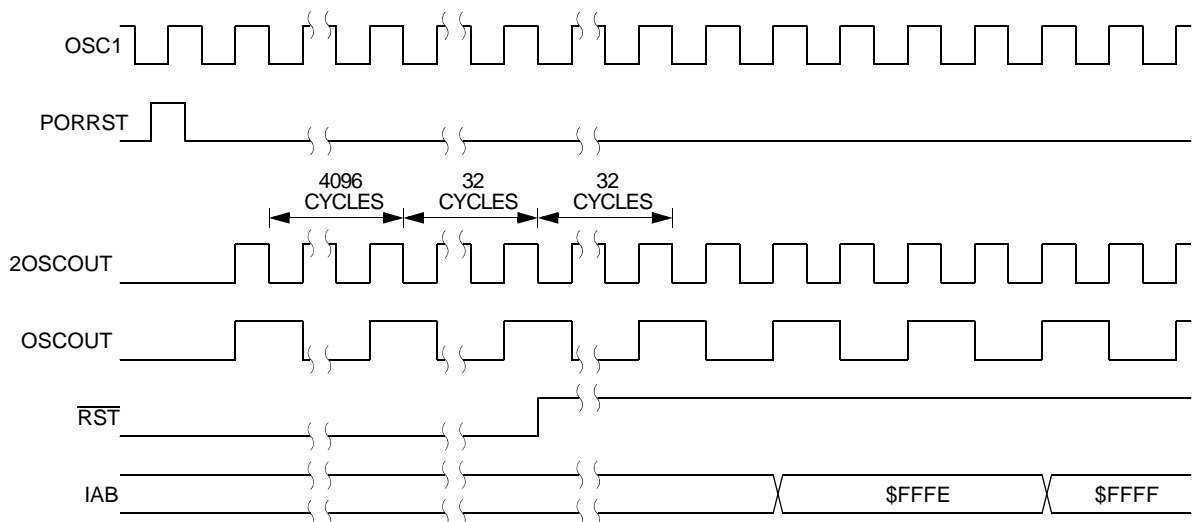

Figure 7-7. POR Recovery

7.4.2.2 Computer Operating Properly (COP) Reset

An input to the SIM is reserved for the COP reset signal. The overflow of the COP counter causes an internal reset and sets the COP bit in the reset status register (RSR). The SIM actively pulls down the $\overline{\text{RST}}$ pin for all internal reset sources.

To prevent a COP module time-out, write any value to location \$FFFF. Writing to location \$FFFF clears the COP counter and stages 12 through 5 of the SIM counter. The SIM counter output, which occurs at least every $(2^{12} - 2^4)$ 2OSCOUT cycles, drives the COP counter. The COP should be serviced as soon as possible out of reset to guarantee the maximum amount of time before the first time-out.

The COP module is disabled if the $\overline{\text{RST}}$ pin or the $\overline{\text{IRQ1}}$ pin is held at $V_{\text{DD}} + V_{\text{HI}}$ while the MCU is in monitor mode. The COP module can be disabled only through combinational logic conditioned with the high voltage signal on the $\overline{\text{RST}}$ or the $\overline{\text{IRQ1}}$ pin. This prevents the COP from becoming disabled as a result of external noise. During a break state, $V_{\text{DD}} + V_{\text{HI}}$ on the $\overline{\text{RST}}$ pin disables the COP module.

7.4.2.3 Illegal Opcode Reset

The SIM decodes signals from the CPU to detect illegal instructions. An illegal instruction sets the ILOP bit in the reset status register (RSR) and causes a reset.

If the stop enable bit, STOP, in the mask option register is logic zero, the SIM treats the STOP instruction as an illegal opcode and causes an illegal opcode reset. The SIM actively pulls down the $\overline{\text{RST}}$ pin for all internal reset sources.

7.4.2.4 Illegal Address Reset

An opcode fetch from an unmapped address generates an illegal address reset. The SIM verifies that the CPU is fetching an opcode prior to asserting the ILAD bit in the reset status register (RSR) and resetting the MCU. A data fetch from an unmapped address does not generate a reset. The SIM actively pulls down the $\overline{\text{RST}}$ pin for all internal reset sources.

7.4.2.5 LVI Reset

The low-voltage inhibit module (LVI) asserts its output to the SIM when the V_{DD} voltage falls to the LVI trip voltage V_{TRIP} . The LVI bit in the SIM reset status register (SRSR) is set, and the external reset pin (RSTB) is held low while the SIM counter counts out 4096 2OSCCLK cycles. Sixty-four 2OSCOU cycles later, the CPU and memories are released from reset to allow the reset vector sequence to occur. The SIM actively pulls down the (RSTB) pin for all internal reset sources.

7.5 SIM Counter

The SIM counter is used by the power-on reset module (POR) and in stop mode recovery to allow the oscillator time to stabilize before enabling the internal bus (IBUS) clocks. The SIM counter also serves as a prescaler for the computer operating properly module (COP). The SIM counter uses 12 stages for counting, followed by a 13th stage that triggers a reset of SIM counters and supplies the clock for the COP module. The SIM counter is clocked by the falling edge of 2OSCOU.

7.5.1 SIM Counter During Power-On Reset

The power-on reset module (POR) detects power applied to the MCU. At power-on, the POR circuit asserts the signal PORRST. Once the SIM is initialized, it enables the oscillator to drive the bus clock state machine.

7.5.2 SIM Counter During Stop Mode Recovery

The SIM counter also is used for stop mode recovery. The STOP instruction clears the SIM counter. After an interrupt, break, or reset, the SIM senses the state of the short stop recovery bit, SSREC, in the mask option register. If the SSREC bit is a logic one, then the stop recovery is reduced from the normal delay of 4096 2OSCOU cycles down to 32 2OSCOU cycles. This is ideal for applications using canned oscillators that do not require long start-up times from stop mode. External crystal applications should use the full stop recovery time, that is, with SSREC cleared in the configuration register (CONFIG).

7.5.3 SIM Counter and Reset States

External reset has no effect on the SIM counter. (See [7.7.2 Stop Mode](#) for details.) The SIM counter is free-running after all reset states. (See [7.4.2 Active Resets from Internal Sources](#) for counter control and internal reset recovery sequences.)

7.6 Exception Control

Normal, sequential program execution can be changed in three different ways:

- Interrupts
 - Maskable hardware CPU interrupts
 - Non-maskable software interrupt instruction (SWI)
- Reset
- Break interrupts

7.6.1 Interrupts

An interrupt temporarily changes the sequence of program execution to respond to a particular event. [Figure 7-8](#) flow charts the handling of system interrupts.

Interrupts are latched, and arbitration is performed in the SIM at the start of interrupt processing. The arbitration result is a constant that the CPU uses to determine which vector to fetch. Once an interrupt is latched by the SIM, no other interrupt can take precedence, regardless of priority, until the latched interrupt is serviced (or the I bit is cleared).

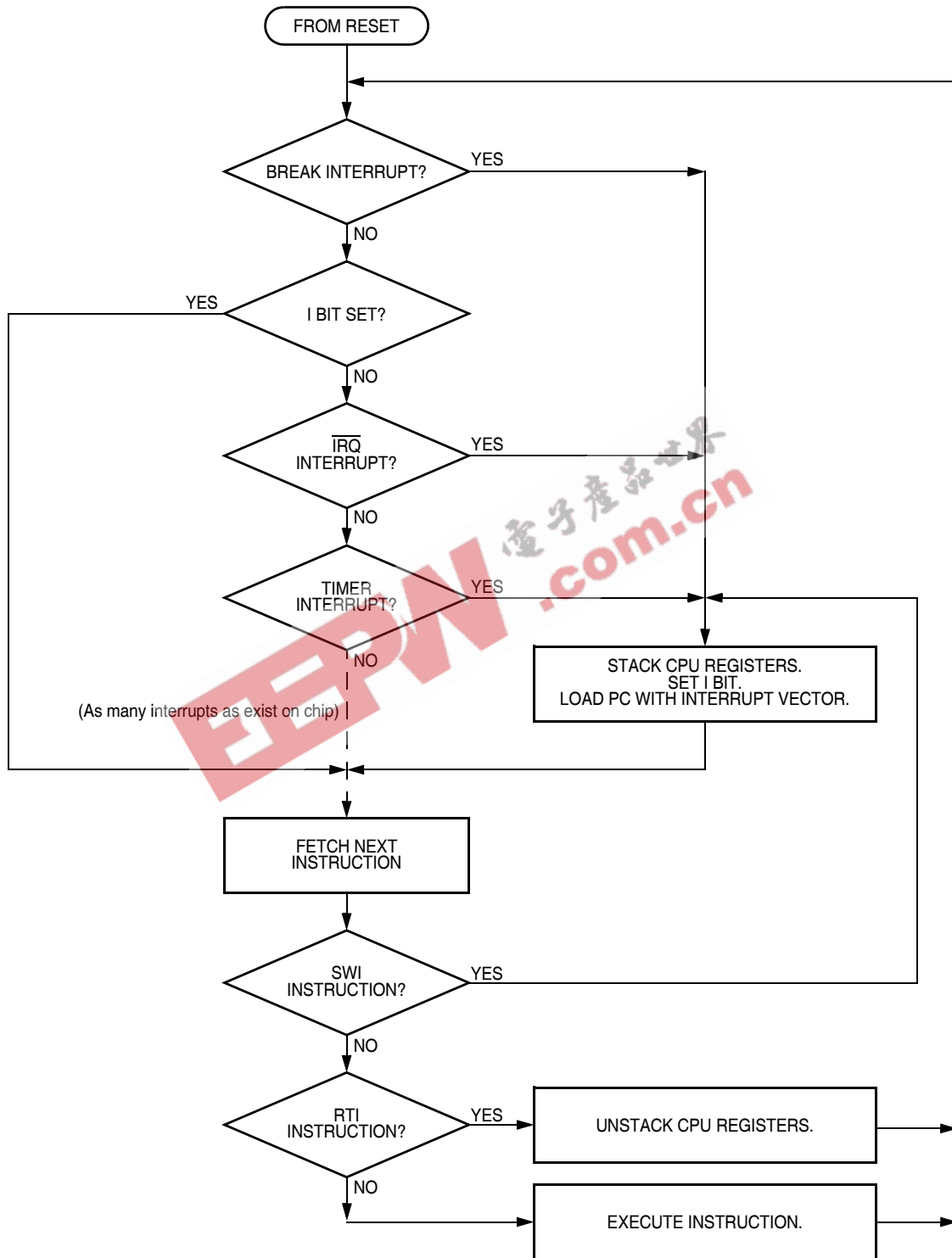

Figure 7-8. Interrupt Processing

At the beginning of an interrupt, the CPU saves the CPU register contents on the stack and sets the interrupt mask (I bit) to prevent additional interrupts. At the end of an interrupt, the RTI instruction recovers the CPU register contents from the stack so that normal processing can resume. **Figure 7-9** shows interrupt entry timing. **Figure 7-10** shows interrupt recovery timing.

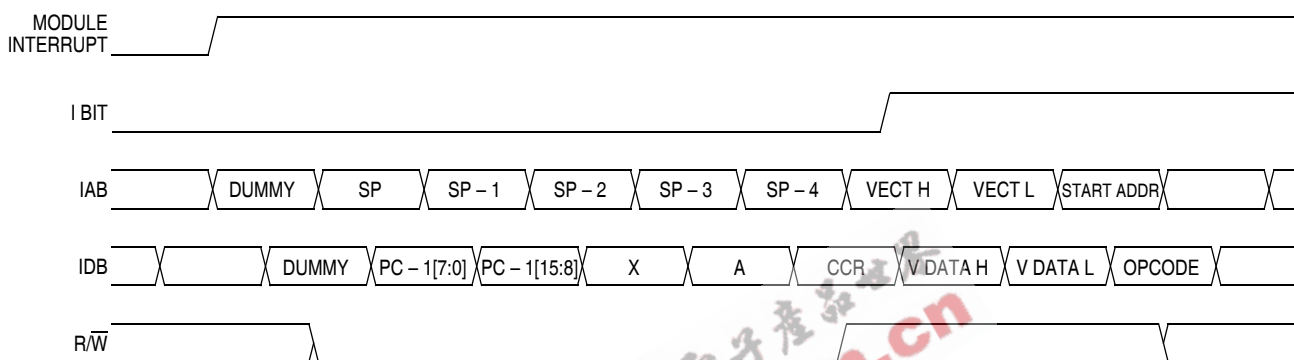

Figure 7-9. Interrupt Entry

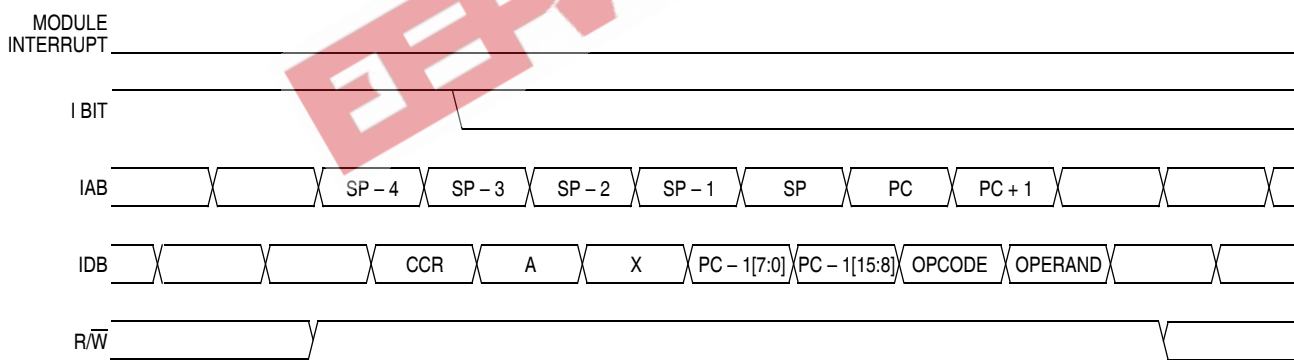

Figure 7-10. Interrupt Recovery

7.6.1.1 Hardware Interrupts

A hardware interrupt does not stop the current instruction. Processing of a hardware interrupt begins after completion of the current instruction. When the current instruction is complete, the SIM checks all pending hardware interrupts. If interrupts are not masked (I bit clear in the condition code register), and if the corresponding interrupt enable bit is

set, the SIM proceeds with interrupt processing; otherwise, the next instruction is fetched and executed.

If more than one interrupt is pending at the end of an instruction execution, the highest priority interrupt is serviced first. **Figure 7-11** demonstrates what happens when two interrupts are pending. If an interrupt is pending upon exit from the original interrupt service routine, the pending interrupt is serviced before the LDA instruction is executed.

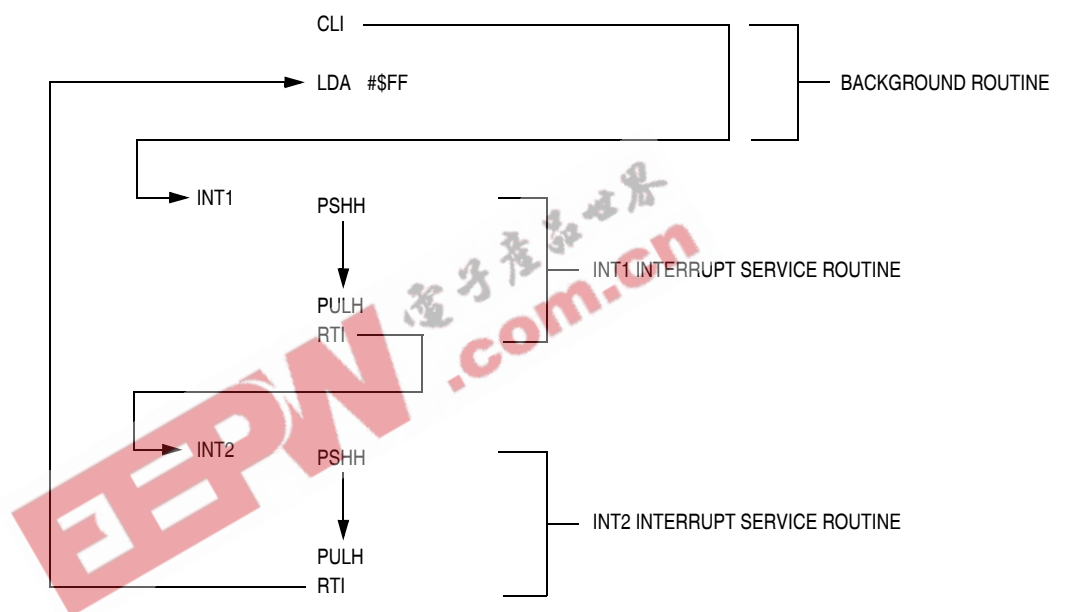

Figure 7-11. Interrupt Recognition Example

The LDA opcode is prefetched by both the INT1 and INT2 RTI instructions. However, in the case of the INT1 RTI prefetch, this is a redundant operation.

NOTE: *To maintain compatibility with the M6805 Family, the H register is not pushed on the stack during interrupt entry. If the interrupt service routine modifies the H register or uses the indexed addressing mode, software should save the H register and then restore it prior to exiting the routine.*

7.6.1.2 SWI Instruction

The SWI instruction is a non-maskable instruction that causes an interrupt regardless of the state of the interrupt mask (I bit) in the condition code register.

NOTE: A software interrupt pushes PC onto the stack. A software interrupt does **not** push PC – 1, as a hardware interrupt does.

7.6.2 Interrupt Status Registers

The flags in the interrupt status registers identify maskable interrupt sources. [Table 7-3](#) summarizes the interrupt sources and the interrupt status register flags that they set. The interrupt status registers can be useful for debugging.

Table 7-3. Interrupt Sources

Priority	Source	Flag	Mask ¹	INT Register Flag	Vector Address
Highest  Lowest	Reset	—	—	—	\$FFFE–\$FFFF
	SWI Instruction	—	—	—	\$FFFC–\$FFFD
	$\overline{\text{IRQ1}}$ Pin	IRQF1	IMASK1	IF1	\$FFFA–\$FFFB
	Timer Channel 0 Interrupt	CH0F	CH0IE	IF3	\$FFF6–\$FFF7
	Timer Channel 1 Interrupt	CH1F	CH1IE	IF4	\$FFF4–\$FFF5
	Timer Overflow Interrupt	TOF	TOIE	IF5	\$FFF2–\$FFF3
	Keyboard Interrupt	KEYF	IMASKK	IF14	\$FFE0–\$FFE1
	ADC Conversion Complete Interrupt	COCO	AIEN	IF15	\$FFDE–\$FFDF

Note:

1. The I bit in the condition code register is a global mask for all interrupts sources except the SWI instruction.

7.6.2.1 Interrupt Status Register 1

Address: \$FE04

	Bit 7	6	5	4	3	2	1	Bit 0
Read:	0	IF5	IF4	IF3	0	IF1	0	0
Write:	R	R	R	R	R	R	R	R
Reset:	0	0	0	0	0	0	0	0

R = Reserved

Figure 7-12. Interrupt Status Register 1 (INT1)

IF1, IF3 to IF5 — Interrupt Flags

These flags indicate the presence of interrupt requests from the sources shown in [Table 7-3](#).

1 = Interrupt request present

0 = No interrupt request present

Bit 0, 1, 3 and 7 — Always read 0

7.6.2.2 Interrupt Status Register 2

Address: \$FE05

	Bit 7	6	5	4	3	2	1	Bit 0
Read:	IF14	0	0	0	0	0	0	0
Write:	R	R	R	R	R	R	R	R
Reset:	0	0	0	0	0	0	0	0

R = Reserved

Figure 7-13. Interrupt Status Register 2 (INT2)

IF14 — Interrupt Flags

This flag indicates the presence of interrupt requests from the sources shown in [Table 7-3](#).

1 = Interrupt request present

0 = No interrupt request present

Bit 0 to 6 — Always read 0

7.6.2.3 Interrupt Status Register 3

Address: \$FE06

	Bit 7	6	5	4	3	2	1	Bit 0
Read:	0	0	0	0	0	0	0	IF15
Write:	R	R	R	R	R	R	R	R
Reset:	0	0	0	0	0	0	0	0

R = Reserved

Figure 7-14. Interrupt Status Register 3 (INT3)

IF15 — Interrupt Flags

These flags indicate the presence of interrupt requests from the sources shown in [Table 7-3](#).

1 = Interrupt request present

0 = No interrupt request present

Bit 1 to 7 — Always read 0

7.6.3 Reset

All reset sources always have equal and highest priority and cannot be arbitrated.

7.6.4 Break Interrupts

The break module can stop normal program flow at a software-programmable break point by asserting its break interrupt output. (See [Section 17. Break Module \(BREAK\)](#).) The SIM puts the CPU into the break state by forcing it to the SWI vector location. Refer to the break interrupt subsection of each module to see how each module is affected by the break state.

7.6.5 Status Flag Protection in Break Mode

The SIM controls whether status flags contained in other modules can be cleared during break mode. The user can select whether flags are

protected from being cleared by properly initializing the break clear flag enable bit (BCFE) in the break flag control register (BFGR).

Protecting flags in break mode ensures that set flags will not be cleared while in break mode. This protection allows registers to be freely read and written during break mode without losing status flag information.

Setting the BCFE bit enables the clearing mechanisms. Once cleared in break mode, a flag remains cleared even when break mode is exited. Status flags with a two-step clearing mechanism — for example, a read of one register followed by the read or write of another — are protected, even when the first step is accomplished prior to entering break mode. Upon leaving break mode, execution of the second step will clear the flag as normal.

7.7 Low-Power Modes

Executing the WAIT or STOP instruction puts the MCU in a low-power-consumption mode for standby situations. The SIM holds the CPU in a non-clocked state. The operation of each of these modes is described below. Both STOP and WAIT clear the interrupt mask (I) in the condition code register, allowing interrupts to occur.

7.7.1 Wait Mode

In wait mode, the CPU clocks are inactive while the peripheral clocks continue to run. [Figure 7-15](#) shows the timing for wait mode entry.

A module that is active during wait mode can wake up the CPU with an interrupt if the interrupt is enabled. Stacking for the interrupt begins one cycle after the WAIT instruction during which the interrupt occurred. In wait mode, the CPU clocks are inactive. Refer to the wait mode subsection of each module to see if the module is active or inactive in wait mode. Some modules can be programmed to be active in wait mode.

Wait mode can also be exited by a reset or break. A break interrupt during wait mode sets the SIM break stop/wait bit, SBSW, in the break

status register (BSR). If the COP disable bit, COPD, in the mask option register is logic zero, then the computer operating properly module (COP) is enabled and remains active in wait mode.

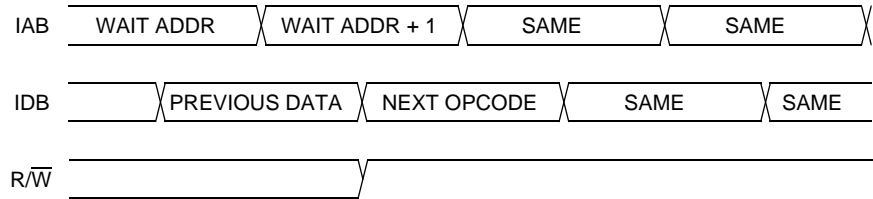

NOTE: Previous data can be operand data or the WAIT opcode, depending on the last instruction.

Figure 7-15. Wait Mode Entry Timing

Figure 7-16 and **Figure 7-17** show the timing for WAIT recovery.

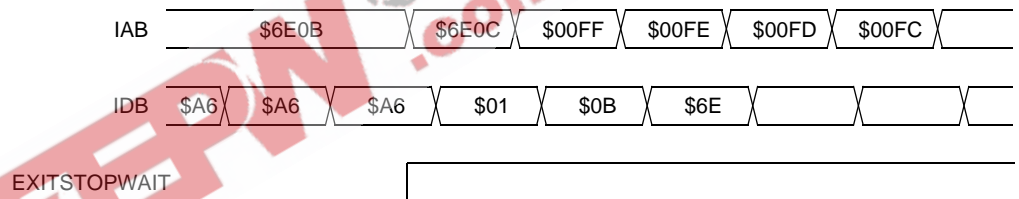

NOTE: EXITSTOPWAIT = $\overline{\text{RST}}$ pin OR CPU interrupt OR break interrupt

Figure 7-16. Wait Recovery from Interrupt or Break

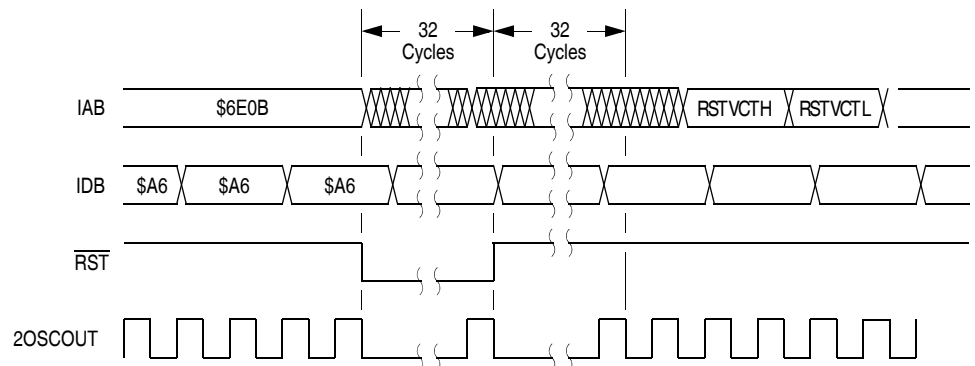

Figure 7-17. Wait Recovery from Internal Reset

7.7.2 Stop Mode

In stop mode, the SIM counter is reset and the system clocks are disabled. An interrupt request from a module can cause an exit from stop mode. Stacking for interrupts begins after the selected stop recovery time has elapsed. Reset or break also causes an exit from stop mode.

The SIM disables the oscillator signals (OSCOOUT and 2OSCOOUT) in stop mode, stopping the CPU and peripherals. Stop recovery time is selectable using the SSREC bit in the configuration register (CONFIG). If SSREC is set, stop recovery is reduced from the normal delay of 4096 2OSCOOUT cycles down to 32. This is ideal for applications using canned oscillators that do not require long start-up times from stop mode.

NOTE: External crystal applications should use the full stop recovery time by clearing the SSREC bit.

A break interrupt during stop mode sets the SIM break stop/wait bit (SBSW) in the break status register (BSR).

The SIM counter is held in reset from the execution of the STOP instruction until the beginning of stop recovery. It is then used to time the recovery period. Figure 7-18 shows stop mode entry timing.

NOTE: To minimize stop current, all pins configured as inputs should be driven to a logic 1 or logic 0.

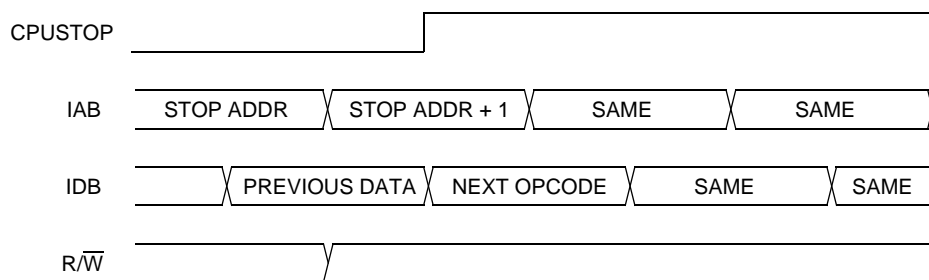

NOTE: Previous data can be operand data or the STOP opcode, depending on the last instruction.

Figure 7-18. Stop Mode Entry Timing

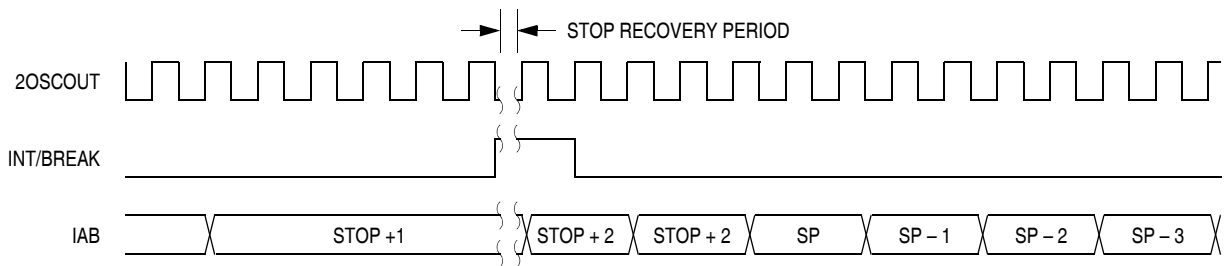

Figure 7-19. Stop Mode Recovery from Interrupt or Break

7.8 SIM Registers

The SIM has three memory mapped registers. [Table 7-4](#) shows the mapping of these registers.

Table 7-4. SIM Registers

Address	Register	Access Mode
\$FE00	BSR	User
\$FE01	RSR	User
\$FE03	BFCR	User

7.8.1 Break Status Register (BSR)

The break status register contains a flag to indicate that a break caused an exit from stop or wait mode.

Address: \$FE00

	Bit 7	6	5	4	3	2	1	Bit 0
Read:	R	R	R	R	R	R	SBSW	R
Write:	R	R	R	R	R	R	Note ⁽¹⁾	R

Reset: 0

R = Reserved

1. Writing a logic zero clears SBSW.

Figure 7-20. Break Status Register (BSR)

SBSW — SIM Break Stop/Wait

This status bit is useful in applications requiring a return to wait or stop mode after exiting from a break interrupt. Clear SBSW by writing a logic zero to it. Reset clears SBSW.

1 = Stop mode or wait mode was exited by break interrupt

0 = Stop mode or wait mode was not exited by break interrupt

SBSW can be read within the break state SWI routine. The user can modify the return address on the stack by subtracting one from it. The following code is an example of this. Writing zero to the SBSW bit clears it.

```
; This code works if the H register has been pushed onto the stack in the break
; service routine software. This code should be executed at the end of the
; break service routine software.

HIBYTE EQU 5
LOBYTE EQU 6

; If not SBSW, do RTI
BRCLR SBSW,BSR, RETURN ; See if wait mode or stop mode was exited
; by break.
TST LOBYTE,SP ; If RETURNLO is not zero,
BNE DOLO ; then just decrement low byte.
DEC HIBYTE,SP ; Else deal with high byte, too.
DOLO DEC LOBYTE,SP ; Point to WAIT/STOP opcode.
RETURN PULH ; Restore H register.
RTI
```

7.8.2 Reset Status Register (RSR)

This register contains six flags that show the source of the last reset. Clear the SIM reset status register by reading it. A power-on reset sets the POR bit and clears all other bits in the register.

Address: \$FE01

	Bit 7	6	5	4	3	2	1	Bit 0
Read:	POR	PIN	COP	ILOP	ILAD	MODRST	LVI	0
Write:								
POR:	1	0	0	0	0	0	0	0

 = Unimplemented

Figure 7-21. Reset Status Register (RSR)

POR — Power-On Reset Bit

- 1 = Last reset caused by POR circuit
- 0 = Read of SRSR

PIN — External Reset Bit

- 1 = Last reset caused by external reset pin (\overline{RST})
- 0 = POR or read of SRSR

COP — Computer Operating Properly Reset Bit

- 1 = Last reset caused by COP counter
- 0 = POR or read of SRSR

ILOP — Illegal Opcode Reset Bit

- 1 = Last reset caused by an illegal opcode
- 0 = POR or read of SRSR

ILAD — Illegal Address Reset Bit (opcode fetches only)

- 1 = Last reset caused by an opcode fetch from an illegal address
- 0 = POR or read of SRSR

MODRST — Monitor Mode Entry Module Reset bit

- 1 = Last reset caused by monitor mode entry when vector locations \$FFFE and \$FFFF are \$00 after POR while $IRQB = V_{DD}$
- 0 = POR or read of SRSR

LVI — Low Voltage Inhibit Reset bit

- 1 = Last reset caused by LVI circuit
- 0 = POR or read of SRSR

7.8.3 Break Flag Control Register (BFCR)

The break control register contains a bit that enables software to clear status bits while the MCU is in a break state.

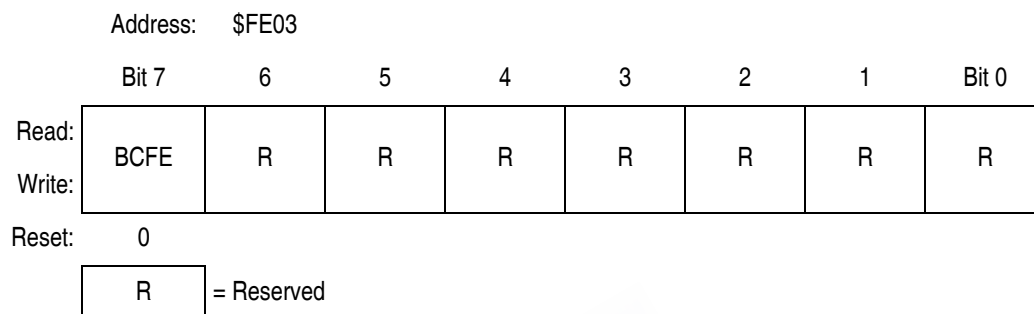

Figure 7-22. Break Flag Control Register (BFCR)

BCFE — Break Clear Flag Enable Bit

This read/write bit enables software to clear status bits by accessing status registers while the MCU is in a break state. To clear status bits during the break state, the BCFE bit must be set.

1 = Status bits clearable during break

0 = Status bits not clearable during break

Section 8. Oscillator (OSC)

8.1 Contents

8.2	Introduction	89
8.3	X-tal Oscillator (MC68HC08xxx)	90
8.4	RC Oscillator (MC68HRC08xxx)	91
8.5	I/O Signals	92
8.5.1	Crystal Amplifier Input Pin (OSC1)	92
8.5.2	Crystal Amplifier Output Pin (OSC2/PTA6/RCCLK)	92
8.5.3	Oscillator Enable Signal (SIMOSCEN)	92
8.5.4	X-tal Oscillator Clock (XTALCLK)	92
8.5.5	RC Oscillator Clock (RCCLK)	93
8.5.6	Oscillator Out 2 (2OSCOUT)	93
8.5.7	Oscillator Out (OSCOUT)	93
8.6	Low Power Modes	93
8.6.1	Wait Mode	93
8.6.2	Stop Mode	93
8.7	Oscillator During Break Mode	94

8.2 Introduction

The oscillator module provides the reference clock for the MCU system and bus. Two types of oscillator modules are available:

- MC68HC08xxx— built-in oscillator module (X-tal oscillator) that requires an external crystal or ceramic-resonator. This option also allows an external clock that can be driven directly into OSC1.
- MC68HRC08xxx — built-in oscillator module (RC oscillator) that requires an external RC connection only.

8.3 X-tal Oscillator (MC68HC08xxx)

The X-tal oscillator circuit is designed for use with an external crystal or ceramic resonator to provide accurate clock source.

In its typical configuration, the X-tal oscillator is connected in a Pierce oscillator configuration, as shown in **Figure 8-1**. This figure shows only the logical representation of the internal components and may not represent actual circuitry. The oscillator configuration uses five components:

- Crystal, X_1
- Fixed capacitor, C_1
- Tuning capacitor, C_2 (can also be a fixed capacitor)
- Feedback resistor, R_B
- Series resistor, R_S (optional)

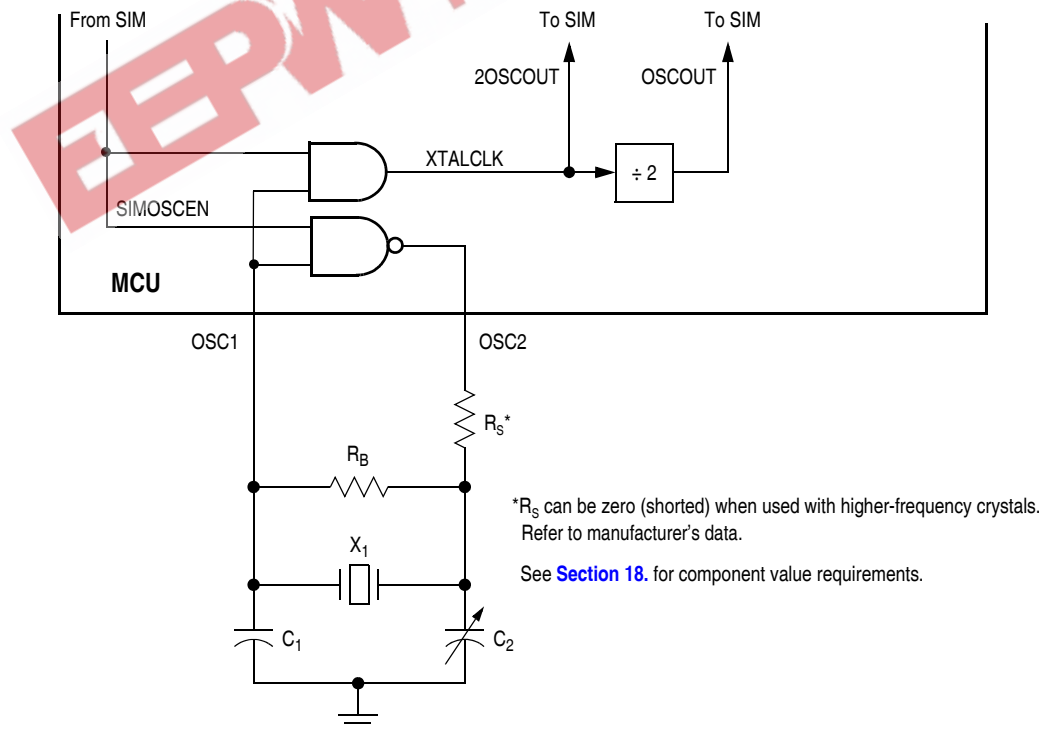

Figure 8-1. X-tal Oscillator External Connections

The series resistor (R_S) is included in the diagram to follow strict Pierce oscillator guidelines and may not be required for all ranges of operation, especially with high frequency crystals. Refer to the crystal manufacturer's data for more information.

8.4 RC Oscillator (MC68HRC08xxx)

The RC oscillator circuit is designed for use with external R and C to provide a clock source with tolerance less than 10%.

In its typical configuration, the RC oscillator requires two external components, one R and one C. Component values should have a tolerance of 1% or less, to obtain a clock source with less than 10% tolerance. The oscillator configuration uses two components:

- C_{EXT}
- R_{EXT}

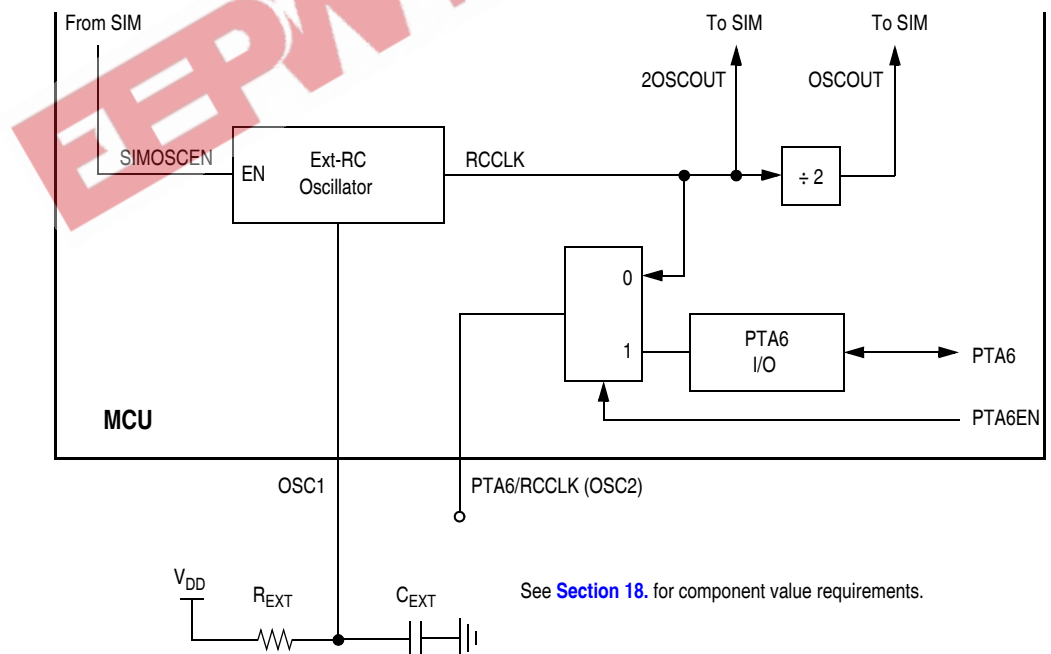

Figure 8-2. RC Oscillator External Connections

8.5 I/O Signals

The following paragraphs describe the oscillator I/O signals.

8.5.1 Crystal Amplifier Input Pin (OSC1)

OSC1 pin is an input to the crystal oscillator amplifier or the input to the RC oscillator circuit.

8.5.2 Crystal Amplifier Output Pin (OSC2/PTA6/RCCLK)

For the X-tal oscillator device, OSC2 pin is the output of the crystal oscillator inverting amplifier.

For the RC oscillator device, OSC2 pin can be configured as a general purpose I/O pin PTA6, or the output of the internal RC oscillator clock, RCCLK.

Option	OSC2 pin function
X-tal oscillator	Inverting OSC1
RC oscillator	Controlled by PTAEN bit in PTAPUER (\$0D) PTA6EN = 0: RCCLK output PTA6EN = 1: PTA6 I/O

8.5.3 Oscillator Enable Signal (SIMOSCEN)

The SIMOSCEN signal comes from the system integration module (SIM) and enables/disables the X-tal oscillator circuit or the RC-oscillator.

8.5.4 X-tal Oscillator Clock (XTALCLK)

XTALCLK is the X-tal oscillator output signal. It runs at the full speed of the crystal (f_{XCLK}) and comes directly from the crystal oscillator circuit.

Figure 8-1 shows only the logical relation of XTALCLK to OSC1 and OSC2 and may not represent the actual circuitry. The duty cycle of XTALCLK is unknown and may depend on the crystal and other external factors. Also, the frequency and amplitude of XTALCLK can be unstable at start-up.

8.5.5 RC Oscillator Clock (RCCLK)

RCCLK is the RC oscillator output signal. Its frequency is directly proportional to the time constant of the external R and C. [Figure 8-2](#) shows only the logical relation of RCCLK to OSC1 and may not represent the actual circuitry.

8.5.6 Oscillator Out 2 (2OSCOUT)

2OSCOUT is same as the input clock (XTALCLK or RCCLK). This signal is driven to the SIM module and is used to determine the COP cycles.

8.5.7 Oscillator Out (OSCOUT)

The frequency of this signal is equal to half of the 2OSCOUT, this signal is driven to the SIM for generation of the bus clocks used by the CPU and other modules on the MCU. OSCOUT will be divided again in the SIM and results in the internal bus frequency being one fourth of the XTALCLK or RCCLK frequency.

8.6 Low Power Modes

The WAIT and STOP instructions put the MCU in low-power consumption standby modes.

8.6.1 Wait Mode

The WAIT instruction has no effect on the oscillator logic. OSCOUT and 2OSCOUT continues to drive to the SIM module.

8.6.2 Stop Mode

The STOP instruction disables the XTALCLK or the RCCLK output, hence OSCOUT and 2OSCOUT.

8.7 Oscillator During Break Mode

The oscillator continues to drive OSCOUT and 2OSCOUT when the device enters the break state.

EEPW 电子產品世界
.com.cn

Section 9. Monitor ROM (MON)

9.1 Contents

9.2	Introduction	95
9.3	Features	96
9.4	Functional Description	96
9.4.1	Entering Monitor Mode	98
9.4.2	Baud Rate	100
9.4.3	Data Format	100
9.4.4	Echoing	100
9.4.5	Break Signal	101
9.4.6	Commands	101

9.2 Introduction

This section describes the monitor ROM (MON). The monitor ROM allows complete testing of the MCU through a single-wire interface with a host computer.

9.3 Features

Features of the monitor ROM include the following:

- Normal user-mode pin functionality
- One pin dedicated to serial communication between monitor ROM and host computer
- Standard mark/space non-return-to-zero (NRZ) communication with host computer
- 4800 Baud to 28.8 k-Baud communication with host computer
- Execution of code in RAM or ROM

9.4 Functional Description

The monitor ROM receives and executes commands from a host computer. [Figure 9-1](#) shows an example circuit used to enter monitor mode and communicate with a host computer via a standard RS-232 interface.

While simple monitor commands can access any memory address, the MCU has a ROM security feature that requires proper procedures to be followed before the ROM can be accessed. Access to the ROM is denied to unauthorized users of customer-specified software.

In monitor mode, the MCU can execute host-computer code in RAM while all MCU pins except PTB0 retain normal operating mode functions. All communication between the host computer and the MCU is through the PTB0 pin. A level-shifting and multiplexing interface is required between PTB0 and the host computer. PTB0 is used in a wired-OR configuration and requires a pull-up resistor.

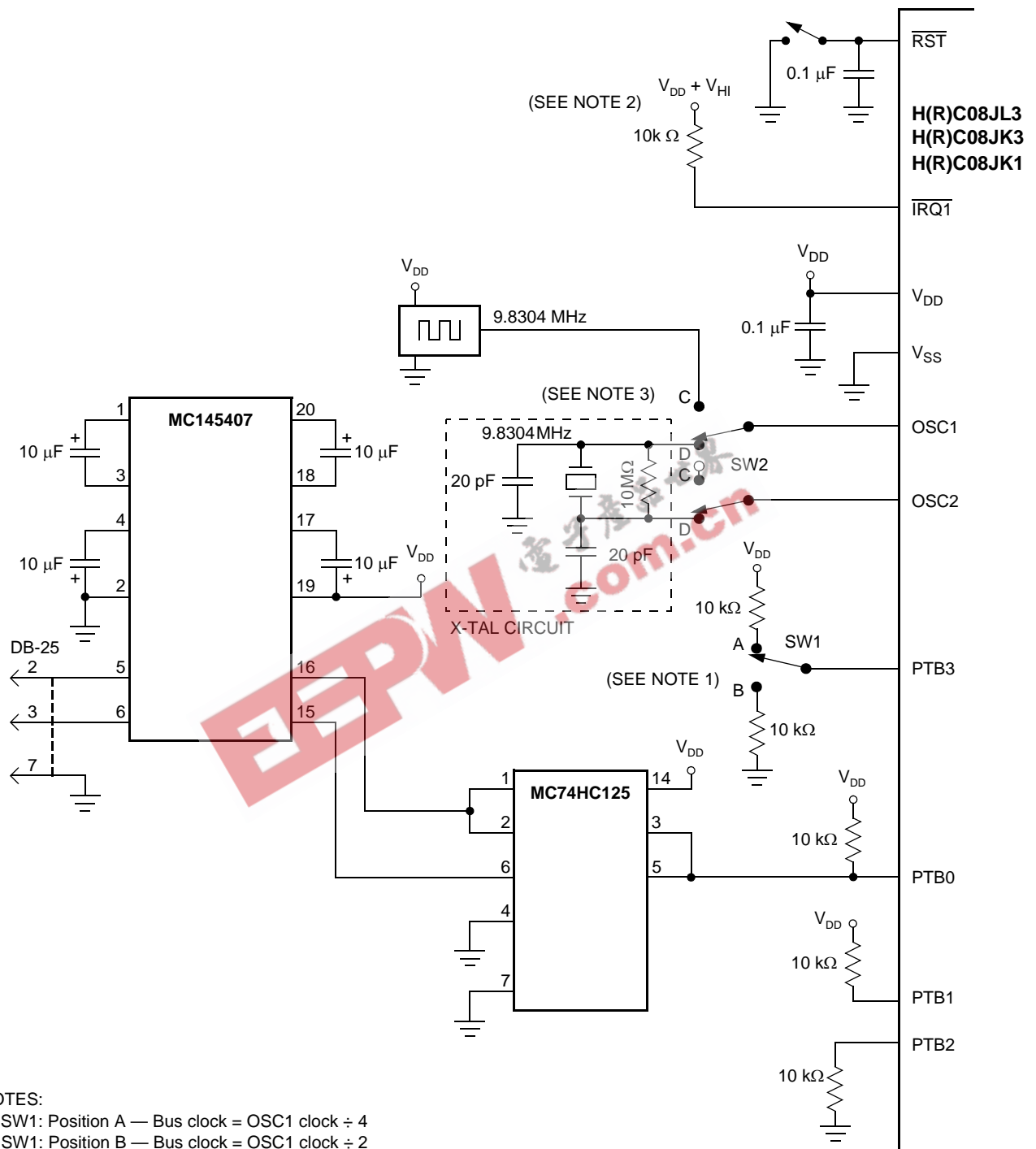

NOTES:

- SW1: Position A — Bus clock = OSC1 clock \div 4
SW1: Position B — Bus clock = OSC1 clock \div 2
- See [Table 18-4](#) for $\overline{\text{IRQ1}}$ voltage level requirements.
- SW2: Position C — External oscillator clock input
SW2: Position D — Crystal oscillator clock input
External oscillator must have a 50% duty cycle

Figure 9-1. Monitor Mode Circuit

9.4.1 Entering Monitor Mode

Table 9-1 shows the pin conditions for entering monitor mode. As specified in the table, monitor mode may be entered after a POR and will allow communication at 9600 baud provided one of the following sets of conditions is met:

1. If $\overline{\text{IRQ1}} = V_{\text{DD}} + V_{\text{HI}}$:
 - OSC1 is 4.9125MHz
 - PTB3 = low
2. If $\overline{\text{IRQ1}} = V_{\text{DD}} + V_{\text{HI}}$:
 - OSC1 is 9.8304MHz
 - PTB3 = high

Table 9-1. Monitor Mode Entry Requirements and Options

$\overline{\text{IRQ1}}$	PTB3	PTB2	PTB1	PTB0	Clock Source and Frequency	Bus Frequency	Comments
$V_{\text{DD}} + V_{\text{HI}}$	0	0	1	1	OSC1 at 4.9152MHz	2.4576MHz	Bypasses RC oscillator (in HRC08xxx); OSC1 input must be x-tal oscillator or external oscillator clock. 9600 baud communication on PTB0. COP disabled.
$V_{\text{DD}} + V_{\text{HI}}$	1	0	1	1	OSC1 at 9.8304MHz	2.4576MHz	
V_{DD}	X	X	X	X	X-tal or RC oscillator at desired frequency	XTALCLK ÷ 4 or RCCLK ÷ 4	Enters User mode
Notes: 1. PTB3 = 0: Bypasses the divide-by-two prescaler to SIM. The OSC1 clock must be 50% duty cycle for this condition. 2. XTALCLK is the X-tal oscillator output, for MC68HC08xxx. See Figure 8-1 . 4. RCCLK is the RC oscillator output, for MC68HRC08xxx. See Figure 8-2 . 5. See Table 18-4 for $V_{\text{DD}} + V_{\text{HI}}$ voltage level requirements.							

If $V_{\text{DD}} + V_{\text{HI}}$ is applied to $\overline{\text{IRQ1}}$ and PTB3 is low upon monitor mode entry (**Table 9-1** condition set 1), the bus frequency is a divide-by-two of the clock input to OSC1. If PTB3 is high with $V_{\text{DD}} + V_{\text{HI}}$ applied to $\overline{\text{IRQ1}}$ upon monitor mode entry (**Table 9-1** condition set 2), the bus frequency is a divide-by-four of the clock input to OSC1. Holding the PTB3 pin low when entering monitor mode causes a bypass of a divide-by-two stage at the internal clock circuit. In this event, the OSCOUT frequency is equal

to the 2OSCOU frequency, and OSC1 input directly generates internal bus clocks. In this case, the OSC1 signal must have a 50% duty cycle at maximum bus frequency.

In monitor mode, the COP is disabled as long as $V_{DD} + V_{HI}$ is applied to either the $\overline{IRQ1}$ or the \overline{RST} pin. (See [Section 7. System Integration Module \(SIM\)](#) for more information on modes of operation.)

Enter monitor mode with the pin configuration shown above by pulling \overline{RST} low and then high. The rising edge of \overline{RST} latches monitor mode. Once monitor mode is latched, the values on the specified pins can change.

Once out of reset, the MCU sends a break signal (10 consecutive logic zeros) to the host computer, indicating that it is ready to receive a command. The break signal also provides a timing reference to allow the host to determine the necessary baud rate.

In monitor mode, the MCU uses different vectors for reset, SWI, and break interrupt. The alternate vectors are in the \$FE page instead of the \$FF page and allow code execution from the internal monitor firmware instead of user code.

Table 9-2 is a summary of the vector differences between user mode and monitor mode.

Table 9-2. Monitor Mode Vector Differences

Modes	Functions						
	COP	Reset Vector High	Reset Vector Low	Break Vector High	Break Vector Low	SWI Vector High	SWI Vector Low
User	Enabled	\$FFFE	\$FFFF	\$FFFC	\$FFFD	\$FFFC	\$FFFD
Monitor	Disabled ⁽¹⁾	\$FEFE	\$FEFF	\$FEFC	\$FEFD	\$FEFC	\$FEFD
Notes: 1. If the high voltage ($V_{DD} + V_{HI}$) is removed from the $\overline{IRQ1}$ pin or the \overline{RST} pin, the SIM asserts its COP enable output. The COP is a mask option enabled or disabled by the COPD bit in the configuration register.							

When the host computer has completed downloading code into the MCU RAM, the host then sends a RUN command, which executes an RTI, which sends control to the address on the stack pointer.

9.4.2 Baud Rate

The communication baud rate is dependant on oscillator frequency and the state of PTB3 upon monitor mode entry. When PTB3 is high, the divide by ratio is 1024. If the PTB3 pin is at logic zero upon entry into monitor mode, the divide by ratio is 512.

Table 9-3. Monitor Baud Rate Selection

Oscillator Input Frequency	PTB3	Baud Rate
4.9152 MHz	0	9600 bps
9.8304 MHz	1	9600 bps
4.9152 MHz	1	4800 bps

9.4.3 Data Format

Communication with the monitor ROM is in standard non-return-to-zero (NRZ) mark/space data format. (See [Figure 9-2](#) and [Figure 9-3](#).)

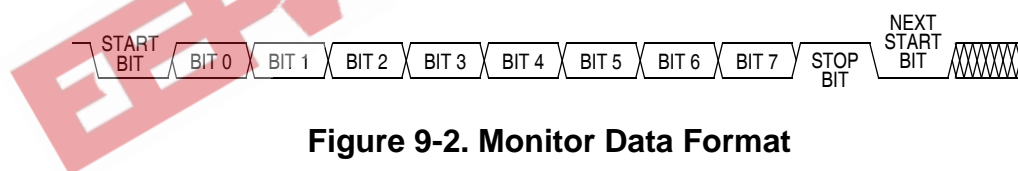

Figure 9-2. Monitor Data Format

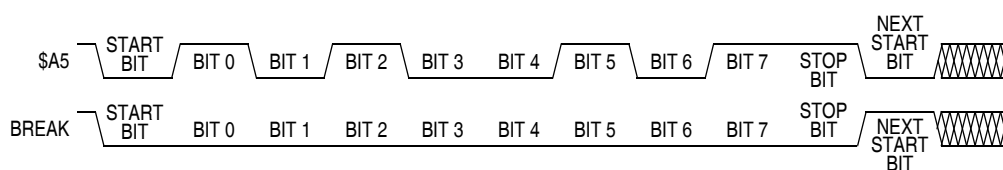

Figure 9-3. Sample Monitor Waveforms

The data transmit and receive rate can be anywhere from 4800 baud to 28.8k-baud. Transmit and receive baud rates must be identical.

9.4.4 Echoing

As shown in [Figure 9-4](#), the monitor ROM immediately echoes each received byte back to the PTB0 pin for error checking.

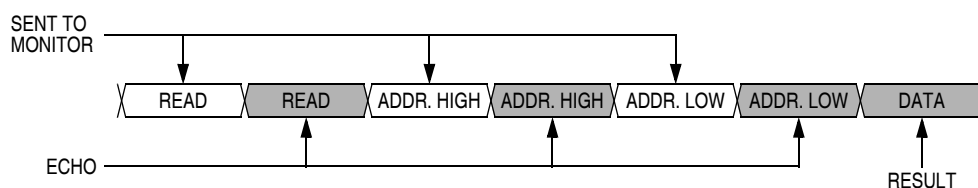

Figure 9-4. Read Transaction

Any result of a command appears after the echo of the last byte of the command.

9.4.5 Break Signal

A start bit followed by nine low bits is a break signal. (See [Figure 9-5.](#)) When the monitor receives a break signal, it drives the PTB0 pin high for the duration of two bits before echoing the break signal.

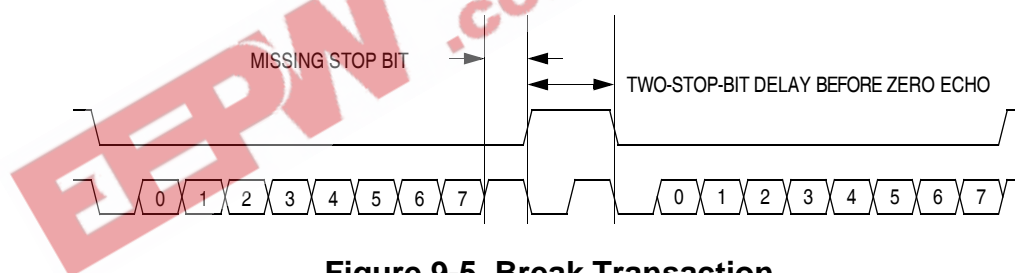

Figure 9-5. Break Transaction

9.4.6 Commands

The monitor ROM uses the following commands:

- READ (read memory)
- WRITE (write memory)
- IREAD (indexed read)
- IWRITE (indexed write)
- READSP (read stack pointer)
- RUN (run user program)

Table 9-4. READ (Read Memory) Command

Description	Read byte from memory
Operand	Specifies 2-byte address in high byte:low byte order
Data Returned	Returns contents of specified address
Opcode	\$4A
<p>Command Sequence</p>	

Table 9-5. WRITE (Write Memory) Command

Description	Write byte to memory
Operand	Specifies 2-byte address in high byte:low byte order; low byte followed by data byte
Data Returned	None
Opcode	\$49
<p>Command Sequence</p>	

Table 9-6. IREAD (Indexed Read) Command

Description	Read next 2 bytes in memory from last address accessed
Operand	Specifies 2-byte address in high byte:low byte order
Data Returned	Returns contents of next two addresses
Opcode	\$1A
<p>Command Sequence</p>	

Table 9-7. IWRITE (Indexed Write) Command

Description	Write to last address accessed + 1
Operand	Specifies single data byte
Data Returned	None
Opcode	\$19
<p>Command Sequence</p>	

NOTE: A sequence of IREAD or IWRITE commands can sequentially access a block of memory over the full 64-Kbyte memory map.

Table 9-8. READSP (Read Stack Pointer) Command

Description	Reads stack pointer
Operand	None
Data Returned	Returns stack pointer in high byte:low byte order
Opcode	\$0C
<p>Command Sequence</p>	

Table 9-9. RUN (Run User Program) Command

Description	Executes RTI instruction
Operand	None
Data Returned	None
Opcode	\$28
<p>Command Sequence</p>	

Section 10. Timer Interface Module (TIM)

10.1 Contents

10.2	Introduction	106
10.3	Features	106
10.4	Pin Name Conventions	106
10.5	Functional Description	107
10.5.1	TIM Counter Prescaler	109
10.5.2	Input Capture	109
10.5.3	Output Compare	109
10.5.3.1	Unbuffered Output Compare	110
10.5.3.2	Buffered Output Compare	110
10.5.4	Pulse Width Modulation (PWM)	111
10.5.4.1	Unbuffered PWM Signal Generation	112
10.5.4.2	Buffered PWM Signal Generation	113
10.5.4.3	PWM Initialization	114
10.6	Interrupts	115
10.7	Wait Mode	115
10.8	TIM During Break Interrupts	116
10.9	I/O Signals	116
10.10	I/O Registers	117
10.10.1	TIM Status and Control Register (TSC)	117
10.10.2	TIM Counter Registers (TCNTH:TCNTL)	119
10.10.3	TIM Counter Modulo Registers (TMODH:TMODL)	120
10.10.4	TIM Channel Status and Control Registers (TSC0:TSC1)	121
10.10.5	TIM Channel Registers (TCH0H/L:TCH1H/L)	125

10.2 Introduction

This section describes the timer interface module (TIM2, Version B). The TIM is a two-channel timer that provides a timing reference with input capture, output compare, and pulse-width-modulation functions.

Figure 10-1 is a block diagram of the TIM.

10.3 Features

Features of the TIM include the following:

- Two input capture/output compare channels
 - Rising-edge, falling-edge, or any-edge input capture trigger
 - Set, clear, or toggle output compare action
- Buffered and unbuffered pulse width modulation (PWM) signal generation
- Programmable TIM clock input with 7-frequency internal bus clock prescaler selection
- Free-running or modulo up-count operation
- Toggle any channel pin on overflow
- TIM counter stop and reset bits
- Modular architecture expandable to eight channels

10.4 Pin Name Conventions

The TIM share two I/O pins with two port D I/O pins. The full name of the TIM I/O pins are listed in **Table 10-1**. The generic pin name appear in the text that follows.

Table 10-1. Pin Name Conventions

TIM Generic Pin Names:	TCH0	TCH1
Full TIM Pin Names:	PTD4/TCH0	PTD5/TCH1

10.5 Functional Description

Figure 10-1 shows the structure of the TIM. The central component of the TIM is the 16-bit TIM counter that can operate as a free-running counter or a modulo up-counter. The TIM counter provides the timing reference for the input capture and output compare functions. The TIM counter modulo registers, TMODH:TMODL, control the modulo value of the TIM counter. Software can read the TIM counter value at any time without affecting the counting sequence.

The two TIM channels are programmable independently as input capture or output compare channels.

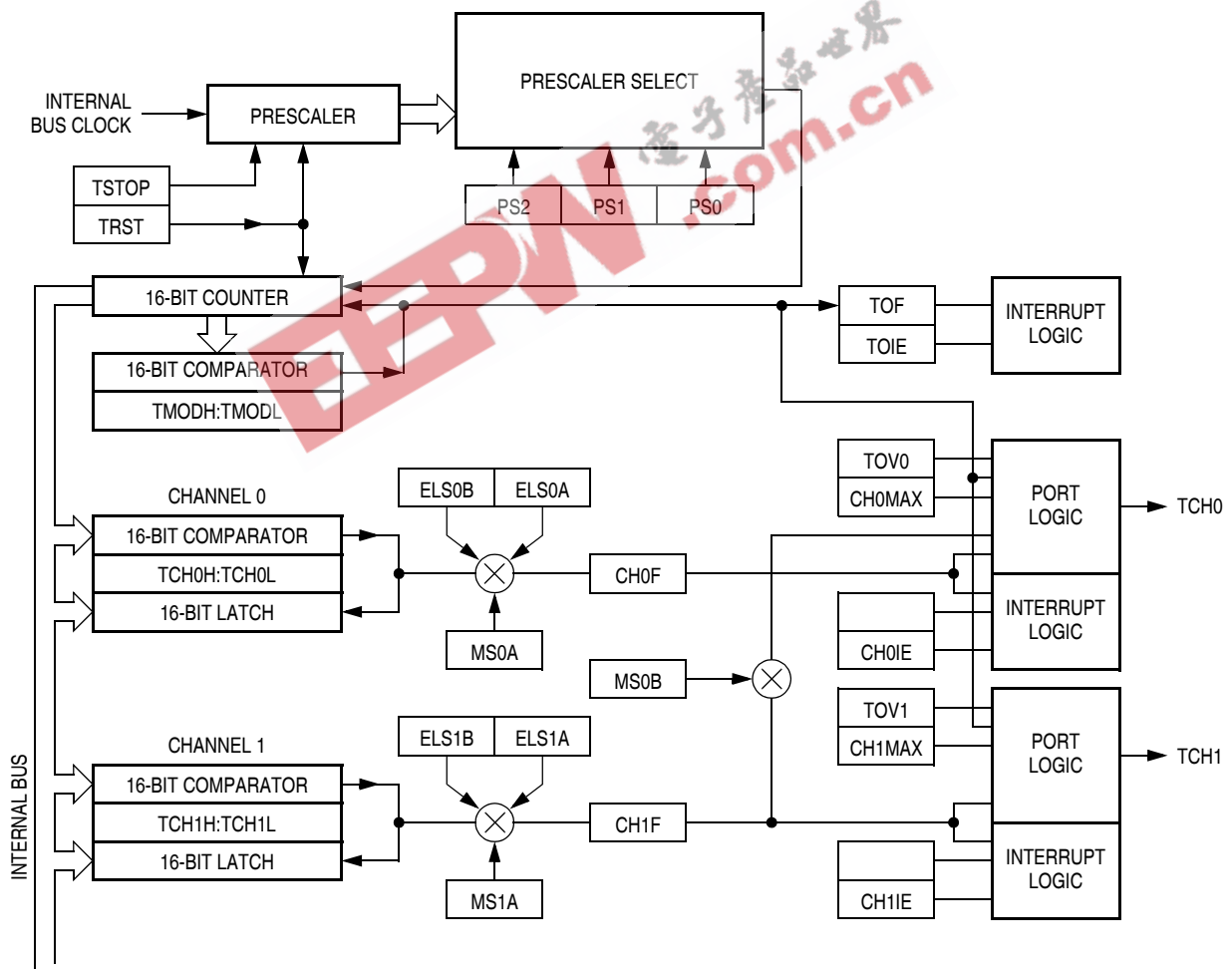

Figure 10-1. TIM Block Diagram

Addr.	Register Name	Bit 7	6	5	4	3	2	1	Bit 0	
\$0020	TIM Status and Control Register (TSC)	Read:	TOF	TOIE	TSTOP	0	0	PS2	PS1	PS0
		Write:	0			TRST				
		Reset:	0	0	1	0	0	0	0	0
\$0021	TIM Counter Register High (TCNTH)	Read:	Bit15	Bit14	Bit13	Bit12	Bit11	Bit10	Bit9	Bit8
		Write:								
		Reset:	0	0	0	0	0	0	0	0
\$0022	TIM Counter Register Low (TCNTL)	Read:	Bit7	Bit6	Bit5	Bit4	Bit3	Bit2	Bit1	Bit0
		Write:								
		Reset:	0	0	0	0	0	0	0	0
\$0023	TIM Counter Modulo Register High (TMODH)	Read:	Bit15	Bit14	Bit13	Bit12	Bit11	Bit10	Bit9	Bit8
		Write:								
		Reset:	1	1	1	1	1	1	1	1
\$0024	TIM Counter Modulo Register Low (TMODL)	Read:	Bit7	Bit6	Bit5	Bit4	Bit3	Bit2	Bit1	Bit0
		Write:								
		Reset:	1	1	1	1	1	1	1	1
\$0025	TIM Channel 0 Status and Control Register (TSC0)	Read:	CH0F	CH0IE	MS0B	MS0A	ELS0B	ELS0A	TOV0	CH0MAX
		Write:	0							
		Reset:	0	0	0	0	0	0	0	0
\$0026	TIM Channel 0 Register High (TCH0H)	Read:	Bit15	Bit14	Bit13	Bit12	Bit11	Bit10	Bit9	Bit8
		Write:								
		Reset:	Indeterminate after reset							
\$0027	TIM Channel 0 Register Low (TCH0L)	Read:	Bit7	Bit6	Bit5	Bit4	Bit3	Bit2	Bit1	Bit0
		Write:								
		Reset:	Indeterminate after reset							
\$0028	TIM Channel 1 Status and Control Register (TSC1)	Read:	CH1F	CH1IE	0	MS1A	ELS1B	ELS1A	TOV1	CH1MAX
		Write:	0							
		Reset:	0	0	0	0	0	0	0	0

Figure 10-2. TIM I/O Register Summary

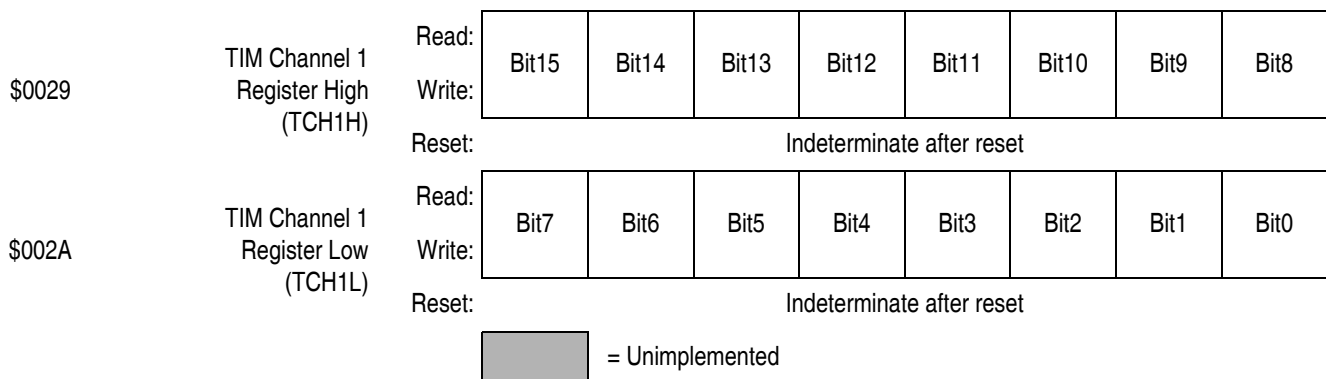

Figure 10-2. TIM I/O Register Summary

10.5.1 TIM Counter Prescaler

The TIM clock source is one of the seven prescaler outputs. The prescaler generates seven clock rates from the internal bus clock. The prescaler select bits, PS[2:0], in the TIM status and control register (TSC) select the TIM clock source.

10.5.2 Input Capture

With the input capture function, the TIM can capture the time at which an external event occurs. When an active edge occurs on the pin of an input capture channel, the TIM latches the contents of the TIM counter into the TIM channel registers, TCHxH:TCHxL. The polarity of the active edge is programmable. Input captures can generate TIM CPU interrupt requests.

10.5.3 Output Compare

With the output compare function, the TIM can generate a periodic pulse with a programmable polarity, duration, and frequency. When the counter reaches the value in the registers of an output compare channel, the TIM can set, clear, or toggle the channel pin. Output compares can generate TIM CPU interrupt requests.

10.5.3.1 Unbuffered Output Compare

Any output compare channel can generate unbuffered output compare pulses as described in [10.5.3 Output Compare](#). The pulses are unbuffered because changing the output compare value requires writing the new value over the old value currently in the TIM channel registers.

An unsynchronized write to the TIM channel registers to change an output compare value could cause incorrect operation for up to two counter overflow periods. For example, writing a new value before the counter reaches the old value but after the counter reaches the new value prevents any compare during that counter overflow period. Also, using a TIM overflow interrupt routine to write a new, smaller output compare value may cause the compare to be missed. The TIM may pass the new value before it is written.

Use the following methods to synchronize unbuffered changes in the output compare value on channel x:

- When changing to a smaller value, enable channel x output compare interrupts and write the new value in the output compare interrupt routine. The output compare interrupt occurs at the end of the current output compare pulse. The interrupt routine has until the end of the counter overflow period to write the new value.
- When changing to a larger output compare value, enable channel x TIM overflow interrupts and write the new value in the TIM overflow interrupt routine. The TIM overflow interrupt occurs at the end of the current counter overflow period. Writing a larger value in an output compare interrupt routine (at the end of the current pulse) could cause two output compares to occur in the same counter overflow period.

10.5.3.2 Buffered Output Compare

Channels 0 and 1 can be linked to form a buffered output compare channel whose output appears on the TCH0 pin. The TIM channel registers of the linked pair alternately control the output.

Setting the MS0B bit in TIM channel 0 status and control register (TSC0) links channel 0 and channel 1. The output compare value in the TIM

channel 0 registers initially controls the output on the TCH0 pin. Writing to the TIM channel 1 registers enables the TIM channel 1 registers to synchronously control the output after the TIM overflows. At each subsequent overflow, the TIM channel registers (0 or 1) that control the output are the ones written to last. TSC0 controls and monitors the buffered output compare function, and TIM channel 1 status and control register (TSC1) is unused. While the MS0B bit is set, the channel 1 pin, TCH1, is available as a general-purpose I/O pin.

NOTE: *In buffered output compare operation, do not write new output compare values to the currently active channel registers. Writing to the active channel registers is the same as generating unbuffered output compares.*

10.5.4 Pulse Width Modulation (PWM)

By using the toggle-on-overflow feature with an output compare channel, the TIM can generate a PWM signal. The value in the TIM counter modulo registers determines the period of the PWM signal. The channel pin toggles when the counter reaches the value in the TIM counter modulo registers. The time between overflows is the period of the PWM signal.

As [Figure 10-3](#) shows, the output compare value in the TIM channel registers determines the pulse width of the PWM signal. The time between overflow and output compare is the pulse width. Program the TIM to clear the channel pin on output compare if the state of the PWM pulse is logic one. Program the TIM to set the pin if the state of the PWM pulse is logic zero.

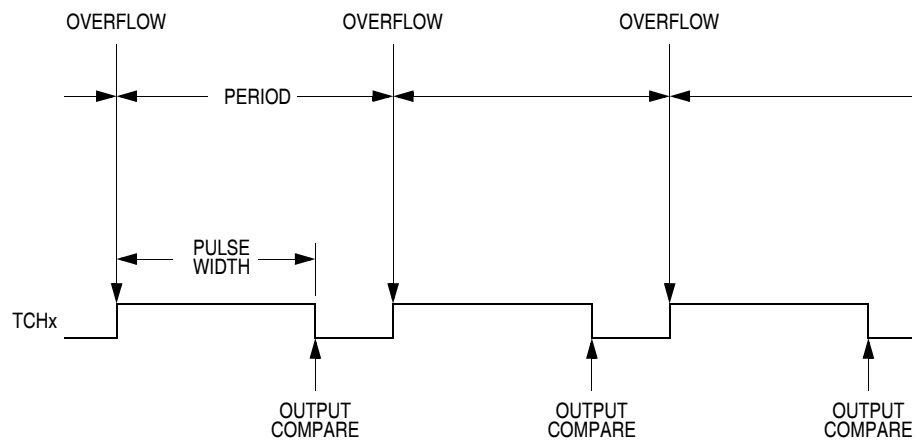

Figure 10-3. PWM Period and Pulse Width

The value in the TIM counter modulo registers and the selected prescaler output determines the frequency of the PWM output. The frequency of an 8-bit PWM signal is variable in 256 increments. Writing \$00FF (255) to the TIM counter modulo registers produces a PWM period of 256 times the internal bus clock period if the prescaler select value is 000 (see [10.10.1 TIM Status and Control Register \(TSC\)](#)).

The value in the TIM channel registers determines the pulse width of the PWM output. The pulse width of an 8-bit PWM signal is variable in 256 increments. Writing \$0080 (128) to the TIM channel registers produces a duty cycle of 128/256 or 50%.

10.5.4.1 Unbuffered PWM Signal Generation

Any output compare channel can generate unbuffered PWM pulses as described in [10.5.4 Pulse Width Modulation \(PWM\)](#). The pulses are unbuffered because changing the pulse width requires writing the new pulse width value over the old value currently in the TIM channel registers.

An unsynchronized write to the TIM channel registers to change a pulse width value could cause incorrect operation for up to two PWM periods. For example, writing a new value before the counter reaches the old value but after the counter reaches the new value prevents any compare during that PWM period. Also, using a TIM overflow interrupt routine to

write a new, smaller pulse width value may cause the compare to be missed. The TIM may pass the new value before it is written.

Use the following methods to synchronize unbuffered changes in the PWM pulse width on channel x:

- When changing to a shorter pulse width, enable channel x output compare interrupts and write the new value in the output compare interrupt routine. The output compare interrupt occurs at the end of the current pulse. The interrupt routine has until the end of the PWM period to write the new value.
- When changing to a longer pulse width, enable channel x TIM overflow interrupts and write the new value in the TIM overflow interrupt routine. The TIM overflow interrupt occurs at the end of the current PWM period. Writing a larger value in an output compare interrupt routine (at the end of the current pulse) could cause two output compares to occur in the same PWM period.

NOTE: *In PWM signal generation, do not program the PWM channel to toggle on output compare. Toggling on output compare prevents reliable 0% duty cycle generation and removes the ability of the channel to self-correct in the event of software error or noise. Toggling on output compare also can cause incorrect PWM signal generation when changing the PWM pulse width to a new, much larger value.*

10.5.4.2 Buffered PWM Signal Generation

Channels 0 and 1 can be linked to form a buffered PWM channel whose output appears on the TCH0 pin. The TIM channel registers of the linked pair alternately control the pulse width of the output.

Setting the MS0B bit in TIM channel 0 status and control register (TSC0) links channel 0 and channel 1. The TIM channel 0 registers initially control the pulse width on the TCH0 pin. Writing to the TIM channel 1 registers enables the TIM channel 1 registers to synchronously control the pulse width at the beginning of the next PWM period. At each subsequent overflow, the TIM channel registers (0 or 1) that control the pulse width are the ones written to last. TSC0 controls and monitors the buffered PWM function, and TIM channel 1 status and control register

(TSC1) is unused. While the MS0B bit is set, the channel 1 pin, TCH1, is available as a general-purpose I/O pin.

NOTE: *In buffered PWM signal generation, do not write new pulse width values to the currently active channel registers. Writing to the active channel registers is the same as generating unbuffered PWM signals.*

10.5.4.3 PWM Initialization

To ensure correct operation when generating unbuffered or buffered PWM signals, use the following initialization procedure:

1. In the TIM status and control register (TSC):
 - a. Stop the TIM counter by setting the TIM stop bit, TSTOP.
 - b. Reset the TIM counter by setting the TIM reset bit, TRST.
2. In the TIM counter modulo registers (TMODH:TMODL), write the value for the required PWM period.
3. In the TIM channel x registers (TCHxH:TCHxL), write the value for the required pulse width.
4. In TIM channel x status and control register (TSCx):
 - a. Write 0:1 (for unbuffered output compare or PWM signals) or 1:0 (for buffered output compare or PWM signals) to the mode select bits, MSxB:MSxA. (See [Table 10-3](#).)
 - b. Write 1 to the toggle-on-overflow bit, TOVx.
 - c. Write 1:0 (to clear output on compare) or 1:1 (to set output on compare) to the edge/level select bits, ELSxB:ELSxA. The output action on compare must force the output to the complement of the pulse width level. (See [Table 10-3](#).)

NOTE: *In PWM signal generation, do not program the PWM channel to toggle on output compare. Toggling on output compare prevents reliable 0% duty cycle generation and removes the ability of the channel to self-correct in the event of software error or noise. Toggling on output compare can also cause incorrect PWM signal generation when changing the PWM pulse width to a new, much larger value.*

5. In the TIM status control register (TSC), clear the TIM stop bit, TSTOP.

Setting MS0B links channels 0 and 1 and configures them for buffered PWM operation. The TIM channel 0 registers (TCH0H:TCH0L) initially control the buffered PWM output. TIM status control register 0 (TSCR0) controls and monitors the PWM signal from the linked channels. MS0B takes priority over MS0A.

Clearing the toggle-on-overflow bit, TOVx, inhibits output toggles on TIM overflows. Subsequent output compares try to force the output to a state it is already in and have no effect. The result is a 0% duty cycle output.

Setting the channel x maximum duty cycle bit (CHxMAX) and clearing the TOVx bit generates a 100% duty cycle output. (See [10.10.4 TIM Channel Status and Control Registers \(TSC0:TSC1\)](#).)

10.6 Interrupts

The following TIM sources can generate interrupt requests:

- TIM overflow flag (TOF) — The TOF bit is set when the TIM counter value rolls over to \$0000 after matching the value in the TIM counter modulo registers. The TIM overflow interrupt enable bit, TOIE, enables TIM overflow CPU interrupt requests. TOF and TOIE are in the TIM status and control register.
- TIM channel flags (CH1F:CH0F) — The CHxF bit is set when an input capture or output compare occurs on channel x. Channel x TIM CPU interrupt requests are controlled by the channel x interrupt enable bit, CHxIE. Channel x TIM CPU interrupt requests are enabled when CHxIE=1. CHxF and CHxIE are in the TIM channel x status and control register.

10.7 Wait Mode

The WAIT instruction puts the MCU in low-power-consumption standby mode.

The TIM remains active after the execution of a WAIT instruction. In wait mode the TIM registers are not accessible by the CPU. Any enabled CPU interrupt request from the TIM can bring the MCU out of wait mode.

If TIM functions are not required during wait mode, reduce power consumption by stopping the TIM before executing the WAIT instruction.

10.8 TIM During Break Interrupts

A break interrupt stops the TIM counter.

The system integration module (SIM) controls whether status bits in other modules can be cleared during the break state. The BCFE bit in the break flag control register (BFCR) enables software to clear status bits during the break state. (See [7.8.3 Break Flag Control Register \(BFCR\)](#).)

To allow software to clear status bits during a break interrupt, write a logic one to the BCFE bit. If a status bit is cleared during the break state, it remains cleared when the MCU exits the break state.

To protect status bits during the break state, write a logic zero to the BCFE bit. With BCFE at logic zero (its default state), software can read and write I/O registers during the break state without affecting status bits. Some status bits have a two-step read/write clearing procedure. If software does the first step on such a bit before the break, the bit cannot change during the break state as long as BCFE is at logic zero. After the break, doing the second step clears the status bit.

10.9 I/O Signals

Port D shares two of its pins with the TIM. The two TIM channel I/O pins are PTD4/TCH0 and PTD5/TCH1.

Each channel I/O pin is programmable independently as an input capture pin or an output compare pin. PTD4/TCH0 can be configured as a buffered output compare or buffered PWM pin.

10.10 I/O Registers

The following I/O registers control and monitor operation of the TIM:

- TIM status and control register (TSC)
- TIM control registers (TCNTH:TCNTL)
- TIM counter modulo registers (TMODH:TMODL)
- TIM channel status and control registers (TSC0 and TSC1)
- TIM channel registers (TCH0H:TCH0L and TCH1H:TCH1L)

10.10.1 TIM Status and Control Register (TSC)

The TIM status and control register does the following:

- Enables TIM overflow interrupts
- Flags TIM overflows
- Stops the TIM counter
- Resets the TIM counter
- Prescales the TIM counter clock

Address: \$0020

	Bit 7	6	5	4	3	2	1	Bit 0
Read:	TOF	TOIE	TSTOP	0	0	PS2	PS1	PS0
Write:	0			TRST				
Reset:	0	0	1	0	0	0	0	0

 = Unimplemented

Figure 10-4. TIM Status and Control Register (TSC)

TOF — TIM Overflow Flag Bit

This read/write flag is set when the TIM counter resets to \$0000 after reaching the modulo value programmed in the TIM counter modulo registers. Clear TOF by reading the TIM status and control register when TOF is set and then writing a logic zero to TOF. If another TIM

overflow occurs before the clearing sequence is complete, then writing logic zero to TOF has no effect. Therefore, a TOF interrupt request cannot be lost due to inadvertent clearing of TOF. Reset clears the TOF bit. Writing a logic one to TOF has no effect.

1 = TIM counter has reached modulo value

0 = TIM counter has not reached modulo value

TOIE — TIM Overflow Interrupt Enable Bit

This read/write bit enables TIM overflow interrupts when the TOF bit becomes set. Reset clears the TOIE bit.

1 = TIM overflow interrupts enabled

0 = TIM overflow interrupts disabled

TSTOP — TIM Stop Bit

This read/write bit stops the TIM counter. Counting resumes when TSTOP is cleared. Reset sets the TSTOP bit, stopping the TIM counter until software clears the TSTOP bit.

1 = TIM counter stopped

0 = TIM counter active

NOTE: *Do not set the TSTOP bit before entering wait mode if the TIM is required to exit wait mode.*

TRST — TIM Reset Bit

Setting this write-only bit resets the TIM counter and the TIM prescaler. Setting TRST has no effect on any other registers. Counting resumes from \$0000. TRST is cleared automatically after the TIM counter is reset and always reads as logic zero. Reset clears the TRST bit.

1 = Prescaler and TIM counter cleared

0 = No effect

NOTE: *Setting the TSTOP and TRST bits simultaneously stops the TIM counter at a value of \$0000.*

PS[2:0] — Prescaler Select Bits

These read/write bits select one of the seven prescaler outputs as the input to the TIM counter as [Table 10-2](#) shows. Reset clears the PS[2:0] bits.

Table 10-2. Prescaler Selection

PS2	PS1	PS0	TIM Clock Source
0	0	0	Internal Bus Clock ÷ 1
0	0	1	Internal Bus Clock ÷ 2
0	1	0	Internal Bus Clock ÷ 4
0	1	1	Internal Bus Clock ÷ 8
1	0	0	Internal Bus Clock ÷ 16
1	0	1	Internal Bus Clock ÷ 32
1	1	0	Internal Bus Clock ÷ 64
1	1	1	Not available

10.10.2 TIM Counter Registers (TCNTH:TCNTL)

The two read-only TIM counter registers contain the high and low bytes of the value in the TIM counter. Reading the high byte (TCNTH) latches the contents of the low byte (TCNTL) into a buffer. Subsequent reads of TCNTH do not affect the latched TCNTL value until TCNTL is read.

Reset clears the TIM counter registers. Setting the TIM reset bit (TRST) also clears the TIM counter registers.

NOTE: *If you read TCNTH during a break interrupt, be sure to unlatch TCNTL by reading TCNTL before exiting the break interrupt. Otherwise, TCNTL retains the value latched during the break.*

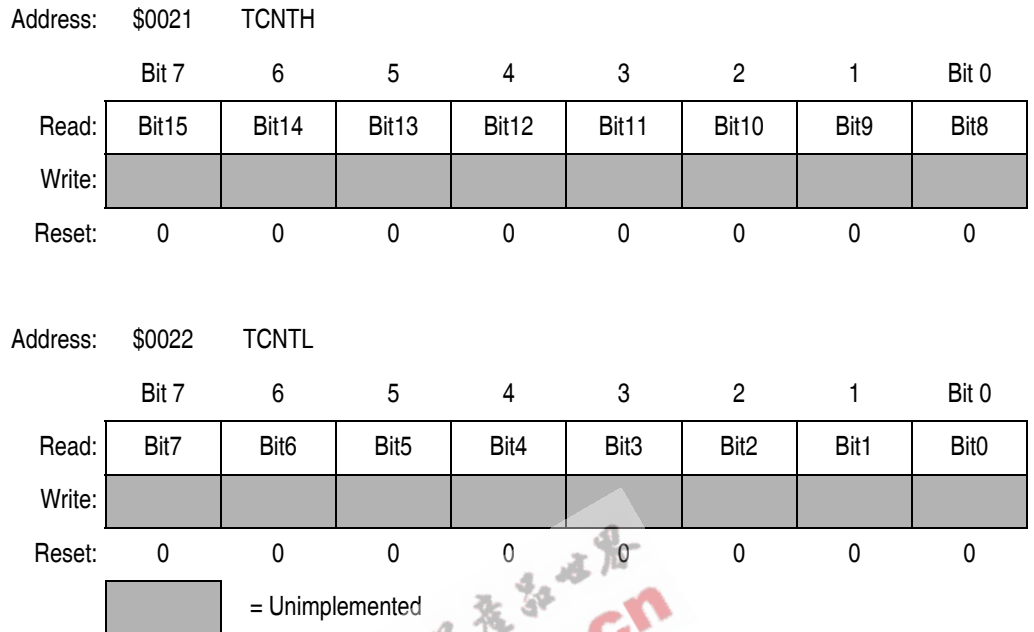

Figure 10-5. TIM Counter Registers (TCNTH:TCNTL)

10.10.3 TIM Counter Modulo Registers (TMODH:TMODL)

The read/write TIM modulo registers contain the modulo value for the TIM counter. When the TIM counter reaches the modulo value, the overflow flag (TOF) becomes set, and the TIM counter resumes counting from \$0000 at the next clock. Writing to the high byte (TMODH) inhibits the TOF bit and overflow interrupts until the low byte (TMODL) is written. Reset sets the TIM counter modulo registers.

Address:	\$0023 TMODH							
	Bit 7	6	5	4	3	2	1	Bit 0
Read:	Bit15	Bit14	Bit13	Bit12	Bit11	Bit10	Bit9	Bit8
Write:								
Reset:	1	1	1	1	1	1	1	1

Address:	\$0024 TMODL							
	Bit 7	6	5	4	3	2	1	Bit 0
Read:	Bit7	Bit6	Bit5	Bit4	Bit3	Bit2	Bit1	Bit0
Write:								
Reset:	1	1	1	1	1	1	1	1

Figure 10-6. TIM Counter Modulo Registers (TMODH:TMODL)

NOTE: Reset the TIM counter before writing to the TIM counter modulo registers.

10.10.4 TIM Channel Status and Control Registers (TSC0:TSC1)

Each of the TIM channel status and control registers does the following:

- Flags input captures and output compares
- Enables input capture and output compare interrupts
- Selects input capture, output compare, or PWM operation
- Selects high, low, or toggling output on output compare
- Selects rising edge, falling edge, or any edge as the active input capture trigger
- Selects output toggling on TIM overflow
- Selects 100% PWM duty cycle
- Selects buffered or unbuffered output compare/PWM operation

Address:	\$0025	TSC0							
		Bit 7	6	5	4	3	2	1	Bit 0
Read:	CH0F	CH0IE	MS0B	MS0A	ELS0B	ELS0A	TOV0	CH0MAX	
Write:	0								
Reset:	0	0	0	0	0	0	0	0	0

Address:	\$0028	TSC1							
		Bit 7	6	5	4	3	2	1	Bit 0
Read:	CH1F	CH1IE	0	MS1A	ELS1B	ELS1A	TOV1	CH1MAX	
Write:	0								
Reset:	0	0	0	0	0	0	0	0	0

= Unimplemented

Figure 10-7. TIM Channel Status and Control Registers (TSC0:TSC1)

CHxF — Channel x Flag Bit

When channel x is an input capture channel, this read/write bit is set when an active edge occurs on the channel x pin. When channel x is an output compare channel, CHxF is set when the value in the TIM counter registers matches the value in the TIM channel x registers.

When TIM CPU interrupt requests are enabled (CHxIE=1), clear CHxF by reading the TIM channel x status and control register with CHxF set and then writing a logic zero to CHxF. If another interrupt request occurs before the clearing sequence is complete, then writing logic zero to CHxF has no effect. Therefore, an interrupt request cannot be lost due to inadvertent clearing of CHxF.

Reset clears the CHxF bit. Writing a logic one to CHxF has no effect.

- 1 = Input capture or output compare on channel x
- 0 = No input capture or output compare on channel x

CHxIE — Channel x Interrupt Enable Bit

This read/write bit enables TIM CPU interrupt service requests on channel x. Reset clears the CHxIE bit.

- 1 = Channel x CPU interrupt requests enabled
- 0 = Channel x CPU interrupt requests disabled

MSxB — Mode Select Bit B

This read/write bit selects buffered output compare/PWM operation. MSxB exists only in the TIM channel 0 status and control register.

Setting MS0B disables the channel 1 status and control register and reverts TCH1 to general-purpose I/O.

Reset clears the MSxB bit.

1 = Buffered output compare/PWM operation enabled

0 = Buffered output compare/PWM operation disabled

MSxA — Mode Select Bit A

When ELSxB:A \neq 00, this read/write bit selects either input capture operation or unbuffered output compare/PWM operation.

See [Table 10-3](#).

1 = Unbuffered output compare/PWM operation

0 = Input capture operation

When ELSxB:A = 00, this read/write bit selects the initial output level of the TCHx pin. (See [Table 10-3](#).) Reset clears the MSxA bit.

1 = Initial output level low

0 = Initial output level high

NOTE: *Before changing a channel function by writing to the MSxB or MSxA bit, set the TSTOP and TRST bits in the TIM status and control register (TSC).*

ELSxB and ELSxA — Edge/Level Select Bits

When channel x is an input capture channel, these read/write bits control the active edge-sensing logic on channel x.

When channel x is an output compare channel, ELSxB and ELSxA control the channel x output behavior when an output compare occurs.

When ELSxB and ELSxA are both clear, channel x is not connected to an I/O port, and pin TCHx is available as a general-purpose I/O pin.

[Table 10-3](#) shows how ELSxB and ELSxA work. Reset clears the ELSxB and ELSxA bits.

Table 10-3. Mode, Edge, and Level Selection

MSxB	MSxA	ELSxB	ELSxA	Mode	Configuration
X	0	0	0	Output Preset	Pin under Port Control; Initial Output Level High
X	1	0	0		Pin under Port Control; Initial Output Level Low
0	0	0	1	Input Capture	Capture on Rising Edge Only
0	0	1	0		Capture on Falling Edge Only
0	0	1	1		Capture on Rising or Falling Edge
0	1	0	1	Output Compare or PWM	Toggle Output on Compare
0	1	1	0		Clear Output on Compare
0	1	1	1		Set Output on Compare
1	X	0	1	Buffered Output Compare or Buffered PWM	Toggle Output on Compare
1	X	1	0		Clear Output on Compare
1	X	1	1		Set Output on Compare

NOTE: Before enabling a TIM channel register for input capture operation, make sure that the TCHx pin is stable for at least two bus clocks.

TOVx — Toggle-On-Overflow Bit

When channel x is an output compare channel, this read/write bit controls the behavior of the channel x output when the TIM counter overflows. When channel x is an input capture channel, TOVx has no effect. Reset clears the TOVx bit.

1 = Channel x pin toggles on TIM counter overflow.

0 = Channel x pin does not toggle on TIM counter overflow.

NOTE: When TOVx is set, a TIM counter overflow takes precedence over a channel x output compare if both occur at the same time.

CHxMAX — Channel x Maximum Duty Cycle Bit

When the TOVx bit is at logic zero, setting the CHxMAX bit forces the duty cycle of buffered and unbuffered PWM signals to 100%. As [Figure 10-8](#) shows, the CHxMAX bit takes effect in the cycle after it is set or cleared. The output stays at the 100% duty cycle level until the cycle after CHxMAX is cleared.

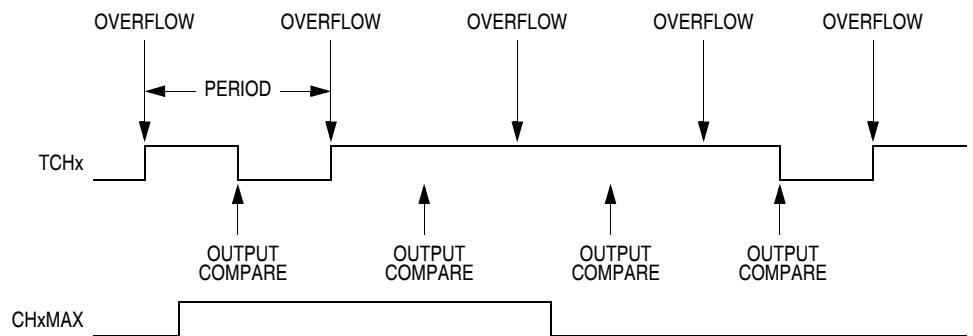

Figure 10-8. CHxMAX Latency

10.10.5 TIM Channel Registers (TCH0H/L:TCH1H/L)

These read/write registers contain the captured TIM counter value of the input capture function or the output compare value of the output compare function. The state of the TIM channel registers after reset is unknown.

In input capture mode ($MSxB:MSxA = 0:0$), reading the high byte of the TIM channel x registers (TCHxH) inhibits input captures until the low byte (TCHxL) is read.

In output compare mode ($MSxB:MSxA \neq 0:0$), writing to the high byte of the TIM channel x registers (TCHxH) inhibits output compares until the low byte (TCHxL) is written.

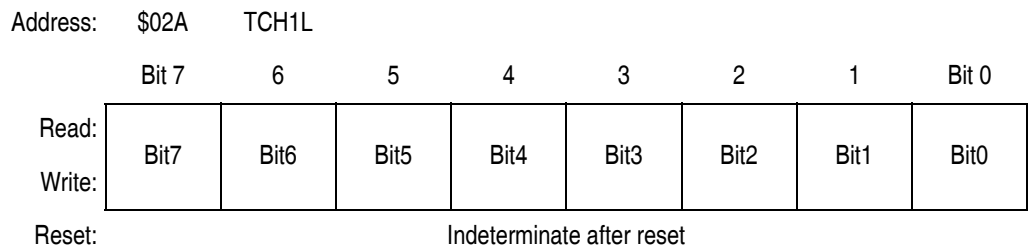
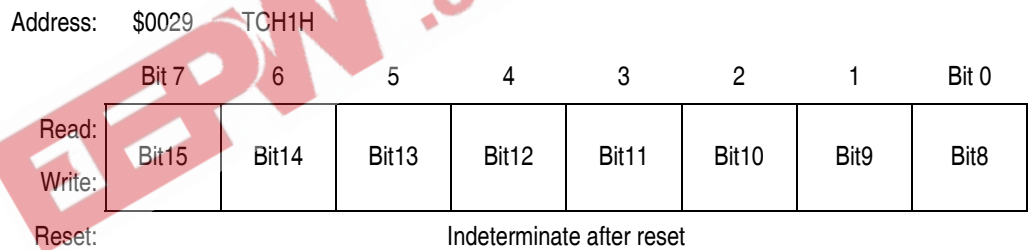
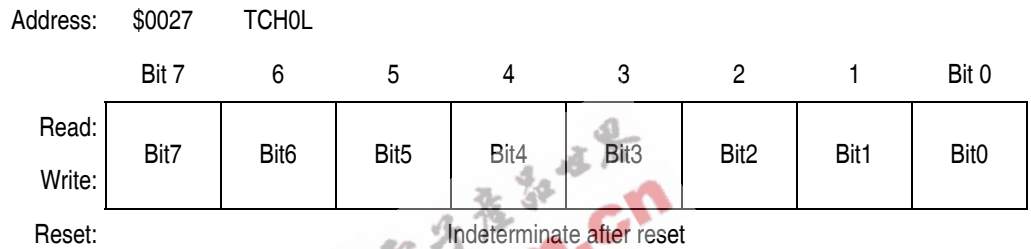
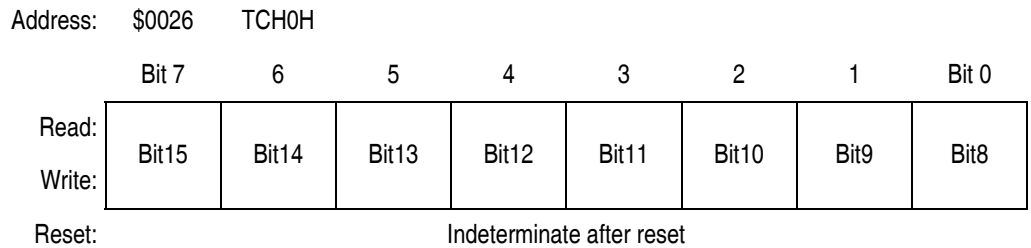

Figure 10-9. TIM Channel Registers (TCH0H/L:TCH1H/L)

Section 11. Analog-to-Digital Converter (ADC)

11.1 Contents

11.2	Introduction	127
11.3	Features	128
11.4	Functional Description	128
11.4.1	ADC Port I/O Pins	129
11.4.2	Voltage Conversion	130
11.4.3	Conversion Time	130
11.4.4	Continuous Conversion	130
11.4.5	Accuracy and Precision	131
11.5	Interrupts	131
11.6	Low-Power Modes	131
11.6.1	Wait Mode	131
11.6.2	Stop Mode	131
11.7	I/O Signals	131
11.7.1	ADC Voltage In (ADCVIN)	132
11.8	I/O Registers	132
11.8.1	ADC Status and Control Register	132
11.8.2	ADC Data Register	134
11.8.3	ADC Input Clock Register	135

11.2 Introduction

This section describes the analog-to-digital converter (ADC). The ADC is an 8-bit, 12-channels analog-to-digital converter.

11.3 Features

Features of the ADC module include:

- 12 channels with multiplexed input
- Linear successive approximation with monotonicity
- 8-bit resolution
- Single or continuous conversion
- Conversion complete flag or conversion complete interrupt
- Selectable ADC clock

Addr.	Register Name		Bit 7	6	5	4	3	2	1	Bit 0
\$003C	ADC Status and Control Register (ADSCR)	Read:	COCO	AIEN	ADCO	CH4	CH3	CH2	CH1	CH0
		Write:								
		Reset:	0	0	0	1	1	1	1	1
\$003D	ADC Data Register (ADR)	Read:	AD7	AD6	AD5	AD4	AD3	AD2	AD1	AD0
		Write:								
		Reset:	Indeterminate after reset							
\$003E	ADC Input Clock Register (ADICLK)	Read:				0	0	0	0	0
		Write:	ADIV2	ADIV1	ADIV0					
		Reset:	0	0	0	0	0	0	0	0

Figure 11-1. ADC I/O Register Summary

11.4 Functional Description

Twelve ADC channels are available for sampling external sources at pins PTB0–PTB7 and PTD0–PTD3. An analog multiplexer allows the single ADC converter to select one of the 12 ADC channels as ADC voltage input (ADCVIN). ADCVIN is converted by the successive approximation register-based counters. The ADC resolution is 8 bits. When the conversion is completed, ADC puts the result in the ADC data register and sets a flag or generates an interrupt. [Figure 11-2](#) shows a block diagram of the ADC.

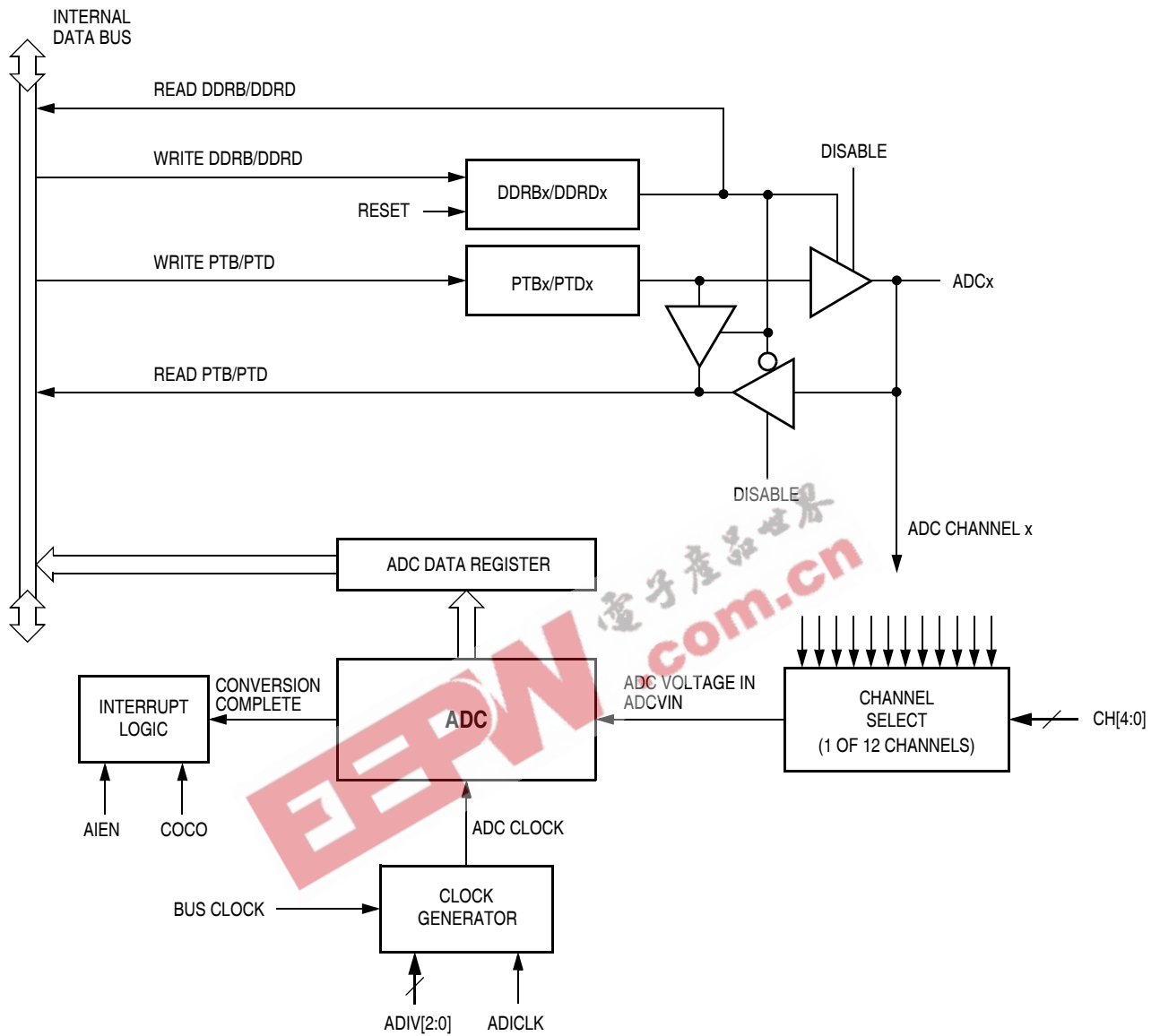

Figure 11-2. ADC Block Diagram

11.4.1 ADC Port I/O Pins

PTB0–PTB7 and PTD0–PTD3 are general-purpose I/O pins that are shared with the ADC channels. The channel select bits (ADC Status and Control register, \$003C), define which ADC channel/port pin will be used as the input signal. The ADC overrides the port I/O logic by forcing that pin as input to the ADC. The remaining ADC channels/port pins are controlled by the port I/O logic and can be used as general-purpose I/O.

Writes to the port register or DDR will not have any affect on the port pin that is selected by the ADC. Read of a port pin which is in use by the ADC will return a logic 0 if the corresponding DDR bit is at logic 0. If the DDR bit is at logic 1, the value in the port data latch is read.

11.4.2 Voltage Conversion

When the input voltage to the ADC equals V_{DD} , the ADC converts the signal to \$FF (full scale). If the input voltage equals V_{SS} , the ADC converts it to \$00. Input voltages between V_{DD} and V_{SS} are a straight-line linear conversion. All other input voltages will result in \$FF if greater than V_{DD} and \$00 if less than V_{SS} .

NOTE: *Input voltage should not exceed the analog supply voltages.*

11.4.3 Conversion Time

Sixteen ADC internal clocks are required to perform one conversion. The ADC starts a conversion on the first rising edge of the ADC internal clock immediately following a write to the ADSCR. If the ADC internal clock is selected to run at 1 MHz, then one conversion will take 16 μ s to complete. With a 1 MHz ADC internal clock the maximum sample rate is 62.5kHz.

$$\text{Conversion Time} = \frac{16 \text{ ADC Clock Cycles}}{\text{ADC Clock Frequency}}$$

$$\text{Number of Bus Cycles} = \text{Conversion Time} \times \text{Bus Frequency}$$

11.4.4 Continuous Conversion

In the continuous conversion mode, the ADC continuously converts the selected channel filling the ADC data register with new data after each conversion. Data from the previous conversion will be overwritten whether that data has been read or not. Conversions will continue until the ADCO bit is cleared. The COCO bit (ADC Status & Control register, \$003C) is set after each conversion and can be cleared by writing the ADC status and control register or reading of the ADC data register.

11.4.5 Accuracy and Precision

The conversion process is monotonic and has no missing codes.

11.5 Interrupts

When the AIEN bit is set, the ADC module is capable of generating a CPU interrupt after each ADC conversion. A CPU interrupt is generated if the COCO bit is at logic 0. The COCO bit is not used as a conversion complete flag when interrupts are enabled.

11.6 Low-Power Modes

The following subsections describe the ADC in low-power modes.

11.6.1 Wait Mode

The ADC continues normal operation during wait mode. Any enabled CPU interrupt request from the ADC can bring the MCU out of wait mode. If the ADC is not required to bring the MCU out of wait mode, power down the ADC by setting the CH[4:0] bits in the ADC Status and Control register to logic 1's before executing the WAIT instruction.

11.6.2 Stop Mode

The ADC module is inactive after the execution of a STOP instruction. Any pending conversion is aborted. ADC conversions resume when the MCU exits stop mode. Allow one conversion cycle to stabilize the analog circuitry before attempting a new ADC conversion after exiting stop mode.

11.7 I/O Signals

The ADC module has 12 channels that are shared with I/O port B and port D.

11.7.1 ADC Voltage In (ADCVIN)

ADCVIN is the input voltage signal from one of the 12 ADC channels to the ADC module.

11.8 I/O Registers

These I/O registers control and monitor ADC operation:

- ADC Status and Control register (ADSCR)
- ADC data register (ADR)
- ADC clock register (ADICLK)

11.8.1 ADC Status and Control Register

The following paragraphs describe the function of the ADC Status and Control register.

Address: \$003C

	Bit 7	6	5	4	3	2	1	Bit 0
Read:	COCO	AIEN	ADCO	CH4	CH3	CH2	CH1	CH0
Write:								
Reset:	0	0	0	1	1	1	1	1

 = Unimplemented

Figure 11-3. ADC Status and Control Register (ADSCR)

COCO — Conversions Complete Bit

When the AIEN bit is a logic 0, the COCO is a read-only bit which is set each time a conversion is completed. This bit is cleared whenever the ADC status and control register is written or whenever the ADC data register is read. Reset clears this bit.

1 = conversion completed (AIEN = 0)

0 = conversion not completed (AIEN = 0)

When the AIEN bit is a logic 1 (CPU interrupt enabled), the COCO is a read-only bit, and will always be logic 0 when read.

AIEN — ADC Interrupt Enable Bit

When this bit is set, an interrupt is generated at the end of an ADC conversion. The interrupt signal is cleared when the data register is read or the status/control register is written. Reset clears the AIEN bit.

- 1 = ADC interrupt enabled
- 0 = ADC interrupt disabled

ADCO — ADC Continuous Conversion Bit

When set, the ADC will convert samples continuously and update the ADR register at the end of each conversion. Only one conversion is allowed when this bit is cleared. Reset clears the ADCO bit.

- 1 = Continuous ADC conversion
- 0 = One ADC conversion

ADCH[4:0] — ADC Channel Select Bits

ADCH4, ADCH3, ADCH2, ADCH1, and ADCH0 form a 5-bit field which is used to select one of the ADC channels. The five channel select bits are detailed in the following table. Care should be taken when using a port pin as both an analog and a digital input simultaneously to prevent switching noise from corrupting the analog signal. (See [Table 11-1.](#))

The ADC subsystem is turned off when the channel select bits are all set to one. This feature allows for reduced power consumption for the MCU when the ADC is not used. Reset sets all of these bits to a logic 1.

NOTE: *Recovery from the disabled state requires one conversion cycle to stabilize.*

Table 11-1. MUX Channel Select

CH4	CH3	CH2	CH1	CH0	ADC Channel	Input Select
0	0	0	0	0	ADC0	PTB0
0	0	0	0	1	ADC1	PTB1
0	0	0	1	0	ADC2	PTB2
0	0	0	1	1	ADC3	PTB3
0	0	1	0	0	ADC4	PTB4
0	0	1	0	1	ADC5	PTB5
0	0	1	1	0	ADC6	PTB6
0	0	1	1	1	ADC7	PTB7
0	1	0	0	0	ADC8	PTD3
0	1	0	0	1	ADC9	PTD2
0	1	0	1	0	ADC10	PTD1
0	1	0	1	1	ADC11	PTD0
0	1	1	0	0	—	Unused (see Note 1)
:	:	:	:	:	—	
1	1	0	1	0	—	Reserved
1	1	0	1	1	—	Unused
1	1	1	0	0	—	V_{DDA} (see Note 2)
1	1	1	0	1	—	V_{SSA} (see Note 2)
1	1	1	1	0	—	ADC power off
1	1	1	1	1	—	ADC power off

NOTES:

1. If any unused channels are selected, the resulting ADC conversion will be unknown.
2. The voltage levels supplied from internal reference nodes as specified in the table are used to verify the operation of the ADC converter both in production test and for user applications.

11.8.2 ADC Data Register

One 8-bit result register is provided. This register is updated each time an ADC conversion completes.

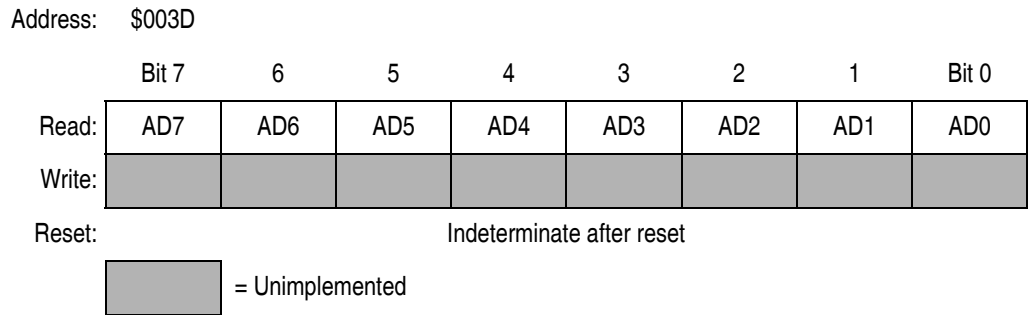

Figure 11-4. ADC Data Register (ADR)

11.8.3 ADC Input Clock Register

This register selects the clock frequency for the ADC.

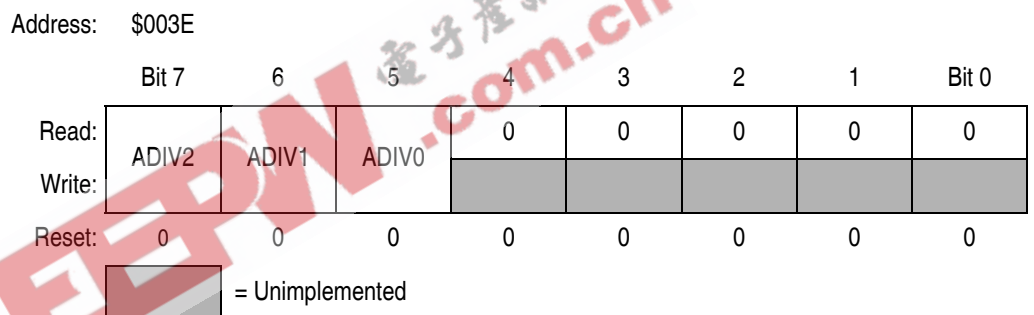

Figure 11-5. ADC Input Clock Register (ADICLK)

ADIV2:ADIV0 — ADC Clock Prescaler Bits

ADIV2, ADIV1, and ADIV0 form a 3-bit field which selects the divide ratio used by the ADC to generate the internal ADC clock. [Table 11-2](#) shows the available clock configurations. The ADC clock should be set to approximately 1 MHz.

Table 11-2. ADC Clock Divide Ratio

ADIV2	ADIV1	ADIV0	ADC Clock Rate
0	0	0	ADC Input Clock ÷ 1
0	0	1	ADC Input Clock ÷ 2
0	1	0	ADC Input Clock ÷ 4
0	1	1	ADC Input Clock ÷ 8
1	X	X	ADC Input Clock ÷ 16

X = don't care

EEPW 电子产品世界
.com.cn

Section 12. I/O Ports

12.1 Contents

12.2	Introduction	137
12.3	Port A	138
12.3.1	Port A Data Register (PTA)	139
12.3.2	Data Direction Register A (DDRA)	140
12.3.3	Port A Input Pull-up Enable Register (PTAPUE)	141
12.4	Port B	143
12.4.1	Port B Data Register (PTB)	143
12.4.2	Data Direction Register B (DDRB)	143
12.5	Port D	145
12.5.1	Port D Data Register (PTD)	145
12.5.2	Data Direction Register D (DDRD)	146
12.5.3	Port D Control Register (PDCR)	147

12.2 Introduction

Twenty three bidirectional input-output (I/O) pins form three parallel ports. All I/O pins are programmable as inputs or outputs.

NOTE: *Connect any unused I/O pins to an appropriate logic level, either V_{DD} or V_{SS} . Although the I/O ports do not require termination for proper operation, termination reduces excess current consumption and the possibility of electrostatic damage.*

Addr.	Register Name	Bit 7	6	5	4	3	2	1	Bit 0	
\$0000	Port A Data Register (PTA)	Read:	0	PTA6	PTA5	PTA4	PTA3	PTA2	PTA1	PTA0
		Write:								
		Reset:	Unaffected by reset							
\$0001	Port B Data Register (PTB)	Read:	PTB7	PTB6	PTB5	PTB4	PTB3	PTB2	PTB1	PTB0
		Write:								
		Reset:	Unaffected by reset							
\$0003	Port D Data Register (PTD)	Read:	PTD7	PTD6	PTD5	PTD4	PTD3	PTD2	PTD1	PTD0
		Write:								
		Reset:	Unaffected by reset							
\$0004	Data Direction Register A (DDRA)	Read:	0	DDRA6	DDRA5	DDRA4	DDRA3	DDRA2	DDRA1	DDRA0
		Write:								
		Reset:	0	0	0	0	0	0	0	0
\$0005	Data Direction Register B (DDRB)	Read:	DDRB7	DDRB6	DDRB5	DDRB4	DDRB3	DDRB2	DDRB1	DDRB0
		Write:								
		Reset:	0	0	0	0	0	0	0	0
\$0007	Data Direction Register D (DDRD)	Read:	DDRD7	DDRD6	DDRD5	DDRD4	DDRD3	DDRD2	DDRD1	DDRD0
		Write:								
		Reset:	0	0	0	0	0	0	0	0
\$000A	Port D Control Register (PDCR)	Read:	0	0	0	0	SLOWD7	SLOWD6	PTDPU7	PTDPU6
		Write:								
		Reset:	0	0	0	0	0	0	0	0
\$000D	Port A Input Pull-up Enable Register (PTAPUE)	Read:	PTA6EN	PTAPUE6	PTAPUE5	PTAPUE4	PTAPUE3	PTAPUE2	PTAPUE1	PTAPUE0
		Write:								
		Reset:	0	0	0	0	0	0	0	0

Figure 12-1. I/O Port Register Summary

12.3 Port A

Port A is an 7-bit special function port that shares all seven of its pins with the Keyboard Interrupt (KBI) Module, **See Section 14**. Each port A pin also has software configurable pull-up device if the corresponding port pin is configured as input port. PTA0 to PTA5 has direct LED drive capability.

12.3.1 Port A Data Register (PTA)

The port A data register (PTA) contains a data latch for each of the seven port A pins.

Address: \$0000

	Bit 7	6	5	4	3	2	1	Bit 0
Read:	0	PTA6	PTA5	PTA4	PTA3	PTA2	PTA1	PTA0
Write:								
Reset:	Unaffected by Reset							
Additional Functions:			LED (Sink)	LED (Sink)	LED (Sink)	LED (Sink)	LED (Sink)	LED (Sink)
		30k pull-up	30k pull-up	30k pull-up	30k pull-up	30k pull-up	30k pull-up	30k pull-up
		Keyboard Interrupt	Keyboard Interrupt	Keyboard Interrupt	Keyboard Interrupt	Keyboard Interrupt	Keyboard Interrupt	Keyboard Interrupt

Figure 12-2. Port A Data Register (PTA)

PTA[6:0] — Port A Data Bits

These read/write bits are software programmable. Data direction of each port A pin is under the control of the corresponding bit in data direction register A. Reset has no effect on port A data.

KBI[6:0] — Port A Keyboard Interrupts

The keyboard interrupt enable bits, KBIE6-KBIE0, in the keyboard interrupt control register (KBAIER) enable the port A pins as external interrupt pins, (see [Section 14. Keyboard Interrupt Module \(KBI\)](#)).

12.3.2 Data Direction Register A (DDRA)

Data direction register A determines whether each port A pin is an input or an output. Writing a logic one to a DDRA bit enables the output buffer for the corresponding port A pin; a logic zero disables the output buffer.

Address: \$0004

	Bit 7	6	5	4	3	2	1	Bit 0
Read:	0	DDRA6	DDRA5	DDRA4	DDRA3	DDRA2	DDRA1	DDRA0
Write:								
Reset:	0	0	0	0	0	0	0	0

Figure 12-3. Data Direction Register A (DDRA)

DDRA[6:0] — Data Direction Register A Bits

These read/write bits control port A data direction. Reset clears DDRA[6:0], configuring all port A pins as inputs.

1 = Corresponding port A pin configured as output

0 = Corresponding port A pin configured as input

NOTE: *Avoid glitches on port A pins by writing to the port A data register before changing data direction register A bits from 0 to 1.*

Figure 12-4 shows the port A I/O logic.

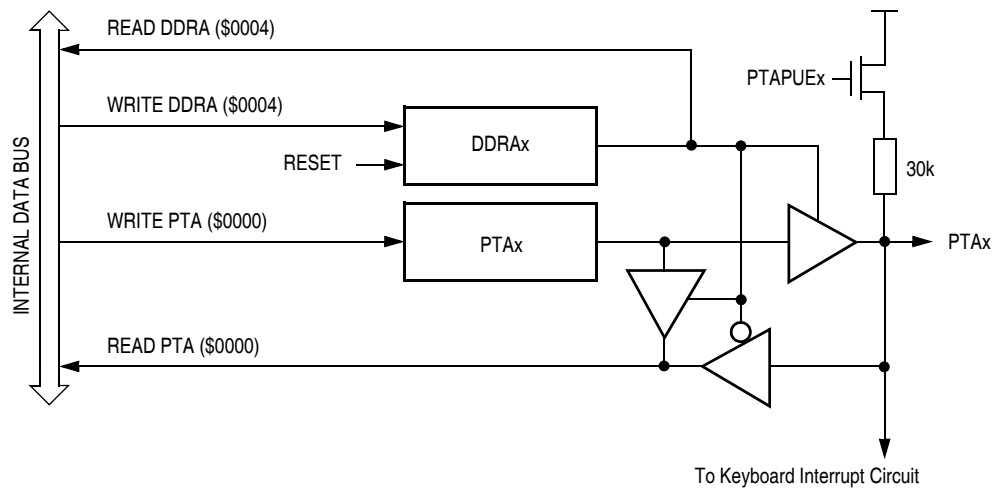

Figure 12-4. Port A I/O Circuit

When DDRAx is a logic 1, reading address \$0000 reads the PTAx data latch. When DDRAx is a logic 0, reading address \$0000 reads the voltage level on the pin. The data latch can always be written, regardless of the state of its data direction bit.

12.3.3 Port A Input Pull-up Enable Register (PTAPUE)

The Port A Input Pull-up Enable Register (PTAPUE) contains a software configurable pull-up device for each of the seven port A pins. Each bit is individually configurable and requires the corresponding data direction register, DDRAx be configured as input. Each pull-up device is automatically and dynamically disabled when its corresponding DDRAx bit is configured as output.

Address: \$000D

	Bit 7	6	5	4	3	2	1	Bit 0
Read:	PTA6EN	PTAPUE	PTAPUE	PTAPUE	PTAPUE	PTAPUE	PTAPUE	PTAPUE
Write:		6	5	4	3	2	2	0
Reset:	0	0	0	0	0	0	0	0

Figure 12-5. Port A Input Pull-up Enable Register (PTAPUE)

PTA6EN — Enable PTA6 on OSC2

This read/write bit configures the OSC2 pin function when RC oscillator option is selected. This bit has no effect for X-tal oscillator option.

- 1 = OSC2 pin configured for PTA6 I/O, and has all the interrupt and pull-up functions.
- 0 = OSC2 pin outputs the RC oscillator clock (RCCLK)

PTAPUE[6:0] — Port A Input Pull-up Enable bits

These read/write bits are software programmable to enable pull-up devices on port A pins

- 1 = Corresponding port A pin configured to have internal pull if its DDRA bit is set to 0
- 0 = Pull-up device is disconnected on the corresponding port A pin regardless of the state of its DDRA bit.

Table 12-1 summarizes the operation of the port B pins.

Table 12-1. Port A Pin Functions

PTAPUE Bit	DDRA Bit	PTA Bit	I/O Pin Mode	Accesses to DDRB		
				Read/Write	Read	Write
1	0	X ⁽¹⁾	Input, V _{DD} ⁽²⁾	DDRA6-DDRA0	Pin	PTA6-PTA0 ⁽³⁾
0	0	X	Input, Hi-Z ⁽⁴⁾	DDRA6-DDRA0	Pin	PTA6-PTA0 ⁽³⁾
X	1	X	Output	DDRA6-DDRA0	PTA6-PTA0	PTA6-PTA0

1. X = Don't care.
2. I/O pin pulled to V_{DD} by internal pull-up.
3. Writing affects data register, but does not affect input.
4. Hi-Z = High Impedence

12.4 Port B

Port B is an 8-bit special function port that shares all eight of its port pins with the Analog-to-Digital converter (ADC) module, **See Section 11.**

12.4.1 Port B Data Register (PTB)

The port B data register contains a data latch for each of the eight port B pins.

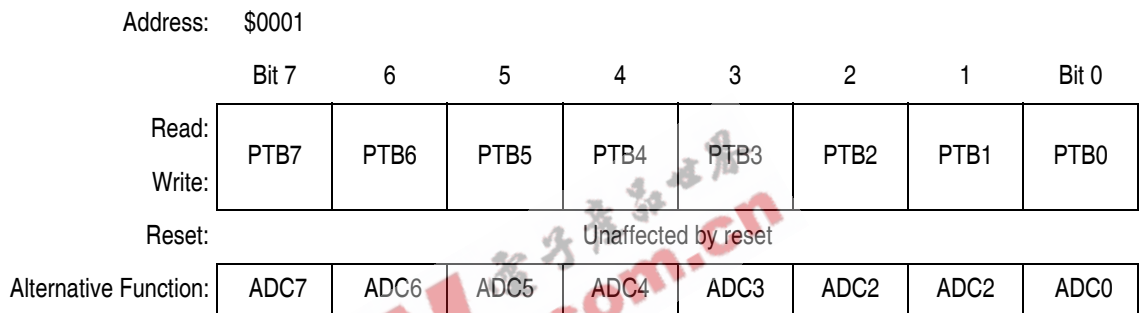

Figure 12-6. Port B Data Register (PTB)

PTB[7:0] — Port B Data Bits

These read/write bits are software programmable. Data direction of each port B pin is under the control of the corresponding bit in data direction register B. Reset has no effect on port B data.

12.4.2 Data Direction Register B (DDRB)

Data direction register B determines whether each port B pin is an input or an output. Writing a logic one to a DDRB bit enables the output buffer for the corresponding port B pin; a logic zero disables the output buffer.

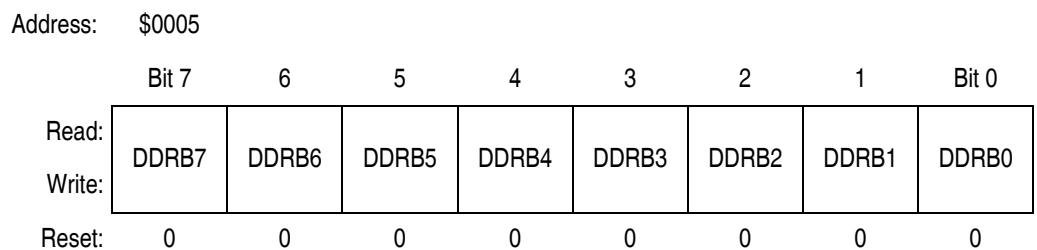

Figure 12-7. Data Direction Register B (DDRB)

DDRB[7:0] — Data Direction Register B Bits

These read/write bits control port B data direction. Reset clears DDRB[7:0], configuring all port B pins as inputs.

1 = Corresponding port B pin configured as output

0 = Corresponding port B pin configured as input

NOTE: Avoid glitches on port B pins by writing to the port B data register before changing data direction register B bits from 0 to 1. **Figure 12-8** shows the port B I/O logic.

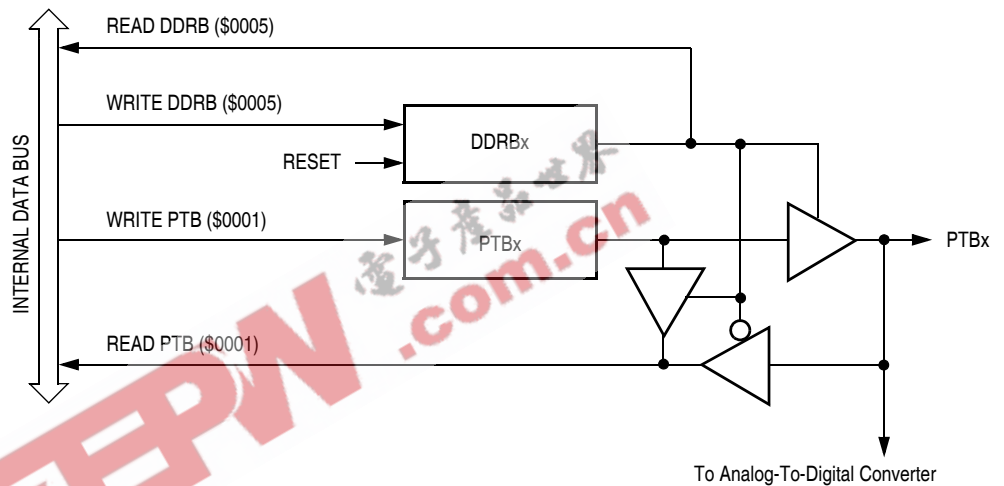

Figure 12-8. Port B I/O Circuit

When DDRBx is a logic 1, reading address \$0001 reads the PTBx data latch. When DDRBx is a logic 0, reading address \$0001 reads the voltage level on the pin. The data latch can always be written, regardless of the state of its data direction bit. **Table 12-2** summarizes the operation of the port B pins.

Table 12-2. Port B Pin Functions

DDRB Bit	PTB Bit	I/O Pin Mode	Accesses to DDRB	Accesses to PTB	
			Read/Write	Read	Write
0	X ⁽¹⁾	Input, Hi-Z ⁽²⁾	DDRB7-DDRB0	Pin	PTB[7:0] ⁽³⁾
1	X	Output	DDRB7-DDRB0	Pin	PTB[7:0]

1. X = don't care

2. Hi-Z = high impedance

3. Writing affects data register, but does not affect the input.

12.5 Port D

Port D is an 8-bit special function port that shares two of its pins with Timer Interface Module, (see [Section 10.](#)) and shares four of its pins with Analog to Digital Conversion Module (see [Section 11.](#)). PTD6 and PTD7 each has high current drive (25mA sink) and programmable pull-up. PTD2, PTD3, PTD6 and PTD7 each has LED driving capability.

12.5.1 Port D Data Register (PTD)

The port D data register contains a data latch for each of the eight port D pins.

Address: \$0003

	Bit 7	6	5	4	3	2	1	Bit 0
Read:	PTD7	PTD6	PTD5	PTD4	PTD3	PTD2	PTD1	PTD0
Write:								
Reset:								
Additional Functions	LED	LED			LED	LED		
					ADC8	ADC9	ADC10	ADC11
			TCH1	TCH0				
	25mA sink (Slow Edge)	25mA sink (Slow Edge)						
	5k pull-up	5k pull-up						

Figure 12-9. Port D Data Register (PTD)

PTD[7:0] — Port D Data Bits

These read/write bits are software programmable. Data direction of each port D pin is under the control of the corresponding bit in data direction register D. Reset has no effect on port D data.

12.5.2 Data Direction Register D (DDRD)

Data direction register D determines whether each port D pin is an input or an output. Writing a logic one to a DDRD bit enables the output buffer for the corresponding port D pin; a logic zero disables the output buffer.

Address: \$0007

	Bit 7	6	5	4	3	2	1	Bit 0
Read:	DDRD7	DDRD6	DDRD5	DDRD4	DDRD3	DDRD2	DDRD1	DDRD0
Write:	DDRD7	DDRD6	DDRD5	DDRD4	DDRD3	DDRD2	DDRD1	DDRD0
Reset:	0	0	0	0	0	0	0	0

Figure 12-10. Data Direction Register D (DDRD)

DDRD[7:0] — Data Direction Register D Bits

These read/write bits control port D data direction. Reset clears DDRD[7:0], configuring all port D pins as inputs.

- 1 = Corresponding port D pin configured as output
- 0 = Corresponding port D pin configured as input

NOTE: *Avoid glitches on port D pins by writing to the port D data register before changing data direction register D bits from 0 to 1. Figure 12-11 shows the port D I/O logic.*

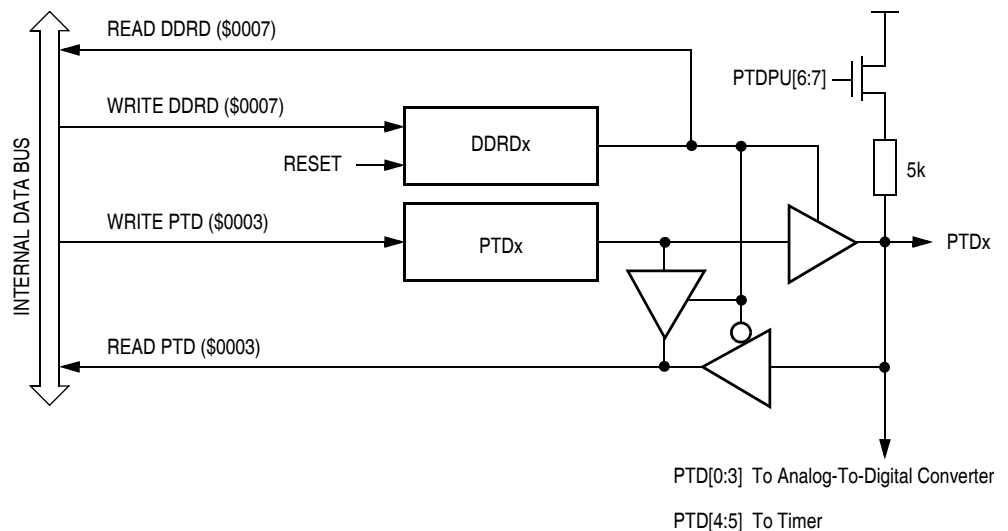

Figure 12-11. Port D I/O Circuit

When DDRDx is a logic 1, reading address \$0003 reads the PTDx data latch. When DDRDx is a logic 0, reading address \$0003 reads the voltage level on the pin. The data latch can always be written, regardless of the state of its data direction bit. [Table 12-3](#) summarizes the operation of the port D pins.

Table 12-3. Port D Pin Functions

DDRD Bit	PTD Bit	I/O Pin Mode	Accesses to DDRA	Accesses to PTD	
			Read/Write	Read	Write
0	X ⁽¹⁾	Input, Hi-Z ⁽²⁾	DDRD[7:0]	Pin	PTD[7:0] ⁽³⁾
1	X	Output	DDRD[7:0]	Pin	PTD[7:0]

1. X = don't care

2. Hi-Z = high impedance

3. Writing affects data register, but does not affect the input.

12.5.3 Port D Control Register (PDCR)

The Port D Control Register enables/disables the pull-up resistor and slow-edge high current capability of pins PTD6 and PTD7.

Address: \$000A

	Bit 7	6	5	4	3	2	1	Bit 0
Read:	0	0	0	0	SLOWD7	SLOWD6	PTDPU7	PTDPU6
Write:								
Reset:	0	0	0	0	0	0	0	0

Figure 12-12. Port D Control Register (PDCR)

SLOWDx — Slow Edge Enable

The SLOWD6 and SLOWD7 bits enable the Slow-edge, open-drain, high current output (25mA sink) of port pins PTD6 and PTD7 respectively. DDRx bit is not affected by SLOWDx.

1 = Slow edge enabled; pin is open-drain output

0 = Slow edge disabled; pin is push-pull

PTDPUx — Pull-up Enable

The PTDPU6 and PTDPU7 bits enable the 5k pull-up on PTD6 and PTD7 respectively, regardless the status of DDRDx bit.

1 = Enable 5k pull-up

0 = Disable 5k pull-up



EEPW 电子产品世界
.com.cn

Section 13. External Interrupt (IRQ)

13.1 Contents

13.2	Introduction	149
13.3	Features	149
13.4	Functional Description	150
13.4.1	$\overline{\text{IRQ1}}$ Pin	151
13.5	IRQ Module During Break Interrupts	153
13.6	IRQ Status and Control Register (ISCR)	153

13.2 Introduction

The IRQ (external interrupt) module provides a maskable interrupt input.

13.3 Features

Features of the IRQ module include the following:

- A dedicated external interrupt pin, $\overline{\text{IRQ1}}$
- IRQ1 interrupt control bits
- Hysteresis buffer
- Programmable edge-only or edge and level interrupt sensitivity
- Automatic interrupt acknowledge
- Selectable internal pullup resistor

13.4 Functional Description

A logic zero applied to the external interrupt pin can latch a CPU interrupt request. **Figure 13-1** shows the structure of the IRQ module.

Interrupt signals on the $\overline{\text{IRQ1}}$ pin are latched into the IRQ1 latch. An interrupt latch remains set until one of the following actions occurs:

- Vector fetch — A vector fetch automatically generates an interrupt acknowledge signal that clears the IRQ latch.
- Software clear — Software can clear the interrupt latch by writing to the acknowledge bit in the interrupt status and control register (ISCR). Writing a logic one to the ACK1 bit clears the IRQ1 latch.
- Reset — A reset automatically clears the interrupt latch.

The external interrupt pin is falling-edge-triggered and is software-configurable to be either falling-edge or falling-edge and low-level-triggered. The MODE1 bit in the ISCR controls the triggering sensitivity of the $\overline{\text{IRQ1}}$ pin.

When the interrupt pin is edge-triggered only, the CPU interrupt request remains set until a vector fetch, software clear, or reset occurs.

When the interrupt pin is both falling-edge and low-level-triggered, the CPU interrupt request remains set until both of the following occur:

- Vector fetch or software clear
- Return of the interrupt pin to logic one

The vector fetch or software clear may occur before or after the interrupt pin returns to logic one. As long as the pin is low, the interrupt request remains pending. A reset will clear the latch and the MODE1 control bit, thereby clearing the interrupt even if the pin stays low.

When set, the IMASK1 bit in the ISCR mask all external interrupt requests. A latched interrupt request is not presented to the interrupt priority logic unless the IMASK1 bit is clear.

NOTE: The interrupt mask (*I*) in the condition code register (CCR) masks all interrupt requests, including external interrupt requests. (See 7.6 Exception Control.)

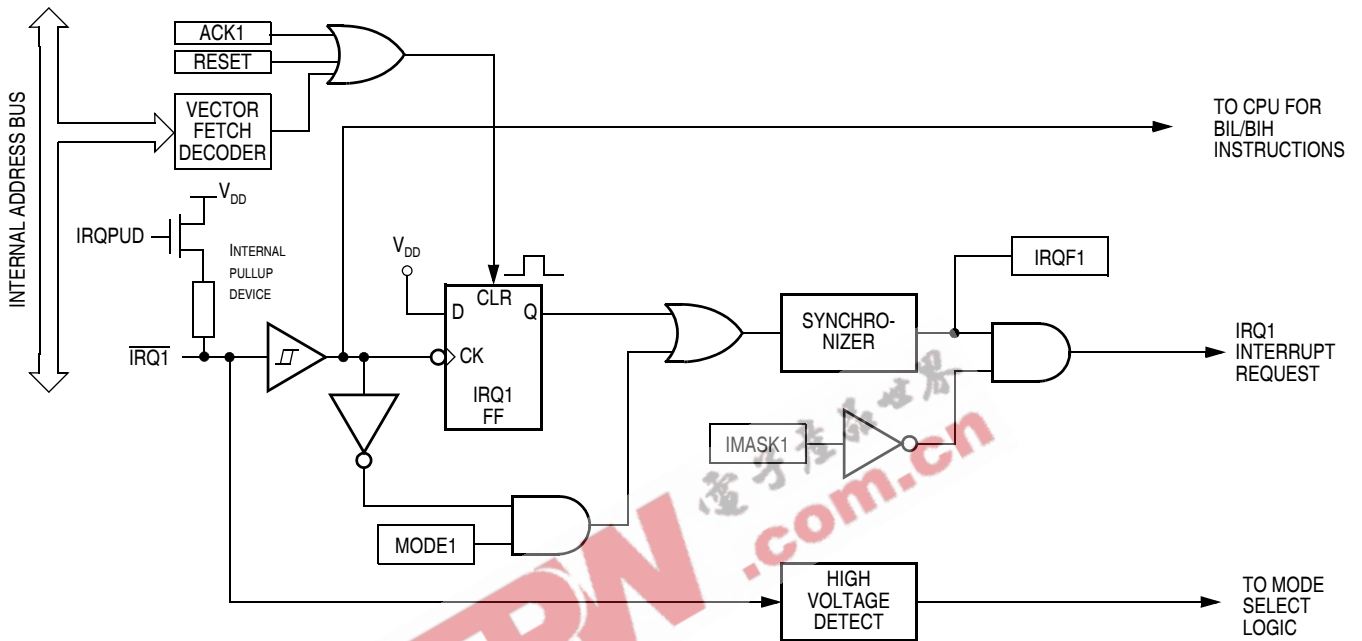

Figure 13-1. IRQ Module Block Diagram

Addr.	Register Name	Bit 7	6	5	4	3	2	1	Bit 0	
\$001D	IRQ Status and Control Register (INTSCR)	Read:	0	0	0	0	IRQF1	0	IMASK1	MODE1
		Write:	= Unimplemented							
		Reset:	0	0	0	0	0	0	0	0

= Unimplemented

Figure 13-2. IRQ I/O Register Summary

13.4.1 $\overline{\text{IRQ1}}$ Pin

A logic zero on the $\overline{\text{IRQ1}}$ pin can latch an interrupt request into the IRQ1 latch. A vector fetch, software clear, or reset clears the IRQ1 latch.

If the MODE1 bit is set, the $\overline{\text{IRQ1}}$ pin is both falling-edge-sensitive and low-level-sensitive. With MODE1 set, both of the following actions must occur to clear IRQ1:

- Vector fetch or software clear — A vector fetch generates an interrupt acknowledge signal to clear the latch. Software may generate the interrupt acknowledge signal by writing a logic one to the ACK1 bit in the interrupt status and control register (ISCR). The ACK1 bit is useful in applications that poll the $\overline{\text{IRQ1}}$ pin and require software to clear the IRQ1 latch. Writing to the ACK1 bit prior to leaving an interrupt service routine can also prevent spurious interrupts due to noise. Setting ACK1 does not affect subsequent transitions on the $\overline{\text{IRQ1}}$ pin. A falling edge that occurs after writing to the ACK1 bit latches another interrupt request. If the IRQ1 mask bit, IMASK1, is clear, the CPU loads the program counter with the vector address at locations \$FFFA and \$FFFB.
- Return of the $\overline{\text{IRQ1}}$ pin to logic one — As long as the $\overline{\text{IRQ1}}$ pin is at logic zero, IRQ1 remains active.

The vector fetch or software clear and the return of the $\overline{\text{IRQ1}}$ pin to logic one may occur in any order. The interrupt request remains pending as long as the $\overline{\text{IRQ1}}$ pin is at logic zero. A reset will clear the latch and the MODE1 control bit, thereby clearing the interrupt even if the pin stays low.

If the MODE1 bit is clear, the $\overline{\text{IRQ1}}$ pin is falling-edge-sensitive only. With MODE1 clear, a vector fetch or software clear immediately clears the IRQ1 latch.

The IRQF1 bit in the ISCR register can be used to check for pending interrupts. The IRQF1 bit is not affected by the IMASK1 bit, which makes it useful in applications where polling is preferred.

Use the BIH or BIL instruction to read the logic level on the $\overline{\text{IRQ1}}$ pin.

NOTE: *When using the level-sensitive interrupt trigger, avoid false interrupts by masking interrupt requests in the interrupt routine.*

NOTE: *An internal pull-up resistor to V_{DD} is connected to the $\overline{\text{IRQ1}}$ pin; this can be disabled by setting the IRQPUD bit in the CONFIG2 register (\$001E).*

13.5 IRQ Module During Break Interrupts

The system integration module (SIM) controls whether the IRQ1 latch can be cleared during the break state. The BCFE bit in the break flag control register (BFCR) enables software to clear the latches during the break state. (See [Section 7. System Integration Module \(SIM\)](#).)

To allow software to clear the IRQ1 latch during a break interrupt, write a logic one to the BCFE bit. If a latch is cleared during the break state, it remains cleared when the MCU exits the break state.

To protect the latches during the break state, write a logic zero to the BCFE bit. With BCFE at logic zero (its default state), writing to the ACK1 bit in the IRQ status and control register during the break state has no effect on the IRQ latch.

13.6 IRQ Status and Control Register (ISCR)

The IRQ Status and Control Register (ISCR) controls and monitors operation of the IRQ module. The ISCR has the following functions:

- Shows the state of the IRQ1 flag
- Clears the IRQ1 latch
- Masks IRQ1 and interrupt request
- Controls triggering sensitivity of the $\overline{\text{IRQ1}}$ interrupt pin

Address: \$001D

	Bit 7	6	5	4	3	2	1	Bit 0
Read:	0	0	0	0	IRQF1		IMASK1	MODE1
Write:						ACK1		
Reset:	0	0	0	0	0	0	0	0

 = Unimplemented

Figure 13-3. IRQ Status and Control Register (INTSCR)

IRQF1 — IRQ1 Flag

This read-only status bit is high when the IRQ1 interrupt is pending.

1 = $\overline{\text{IRQ1}}$ interrupt pending

0 = $\overline{\text{IRQ1}}$ interrupt not pending

ACK1 — IRQ1 Interrupt Request Acknowledge Bit

Writing a logic one to this write-only bit clears the IRQ1 latch. ACK1 always reads as logic zero. Reset clears ACK1.

IMASK1 — IRQ1 Interrupt Mask Bit

Writing a logic one to this read/write bit disables IRQ1 interrupt requests. Reset clears IMASK1.

1 = IRQ1 interrupt requests disabled

0 = IRQ1 interrupt requests enabled

MODE1 — IRQ1 Edge/Level Select Bit

This read/write bit controls the triggering sensitivity of the $\overline{\text{IRQ1}}$ pin. Reset clears MODE1.

1 = $\overline{\text{IRQ1}}$ interrupt requests on falling edges and low levels

0 = $\overline{\text{IRQ1}}$ interrupt requests on falling edges only

Address: \$001E

	Bit 7	6	5	4	3	2	1	Bit 0
Read:	IRQPUD	R	R	LVIT1	LVIT0	R	R	R
Write:								
Reset:	0	0	0	Not affected	Not affected	0	0	0
POR:	0	0	0	0	0	0	0	0

R

 = Reserved

Figure 13-4. Configuration Register 2 (CONFIG2)

IRQPUD — $\overline{\text{IRQ1}}$ Pin Pull-up control bit

1 = Internal pull-up is disconnected

0 = Internal pull-up is connected between $\overline{\text{IRQ1}}$ pin and V_{DD}

Section 14. Keyboard Interrupt Module (KBI)

14.1 Contents

14.2	Introduction	155
14.3	Features	155
14.4	Functional Description	156
14.4.1	Keyboard Initialization	158
14.4.2	Keyboard Status and Control Register	159
14.4.3	Keyboard Interrupt Enable Register	160
14.5	Wait Mode	161
14.6	Stop Mode	161
14.7	Keyboard Module During Break Interrupts	161

14.2 Introduction

The keyboard interrupt module (KBI) provides seven independently maskable external interrupts which are accessible via PTA0–PTA6 pins.

14.3 Features

Features of the keyboard interrupt module include the following:

- Seven keyboard interrupt pins with separate keyboard interrupt enable bits and one keyboard interrupt mask
- Software configurable pull-up device if input pin is configured as input port bit
- Programmable edge-only or edge- and level- interrupt sensitivity
- Exit from low-power modes

Addr.	Register Name	Bit 7	6	5	4	3	2	1	Bit 0	
\$001A	Keyboard Status and Control Register (KBSCR)	Read:	0	0	0	0	KEYF	0	IMASKK	MODEK
		Write:	[Unimplemented]					ACKK		
		Reset:	0	0	0	0	0	0	0	0
\$001B	Keyboard Interrupt Enable Register (KBIER)	Read:	0	KBIE6	KBIE5	KBIE4	KBIE3	KBIE2	KBIE1	KBIE0
		Write:	[Unimplemented]							
		Reset:	0	0	0	0	0	0	0	0

[Unimplemented]

Figure 14-1. KBI I/O Register Summary

14.4 Functional Description

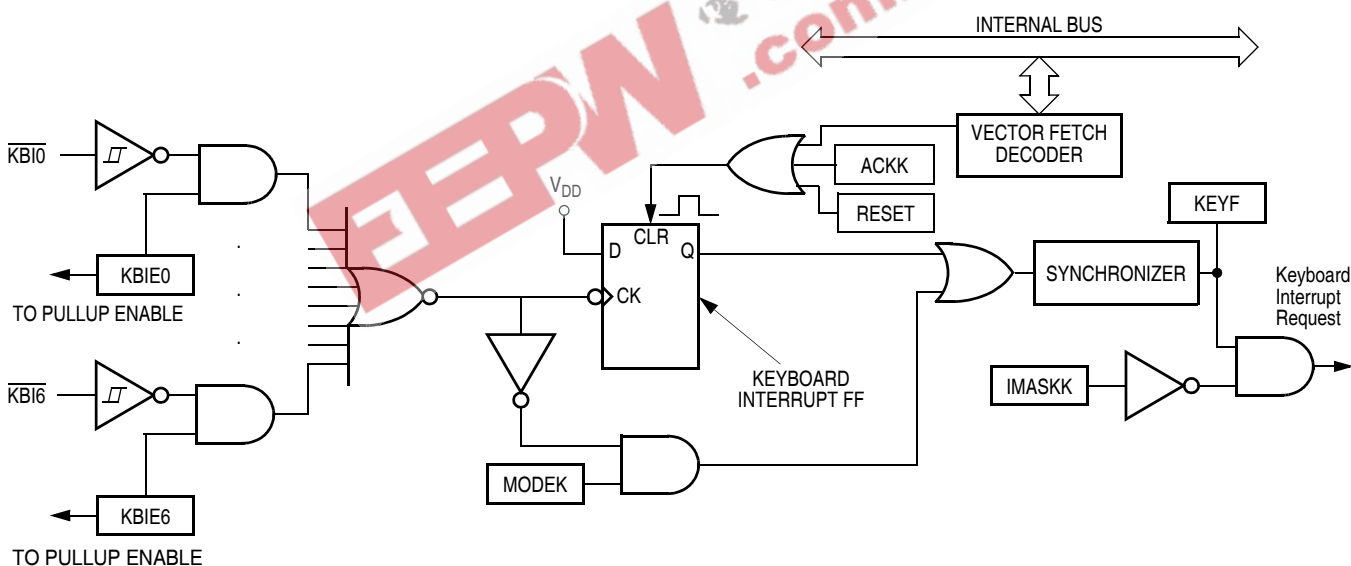

Figure 14-2. Keyboard Interrupt Block Diagram

Writing to the KBIE6–KBIE0 bits in the keyboard interrupt enable register independently enables or disables each port A pin as a keyboard interrupt pin. Enabling a keyboard interrupt pin in port A also enables its internal pull-up device irrespective of PTAPUE_x bits in the port A input pull-up enable register (see 12.3.3). A logic 0 applied to an enabled keyboard interrupt pin latches a keyboard interrupt request.

A keyboard interrupt is latched when one or more keyboard pins goes low after all were high. The MODEK bit in the keyboard status and control register controls the triggering mode of the keyboard interrupt.

- If the keyboard interrupt is edge-sensitive only, a falling edge on a keyboard pin does not latch an interrupt request if another keyboard pin is already low. To prevent losing an interrupt request on one pin because another pin is still low, software can disable the latter pin while it is low.
- If the keyboard interrupt is falling edge- and low level-sensitive, an interrupt request is present as long as any keyboard pin is low.

If the MODEK bit is set, the keyboard interrupt pins are both falling edge- and low level-sensitive, and both of the following actions must occur to clear a keyboard interrupt request:

- Vector fetch or software clear — A vector fetch generates an interrupt acknowledge signal to clear the interrupt request. Software may generate the interrupt acknowledge signal by writing a logic 1 to the ACKK bit in the keyboard status and control register KBSCR. The ACKK bit is useful in applications that poll the keyboard interrupt pins and require software to clear the keyboard interrupt request. Writing to the ACKK bit prior to leaving an interrupt service routine can also prevent spurious interrupts due to noise. Setting ACKK does not affect subsequent transitions on the keyboard interrupt pins. A falling edge that occurs after writing to the ACKK bit latches another interrupt request. If the keyboard interrupt mask bit, IMASKK, is clear, the CPU loads the program counter with the vector address at locations \$FFE0 and \$FFE1.
- Return of all enabled keyboard interrupt pins to logic 1 — As long as any enabled keyboard interrupt pin is at logic 0, the keyboard interrupt remains set.

The vector fetch or software clear and the return of all enabled keyboard interrupt pins to logic 1 may occur in any order.

If the MODEK bit is clear, the keyboard interrupt pin is falling-edge-sensitive only. With MODEK clear, a vector fetch or software clear immediately clears the keyboard interrupt request.

Reset clears the keyboard interrupt request and the MODEK bit, clearing the interrupt request even if a keyboard interrupt pin stays at logic 0.

The keyboard flag bit (KEYF) in the keyboard status and control register can be used to see if a pending interrupt exists. The KEYF bit is not affected by the keyboard interrupt mask bit (IMASKK) which makes it useful in applications where polling is preferred.

To determine the logic level on a keyboard interrupt pin, disable the pull-up device, use the data direction register to configure the pin as an input and then read the data register.

NOTE: *Setting a keyboard interrupt enable bit (KBIE_x) forces the corresponding keyboard interrupt pin to be an input, overriding the data direction register. However, the data direction register bit must be a logic 0 for software to read the pin.*

14.4.1 Keyboard Initialization

When a keyboard interrupt pin is enabled, it takes time for the internal pull-up to reach a logic 1. Therefore a false interrupt can occur as soon as the pin is enabled.

To prevent a false interrupt on keyboard initialization:

1. Mask keyboard interrupts by setting the IMASKK bit in the keyboard status and control register.
2. Enable the KBI pins by setting the appropriate KBIE_x bits in the keyboard interrupt enable register.
3. Write to the ACKK bit in the keyboard status and control register to clear any false interrupts.
4. Clear the IMASKK bit.

An interrupt signal on an edge-triggered pin can be acknowledged immediately after enabling the pin. An interrupt signal on an edge- and

level-triggered interrupt pin must be acknowledged after a delay that depends on the external load.

Another way to avoid a false interrupt:

1. Configure the keyboard pins as outputs by setting the appropriate DDRA bits in the data direction register A.
2. Write logic 1s to the appropriate port A data register bits.
3. Enable the KBI pins by setting the appropriate KBIEx bits in the keyboard interrupt enable register.

14.4.2 Keyboard Status and Control Register

- Flags keyboard interrupt requests.
- Acknowledges keyboard interrupt requests.
- Masks keyboard interrupt requests.
- Controls keyboard interrupt triggering sensitivity.

Address: \$001A

	Bit 7	6	5	4	3	2	1	Bit 0
Read:	0	0	0	0	KEYF	0	IMASKK	MODEK
Write:						ACKK		
Reset:	0	0	0	0	0	0	0	0

 = Unimplemented

Figure 14-3. Keyboard Status and Control Register (KBSCR)

Bits 7–4 — Not used

These read-only bits always read as logic 0s.

KEYF — Keyboard Flag Bit

This read-only bit is set when a keyboard interrupt is pending on port-A. Reset clears the KEYF bit.

1 = Keyboard interrupt pending

0 = No keyboard interrupt pending

ACKK — Keyboard Acknowledge Bit

Writing a logic 1 to this write-only bit clears the keyboard interrupt request on port-A. ACKK always reads as logic 0. Reset clears ACKK.

IMASKK— Keyboard Interrupt Mask Bit

Writing a logic 1 to this read/write bit prevents the output of the keyboard interrupt mask from generating interrupt requests on port-A. Reset clears the IMASKK bit.

- 1 = Keyboard interrupt requests masked
- 0 = Keyboard interrupt requests not masked

MODEK — Keyboard Triggering Sensitivity Bit

This read/write bit controls the triggering sensitivity of the keyboard interrupt pins on port-A. Reset clears MODEK.

- 1 = Keyboard interrupt requests on falling edges and low levels
- 0 = Keyboard interrupt requests on falling edges only

14.4.3 Keyboard Interrupt Enable Register

The port-A keyboard interrupt enable register enables or disables each port-A pin to operate as a keyboard interrupt pin.

Address: \$001B

	Bit 7	6	5	4	3	2	1	Bit 0
Read:	0	KBIE6	KBIE5	KBIE4	KBIE3	KBIE2	KBIE1	KBIE0
Write:								
Reset:	0	0	0	0	0	0	0	0

Figure 14-4. Keyboard Interrupt Enable Register (KBIER)

KBIE6–KBIE0 — Port-A Keyboard Interrupt Enable Bits

Each of these read/write bits enables the corresponding keyboard interrupt pin on port-A to latch interrupt requests. Reset clears the keyboard interrupt enable register.

- 1 = KB x pin enabled as keyboard interrupt pin
- 0 = KB x pin not enabled as keyboard interrupt pin

14.5 Wait Mode

The keyboard modules remain active in wait mode. Clearing the IMASKK bit in the keyboard status and control register enables keyboard interrupt requests to bring the MCU out of wait mode.

14.6 Stop Mode

The keyboard module remains active in stop mode. Clearing the IMASKK bit in the keyboard status and control register enables keyboard interrupt requests to bring the MCU out of stop mode.

14.7 Keyboard Module During Break Interrupts

The system integration module (SIM) controls whether the keyboard interrupt latch can be cleared during the break state. The BCFE bit in the break flag control register (BFCR) enables software to clear status bits during the break state.

To allow software to clear the keyboard interrupt latch during a break interrupt, write a logic 1 to the BCFE bit. If a latch is cleared during the break state, it remains cleared when the MCU exits the break state.

To protect the latch during the break state, write a logic 0 to the BCFE bit. With BCFE at logic 0 (its default state), writing to the keyboard acknowledge bit (ACKK) in the keyboard status and control register during the break state has no effect.



EEPW 电子产品世界
.com.cn

Section 15. Computer Operating Properly (COP)

15.1 Contents

15.2	Introduction	163
15.3	Functional Description	164
15.4	I/O Signals	165
15.4.1	2OSCOU	165
15.4.2	COPCTL Write	165
15.4.3	Power-On Reset	165
15.4.4	Internal Reset	165
15.4.5	Reset Vector Fetch	166
15.4.6	COPD (COP Disable)	166
15.4.7	COPRS (COP Rate Select)	166
15.5	COP Control Register	167
15.6	Interrupts	167
15.7	Monitor Mode	167
15.8	Low-Power Modes	167
15.8.1	Wait Mode	167
15.8.2	Stop Mode	168
15.9	COP Module During Break Mode	168

15.2 Introduction

The computer operating properly (COP) module contains a free-running counter that generates a reset if allowed to overflow. The COP module helps software recover from runaway code. Prevent a COP reset by clearing the COP counter periodically. The COP module can be disabled through the COPD bit in the CONFIG1 register.

15.3 Functional Description

Figure 15-1 shows the structure of the COP module.

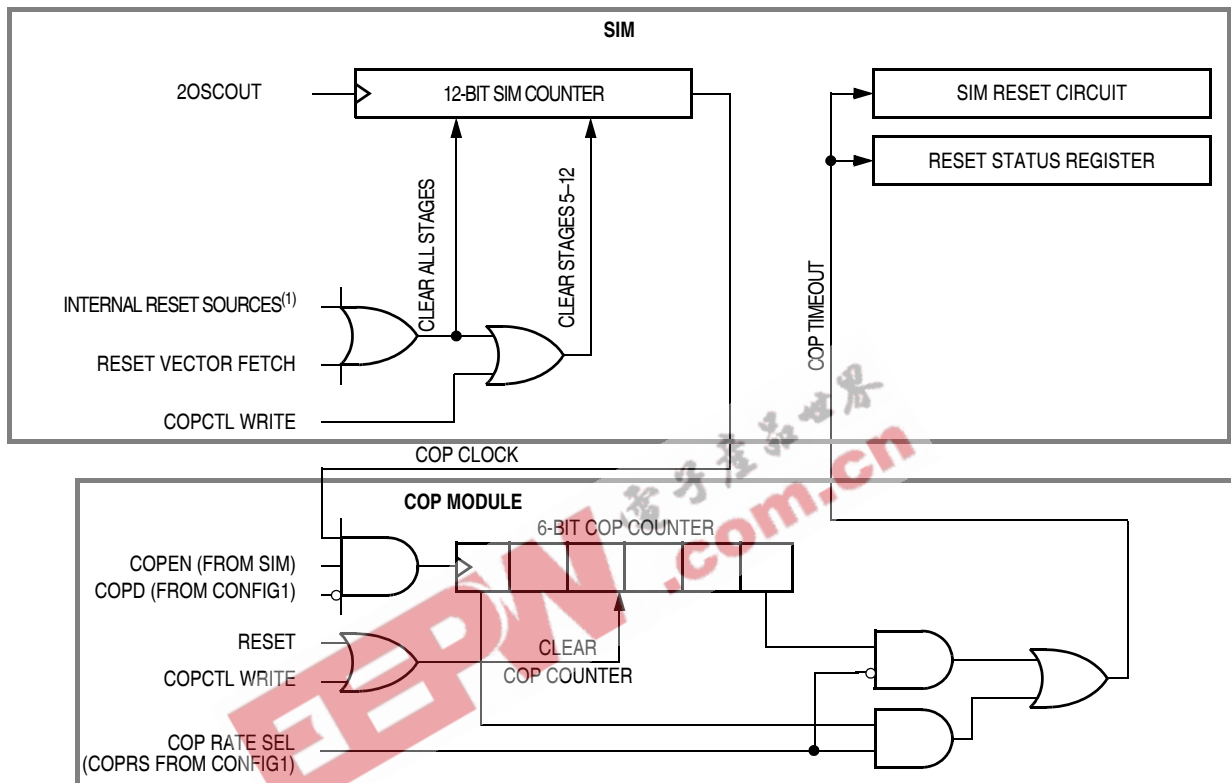

NOTE:

1. See SIM section for more details.

Figure 15-1. COP Block Diagram

The COP counter is a free-running 6-bit counter preceded by the 12-bit system integration module (SIM) counter. If not cleared by software, the COP counter overflows and generates an asynchronous reset after $2^{18} - 2^4$ or $2^{13} - 2^4$ 2OSCOU cycles; depending on the state of the COP rate select bit, COPRS, in configuration register 1. With a $2^{18} - 2^4$ 2OSCOU cycle overflow option, a 8MHz crystal gives a COP timeout period of 32.766 ms. Writing any value to location \$FFFF before an overflow occurs prevents a COP reset by clearing the COP counter and stages 12 through 5 of the SIM counter.

NOTE: Service the COP immediately after reset and before entering or after exiting stop mode to guarantee the maximum time before the first COP counter overflow.

A COP reset pulls the $\overline{\text{RST}}$ pin low for $32 \times 2\text{OSCOU}$ cycles and sets the COP bit in the reset status register (RSR). (See [7.8.2 Reset Status Register \(RSR\)](#)).

NOTE: Place COP clearing instructions in the main program and not in an interrupt subroutine. Such an interrupt subroutine could keep the COP from generating a reset even while the main program is not working properly.

15.4 I/O Signals

The following paragraphs describe the signals shown in [Figure 15-1](#).

15.4.1 2OSCOU

2OSCOU is the oscillator output signal. 2OSCOU frequency is equal to the crystal frequency or the RC-oscillator frequency.

15.4.2 COPCTL Write

Writing any value to the COP control register (COPCTL) (see [15.5 COP Control Register](#)) clears the COP counter and clears bits 12 through 5 of the SIM counter. Reading the COP control register returns the low byte of the reset vector.

15.4.3 Power-On Reset

The power-on reset (POR) circuit in the SIM clears the SIM counter $4096 \times 2\text{OSCOU}$ cycles after power-up.

15.4.4 Internal Reset

An internal reset clears the SIM counter and the COP counter.

15.4.5 Reset Vector Fetch

A reset vector fetch occurs when the vector address appears on the data bus. A reset vector fetch clears the SIM counter.

15.4.6 COPD (COP Disable)

The COPD signal reflects the state of the COP disable bit (COPD) in the configuration register (CONFIG). (See [Section 5. Configuration Register \(CONFIG\)](#).)

15.4.7 COPRS (COP Rate Select)

The COPRS signal reflects the state of the COP rate select bit (COPRS) in the configuration register 1.

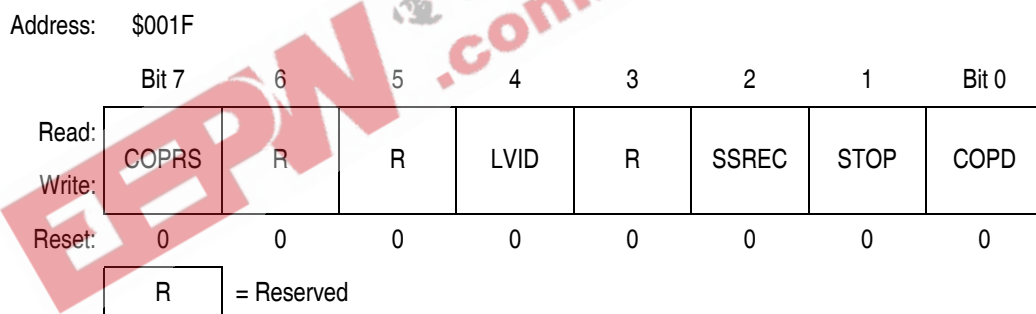

Figure 15-2. Configuration Register 1 (CONFIG1)

COPRS — COP Rate Select Bit

COPRS selects the COP timeout period. Reset clears COPRS.

1 = COP timeout period is $(2^{13} - 2^4) \times 2\text{OSCOU}\text{T}$ cycles

0 = COP timeout period is $(2^{18} - 2^4) \times 2\text{OSCOU}\text{T}$ cycles

COPD — COP Disable Bit

COPD disables the COP module.

1 = COP module disabled

0 = COP module enabled

15.5 COP Control Register

The COP control register is located at address \$FFFF and overlaps the reset vector. Writing any value to \$FFFF clears the COP counter and starts a new timeout period. Reading location \$FFFF returns the low byte of the reset vector.

Address: \$FFFF

	Bit 7	6	5	4	3	2	1	Bit 0
Read:	Low byte of reset vector							
Write:	Clear COP counter							
Reset:	Unaffected by reset							

Figure 15-3. COP Control Register (COPCTL)

15.6 Interrupts

The COP does not generate CPU interrupt requests.

15.7 Monitor Mode

The COP is disabled in monitor mode when $V_{DD} + V_{HI}$ is present on the $\overline{IRQ1}$ pin or on the \overline{RST} pin.

15.8 Low-Power Modes

The WAIT and STOP instructions put the MCU in low-power consumption standby modes.

15.8.1 Wait Mode

The COP continues to operate during wait mode. To prevent a COP reset during wait mode, periodically clear the COP counter in a CPU interrupt routine.

15.8.2 Stop Mode

Stop mode turns off the 2OSCO_{UT} input to the COP and clears the SIM counter. Service the COP immediately before entering or after exiting stop mode to ensure a full COP timeout period after entering or exiting stop mode.

15.9 COP Module During Break Mode

The COP is disabled during a break interrupt when $V_{DD} + V_{HI}$ is present on the \overline{RST} pin.

EEPW 电子產品世界
.com.cn

Section 16. Low Voltage Inhibit (LVI)

16.1 Contents

16.2	Introduction	169
16.3	Features	169
16.4	Functional Description	170
16.5	LVI Control Register (CONFIG2/CONFIG1)	170
16.6	Low-Power Modes	171
16.6.1	Wait Mode	171
16.6.2	Stop Mode	171

16.2 Introduction

This section describes the low-voltage inhibit module (LVI), which monitors the voltage on the V_{DD} pin and generates a reset when the V_{DD} voltage falls to the LVI trip (LVI_{TRIP}) voltage.

16.3 Features

Features of the LVI module include the following:

- Selectable LVI trip voltage
- Selectable LVI circuit disable

16.4 Functional Description

Figure 16-1 shows the structure of the LVI module. The LVI is enabled after a reset. The LVI module contains a bandgap reference circuit and comparator. Setting LVI disable bit (LVID) disables the LVI to monitor V_{DD} voltage. The LVI trip voltage selection bits (LVIT1, LVIT0) determines at which V_{DD} level the LVI module should take actions.

The LVI module generates one output signal:

LVI Reset — an reset signal will be generated to reset the CPU when V_{DD} drops to below the set trip point.

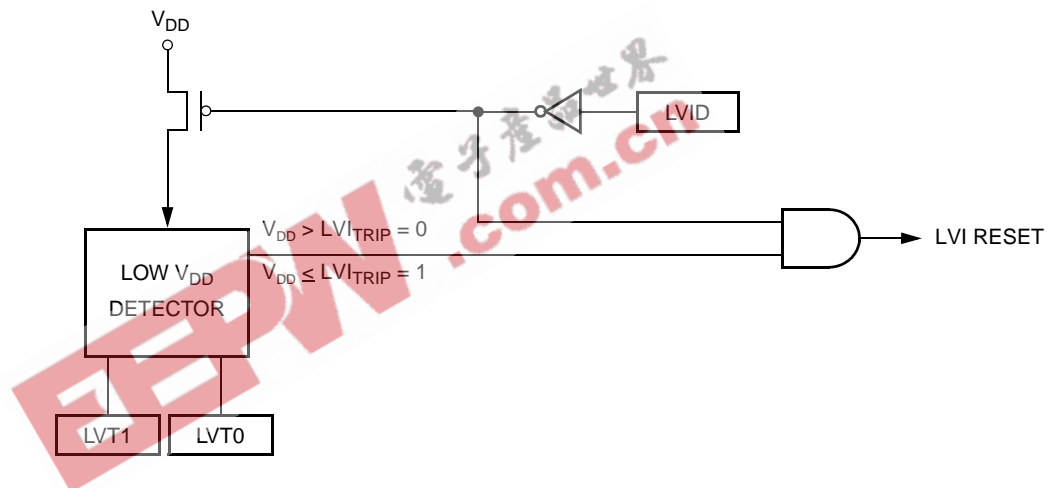

Figure 16-1. LVI Module Block Diagram

16.5 LVI Control Register (CONFIG2/CONFIG1)

Address: \$001E

	Bit 7	6	5	4	3	2	1	Bit 0
Read:	IRQPUD	R	R	LVIT1	LVIT0	R	R	R
Write:								
Reset:	0	0	0	Not affected	Not affected	0	0	0
POR:	0	0	0	0	0	0	0	0

R = Reserved

Figure 16-2. Configuration Register 2 (CONFIG2)

Address: \$001F

	Bit 7	6	5	4	3	2	1	Bit 0
Read:	COPRS	R	R	LVID	R	SSREC	STOP	COPD
Write:								
Reset:	0	0	0	0	0	0	0	0

R = Reserved

Figure 16-3. Configuration Register 1 (CONFIG1)

LVID — Low Voltage Inhibit Disable Bit

1 = Low voltage inhibit disabled

0 = Low voltage inhibit enabled

LVIT1, LVIT0 — LVI Trip Voltage Selection

These two bits determine at which level of V_{DD} the LVI module will come into action. LVIT1 and LVIT0 are cleared by a Power-On Reset only.

LVIT1	LVIT0	Trip Voltage ⁽¹⁾	Comments
0	0	V_{LVR3} (2.4V)	For $V_{DD}=3V$ operation
0	1	V_{LVR3} (2.4V)	For $V_{DD}=3V$ operation
1	0	V_{LVR5} (4.0V)	For $V_{DD}=5V$ operation
1	1	Reserved	

1. See [Section 18. Electrical Specifications](#) for full parameters.

16.6 Low-Power Modes

The STOP and WAIT instructions put the MCU in low-power-consumption standby modes.

16.6.1 Wait Mode

The LVI module, when enabled, will continue to operate in WAIT Mode.

16.6.2 Stop Mode

The LVI module, when enabled, will continue to operate in STOP Mode.



EEPW 电子产品世界
.com.cn

Section 17. Break Module (BREAK)

17.1 Contents

17.2	Introduction	173
17.3	Features	174
17.4	Functional Description	174
17.4.1	Flag Protection During Break Interrupts	176
17.4.2	CPU During Break Interrupts	176
17.4.3	TIM During Break Interrupts	176
17.4.4	COP During Break Interrupts	176
17.5	Break Module Registers	176
17.5.1	Break Status and Control Register (BRKSCR)	177
17.5.2	Break Address Registers	178
17.5.3	Break Status Register	178
17.5.4	Break Flag Control Register (BFCR)	180
17.6	Low-Power Modes	180
17.6.1	Wait Mode	180
17.6.2	Stop Mode	180

17.2 Introduction

This section describes the break module. The break module can generate a break interrupt that stops normal program flow at a defined address to enter a background program.

17.3 Features

Features of the break module include the following:

- Accessible I/O registers during the break Interrupt
- CPU-generated break interrupts
- Software-generated break interrupts
- COP disabling during break interrupts

17.4 Functional Description

When the internal address bus matches the value written in the break address registers, the break module issues a breakpoint signal ($\overline{\text{BKPT}}$) to the SIM. The SIM then causes the CPU to load the instruction register with a software interrupt instruction (SWI) after completion of the current CPU instruction. The program counter vectors to \$FFFC and \$FFFD (\$FEFC and \$FEFD in monitor mode).

The following events can cause a break interrupt to occur:

- A CPU-generated address (the address in the program counter) matches the contents of the break address registers.
- Software writes a logic one to the BRKA bit in the break status and control register.

When a CPU generated address matches the contents of the break address registers, the break interrupt begins after the CPU completes its current instruction. A return from interrupt instruction (RTI) in the break routine ends the break interrupt and returns the MCU to normal operation. [Figure 17-1](#) shows the structure of the break module.

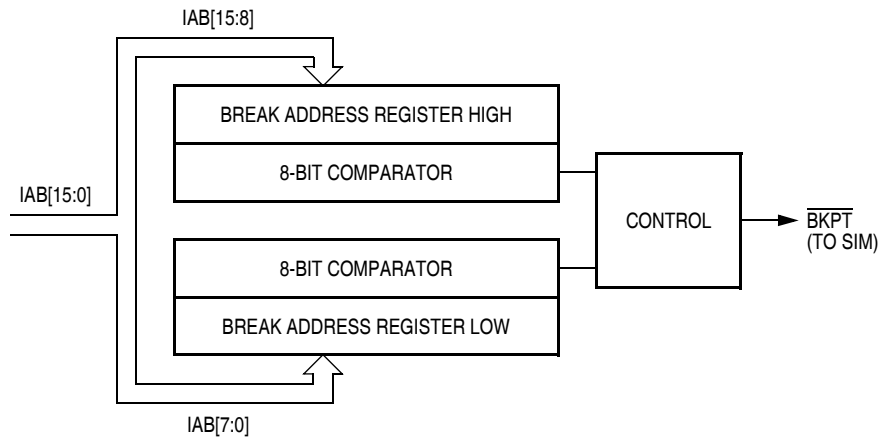

Figure 17-1. Break Module Block Diagram

Addr.	Register Name	Bit 7	6	5	4	3	2	1	Bit 0	
\$FE00	Break Status Register (BSR)	Read:	R	R	R	R	R	SBSW	R	
		Write:						See note		
		Reset:	0							
\$FE03	Break Flag Control Register (BFCR)	Read:	BCFE	R	R	R	R	R	R	
		Write:								
		Reset:	0							
\$FE0C	Break Address High Register (BRKH)	Read:	Bit15	Bit14	Bit13	Bit12	Bit11	Bit10	Bit9	Bit8
		Write:								
		Reset:	0	0	0	0	0	0	0	0
\$FE0D	Break Address low Register (BRKL)	Read:	Bit7	Bit6	Bit5	Bit4	Bit3	Bit2	Bit1	Bit0
		Write:								
		Reset:	0	0	0	0	0	0	0	0
\$FE0E	Break Status and Control Register (BRKSCR)	Read:	BRKE	BRKA	0	0	0	0	0	0
		Write:								
		Reset:	0	0	0	0	0	0	0	0

Note: Writing a logic 0 clears SBSW. = Unimplemented = Reserved

Figure 17-2. Break I/O Register Summary

17.4.1 Flag Protection During Break Interrupts

The system integration module (SIM) controls whether or not module status bits can be cleared during the break state. The BCFE bit in the break flag control register (BFCR) enables software to clear status bits during the break state. (See [7.8.3 Break Flag Control Register \(BFCR\)](#) and see the Break Interrupts subsection for each module.)

17.4.2 CPU During Break Interrupts

The CPU starts a break interrupt by:

- Loading the instruction register with the SWI instruction
- Loading the program counter with \$FEFC:\$FFFD (\$FEFC:\$FEFD in monitor mode)

The break interrupt begins after completion of the CPU instruction in progress. If the break address register match occurs on the last cycle of a CPU instruction, the break interrupt begins immediately.

17.4.3 TIM During Break Interrupts

A break interrupt stops the timer counter.

17.4.4 COP During Break Interrupts

The COP is disabled during a break interrupt when $V_{DD} + V_{HI}$ is present on the \overline{RST} pin.

17.5 Break Module Registers

These registers control and monitor operation of the break module:

- Break status and control register (BRKSCR)
- Break address register high (BRKH)
- Break address register low (BRKL)
- Break status register (BSR)
- Break flag control register (BFCR)

17.5.1 Break Status and Control Register (BRKSCR)

The break status and control register contains break module enable and status bits.

Address: \$FE0E

	Bit 7	6	5	4	3	2	1	Bit 0
Read:	BRKE	BRKA	0	0	0	0	0	0
Write:								
Reset:	0	0	0	0	0	0	0	0

= Unimplemented

Figure 17-3. Break Status and Control Register (BRKSCR)

BRKE — Break Enable Bit

This read/write bit enables breaks on break address register matches. Clear BRKE by writing a logic zero to bit 7. Reset clears the BRKE bit.

1 = Breaks enabled on 16-bit address match

0 = Breaks disabled

BRKA — Break Active Bit

This read/write status and control bit is set when a break address match occurs. Writing a logic one to BRKA generates a break interrupt. Clear BRKA by writing a logic zero to it before exiting the break routine. Reset clears the BRKA bit.

1 = Break address match

0 = No break address match

17.5.2 Break Address Registers

The break address registers contain the high and low bytes of the desired breakpoint address. Reset clears the break address registers.

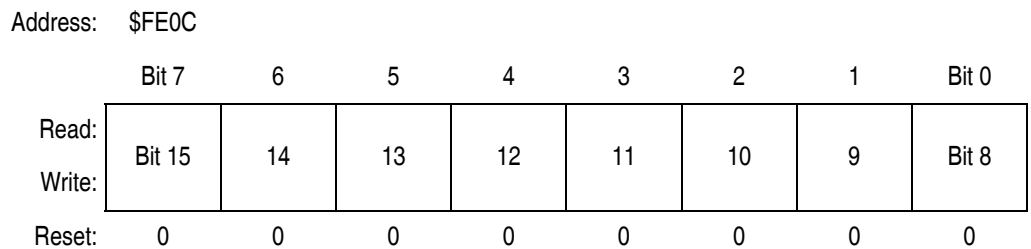

Figure 17-4. Break Address Register High (BRKH)

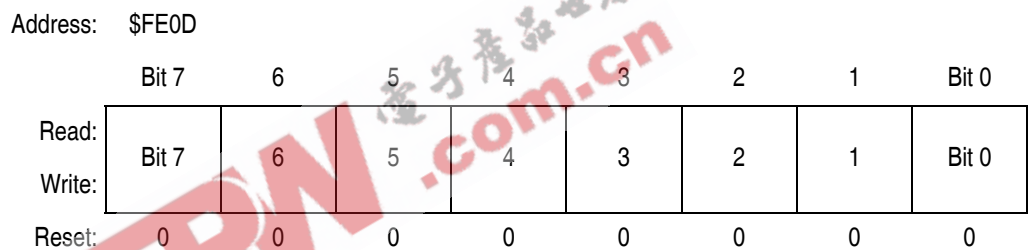

Figure 17-5. Break Address Register Low (BRKL)

17.5.3 Break Status Register

The break status register contains a flag to indicate that a break caused an exit from stop or wait mode.

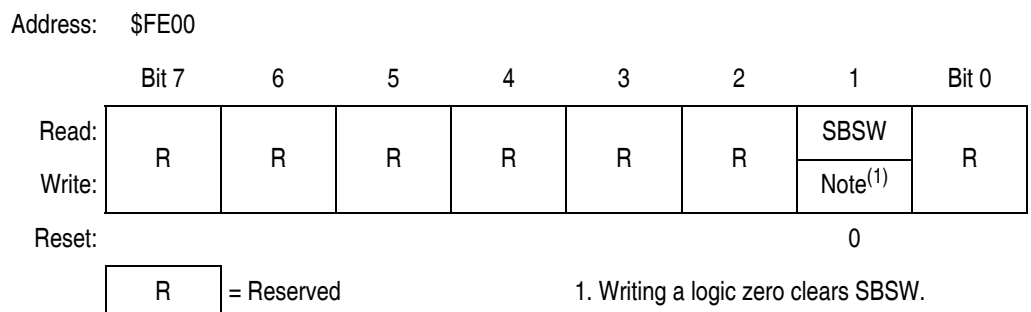

Figure 17-6. Break Status Register (BSR)

SBSW — SIM Break Stop/Wait

This status bit is useful in applications requiring a return to wait or stop mode after exiting from a break interrupt. Clear SBSW by writing a logic zero to it. Reset clears SBSW.

1 = Stop mode or wait mode was exited by break interrupt

0 = Stop mode or wait mode was not exited by break interrupt

SBSW can be read within the break state SWI routine. The user can modify the return address on the stack by subtracting one from it. The following code is an example of this. Writing zero to the SBSW bit clears it.

```
; This code works if the H register has been pushed onto the stack in the break
; service routine software. This code should be executed at the end of the
; break service routine software.

HIBYTE EQU 5
LOBYTE EQU 6

; If not SBSW, do RTI
BRCLR SBSW,BSR, RETURN ; See if wait mode or stop mode was exited
; by break.

TST LOBYTE,SP ; If RETURNLO is not zero,
BNE DOLO ; then just decrement low byte.
DEC HIBYTE,SP ; Else deal with high byte, too.
DOLO DEC LOBYTE,SP ; Point to WAIT/STOP opcode.
RETURN PULH ; Restore H register.
RTI
```

17.5.4 Break Flag Control Register (BFCR)

The break control register contains a bit that enables software to clear status bits while the MCU is in a break state.

Address: \$FE03

	Bit 7	6	5	4	3	2	1	Bit 0
Read:	BCFE	R	R	R	R	R	R	R
Write:	BCFE	R	R	R	R	R	R	R
Reset:	0							

R

 = Reserved

Figure 17-7. Break Flag Control Register (BFCR)

BCFE — Break Clear Flag Enable Bit

This read/write bit enables software to clear status bits by accessing status registers while the MCU is in a break state. To clear status bits during the break state, the BCFE bit must be set.

1 = Status bits clearable during break

0 = Status bits not clearable during break

17.6 Low-Power Modes

The WAIT and STOP instructions put the MCU in low-power-consumption standby modes.

17.6.1 Wait Mode

If enabled, the break module is active in wait mode. In the break routine, the user can subtract one from the return address on the stack if SBSW is set (see [7.7 Low-Power Modes](#)). Clear the SBSW bit by writing logic zero to it.

17.6.2 Stop Mode

A break interrupt causes exit from stop mode and sets the SBSW bit in the break status register. See [7.8 SIM Registers](#).

Section 18. Electrical Specifications

18.1 Contents

18.2	Introduction	181
18.3	Absolute Maximum Ratings	182
18.4	Functional Operating Range	183
18.5	Thermal Characteristics	183
18.6	5V DC Electrical Characteristics	184
18.7	5V Control Timing	185
18.8	5V Oscillator Characteristics	186
18.9	3V DC Electrical Characteristics	187
18.10	3V Control Timing	188
18.11	3V Oscillator Characteristics	189
18.12	Typical Supply Currents	190
18.13	ADC Characteristics	191

18.2 Introduction

This section contains electrical and timing specifications.

18.3 Absolute Maximum Ratings

Maximum ratings are the extreme limits to which the MCU can be exposed without permanently damaging it.

NOTE: *This device is not guaranteed to operate properly at the maximum ratings. Refer to Sections 18.6 and 18.9 for guaranteed operating conditions.*

Table 18-1. Absolute Maximum Ratings⁽¹⁾

Characteristic	Symbol	Value	Unit
Supply voltage	V_{DD}	-0.3 to +6.0	V
Input voltage	V_{IN}	$V_{SS}-0.3$ to $V_{DD}+0.3$	V
Mode entry voltage, $\overline{IRQ1}$ pin	$V_{DD}+V_{HI}$	$V_{SS}-0.3$ to +8.5	V
Maximum current per pin excluding V_{DD} and V_{SS}	I	±25	mA
Storage temperature	T_{STG}	-55 to +150	°C
Maximum current out of V_{SS}	I_{MVSS}	100	mA
Maximum current into V_{DD}	I_{MVDD}	100	mA

NOTE:

1. Voltages referenced to V_{SS} .

NOTE: *This device contains circuitry to protect the inputs against damage due to high static voltages or electric fields; however, it is advised that normal precautions be taken to avoid application of any voltage higher than maximum-rated voltages to this high-impedance circuit. For proper operation, it is recommended that V_{IN} and V_{OUT} be constrained to the range $V_{SS} \leq (V_{IN} \text{ or } V_{OUT}) \leq V_{DD}$. Reliability of operation is enhanced if unused inputs are connected to an appropriate logic voltage level (for example, either V_{SS} or V_{DD} .)*

18.4 Functional Operating Range

Table 18-2. Operating Range

Characteristic	Symbol	Value		Unit
Operating temperature range	T_A	-40 to +125	-40 to +85	°C
Operating voltage range	V_{DD}	5V ± 10%	3V ± 10%	V

18.5 Thermal Characteristics

Table 18-3. Thermal Characteristics

Characteristic	Symbol	Value	Unit
Thermal resistance	θ_{JA}		
20-Pin PDIP		70	°C/W
20-Pin SOIC		70	°C/W
28-Pin PDIP		70	°C/W
28-Pin SOIC		70	°C/W
I/O pin power dissipation	$P_{I/O}$	User determined	W
Power dissipation ⁽¹⁾	P_D	$P_D = (I_{DD} \times V_{DD}) + P_{I/O} = K/(T_J + 273 \text{ }^\circ\text{C})$	W
Constant ⁽²⁾	K	$P_D \times (T_A + 273 \text{ }^\circ\text{C}) + P_D^2 \times \theta_{JA}$	W/°C
Average junction temperature	T_J	$T_A + (P_D \times \theta_{JA})$	°C
Maximum junction temperature	T_{JM}	100	°C

NOTES:

1. Power dissipation is a function of temperature.
2. K constant unique to the device. K can be determined for a known T_A and measured P_D . With this value of K, P_D and T_J can be determined for any value of T_A .

18.6 5V DC Electrical Characteristics

Table 18-4. DC Electrical Characteristics (5V)

Characteristic ⁽¹⁾	Symbol	Min	Typ ⁽²⁾	Max	Unit
Output high voltage ($I_{LOAD} = -2.0\text{mA}$) PTA0–PTA6, PTB0–PTB7, PTD0–PTD7	V_{OH}	$V_{DD}-0.8$	—	—	V
Output low voltage ($I_{LOAD} = 1.6\text{mA}$) PTA6, PTB0–PTB7, PTD0, PTD1, PTD4, PTD5	V_{OL}	—	—	0.4	V
Output low voltage ($I_{LOAD} = 25\text{mA}$) PTD6, PTD7	V_{OL}	—	—	0.5	V
LED drives ($V_{OL} = 3\text{V}$) PTA0–PTA5, PTD2, PTD3, PTD6, PTD7	I_{OL}	10	19	25	mA
Input high voltage PTA0–PTA6, PTB0–PTB7, PTD0–PTD7, \overline{RST} , $\overline{IRQ1}$, OSC1	V_{IH}	$0.7 \times V_{DD}$	—	V_{DD}	V
Input low voltage PTA0–PTA6, PTB0–PTB7, PTD0–PTD7, \overline{RST} , $\overline{IRQ1}$, OSC1	V_{IL}	V_{SS}	—	$0.3 \times V_{DD}$	V
V_{DD} supply current Run, $f_{OP} = 4\text{MHz}$ ⁽³⁾ Wait (MC68HRC08xxx) ⁽⁴⁾ Wait (MC68HC08xxx) ⁽⁴⁾ Stop ⁽⁵⁾ -40°C to 85°C	I_{DD}	—	10 1 5 1	12 1.5 5.5 5	mA mA mA μA
Digital I/O ports Hi-Z leakage current	I_{IL}	—	—	± 10	μA
Input current	I_{IN}	—	—	± 1	μA
Capacitance Ports (as input or output)	C_{OUT} C_{IN}	— —	— —	12 8	pF
POR rearm voltage ⁽⁶⁾	V_{POR}	0	—	100	mV
POR rise time ramp rate ⁽⁷⁾	R_{POR}	0.035	—	—	V/ms
Monitor mode entry voltage	$V_{DD}+V_{HI}$	$1.5 \times V_{DD}$	—	8.5	V
Pullup resistors ⁽⁸⁾ PTD6, PTD7 \overline{RST} , $\overline{IRQ1}$, PTA0–PTA6	R_{PU1} R_{PU2}	1.8 16	3.3 26	4.8 36	k Ω k Ω
LVI reset voltage	V_{LVR5}	3.6	4.0	4.4	V

Table 18-4. DC Electrical Characteristics (5V)

Characteristic ⁽¹⁾	Symbol	Min	Typ ⁽²⁾	Max	Unit
-------------------------------	--------	-----	--------------------	-----	------

NOTES:

1. $V_{DD} = 4.5$ to 5.5 Vdc, $V_{SS} = 0$ Vdc, $T_A = T_L$ to T_H , unless otherwise noted.
2. Typical values reflect average measurements at midpoint of voltage range, $25\text{ }^\circ\text{C}$ only.
3. Run (operating) I_{DD} measured using external square wave clock source. All inputs 0.2 V from rail. No dc loads. Less than 100 pF on all outputs. $C_L = 20$ pF on OSC2. All ports configured as inputs. OSC2 capacitance linearly affects run I_{DD} . Measured with all modules enabled.
4. Wait I_{DD} measured using external square wave clock source ($f_{OP} = 4$ MHz); all inputs 0.2 V from rail; no dc loads; less than 100 pF on all outputs. $C_L = 20$ pF on OSC2; all ports configured as inputs; OSC2 capacitance linearly affects wait I_{DD} .
5. STOP I_{DD} measured with OSC1 grounded, no port pins sourcing current. LVI is disabled.
6. Maximum is highest voltage that POR is guaranteed.
7. If minimum V_{DD} is not reached before the internal POR reset is released, \overline{RST} must be driven low externally until minimum V_{DD} is reached.
8. R_{PU1} and R_{PU2} are measured at $V_{DD} = 5.0$ V

18.7 5V Control Timing

Table 18-5. Control Timing (5V)

Characteristic ⁽¹⁾	Symbol	Min	Max	Unit
Internal operating frequency ⁽²⁾	f_{OP}	—	8	MHz
\overline{RST} input pulse width low ⁽³⁾	t_{IRL}	750	—	ns

NOTES:

1. $V_{DD} = 4.5$ to 5.5 Vdc, $V_{SS} = 0$ Vdc, $T_A = T_L$ to T_H ; timing shown with respect to 20% V_{DD} and 70% V_{SS} , unless otherwise noted.
2. Some modules may require a minimum frequency greater than dc for proper operation; see appropriate table for this information.
3. Minimum pulse width reset is guaranteed to be recognized. It is possible for a smaller pulse width to cause a reset.

18.8 5V Oscillator Characteristics

Table 18-6. Oscillator Component Specifications (5V)

Characteristic	Symbol	Min	Typ	Max	Unit
Crystal frequency, XTALCLK	f_{OSCCLK}	—	10	32	MHz
RC oscillator frequency, RCCLK	f_{RCCLK}	2	10	12	MHz
External clock reference frequency ⁽¹⁾	f_{OSCCLK}	dc	—	32	MHz
Crystal load capacitance ⁽²⁾	C_L	—	—	—	
Crystal fixed capacitance ⁽²⁾	C_1	—	$2 \times C_L$	—	
Crystal tuning capacitance ⁽²⁾	C_2	—	$2 \times C_L$	—	
Feedback bias resistor	R_B	—	10 M Ω	—	
Series resistor ^{(2), (3)}	R_S	—	—	—	
RC oscillator external R	R_{EXT}	See Figure 18-1			
RC oscillator external C	C_{EXT}	—	10	—	pF

NOTES:

1. No more than 10% duty cycle deviation from 50%
2. Consult crystal vendor data sheet
3. Not Required for high frequency crystals

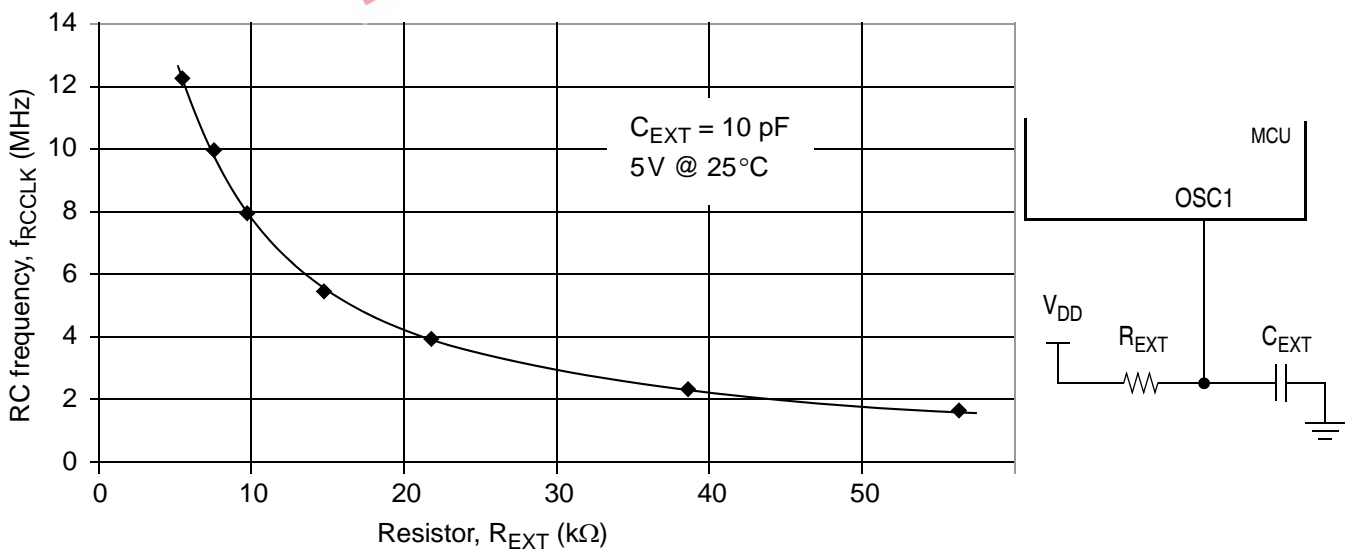

Figure 18-1. RC vs. Frequency (5V @ 25°C)

18.9 3V DC Electrical Characteristics

Table 18-7. DC Electrical Characteristics (3V)

Characteristic ⁽¹⁾	Symbol	Min	Typ ⁽²⁾	Max	Unit
Output high voltage ($I_{LOAD} = -1.0\text{mA}$) PTA0–PTA6, PTB0–PTB7, PTD0–PTD7	V_{OH}	$V_{DD} - 0.4$	—	—	V
Output low voltage ($I_{LOAD} = 0.8\text{mA}$) PTA6, PTB0–PTB7, PTD0, PTD1, PTD4, PTD5	V_{OL}	—	—	0.4	V
Output low voltage ($I_{LOAD} = 20\text{mA}$) PTD6, PTD7	V_{OL}	—	—	0.5	V
LED drives ($V_{OL} = 1.8\text{V}$) PTA0–PTA5, PTD2, PTD3, PTD6, PTD7	I_{OL}	4	9	12	mA
Input high voltage PTA0–PTA6, PTB0–PTB7, PTD0–PTD7, \overline{RST} , $\overline{IRQ1}$, OSC1	V_{IH}	$0.7 \times V_{DD}$	—	V_{DD}	V
Input low voltage PTA0–PTA6, PTB0–PTB7, PTD0–PTD7, \overline{RST} , $\overline{IRQ1}$, OSC1	V_{IL}	V_{SS}	—	$0.3 \times V_{DD}$	V
V_{DD} supply current Run, $f_{OP} = 2\text{MHz}$ ⁽³⁾ Wait (MC68HRC08xxx) ⁽⁴⁾ Wait (MC68HC08xxx) ⁽⁴⁾ Stop ⁽⁵⁾ -40°C to 85°C	I_{DD}	— — — —	5 1 4 1	8 1.3 4.5 5	mA mA mA μA
Digital I/O ports Hi-Z leakage current	I_{IL}	—	—	± 10	μA
Input current	I_{IN}	—	—	± 1	μA
Capacitance Ports (as input or output)	C_{OUT} C_{IN}	— —	— —	12 8	pF
POR rearm voltage ⁽⁶⁾	V_{POR}	0	—	100	mV
POR rise time ramp rate ⁽⁷⁾	R_{POR}	0.035	—	—	V/ms
Monitor mode entry voltage	$V_{DD} + V_{HI}$	$1.5 \times V_{DD}$	—	8.5	V
Pullup resistors ⁽⁸⁾ PTD6, PTD7 \overline{RST} , $\overline{IRQ1}$, PTA0–PTA6	R_{PU1} R_{PU2}	1.8 16	3.3 26	4.8 36	k Ω k Ω
LVI reset voltage	V_{LVR3}	2.0	2.4	2.69	V

Table 18-7. DC Electrical Characteristics (3V)

Characteristic ⁽¹⁾	Symbol	Min	Typ ⁽²⁾	Max	Unit
-------------------------------	--------	-----	--------------------	-----	------

NOTES:

1. $V_{DD} = 2.7$ to 3.3 Vdc, $V_{SS} = 0$ Vdc, $T_A = T_L$ to T_H , unless otherwise noted.
2. Typical values reflect average measurements at midpoint of voltage range, $25\text{ }^\circ\text{C}$ only.
3. Run (operating) I_{DD} measured using external square wave clock source. All inputs 0.2 V from rail. No dc loads. Less than 100 pF on all outputs. $C_L = 20$ pF on OSC2. All ports configured as inputs. OSC2 capacitance linearly affects run I_{DD} . Measured with all modules enabled.
4. Wait I_{DD} measured using external square wave clock source ($f_{OP} = 4$ MHz); all inputs 0.2 V from rail; no dc loads; less than 100 pF on all outputs. $C_L = 20$ pF on OSC2; all ports configured as inputs; OSC2 capacitance linearly affects wait I_{DD} .
5. STOP I_{DD} measured with OSC1 grounded, no port pins sourcing current. LVI is disabled.
6. Maximum is highest voltage that POR is guaranteed.
7. If minimum V_{DD} is not reached before the internal POR reset is released, \overline{RST} must be driven low externally until minimum V_{DD} is reached.
8. R_{PU1} and R_{PU2} are measured at $V_{DD} = 5.0$ V

18.10 3V Control Timing

Table 18-8. Control Timing (3V)

Characteristic ⁽¹⁾	Symbol	Min	Max	Unit
Internal operating frequency ⁽²⁾	f_{OP}	—	4	MHz
\overline{RST} input pulse width low ⁽³⁾	t_{IRL}	1.5	—	μs

NOTES:

1. $V_{DD} = 2.7$ to 3.3 Vdc, $V_{SS} = 0$ Vdc, $T_A = T_L$ to T_H ; timing shown with respect to 20% V_{DD} and 70% V_{DD} , unless otherwise noted.
2. Some modules may require a minimum frequency greater than dc for proper operation; see appropriate table for this information.
3. Minimum pulse width reset is guaranteed to be recognized. It is possible for a smaller pulse width to cause a reset.

18.11 3V Oscillator Characteristics

Table 18-9. Oscillator Component Specifications (3V)

Characteristic	Symbol	Min	Typ	Max	Unit
Crystal frequency, XTALCLK	f_{OSCCLK}	—	8	16	MHz
RC oscillator frequency, RCCLK	f_{RCCLK}	2	8	12	MHz
External clock reference frequency ⁽¹⁾	f_{OSCCLK}	dc	—	16	MHz
Crystal load capacitance ⁽²⁾	C_L	—	—	—	
Crystal fixed capacitance ⁽²⁾	C_1	—	$2 \times C_L$	—	
Crystal tuning capacitance ⁽²⁾	C_2	—	$2 \times C_L$	—	
Feedback bias resistor	R_B	—	10 M Ω	—	
Series resistor ^{(2), (3)}	R_S	—	—	—	
RC oscillator external R	R_{EXT}	See Figure 18-2			
RC oscillator external C	C_{EXT}	—	10	—	pF

NOTES:

1. No more than 10% duty cycle deviation from 50%
2. Consult crystal vendor data sheet
3. Not Required for high frequency crystals

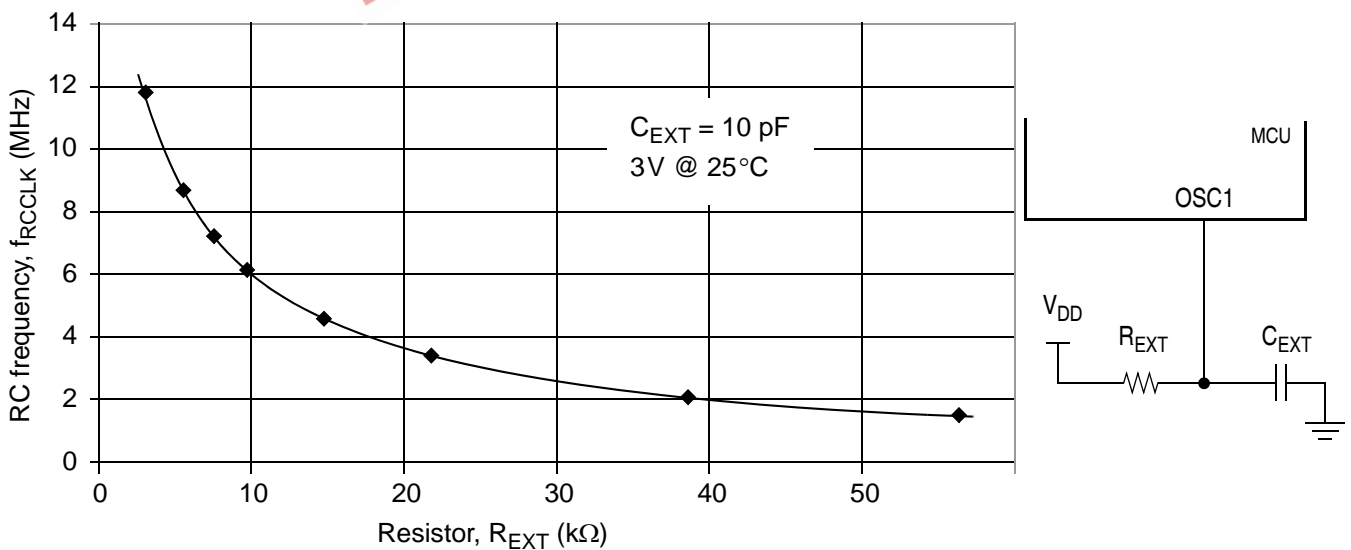

Figure 18-2. RC vs. Frequency (3V @ 25°C)

18.12 Typical Supply Currents

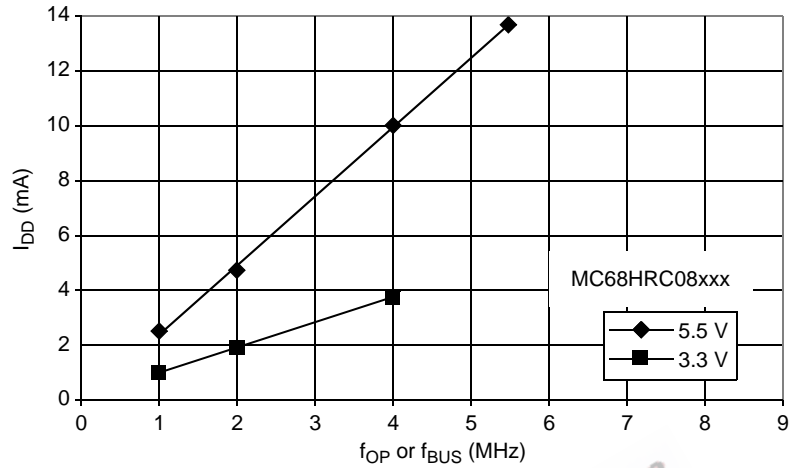

Figure 18-3. Typical Operating I_{DD} , with all Modules Turned On (25 °C)

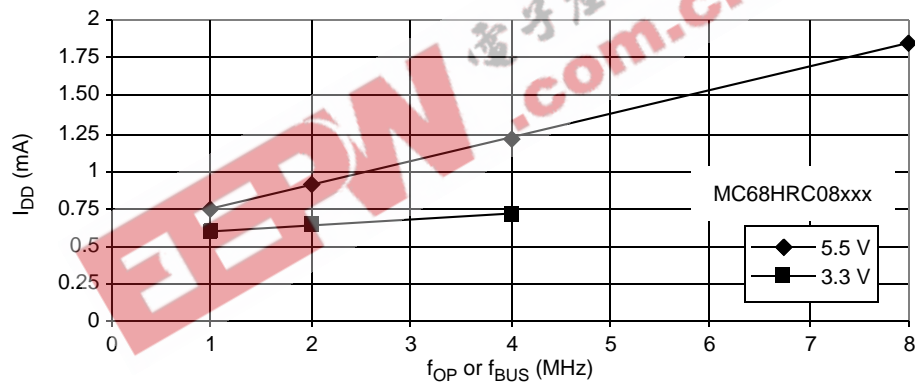

Figure 18-4. Typical Wait Mode I_{DD} , with ADC Turned On (25 °C)

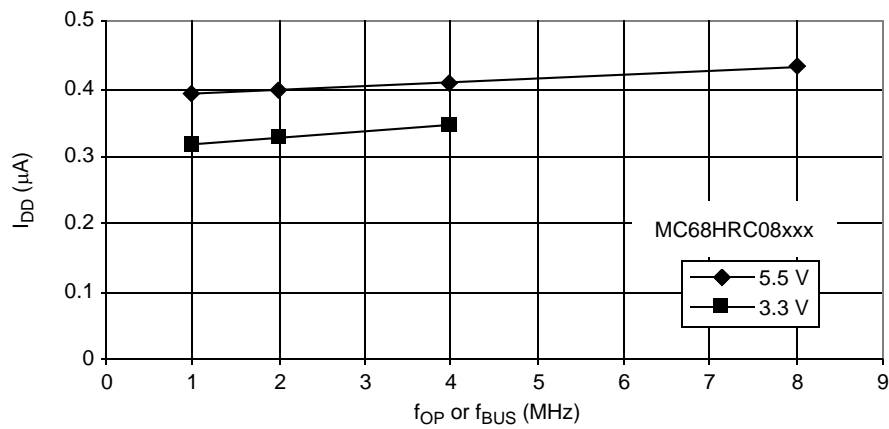

Figure 18-5. Typical Stop Mode I_{DD} , with all Modules Disabled (25 °C)

18.13 ADC Characteristics

Table 18-10. ADC Characteristics

Characteristic	Symbol	Min	Max	Unit	Comments
Supply voltage	V_{DDAD}	2.7 (V_{DD} min)	5.5 (V_{DD} max)	V	
Input voltages	V_{ADIN}	V_{SS}	V_{DD}	V	
Resolution	B_{AD}	8	8	Bits	
Absolute accuracy	A_{AD}	± 0.5	± 1.5	LSB	Includes quantization
ADC internal clock	f_{ADIC}	0.5	1.048	MHz	$t_{AIC} = 1/f_{ADIC}$; tested only at 1 MHz
Conversion range	R_{AD}	V_{SS}	V_{DD}	V	
Power-up time	t_{ADPU}	16		t_{AIC} cycles	
Conversion time	t_{ADC}	16	17	t_{AIC} cycles	
Sample time ⁽¹⁾	t_{ADS}	5	—	t_{AIC} cycles	
Zero input reading ⁽²⁾	Z_{ADI}	00	01	Hex	$V_{IN} = V_{SS}$
Full-scale reading ⁽³⁾	F_{ADI}	FE	FF	Hex	$V_{IN} = V_{DD}$
Input capacitance	C_{ADI}	—	(20) 8	pF	Not tested
Input leakage ⁽³⁾ Port B/port D	—	—	± 1	μA	

NOTES:

1. Source impedances greater than 10 k Ω adversely affect internal RC charging time during input sampling.
2. Zero-input/full-scale reading requires sufficient decoupling measures for accurate conversions.
3. The external system error caused by input leakage current is approximately equal to the product of R source and input current.



EEPW 电子产品世界
.com.cn

Section 19. Mechanical Specifications

19.1 Contents

19.2	Introduction	193
19.3	20-Pin PDIP	194
19.4	20-Pin SOIC	194
19.5	28-Pin PDIP	195
19.6	28-Pin SOIC	195

19.2 Introduction

This section gives the dimensions for:

- 20-pin plastic dual in-line package (case #738)
- 20-pin small outline integrated circuit package (case #751D)
- 28-pin plastic dual in-line package (case #710)
- 28-pin small outline integrated circuit package (case #751F)

The following figures show the latest package drawings at the time of this publication. To make sure that you have the latest package specifications, please visit the website at <http://freescale.com>. Follow Mfax or Worldwide Web on-line instructions to retrieve the current mechanical specifications.

19.3 20-Pin PDIP

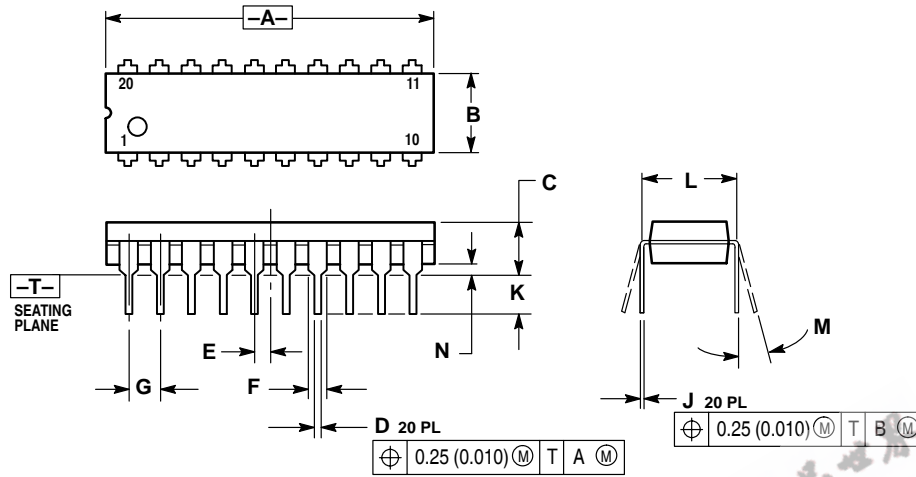

NOTES:

1. DIMENSIONING AND TOLERANCING PER ANSI Y14.5M, 1982.
2. CONTROLLING DIMENSION: INCH.
3. DIMENSION L TO CENTER OF LEAD WHEN FORMED PARALLEL.
4. DIMENSION B DOES NOT INCLUDE MOLD FLASH.

DIM	INCHES		MILLIMETERS	
	MIN	MAX	MIN	MAX
A	1.010	1.070	25.66	27.17
B	0.240	0.260	6.10	6.60
C	0.150	0.180	3.81	4.57
D	0.015	0.022	0.39	0.55
E	0.050 BSC		1.27 BSC	
F	0.050	0.070	1.27	1.77
G	0.100 BSC		2.54 BSC	
J	0.008	0.015	0.21	0.38
K	0.110	0.140	2.80	3.55
L	0.300 BSC		7.62 BSC	
M	0°	15°	0°	15°
N	0.020	0.040	0.51	1.01

Figure 19-1. 20-Pin PDIP (Case #738)

19.4 20-Pin SOIC

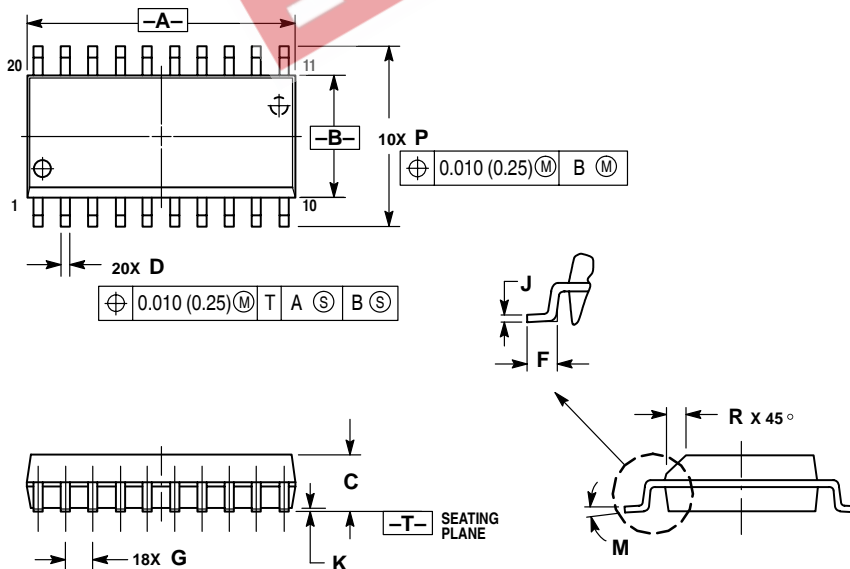

NOTES:

1. DIMENSIONING AND TOLERANCING PER ANSI Y14.5M, 1982.
2. CONTROLLING DIMENSION: MILLIMETER.
3. DIMENSIONS A AND B DO NOT INCLUDE MOLD PROTRUSION.
4. MAXIMUM MOLD PROTRUSION 0.150 (0.006) PER SIDE.
5. DIMENSION D DOES NOT INCLUDE DAMBAR PROTRUSION. ALLOWABLE DAMBAR PROTRUSION SHALL BE 0.13 (0.005) TOTAL IN EXCESS OF D DIMENSION AT MAXIMUM MATERIAL CONDITION.

DIM	MILLIMETERS		INCHES	
	MIN	MAX	MIN	MAX
A	12.65	12.95	0.499	0.510
B	7.40	7.60	0.292	0.299
C	2.35	2.65	0.093	0.104
D	0.35	0.49	0.014	0.019
F	0.50	0.90	0.020	0.035
G	1.27 BSC		0.050 BSC	
J	0.25	0.32	0.010	0.012
K	0.10	0.25	0.004	0.009
M	0°	7°	0°	7°
P	10.05	10.55	0.395	0.415
R	0.25	0.75	0.010	0.029

Figure 19-2. 20-Pin SOIC (Case #751D)

19.5 28-Pin PDIP

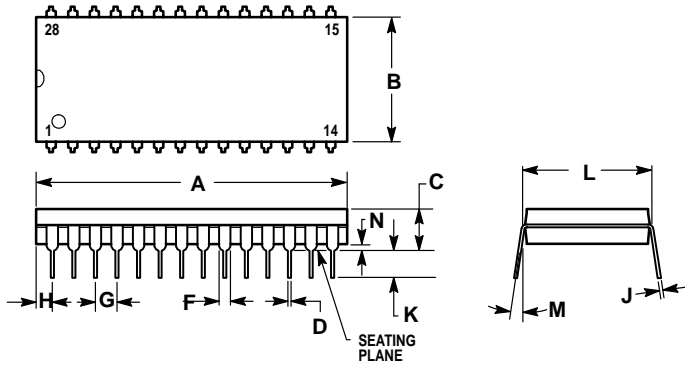

NOTES:

1. POSITIONAL TOLERANCE OF LEADS (D), SHALL BE WITHIN 0.25 (0.010) AT MAXIMUM MATERIAL CONDITION, IN RELATION TO SEATING PLANE AND EACH OTHER.
2. DIMENSION L TO CENTER OF LEADS WHEN FORMED PARALLEL.
3. DIMENSION B DOES NOT INCLUDE MOLD FLASH.

DIM	MILLIMETERS		INCHES	
	MIN	MAX	MIN	MAX
A	36.45	37.21	1.435	1.465
B	13.72	14.22	0.540	0.560
C	3.94	5.08	0.155	0.200
D	0.36	0.56	0.014	0.022
F	1.02	1.52	0.040	0.060
G	2.54 BSC		0.100 BSC	
H	1.65	2.16	0.065	0.085
J	0.20	0.38	0.008	0.015
K	2.92	3.43	0.115	0.135
L	15.24 BSC		0.600 BSC	
M	0°	15°	0°	15°
N	0.51	1.02	0.020	0.040

Figure 19-3. 28-Pin PDIP (Case #710)

19.6 28-Pin SOIC

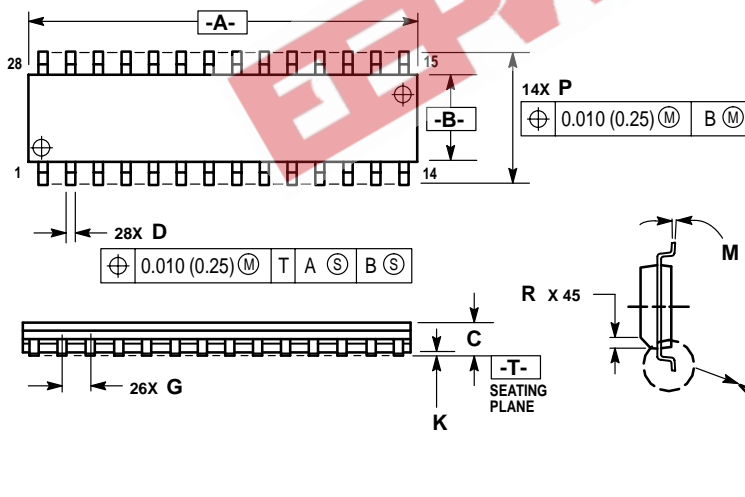

NOTES:

1. DIMENSIONING AND TOLERANCING PER ANSI Y14.5M, 1982.
2. CONTROLLING DIMENSION: MILLIMETER.
3. DIMENSION A AND B DO NOT INCLUDE MOLD PROTRUSION.
4. MAXIMUM MOLD PROTRUSION 0.15 (0.006) PER SIDE.
5. DIMENSION D DOES NOT INCLUDE DAMBAR PROTRUSION. ALLOWABLE DAMBAR PROTRUSION SHALL BE 0.13 (0.005) TOTAL IN EXCESS OF D DIMENSION AT MAXIMUM MATERIAL CONDITION.

DIM	MILLIMETERS		INCHES	
	MIN	MAX	MIN	MAX
A	17.80	18.05	0.701	0.711
B	7.40	7.60	0.292	0.299
C	2.35	2.65	0.093	0.104
D	0.35	0.49	0.014	0.019
F	0.41	0.90	0.016	0.035
G	1.27 BSC		0.050 BSC	
J	0.23	0.32	0.009	0.013
K	0.13	0.29	0.005	0.011
M	0°	8°	0°	8°
P	10.01	10.55	0.395	0.415
R	0.25	0.75	0.010	0.029

Figure 19-4. 28-Pin SOIC (Case #751F)



EEPW 电子产品世界
.com.cn

EEPW 电子产品世界
.com.cn

How to Reach Us:

Home Page:

www.freescale.com

E-mail:

support@freescale.com

USA/Europe or Locations Not Listed:

Freescale Semiconductor
Technical Information Center, CH370
1300 N. Alma School Road
Chandler, Arizona 85224
+1-800-521-6274 or +1-480-768-2130
support@freescale.com

Europe, Middle East, and Africa:

Freescale Halbleiter Deutschland GmbH
Technical Information Center
Schatzbogen 7
81829 Muenchen, Germany
+44 1296 380 456 (English)
+46 8 52200080 (English)
+49 89 92103 559 (German)
+33 1 69 35 48 48 (French)
support@freescale.com

Japan:

Freescale Semiconductor Japan Ltd.
Headquarters
ARCO Tower 15F
1-8-1, Shimo-Meguro, Meguro-ku,
Tokyo 153-0064
Japan
0120 191014 or +81 3 5437 9125
support.japan@freescale.com

Asia/Pacific:

Freescale Semiconductor Hong Kong Ltd.
Technical Information Center
2 Dai King Street
Tai Po Industrial Estate
Tai Po, N.T., Hong Kong
+800 2666 8080
support.asia@freescale.com

For Literature Requests Only:

Freescale Semiconductor Literature Distribution Center
P.O. Box 5405
Denver, Colorado 80217
1-800-441-2447 or 303-675-2140
Fax: 303-675-2150
LDCForFreescaleSemiconductor@hibbertgroup.com

Information in this document is provided solely to enable system and software implementers to use Freescale Semiconductor products. There are no express or implied copyright licenses granted hereunder to design or fabricate any integrated circuits or integrated circuits based on the information in this document.

Freescale Semiconductor reserves the right to make changes without further notice to any products herein. Freescale Semiconductor makes no warranty, representation or guarantee regarding the suitability of its products for any particular purpose, nor does Freescale Semiconductor assume any liability arising out of the application or use of any product or circuit, and specifically disclaims any and all liability, including without limitation consequential or incidental damages. "Typical" parameters that may be provided in Freescale Semiconductor data sheets and/or specifications can and do vary in different applications and actual performance may vary over time. All operating parameters, including "Typicals", must be validated for each customer application by customer's technical experts. Freescale Semiconductor does not convey any license under its patent rights nor the rights of others. Freescale Semiconductor products are not designed, intended, or authorized for use as components in systems intended for surgical implant into the body, or other applications intended to support or sustain life, or for any other application in which the failure of the Freescale Semiconductor product could create a situation where personal injury or death may occur. Should Buyer purchase or use Freescale Semiconductor products for any such unintended or unauthorized application, Buyer shall indemnify and hold Freescale Semiconductor and its officers, employees, subsidiaries, affiliates, and distributors harmless against all claims, costs, damages, and expenses, and reasonable attorney fees arising out of, directly or indirectly, any claim of personal injury or death associated with such unintended or unauthorized use, even if such claim alleges that Freescale Semiconductor was negligent regarding the design or manufacture of the part.

Freescale™ and the Freescale logo are trademarks of Freescale Semiconductor, Inc. All other product or service names are the property of their respective owners. The ARM POWERED logo is a registered trademark of ARM Limited. ARM7TDMI-S is a trademark of ARM Limited. Java and all other Java-based marks are trademarks or registered trademarks of Sun Microsystems, Inc. in the U.S. and other countries. The Bluetooth trademarks are owned by their proprietor and used by Freescale Semiconductor, Inc. under license.

© Freescale Semiconductor, Inc. 2005. All rights reserved.

Rev. 4.1

MC68HC08JL3/H

July 14, 2005

