

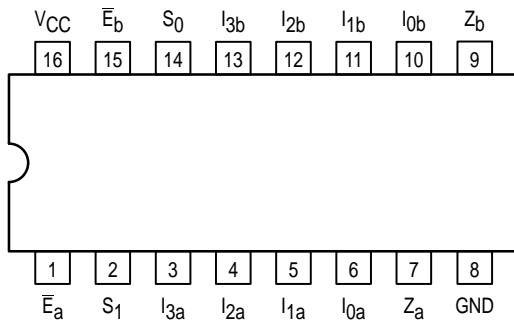

DUAL 4-INPUT MULTIPLEXER

The MC54/74F153 is a high-speed Dual 4-Input Multiplexer with common select inputs and individual enable inputs for each section. It can select two lines of data from four sources. The two buffered outputs present data in the true (non-inverted) form. In addition to multiplexer operation, the F153 can generate any two functions of three variables.

CONNECTION DIAGRAM DIP (TOP VIEW)



LOGIC DIAGRAM

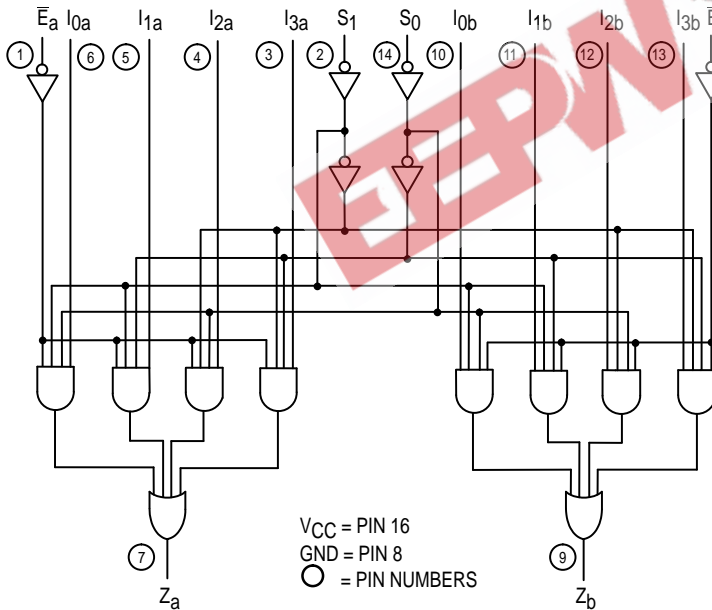

MC54/74F153

DUAL 4-INPUT
MULTIPLEXER
FAST™ SHOTTKY TTL

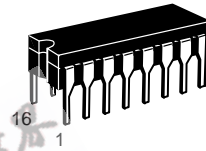

J SUFFIX
CERAMIC
CASE 620-09

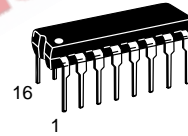

N SUFFIX
PLASTIC
CASE 648-08

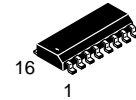

D SUFFIX
SOIC
CASE 751B-03

ORDERING INFORMATION

MC54FXXXJ Ceramic
MC74FXXXN Plastic
MC74FXXXD SOIC

GUARANTEED OPERATING RANGES

Symbol	Parameter		Min	Typ	Max	Unit
V_{CC}	Supply Voltage	54, 74	4.5	5.0	5.5	V
T_A	Operating Ambient Temperature Range	54	-55	25	125	°C
		74	0	25	70	
I_{OH}	Output Current — High	54, 74			-1.0	mA
I_{OL}	Output Current — Low	54, 74			20	mA

MC54/74F153

FUNCTIONAL DESCRIPTION

The MC54/74F153 is a Dual 4-Input Multiplexer. It can select two bits of data from up to four sources under the control of the common Select Inputs (S_0 , S_1). The two 4-input multiplexer circuits have individual active LOW Enables (\bar{E}_a , \bar{E}_b) which can be used to strobe the outputs independently. When the Enables (\bar{E}_a , \bar{E}_b) are HIGH, the corresponding outputs (Z_a , Z_b) are forced LOW.

The F153 is the logic implementation of a 2-pole, 4-position switch, where the position of the switch is determined by the logic levels supplied to the two Select Inputs. The logic equations for the outputs are shown below:

$$Z_a = \bar{E}_a \cdot (I_{0a} \cdot \bar{S}_1 \cdot \bar{S}_0 + I_{1a} \cdot \bar{S}_1 \cdot S_0 + I_{2a} \cdot S_1 \cdot \bar{S}_0 + I_{3a} \cdot S_1 \cdot S_0)$$

$$Z_b = \bar{E}_b \cdot (I_{0b} \cdot \bar{S}_1 \cdot \bar{S}_0 + I_{1b} \cdot \bar{S}_1 \cdot S_0 + I_{2b} \cdot S_1 \cdot \bar{S}_0 + I_{3b} \cdot S_1 \cdot S_0)$$

The F153 can be used to move data from a group of registers to a common output bus. The particular register from which the data came would be determined by the state of the Select Inputs. A less obvious application is as a function generator. The F153 can generate two functions of three variables. This is useful for implementing highly irregular random logic.

FUNCTION TABLE

Select Inputs		Inputs (a or b)					Output
S_0	S_1	\bar{E}	I_0	I_1	I_2	I_3	Z
X	X	H	X	X	X	X	L
L	L	L	L	X	X	X	L
L	L	L	H	X	X	X	H
H	L	L	X	L	X	X	L
H	L	L	X	H	X	X	H
L	H	L	X	X	L	X	L
L	H	L	X	X	H	X	H
H	H	L	X	X	X	L	L
H	H	L	X	X	X	H	H

H = HIGH Voltage Level; L = LOW Voltage Level; X = Don't Care

DC CHARACTERISTICS OVER OPERATING TEMPERATURE RANGE (unless otherwise specified)

Symbol	Parameter	Limits			Unit	Test Conditions
		Min	Typ	Max		
V_{IH}	Input HIGH Voltage	2.0			V	Guaranteed Input HIGH Voltage
V_{IL}	Input LOW Voltage			0.8	V	Guaranteed Input LOW Voltage
V_{IK}	Input Clamp Diode Voltage			-1.2	V	$I_{IN} = -18 \text{ mA}$, $V_{CC} = \text{MIN}$
V_{OH}	Output HIGH Voltage	54, 74	2.5		V	$I_{OL} = -1.0 \text{ mA}$, $V_{CC} = 4.50 \text{ V}$
		74	2.7		V	$I_{OL} = -1.0 \text{ mA}$, $V_{CC} = 4.75 \text{ V}$
V_{OL}	Output LOW Voltage			0.5	V	$I_{OL} = 20 \text{ mA}$, $V_{CC} = \text{MIN}$
I_{IH}	Input HIGH Current			20	μA	$V_{IN} = 2.7 \text{ V}$, $V_{CC} = \text{MAX}$
				0.1	mA	$V_{IN} = 7.0 \text{ V}$, $V_{CC} = \text{MAX}$
I_{IL}	Input LOW Current			-0.6	mA	$V_{IN} = 0.5 \text{ V}$, $V_{CC} = \text{MAX}$
I_{OS}	Output Short Circuit Current (Note 2)	-60		-150	mA	$V_{OUT} = 0 \text{ V}$, $V_{CC} = \text{MAX}$
I_{CC}	Power Supply Current			20	mA	$V_{IN} = \text{GND}$, $V_{CC} = \text{MAX}$

NOTES:

- For conditions shown as MIN or MAX, use the appropriate value specified under recommended operating conditions for the applicable device type.
- Not more than one output should be shorted at a time, nor for more than 1 second.

MC54/74F153

AC CHARACTERISTICS

Symbol	Parameter	54/74F		54F		74F		Unit
		T _A = +25°C V _{CC} = +5.0 V C _L = 50 pF		T _A = -55°C to +125°C V _{CC} = 5.0 V ±10% C _L = 50 pF		T _A = 0°C to 70°C V _{CC} = 5.0 V ±10% C _L = 50 pF		
		Min	Max	Min	Max	Min	Max	
t _{PLH}	Propagation Delay	4.5	10.5	4.5	14	4.5	12	ns
t _{PHL}	S _n to Z _n	3.5	9.0	3.5	11	3.5	10.5	
t _{PLH}	Propagation Delay	4.5	9.0	4.5	11.5	4.5	10.5	ns
t _{PHL}	\bar{E}_n to Z _n	3.0	7.0	2.5	9.0	2.5	8.0	
t _{PLH}	Propagation Delay	3.0	7.0	2.5	9.0	3.0	8.0	ns
t _{PHL}	I _n to Z _n	3.0	6.5	2.5	8.0	2.5	7.5	

EEPW 电子产品世界
.com.cn