

MC74HC4538A

Dual Precision Monostable Multivibrator (Retriggerable, Resettable)

The MC74HC4538A is identical in pinout to the MC14538B. The device inputs are compatible with standard CMOS outputs; with pullup resistors, they are compatible with LSTTL outputs.

This dual monostable multivibrator may be triggered by either the positive or the negative edge of an input pulse, and produces a precision output pulse over a wide range of pulse widths. Because the device has conditioned trigger inputs, there are no trigger-input rise and fall time restrictions. The output pulse width is determined by the external timing components, R_x and C_x . The device has a reset function which forces the Q output low and the \bar{Q} output high, regardless of the state of the output pulse circuitry.

- Unlimited Rise and Fall Times Allowed on the Trigger Inputs
- Output Pulse is Independent of the Trigger Pulse Width
- $\pm 10\%$ Guaranteed Pulse Width Variation from Part to Part (Using the Same Test Jig)
- Output Drive Capability: 10 LSTTL Loads
- Outputs Directly Interface to CMOS, NMOS and TTL
- Operating Voltage Range: 3.0 to 6.0 V
- Low Input Current: 1.0 μ A
- High Noise Immunity Characteristic of CMOS Devices
- In Compliance with the Requirements Defined by JEDEC Standard No. 7A
- Chip Complexity: 145 FETs or 36 Equivalent Gates

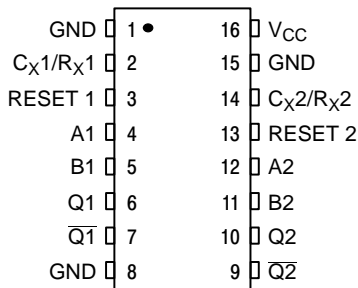

Figure 1. Pin Assignment



ON Semiconductor

<http://onsemi.com>

MARKING DIAGRAMS

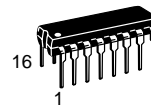

PDIP-16
N SUFFIX
CASE 648

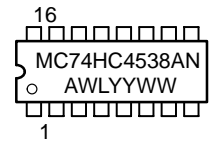

SO-16
D SUFFIX
CASE 751B

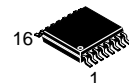
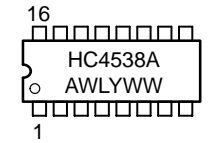

TSSOP-16
DT SUFFIX
CASE 948F

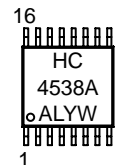

A = Assembly Location
L, WL = Wafer Lot
Y, YY = Year
W, WW = Work Week

ORDERING INFORMATION

Device	Package	Shipping
MC74HC4538AN	PDIP-16	2000/Box
MC74HC4538AD	SOIC-16	48/Rail
MC74HC4538ADR2	SOIC-16	2500/Reel
MC74HC4538ADT	TSSOP-16	96/Rail
MC74HC4538ADTR2	TSSOP-16	2500/Reel

MC74HC4538A

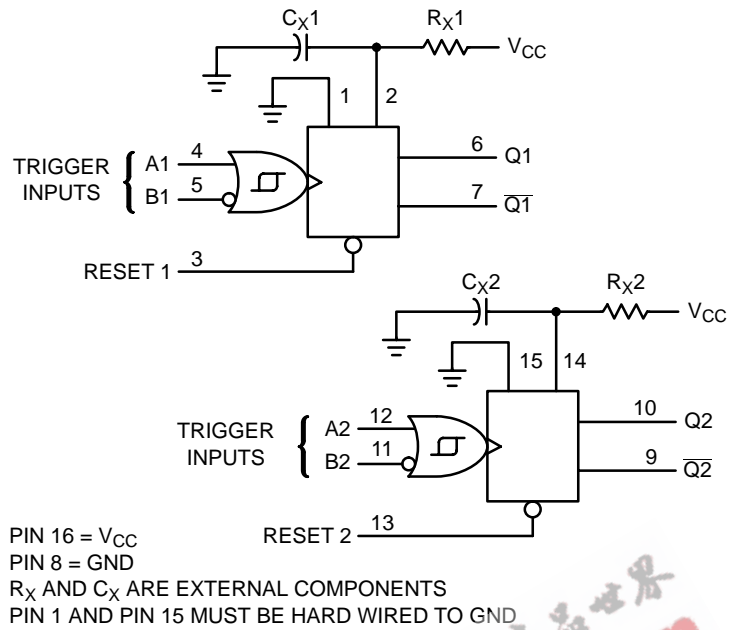

Figure 2. Logic Diagram

FUNCTION TABLE

Inputs			Outputs	
Reset	A	B	Q	\bar{Q}
H	\nearrow	H	\square	\square
H	L	\searrow	\square	\square
H	X	L	Not Triggered	Not Triggered
H	H	X	Not Triggered	Not Triggered
H	L,H, \searrow	H	Not Triggered	Not Triggered
H	L	L,H, \nearrow	Not Triggered	Not Triggered
L	X	X	L	H
\searrow \nearrow	X	X	Not Triggered	Not Triggered

MC74HC4538A

MAXIMUM RATINGS (Note 1)

Symbol	Parameter	Value	Unit
V _{CC}	DC Supply Voltage	−0.5 to +7.0	V
V _I	DC Input Voltage	−0.5 ≤ V _I ≤ V _{CC} + 0.5	V
V _O	DC Output Voltage (Note 2)	−0.5 ≤ V _O ≤ V _{CC} + 0.5	V
I _{IK}	DC Input Diode Current A, B, Reset C _X , R _X	±20 ±30	mA
I _{OK}	DC Output Diode Current	±25	mA
I _O	DC Output Sink Current	±25	mA
I _{CC}	DC Supply Current per Supply Pin	±100	mA
I _{GND}	DC Ground Current per Ground Pin	±100	mA
T _{STG}	Storage Temperature Range	−65 to +150	°C
T _L	Lead temperature, 1 mm from Case for 10 Seconds	260	°C
T _J	Junction temperature under Bias	+150	°C
θ _{JA}	Thermal resistance PDIP SOIC TSSOP	78 112 148	°C/W
P _D	Power Dissipation in Still Air at 85°C PDIP SOIC TSSOP	750 500 450	mW
MSL	Moisture Sensitivity	Level 1	
F _R	Flammability Rating Oxygen Index: 30% – 35%	UL–94–VO (0.125 in)	
V _{ESD}	ESD Withstand Voltage Human Body Model (Note 3) Machine Model (Note 4) Charged Device Model (Note 5)	>2000 >100 >500	V
I _{Latch–Up}	Latch–Up Performance Above V _{CC} and Below GND at 85°C (Note 6)	±300	mA

1. Absolute maximum continuous ratings are those values beyond which damage to the device may occur. Extended exposure to these conditions or conditions beyond those indicated may adversely affect device reliability. Functional operation under absolute maximum-rated conditions is not implied.
2. I_O absolute maximum rating must be observed.
3. Tested to EIA/JESD22–A114–A.
4. Tested to EIA/JESD22–A115–A.
5. Tested to JESD22–C101–A.
6. Tested to EIA/JESD78.
7. For high frequency or heavy load considerations, see the ON Semiconductor High–Speed CMOS Data Book (DL129/D).

RECOMMENDED OPERATING CONDITIONS

Symbol	Parameter	Min	Max	Unit
V _{CC}	DC Supply Voltage (Referenced to GND)	3.0*	6.0	V
V _{in} , V _{out}	DC Input Voltage, Output Voltage (Referenced to GND)	0	V _{CC}	V
T _A	Operating Temperature, All Package Types	−55	+125	°C
t _r , t _f	Input Rise and Fall Time (Figure 7) A or B (Figure 5)	V _{CC} = 2.0 V V _{CC} = 4.5 V V _{CC} = 6.0 V –	1000 500 400 No Limit	ns
R _X	External Timing Resistor V _{CC} < 4.5 V V _{CC} ≥ 4.5 V	1.0 2.0	† †	kΩ
C _X	External Timing Capacitor	0	†	μF

*The HC4538A will function at 2.0 V but for optimum pulse–width stability, V_{CC} should be above 3.0 V.

†The maximum allowable values of R_X and C_X are a function of the leakage of capacitor C_X, the leakage of the HC4538A, and leakage due to board layout and surface resistance. For most applications, C_X/R_X should be limited to a maximum value of 10 μF/1.0 MΩ. Values of C_X > 1.0 μF may cause a problem during power down (see Power Down Considerations). Susceptibility to externally induced noise signals may occur for R_X > 1.0 MΩ.

8. Unused inputs may not be left open. All inputs must be tied to a high–logic voltage level or a low–logic input voltage level.
9. Information on typical parametric values can be found in the ON Semiconductor High–Speed CMOS Data Book (DL129/D).

MC74HC4538A

DC CHARACTERISTICS

Symbol	Parameter	Test Conditions	V _{CC} Volts	Guaranteed Limits						Unit
				-55 to 25°C		≤ 85°C		≤ 125°C		
				Min	Max	Min	Max	Min	Max	
V _{IH}	Minimum High-Level Input Voltage	V _{out} = 0.1 V or V _{CC} - 0.1 V I _{out} ≤ 20 μA	2.0	1.5		1.5		1.5		V
			4.5	3.15		3.15		3.15		
			6.0	4.2		4.2		4.2		
V _{IL}	Maximum Low-Level Input Voltage	V _{out} = 0.1 V or V _{CC} - 0.1 V I _{out} ≤ 20 μA	2.0		0.5		0.5		0.5	V
			4.5		1.35		1.35		1.35	
			6.0		1.8		1.8		1.8	
V _{OH}	Minimum High-Level Output Voltage	V _{in} = V _{IH} or V _{IL} I _{out} ≤ 20 μA	2.0	1.9		1.9		1.9		V
			4.5	4.4		4.4		4.4		
		6.0	5.9		5.9		5.9			
		V _{in} = V _{IH} or V _{IL} I _{out} ≤ -4.0 mA I _{out} ≤ -5.2 mA	4.5	3.98		3.84		3.7		
6.0	5.48			5.34		5.2				
V _{OL}	Maximum Low-Level Output Voltage	V _{in} = V _{IH} or V _{IL} I _{out} ≤ 20 μA	2.0		0.1		0.1		0.1	V
			4.5		0.1		0.1		0.1	
		6.0		0.1		0.1		0.1		
		V _{in} = V _{IH} or V _{IL} I _{out} ≤ 4.0 mA I _{out} ≤ 5.2 mA	4.5		0.26		0.33		0.4	
6.0			0.26		0.33		0.4			
I _{in}	Maximum Input Leakage Current (A, B, Reset)	V _{in} = V _{CC} or GND	6.0		± 0.1		± 1.0		± 1.0	μA
I _{in}	Maximum Input Leakage Current (R _x , C _x)	V _{in} = V _{CC} or GND	6.0		± 50		± 500		± 500	nA
I _{CC}	Maximum Quiescent Supply Current (per package) Standby State	V _{in} = V _{CC} or GND Q1 and Q2 = Low I _{out} = 0 μA	6.0		130		220		350	μA
I _{CC}	Maximum Supply Current (per package) Active State	V _{in} = V _{CC} or GND Q1 and Q2 = High I _{out} = 0 μA Pins 2 and 14 = 0.5 V _{CC}	6.0	25°C		-45°C to 85°C		-55°C to 125°C		μA
					400		600		800	

MC74HC4538A

AC CHARACTERISTICS (C_L = 50 pF, Input t_r = t_f = 6.0 ns)

Symbol	Parameter	V _{CC} Volts	Guaranteed Limits						Unit
			-55 to 25°C		≤ 85°C		≤ 125°C		
			Min	Max	Min	Max	Min	Max	
t _{PLH}	Maximum Propagation Delay Input A or B to Q (Figures 6 and 8)	2.0		175		220		265	ns
		4.5		35		44		53	
		6.0		30		37		45	
t _{PHL}	Maximum Propagation Delay Input A or B to NQ (Figures 6 and 8)	2.0		195		245		295	ns
		4.5		39		49		59	
		6.0		33		42		50	
t _{PHL}	Maximum Propagation Delay Reset to Q (Figures 7 and 8)	2.0		175		220		265	ns
		4.5		35		44		53	
		6.0		30		37		45	
t _{PLH}	Maximum Propagation Delay Reset to NQ (Figures 7 and 8)	2.0		175		220		265	ns
		4.5		35		44		53	
		6.0		30		37		45	
t _{TLH} , t _{THL}	Maximum Output Transition Time, Any Output (Figures 7 and 8)	2.0		75		95		110	ns
		4.5		15		19		22	
		6.0		13		16		19	
C _{in}	Maximum Input Capacitance (A, B, Reset) (C _x , R _x)	—		10		10		10	pF
				25		25		25	

10. For propagation delays with loads other than 50 pF, and information on typical parametric values, see the ON Semiconductor High-Speed CMOS Data Book (DL129/D).

C _{PD}	Power Dissipation Capacitance (per Multivibrator)*	Typical @ 25°C, V _{CC} = 5.0 V		pF
		150		

*Used to determine the no-load dynamic power consumption: P_D = C_{PD} V_{CC}²f + I_{CC} V_{CC}. For load considerations, see the ON Semiconductor High-Speed CMOS Data Book (DL129/D).

TIMING CHARACTERISTICS (Input t_r = t_f = 6.0 ns)

Symbol	Parameter	V _{CC} Volts	Guaranteed Limits						Unit
			-55 to 25°C		≤ 85°C		≤ 125°C		
			Min	Max	Min	Max	Min	Max	
t _{rec}	Minimum Recovery Time, Inactive to A or B (Figure 7)	2.0	0		0		0		ns
		4.5	0		0		0		
		6.0	0		0		0		
t _w	Minimum Pulse Width, Input A or B (Figure 6)	2.0	60		75		90		ns
		4.5	12		15		18		
		6.0	10		13		15		
t _w	Minimum Pulse Width, Reset (Figure 7)	2.0	60		75		90		ns
		4.5	12		15		18		
		6.0	10		13		15		
t _r , t _f	Maximum Input Rise and Fall Times, Reset (Figure 7)	2.0		1000		1000		1000	ns
		4.5		500		500		500	
		6.0		400		400		400	
	A or B (Figure 7)	2.0	No Limit						
		4.5	No Limit						
		6.0	No Limit						

MC74HC4538A

OUTPUT PULSE WIDTH CHARACTERISTICS ($C_L = 50 \text{ pF}$)

Symbol	Parameter	Conditions		Guaranteed Limits						Unit
		Timing Components	V_{CC} Volts	-55 to 25°C		≤ 85°C		≤ 125°C		
				Min	Max	Min	Max	Min	Max	
τ	Output Pulse Width* (Figures 6 and 8)	$R_x = 10 \text{ k}\Omega, C_x = 0.1 \text{ }\mu\text{F}$	5.0	0.63	0.77	0.6	0.8	0.59	0.81	ms
—	Pulse Width Match Between Circuits in the same Package	—	—	± 5.0						%
—	Pulse Width Match Variation (Part to Part)	—	—	± 10						%

*For output pulse widths greater than 100 μs , typically $\tau = kR_xC_x$, where the value of k may be found in Figure 3.

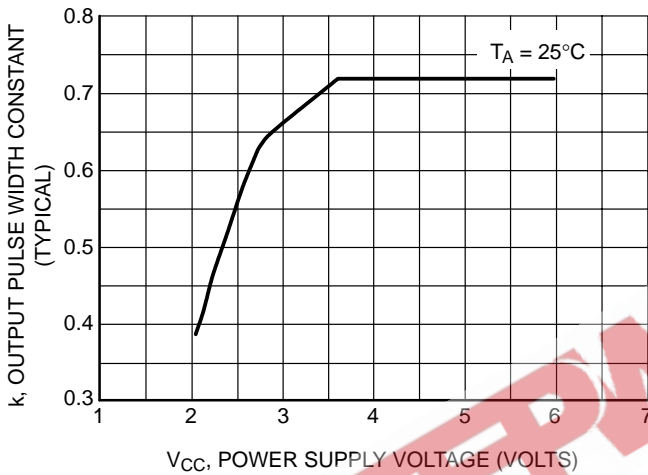

Figure 3. Typical Output Pulse Width Constant, k, versus Supply Voltage
(For output pulse widths > 100 μs : $\tau = kR_xC_x$)

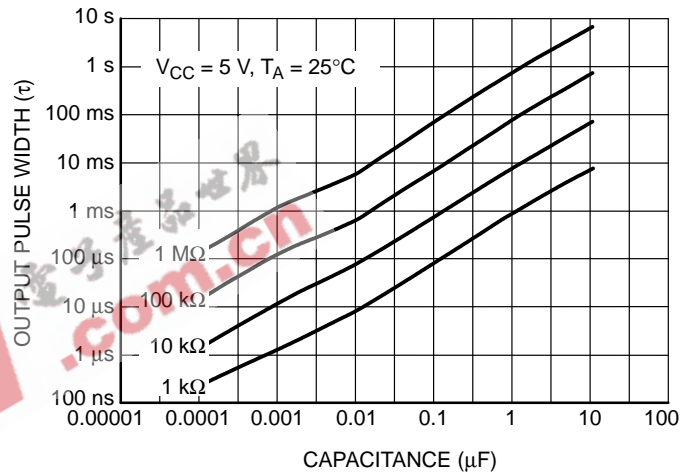

Figure 4. Output Pulse Width versus Timing Capacitance

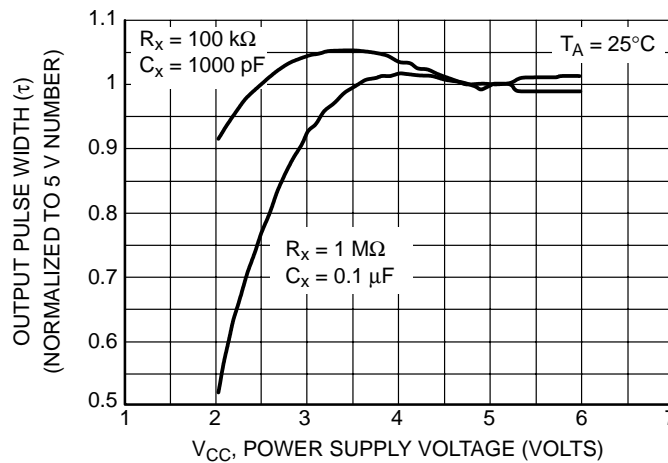

Figure 5. Normalized Output Pulse Width versus Power Supply Voltage

MC74HC4538A

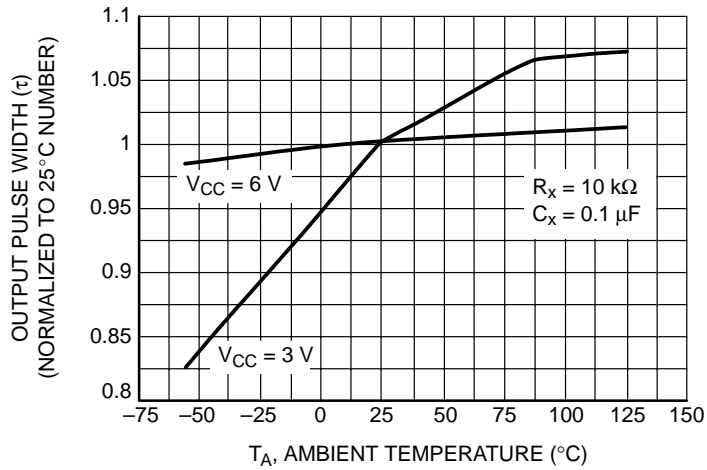

Figure 6. Normalized Output Pulse Width versus Power Supply Voltage

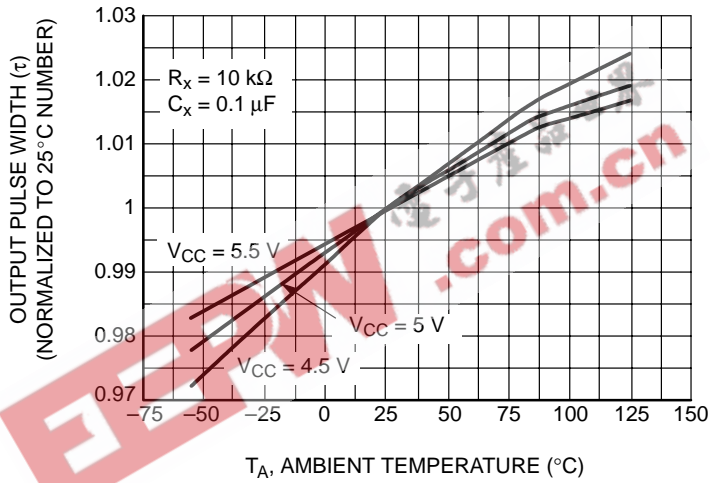

Figure 7. Normalized Output Pulse Width versus Power Supply Voltage

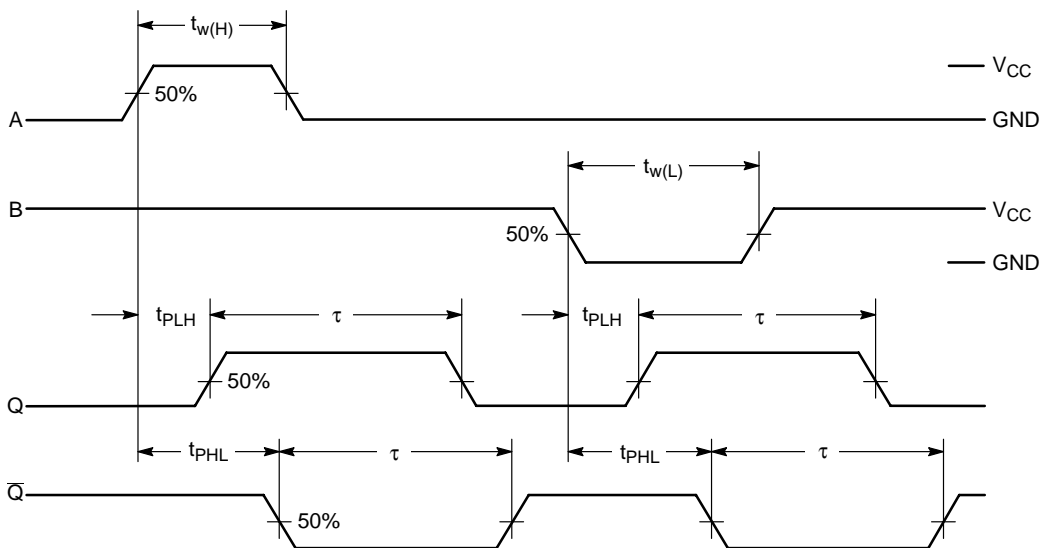

Figure 8. Switching Waveform

MC74HC4538A

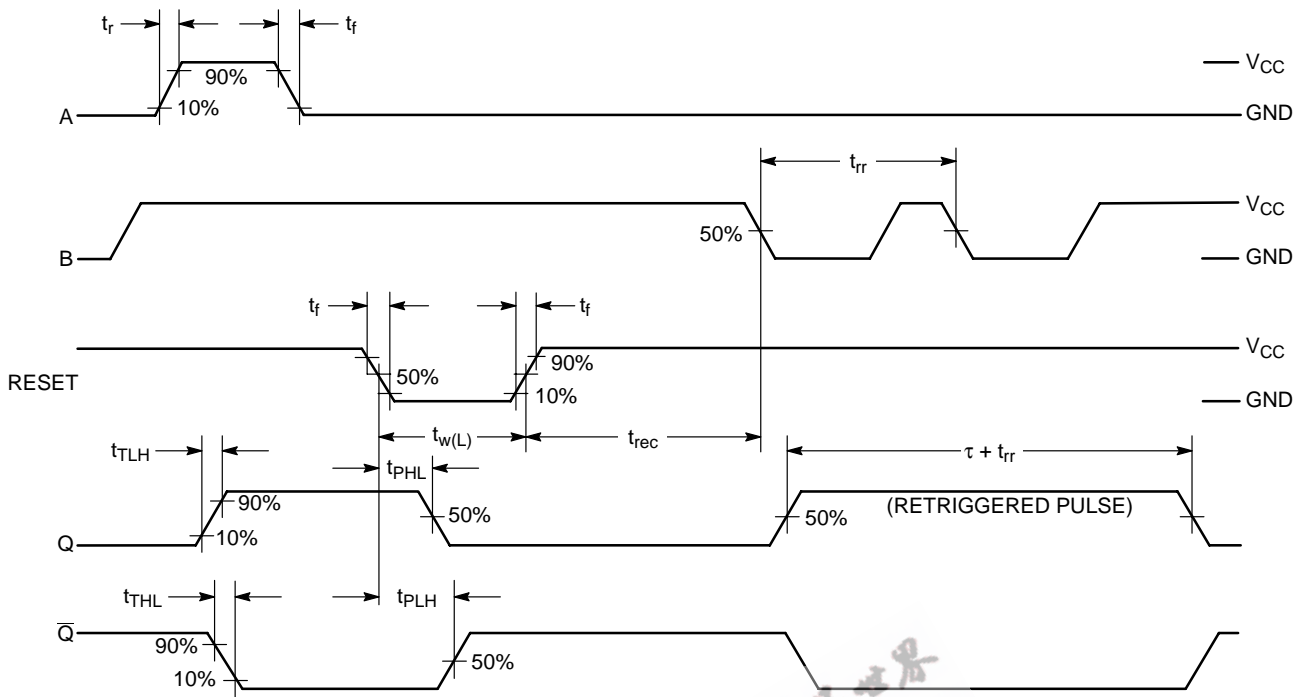
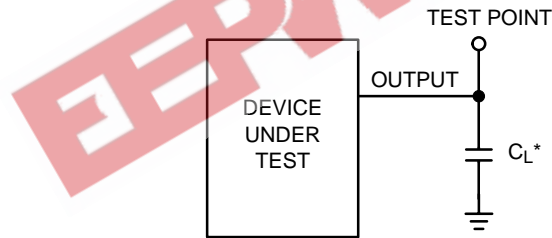

Figure 9. Switching Waveform



*Includes all probe and jig capacitance

Figure 10. Test Circuit

MC74HC4538A

PIN DESCRIPTIONS

INPUTS

A1, A2 (Pins 4, 12)

Positive-edge trigger inputs. A rising-edge signal on either of these pins triggers the corresponding multivibrator when there is a high level on the B1 or B2 input.

B1, B2 (Pins 5, 11)

Negative-edge trigger inputs. A falling-edge signal on either of these pins triggers the corresponding multivibrator when there is a low level on the A1 or A2 input.

Reset 1, Reset 2 (Pins 3, 13)

Reset inputs (active low). When a low level is applied to one of these pins, the Q output of the corresponding multivibrator is reset to a low level and the \bar{Q} output is set to a high level.

C_{X1}/R_{X1} and C_{X2}/R_{X2} (Pins 2 and 14)

External timing components. These pins are tied to the common points of the external timing resistors and

capacitors (see the Block Diagram). Polystyrene capacitors are recommended for optimum pulse width control. Electrolytic capacitors are not recommended due to high leakages associated with these type capacitors.

GND (Pins 1 and 15)

External ground. The external timing capacitors discharge to ground through these pins.

OUTPUTS

Q1, Q2 (Pins 6, 10)

Noninverted monostable outputs. These pins (normally low) pulse high when the multivibrator is triggered at either the A or the B input. The width of the pulse is determined by the external timing components, R_X and C_X.

$\bar{Q}1, \bar{Q}2$ (Pins 7, 9)

Inverted monostable outputs. These pins (normally high) pulse low when the multivibrator is triggered at either the A or the B input. These outputs are the inverse of Q1 and Q2.

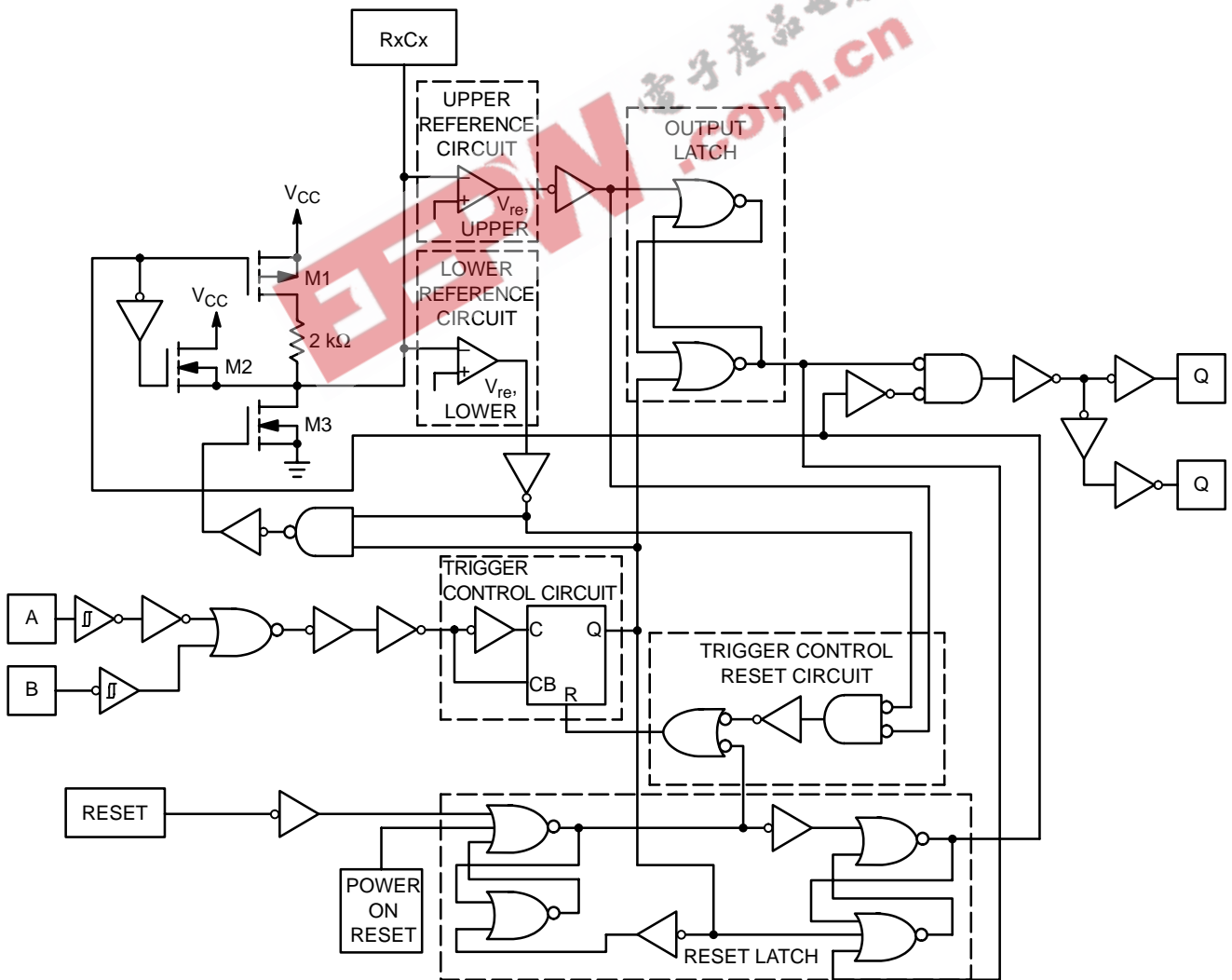

Figure 11. Logic Detail (1/2 the Device)

MC74HC4538A

CIRCUIT OPERATION

Figure 12 shows the HC4538A configured in the retriggerable mode. Briefly, the device operates as follows (refer to Figure 10): In the quiescent state, the external timing capacitor, C_x , is charged to V_{CC} . When a trigger occurs, the Q output goes high and C_x discharges quickly to the lower reference voltage ($V_{ref\ Lower} \approx 1/3 V_{CC}$). C_x then charges, through R_x , back up to the upper reference voltage ($V_{ref\ Upper} \approx 2/3 V_{CC}$), at which point the one-shot has timed out and the Q output goes low.

The following, more detailed description of the circuit operation refers to both the logic detail (Figure 9) and the timing diagram (Figure 10).

QUIESCENT STATE

In the quiescent state, before an input trigger appears, the output latch is high and the reset latch is high (#1 in Figure 10). Thus the Q output (pin 6 or 10) of the monostable multivibrator is low (#2, Figure 10).

The output of the trigger-control circuit is low (#3), and transistors M1, M2, and M3 are turned off. The external timing capacitor, C_x , is charged to V_{CC} (#4), and both the upper and lower reference circuit has a low output (#5).

In addition, the output of the trigger-control reset circuit is low.

TRIGGER OPERATION

The HC4538A is triggered by either a rising-edge signal at input A (#7) or a falling-edge signal at input B (#8), with the unused trigger input and the Reset input held at the voltage levels shown in the Function Table. Either trigger signal will cause the output of the trigger-control circuit to go high (#9).

The trigger-control circuit going high simultaneously initiates two events. First, the output latch goes low, thus taking the Q output of the HC4538A to a high state (#10). Second, transistor M3 is turned on, which allows the external timing capacitor, C_x , to rapidly discharge toward ground (#11). (Note that the voltage across C_x appears at the input of both the upper and lower reference circuit comparator).

When C_x discharges to the reference voltage of the lower reference circuit (#12), the outputs of both reference circuits will be high (#13). The trigger-control reset circuit goes high, resetting the trigger-control circuit flip-flop to a low state (#14). This turns transistor M3 off again, allowing C_x to begin to charge back up toward V_{CC} , with a time constant $t = R_x C_x$ (#15). Once the voltage across C_x charges to above the lower reference voltage, the lower reference circuit will go low allowing the monostable multivibrator to be retriggered.

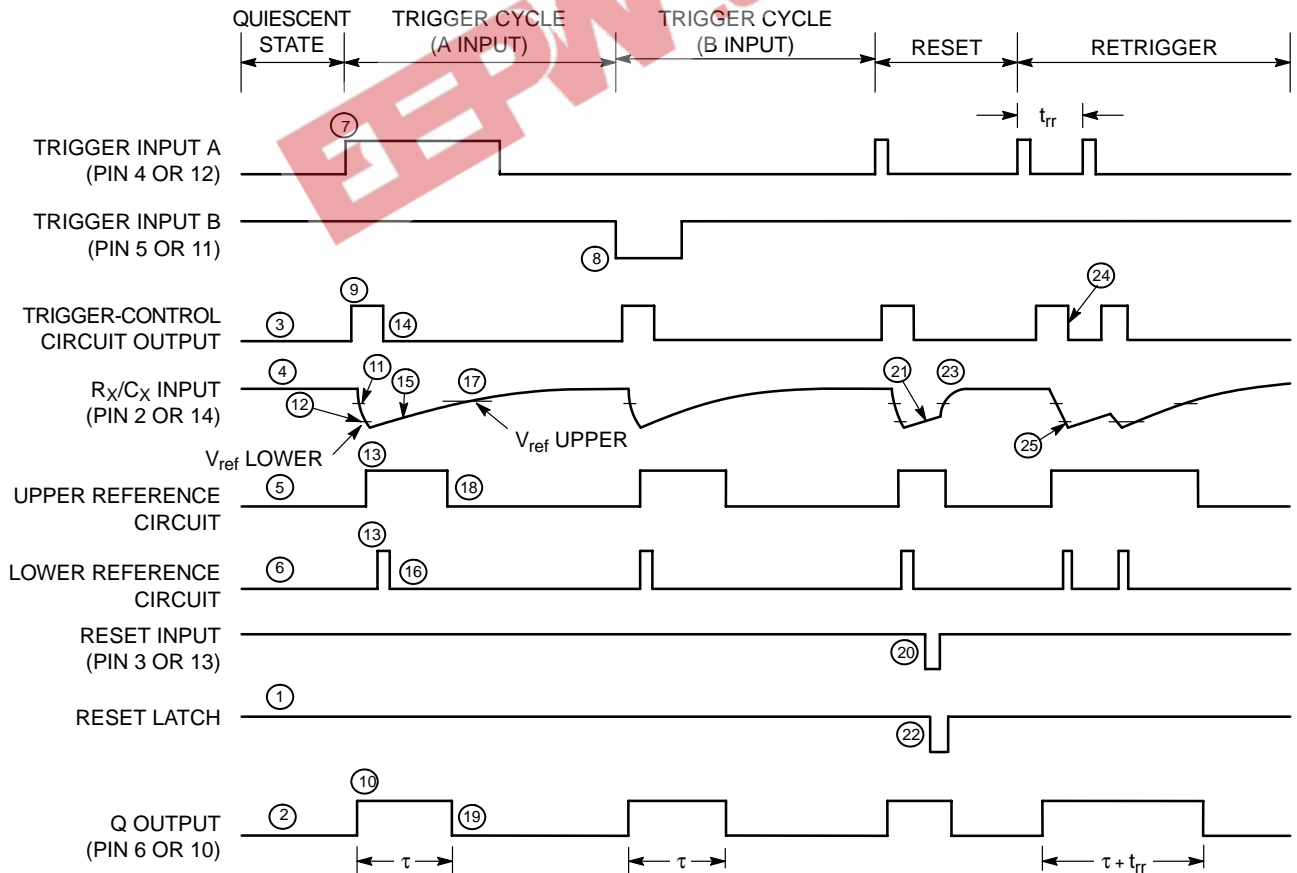

Figure 12. Timing Diagram

MC74HC4538A

When C_x charges up to the reference voltage of the upper reference circuit (#17), the output of the upper reference circuit goes low (#18). This causes the output latch to toggle, taking the Q output of the HC4538A to a low state (#19), and completing the time-out cycle.

POWER-DOWN CONSIDERATIONS

Large values of C_x may cause problems when powering down the HC4538A because of the amount of energy stored in the capacitor. When a system containing this device is powered down, the capacitor may discharge from V_{CC} through the input protection diodes at pin 2 or pin 14. Current through the protection diodes must be limited to 30 mA; therefore, the turn-off time of the V_{CC} power supply must not be faster than $t = V_{CC} \cdot C_x / (30 \text{ mA})$. For example, if $V_{CC} = 5.0 \text{ V}$ and $C_x = 15 \mu\text{F}$, the V_{CC} supply must turn off no faster than $t = (5.0 \text{ V}) \cdot (15 \mu\text{F}) / 30 \text{ mA} = 2.5 \text{ ms}$. This is usually not a problem because power supplies are heavily filtered and cannot discharge at this rate.

When a more rapid decrease of V_{CC} to zero volts occurs, the HC4538A may sustain damage. To avoid this possibility, use an external damping diode, D_x , connected as shown in Figure 11. Best results can be achieved if diode D_x is chosen to be a germanium or Schottky type diode able to withstand large current surges.

RESET AND POWER ON RESET OPERATION

A low voltage applied to the Reset pin always forces the Q output of the HC4538A to a low state.

The timing diagram illustrates the case in which reset occurs (#20) while C_x is charging up toward the reference voltage of the upper reference circuit (#21). When a reset

occurs, the output of the reset latch goes low (#22), turning on transistor M1. Thus C_x is allowed to quickly charge up to V_{CC} (#23) to await the next trigger signal.

On power up of the HC4538A the power-on reset circuit will be high causing a reset condition. This will prevent the trigger-control circuit from accepting a trigger input during this state. The HC4538A's Q outputs are low and the \bar{Q} not outputs are high.

RETRIGGER OPERATION

When used in the retriggerable mode (Figure 12), the HC4538A may be retriggered during timing out of the output pulse at any time after the trigger-control circuit flip-flop has been reset (#24), and the voltage across C_x is above the lower reference voltage. As long as the C_x voltage is below the lower reference voltage, the reset of the flip-flop is high, disabling any trigger pulse. This prevents M3 from turning on during this period resulting in an output pulse width that is predictable.

The amount of undershoot voltage on $R_x C_x$ during the trigger mode is a function of loop delay, M3 conductivity, and V_{DD} . Minimum retrigger time, t_{rr} (Figure 7), is a function of 1) time to discharge $R_x C_x$ from V_{DD} to lower reference voltage ($T_{\text{discharge}}$); 2) loop delay (T_{delay}); 3) time to charge $R_x C_x$ from the undershoot voltage back to the lower reference voltage (T_{charge}).

Figure 13 shows the device configured in the non-retriggerable mode.

For additional information, please see Application Note (AN1558/D) titled *Characterization of Retrigger Time in the HC4538A Dual Precision Monostable Multivibrator*.

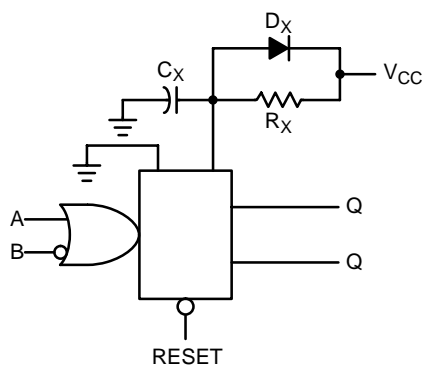

Figure 13. Discharge Protection During Power Down

MC74HC4538A

TYPICAL APPLICATIONS

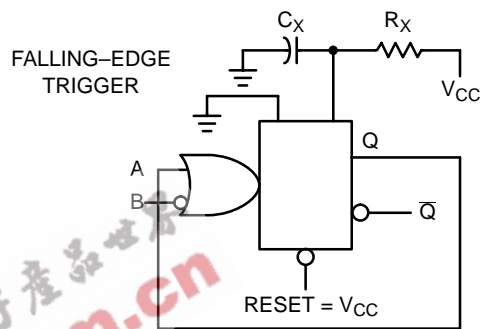
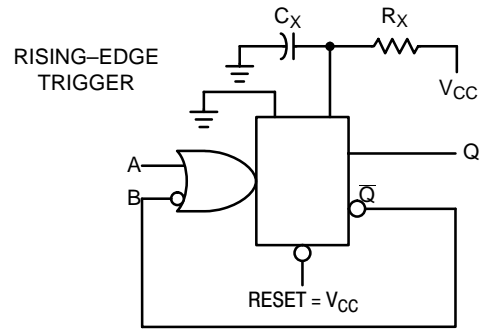
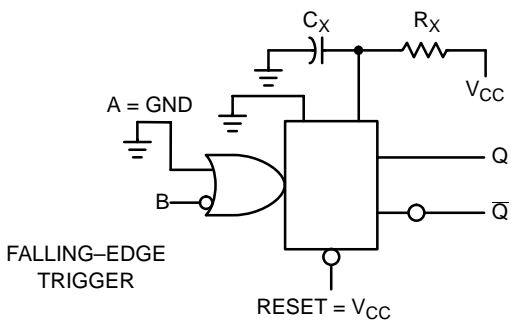
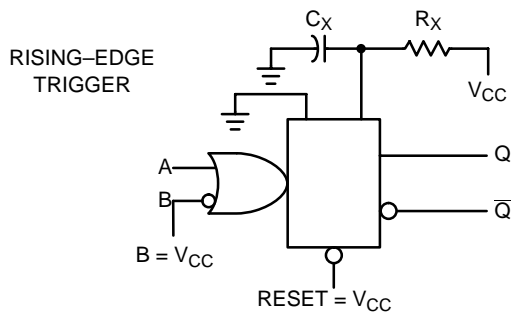

Figure 14. Retriggerable Monostable Circuitry

Figure 15. Non-retriggerable Monostable Circuitry

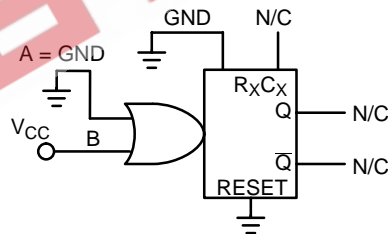
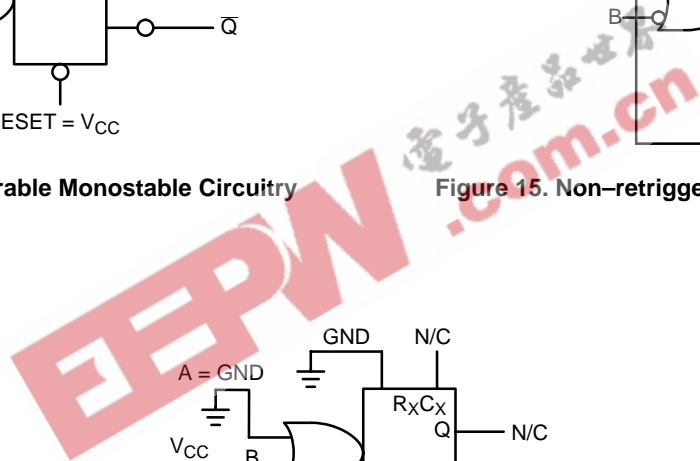

Figure 16. Connection of Unused Section

	100 ns	1 μ s	10 μ s	100 μ s	1 ms	10 ms	100 ms	1 s	10 s	
MC14528B	←-----→									
MC14536B	X									
MC14538B			X							
MC14541B				X						X 23 HR
HC4538A*	X								X	

*Limited operating voltage (2–6 V)

TOTAL OUTPUT PULSE WIDTH RANGE ←-----→

RECOMMENDED PULSE WIDTH RANGE X-----X

MC74HC4538A

PACKAGE DIMENSIONS

PDIP-16
N SUFFIX
CASE 648-08
ISSUE R

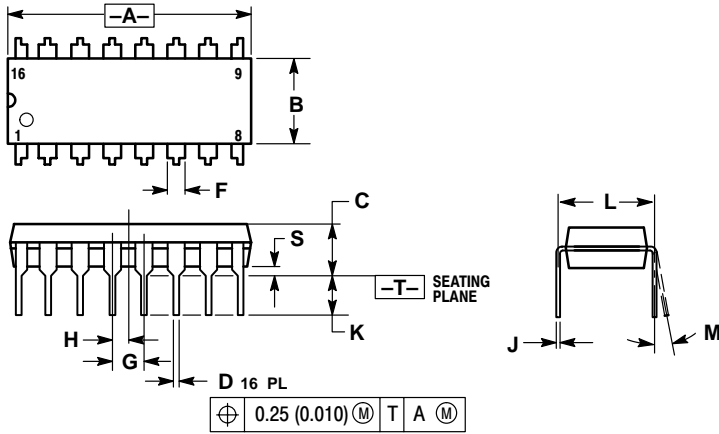

NOTES:

1. DIMENSIONING AND TOLERANCING PER ANSI Y14.5M, 1982.
2. CONTROLLING DIMENSION: INCH.
3. DIMENSION L TO CENTER OF LEADS WHEN FORMED PARALLEL.
4. DIMENSION B DOES NOT INCLUDE MOLD FLASH.
5. ROUNDED CORNERS OPTIONAL.

DIM	INCHES		MILLIMETERS	
	MIN	MAX	MIN	MAX
A	0.740	0.770	18.80	19.55
B	0.250	0.270	6.35	6.85
C	0.145	0.175	3.69	4.44
D	0.015	0.021	0.39	0.53
F	0.040	0.70	1.02	1.77
G	0.100 BSC		2.54 BSC	
H	0.050 BSC		1.27 BSC	
J	0.008	0.015	0.21	0.38
K	0.110	0.130	2.80	3.30
L	0.295	0.305	7.50	7.74
M	0°	10°	0°	10°
S	0.020	0.040	0.51	1.01



MC74HC4538A

PACKAGE DIMENSIONS

SOIC-16
D SUFFIX
CASE 751B-05
ISSUE J

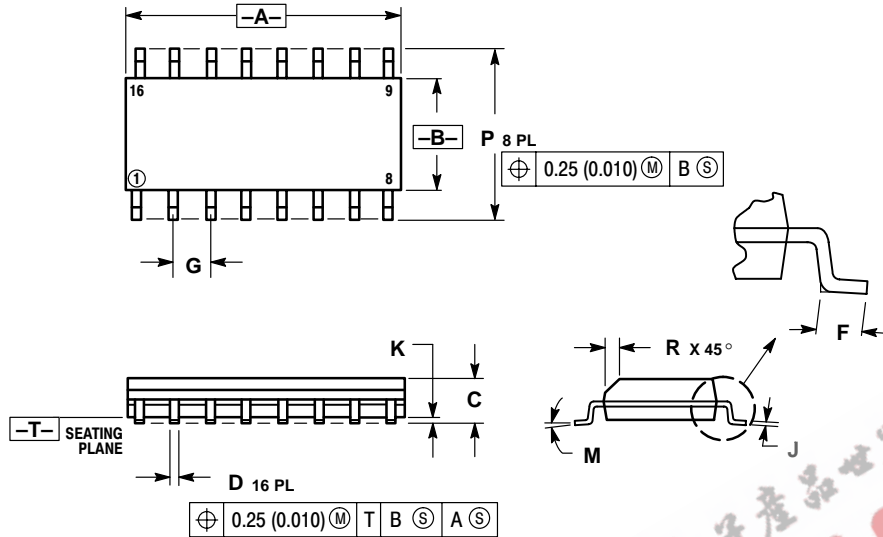

NOTES:

1. DIMENSIONING AND TOLERANCING PER ANSI Y14.5M, 1982.
2. CONTROLLING DIMENSION: MILLIMETER.
3. DIMENSIONS A AND B DO NOT INCLUDE MOLD PROTRUSION.
4. MAXIMUM MOLD PROTRUSION 0.15 (0.006) PER SIDE.
5. DIMENSION D DOES NOT INCLUDE DAMBAR PROTRUSION. ALLOWABLE DAMBAR PROTRUSION SHALL BE 0.127 (0.005) TOTAL IN EXCESS OF THE D DIMENSION AT MAXIMUM MATERIAL CONDITION.

DIM	MILLIMETERS		INCHES	
	MIN	MAX	MIN	MAX
A	9.80	10.00	0.386	0.393
B	3.80	4.00	0.150	0.157
C	1.35	1.75	0.054	0.068
D	0.35	0.49	0.014	0.019
F	0.40	1.25	0.016	0.049
G	1.27 BSC		0.050 BSC	
J	0.19	0.25	0.008	0.009
K	0.10	0.25	0.004	0.009
M	0°	7°	0°	7°
P	5.80	6.20	0.229	0.244
R	0.25	0.50	0.010	0.019

EPW.com.cn 电子产品世界

MC74HC4538A

PACKAGE DIMENSIONS

TSSOP-16
DT SUFFIX
CASE 948F-01
ISSUE O

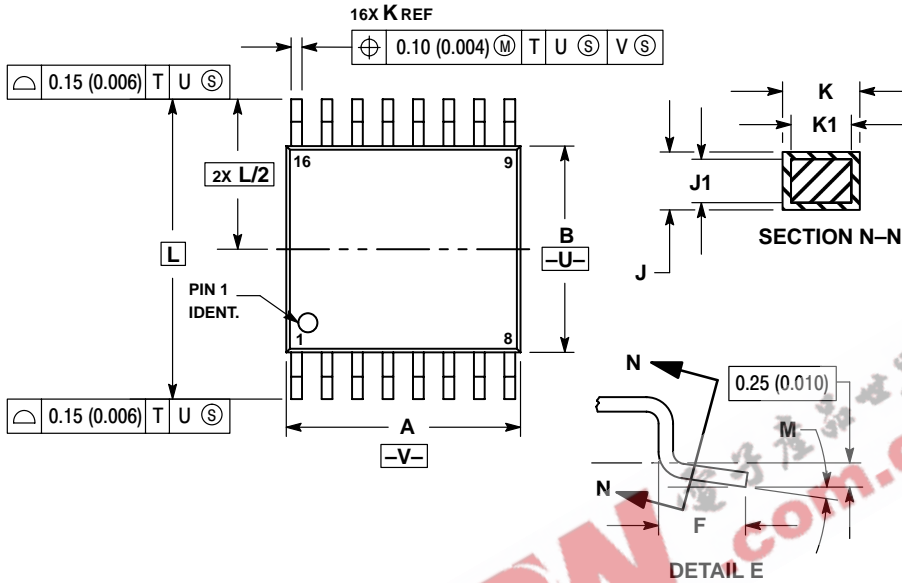

NOTES:

1. DIMENSIONING AND TOLERANCING PER ANSI Y14.5M, 1982.
2. CONTROLLING DIMENSION: MILLIMETER.
3. DIMENSIONS D AND E DO NOT INCLUDE MOLD FLASH OR PROTRUSIONS AND ARE MEASURED AT THE PARTING LINE. MOLD FLASH OR PROTRUSIONS SHALL NOT EXCEED 0.15 (0.006) PER SIDE.
4. TERMINAL NUMBERS ARE SHOWN FOR REFERENCE ONLY.
5. THE LEAD WIDTH DIMENSION (b) DOES NOT INCLUDE DAMBAR PROTRUSION. ALLOWABLE DAMBAR PROTRUSION SHALL BE 0.08 (0.003) TOTAL IN EXCESS OF THE LEAD WIDTH DIMENSION AT MAXIMUM MATERIAL CONDITION. DAMBAR CANNOT BE LOCATED ON THE LOWER RADIUS OR THE FOOT. MINIMUM SPACE BETWEEN PROTRUSIONS AND ADJACENT LEAD TO BE 0.46 (0.018).

DIM	MILLIMETERS		INCHES	
	MIN	MAX	MIN	MAX
A	4.90	5.10	0.193	0.200
B	4.30	4.50	0.169	0.177
C	---	1.20	---	0.047
D	0.05	0.15	0.002	0.006
F	0.50	0.75	0.020	0.030

MC74HC4538A

EEPW 电子产品世界 .com.cn

ON Semiconductor and  are trademarks of Semiconductor Components Industries, LLC (SCILLC). SCILLC reserves the right to make changes without further notice to any products herein. SCILLC makes no warranty, representation or guarantee regarding the suitability of its products for any particular purpose, nor does SCILLC assume any liability arising out of the application or use of any product or circuit, and specifically disclaims any and all liability, including without limitation special, consequential or incidental damages. "Typical" parameters which may be provided in SCILLC data sheets and/or specifications can and do vary in different applications and actual performance may vary over time. All operating parameters, including "Typicals" must be validated for each customer application by customer's technical experts. SCILLC does not convey any license under its patent rights nor the rights of others. SCILLC products are not designed, intended, or authorized for use as components in systems intended for surgical implant into the body, or other applications intended to support or sustain life, or for any other application in which the failure of the SCILLC product could create a situation where personal injury or death may occur. Should Buyer purchase or use SCILLC products for any such unintended or unauthorized application, Buyer shall indemnify and hold SCILLC and its officers, employees, subsidiaries, affiliates, and distributors harmless against all claims, costs, damages, and expenses, and reasonable attorney fees arising out of, directly or indirectly, any claim of personal injury or death associated with such unintended or unauthorized use, even if such claim alleges that SCILLC was negligent regarding the design or manufacture of the part. SCILLC is an Equal Opportunity/Affirmative Action Employer.

PUBLICATION ORDERING INFORMATION

NORTH AMERICA Literature Fulfillment:

Literature Distribution Center for ON Semiconductor
P.O. Box 5163, Denver, Colorado 80217 USA
Phone: 303-675-2175 or 800-344-3860 Toll Free USA/Canada
Fax: 303-675-2176 or 800-344-3867 Toll Free USA/Canada
Email: ONlit@hibbertco.com
Fax Response Line: 303-675-2167 or 800-344-3810 Toll Free USA/Canada

N. American Technical Support: 800-282-9855 Toll Free USA/Canada

EUROPE: LDC for ON Semiconductor – European Support

German Phone: (+1) 303-308-7140 (Mon–Fri 2:30pm to 7:00pm CET)
Email: ONlit-german@hibbertco.com
French Phone: (+1) 303-308-7141 (Mon–Fri 2:00pm to 7:00pm CET)
Email: ONlit-french@hibbertco.com
English Phone: (+1) 303-308-7142 (Mon–Fri 12:00pm to 5:00pm GMT)
Email: ONlit@hibbertco.com

EUROPEAN TOLL-FREE ACCESS*: 00-800-4422-3781

*Available from Germany, France, Italy, UK, Ireland

CENTRAL/SOUTH AMERICA:

Spanish Phone: 303-308-7143 (Mon–Fri 8:00am to 5:00pm MST)
Email: ONlit-spanish@hibbertco.com
Toll-Free from Mexico: Dial 01-800-288-2872 for Access –
then Dial 866-297-9322

ASIA/PACIFIC: LDC for ON Semiconductor – Asia Support

Phone: 1-303-675-2121 (Tue–Fri 9:00am to 1:00pm, Hong Kong Time)
Toll Free from Hong Kong & Singapore:
001-800-4422-3781
Email: ONlit-asia@hibbertco.com

JAPAN: ON Semiconductor, Japan Customer Focus Center

4-32-1 Nishi-Gotanda, Shinagawa-ku, Tokyo, Japan 141-0031
Phone: 81-3-5740-2700
Email: r14525@onsemi.com

ON Semiconductor Website: <http://onsemi.com>

For additional information, please contact your local Sales Representative.