

MC74LVX8053

Analog Multiplexer / Demultiplexer High-Performance Silicon-Gate CMOS

The MC74LVX8053 utilizes silicon-gate CMOS technology to achieve fast propagation delays, low ON resistances, and low OFF leakage currents. This analog multiplexer/demultiplexer controls analog voltages that may vary across the complete power supply range (from V_{CC} to GND).

The LVX8053 is similar in pinout to the high-speed HC4053A, and the metal-gate MC14053B. The Channel-Select inputs determine which one of the Analog Inputs/Outputs is to be connected, by means of an analog switch, to the Common Output/Input. When the Enable pin is HIGH, all analog switches are turned off.

The Channel-Select and Enable inputs are compatible with standard CMOS outputs; with pull-up resistors they are compatible with LSTTL outputs.

This device has been designed so that the ON resistance (R_{ON}) is more linear over input voltage than R_{ON} of metal-gate CMOS analog switches.

- Fast Switching and Propagation Speeds
- Low Crosstalk Between Switches
- Diode Protection on All Inputs/Outputs
- Analog Power Supply Range ($V_{CC} - GND$) = 2.0 to 6.0 V
- Digital (Control) Power Supply Range ($V_{CC} - GND$) = 2.0 to 6.0 V
- Improved Linearity and Lower ON Resistance Than Metal-Gate Counterparts
- Low Noise
- In Compliance With the Requirements of JEDEC Standard No. 7A
- Chip Complexity: LVX8053 — 156 FETs or 39 Equivalent Gates

LOGIC DIAGRAM

Triple Single-Pole, Double-Position Plus Common Off

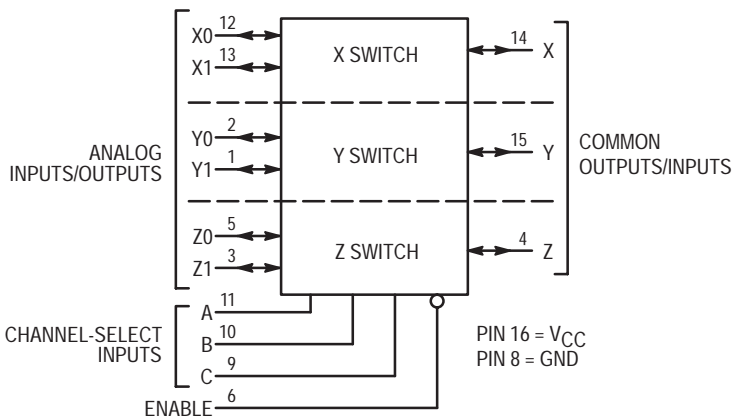

NOTE: This device allows independent control of each switch. Channel-Select Input A controls the X-Switch, Input B controls the Y-Switch and Input C controls the Z-Switch



ON Semiconductor

<http://onsemi.com>

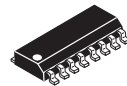

16-LEAD SOIC
D SUFFIX
CASE 751B

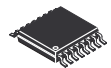

16-LEAD TSSOP
DT SUFFIX
CASE 948F

PIN CONNECTION AND MARKING DIAGRAM (Top View)

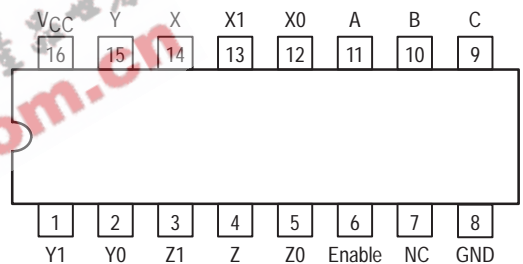

For detailed package marking information, see the Marking Diagram section on page 11 of this data sheet.

FUNCTION TABLE – MC74LVX8053

Control Inputs			ON Channels			
Enable	Select					
	C	B	A			
L	L	L	L	Z0	Y0	X0
L	L	L	H	Z0	Y0	X1
L	L	H	L	Z0	Y1	X0
L	L	H	H	Z0	Y1	X1
L	H	L	L	Z1	Y0	X0
L	H	L	H	Z1	Y0	X1
L	H	H	L	Z1	Y1	X0
L	H	H	H	Z1	Y1	X1
H	X	X	X	NONE		

X = Don't Care

ORDERING INFORMATION

Device	Package	Shipping
MC74LVX8053D	SOIC	48 Units/Rail
MC74LVX8053DR2	SOIC	2500 Units/Reel
MC74LVX8053DT	TSSOP	96 Units/Rail
MC74LVX8053DTR2	TSSOP	2500 Units/Reel

MC74LVX8053

MAXIMUM RATINGS*

Symbol	Parameter	Value	Unit
V_{CC}	Positive DC Supply Voltage (Referenced to GND)	- 0.5 to + 7.0	V
V_{IS}	Analog Input Voltage	- 0.5 to $V_{CC} + 0.5$	V
V_{in}	Digital Input Voltage (Referenced to GND)	- 0.5 to $V_{CC} + 0.5$	V
I	DC Current, Into or Out of Any Pin	± 20	mA
P_D	Power Dissipation in Still Air, SOIC Package† TSSOP Package†	500 450	mW
T_{stg}	Storage Temperature Range	- 65 to + 150	°C
T_L	Lead Temperature, 1 mm from Case for 10 Seconds	260	°C

*Maximum Ratings are those values beyond which damage to the device may occur. Functional operation should be restricted to the Recommended Operating Conditions.

†Derating — SOIC Package: - 7 mW/°C from 65° to 125°C
TSSOP Package: - 6.1 mW/°C from 65° to 125°C

This device contains protection circuitry to guard against damage due to high static voltages or electric fields. However, precautions must be taken to avoid applications of any voltage higher than maximum rated voltages to this high-impedance circuit. For proper operation, V_{in} and V_{out} should be constrained to the range $GND \leq (V_{in} \text{ or } V_{out}) \leq V_{CC}$. Unused inputs must always be tied to an appropriate logic voltage level (e.g., either GND or V_{CC}). Unused outputs must be left open.

RECOMMENDED OPERATING CONDITIONS

Symbol	Parameter	Min	Max	Unit
V_{CC}	Positive DC Supply Voltage (Referenced to GND)	2.0	6.0	V
V_{IS}	Analog Input Voltage	0.0	V_{CC}	V
V_{in}	Digital Input Voltage (Referenced to GND)	GND	V_{CC}	V
V_{IO}^*	Static or Dynamic Voltage Across Switch		1.2	V
T_A	Operating Temperature Range, All Package Types	- 55	+ 85	°C
t_r, t_f	Input Rise/Fall Time (Channel Select or Enable Inputs)			ns/V
	$V_{CC} = 3.3 \text{ V} \pm 0.3 \text{ V}$	0	100	
	$V_{CC} = 5.0 \text{ V} \pm 0.5 \text{ V}$	0	20	

*For voltage drops across switch greater than 1.2 V (switch on), excessive V_{CC} current may be drawn; i.e., the current out of the switch may contain both V_{CC} and switch input components. The reliability of the device will be unaffected unless the Maximum Ratings are exceeded.

MC74LVX8053

DC CHARACTERISTICS — Digital Section (Voltages Referenced to GND)

Symbol	Parameter	Condition	V _{CC} V	Guaranteed Limit			Unit
				-55 to 25°C	≤85°C	≤125°C	
V _{IH}	Minimum High-Level Input Voltage, Channel-Select or Enable Inputs	R _{ON} = Per Spec	2.0	1.50	1.50	1.50	V
			3.0	2.10	2.10	2.10	
			4.5	3.15	3.15	3.15	
			5.5	3.85	3.85	3.85	
V _{IL}	Maximum Low-Level Input Voltage, Channel-Select or Enable Inputs	R _{ON} = Per Spec	2.0	0.5	0.5	0.5	V
			3.0	0.9	0.9	0.9	
			4.5	1.35	1.35	1.35	
			5.5	1.65	1.65	1.65	
I _{in}	Maximum Input Leakage Current, Channel-Select or Enable Inputs	V _{in} = V _{CC} or GND,	5.5	±0.1	±1.0	±1.0	μA
I _{CC}	Maximum Quiescent Supply Current (per Package)	Channel Select, Enable and V _{IS} = V _{CC} or GND; V _{IO} = 0 V	5.5	4	40	160	μA

DC ELECTRICAL CHARACTERISTICS Analog Section

Symbol	Parameter	Test Conditions	V _{CC} V	Guaranteed Limit			Unit
				-55 to 25°C	≤ 85°C	≤ 125°C	
R _{ON}	Maximum "ON" Resistance	V _{in} = V _{IL} or V _{IH} V _{IS} = V _{CC} to GND I _S ≤ 10.0 mA (Figures 1, 2)	3.0	40	45	50	Ω
			4.5	30	32	37	
		5.5	25	28	30		
		V _{in} = V _{IL} or V _{IH} V _{IS} = V _{CC} or GND (Endpoints) I _S ≤ 10.0 mA (Figures 1, 2)	3.0	30	35	40	
			4.5	25	28	35	
			5.5	20	25	30	
ΔR _{ON}	Maximum Difference in "ON" Resistance Between Any Two Channels in the Same Package	V _{in} = V _{IL} or V _{IH} V _{IS} = 1/2 (V _{CC} - GND) I _S ≤ 10.0 mA	3.0	15	20	25	Ω
			4.5	8.0	12	15	
			5.5	8.0	12	15	
I _{off}	Maximum Off-Channel Leakage Current, Any One Channel	V _{in} = V _{IL} or V _{IH} ; V _{IO} = V _{CC} or GND; Switch Off (Figure 3)	5.5	0.1	0.5	1.0	μA
	Maximum Off-Channel Leakage Current, Common Channel	V _{in} = V _{IL} or V _{IH} ; V _{IO} = V _{CC} or GND; Switch Off (Figure 4)	5.5	0.1	1.0	2.0	
I _{on}	Maximum On-Channel Leakage Current, Channel-to-Channel	V _{in} = V _{IL} or V _{IH} ; Switch-to-Switch = V _{CC} or GND; (Figure 5)	5.5	0.1	1.0	2.0	μA

MC74LVX8053

AC CHARACTERISTICS (C_L = 50 pF, Input t_r = t_f = 3 ns)

Symbol	Parameter	V _{CC} V	Guaranteed Limit			Unit
			-55 to 25°C	≤85°C	≤125°C	
t _{PLH} , t _{PHL}	Maximum Propagation Delay, Channel–Select to Analog Output (Figure 9)	2.0	30	35	40	ns
		3.0	20	25	30	
		4.5	15	18	22	
		5.5	15	18	20	
t _{PLH} , t _{PHL}	Maximum Propagation Delay, Analog Input to Analog Output (Figure 10)	2.0	4.0	6.0	8.0	ns
		3.0	3.0	5.0	6.0	
		4.5	1.0	2.0	2.0	
		5.5	1.0	2.0	2.0	
t _{PLZ} , t _{PHZ}	Maximum Propagation Delay, Enable to Analog Output (Figure 11)	2.0	30	35	40	ns
		3.0	20	25	30	
		4.5	15	18	22	
		5.5	15	18	20	
t _{PZL} , t _{PZH}	Maximum Propagation Delay, Enable to Analog Output (Figure 11)	2.0	20	25	30	ns
		3.0	12	14	15	
		4.5	8.0	10	12	
		5.5	8.0	10	12	
C _{in}	Maximum Input Capacitance, Channel–Select or Enable Inputs		10	10	10	pF
C _{I/O}	Maximum Capacitance (All Switches Off)	Analog I/O	35	35	35	pF
		Common O/I	50	50	50	
		Feedthrough	1.0	1.0	1.0	
C _{PD}	Power Dissipation Capacitance (Figure 13)*	Typical @ 25°C, V _{CC} = 5.0 V			pF	
		45				

* Used to determine the no-load dynamic power consumption: $P_D = C_{PD} V_{CC}^2 f + I_{CC} V_{CC}$.

MC74LVX8053

ADDITIONAL APPLICATION CHARACTERISTICS (GND = 0 V)

Symbol	Parameter	Condition	V _{CC} V	Limit*	Unit
				25°C	
BW	Maximum On-Channel Bandwidth or Minimum Frequency Response (Figure 6)	f _{in} = 1MHz Sine Wave; Adjust f _{in} Voltage to Obtain 0dBm at V _{OIS} ; Increase f _{in} Frequency Until dB Meter Reads -3dB; R _L = 50Ω, C _L = 10pF	3.0 4.5 5.5	120 120 120	MHz
—	Off-Channel Feedthrough Isolation (Figure 7)	f _{in} = Sine Wave; Adjust f _{in} Voltage to Obtain 0dBm at V _{IS} f _{in} = 10kHz, R _L = 600Ω, C _L = 50pF	3.0 4.5 5.5	-50 -50 -50	dB
		f _{in} = 1.0MHz, R _L = 50Ω, C _L = 10pF	3.0 4.5 5.5	-37 -37 -37	
—	Feedthrough Noise. Channel-Select Input to Common I/O (Figure 8)	V _{in} ≤ 1MHz Square Wave (t _r = t _f = 6ns); Adjust R _L at Setup so that I _S = 0A; Enable = GND R _L = 600Ω, C _L = 50pF	3.0 4.5 5.5	25 105 135	mV _{pp}
		R _L = 10kΩ, C _L = 10pF	3.0 4.5 5.5	35 145 190	
—	Crosstalk Between Any Two Switches (Figure 12)	f _{in} = Sine Wave; Adjust f _{in} Voltage to Obtain 0dBm at V _{IS} f _{in} = 10kHz, R _L = 600Ω, C _L = 50pF	3.0 4.5 5.5	-50 -50 -50	dB
		f _{in} = 1.0MHz, R _L = 50Ω, C _L = 10pF	3.0 4.5 5.5	-60 -60 -60	
THD	Total Harmonic Distortion (Figure 14)	f _{in} = 1kHz, R _L = 10kΩ, C _L = 50pF THD = THD _{measured} - THD _{source} V _{IS} = 2.0V _{pp} sine wave V _{IS} = 4.0V _{pp} sine wave V _{IS} = 5.5V _{pp} sine wave	3.0 4.5 5.5	0.10 0.08 0.05	%

*Limits not tested. Determined by design and verified by qualification.

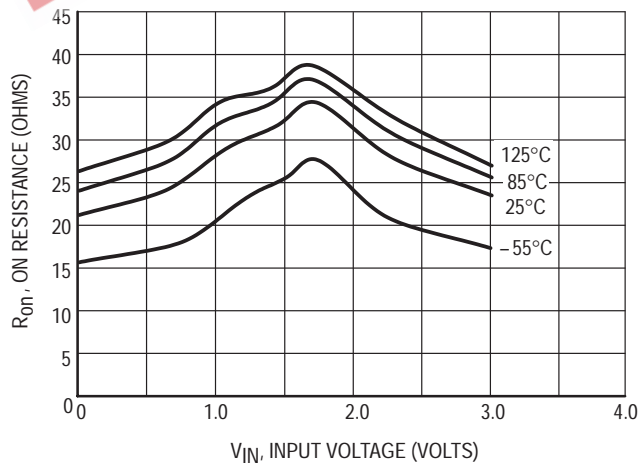

Figure 1a. Typical On Resistance, V_{CC} = 3.0 V

MC74LVX8053

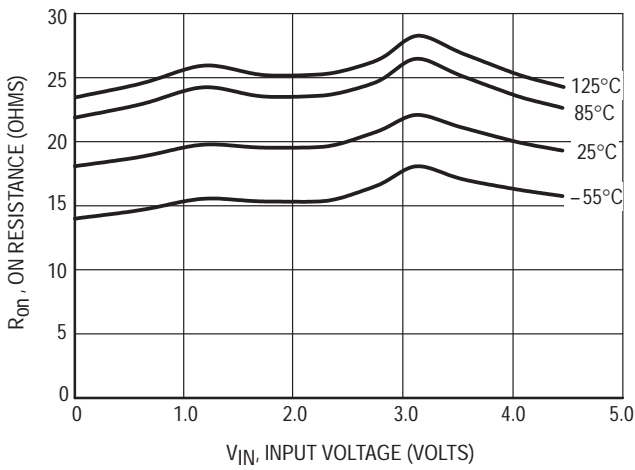

Figure 1b. Typical On Resistance, $V_{CC} = 4.5\text{ V}$

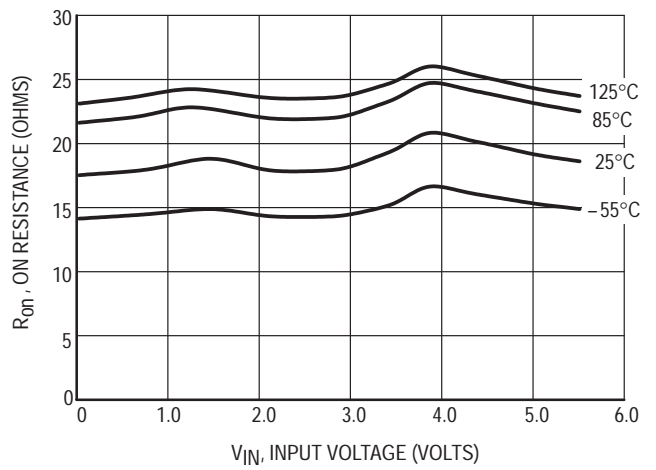

Figure 1c. Typical On Resistance, $V_{CC} = 5.5\text{ V}$

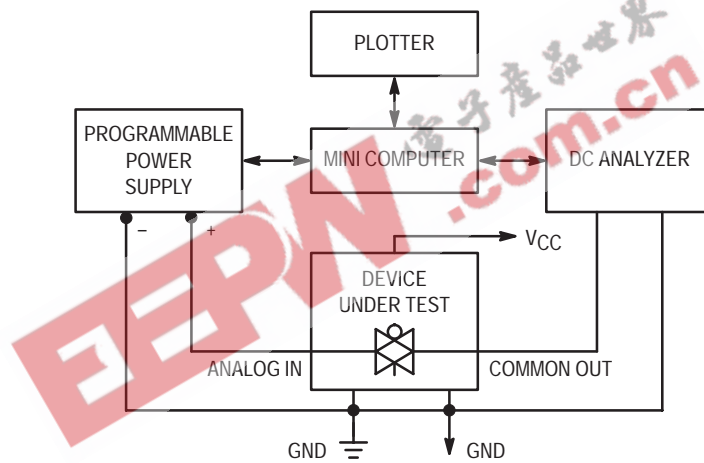

Figure 2. On Resistance Test Set-Up

MC74LVX8053

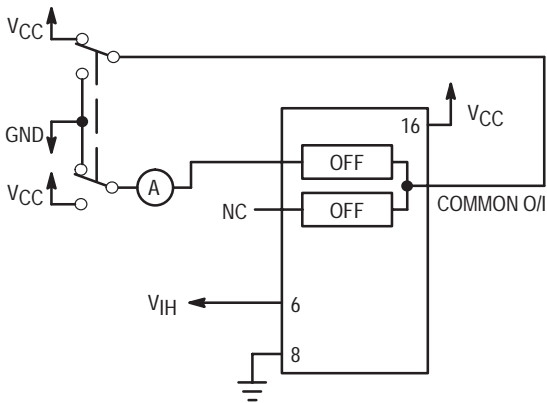

Figure 3. Maximum Off Channel Leakage Current, Any One Channel, Test Set-Up

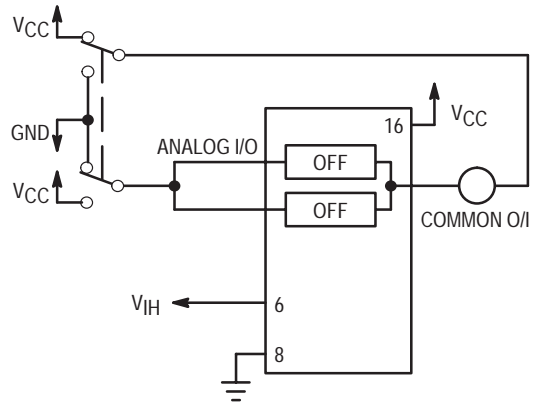

Figure 4. Maximum Off Channel Leakage Current, Common Channel, Test Set-Up

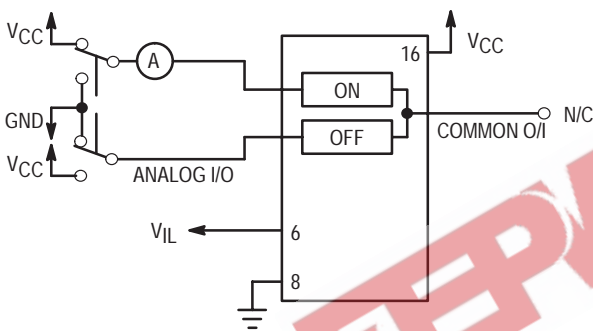
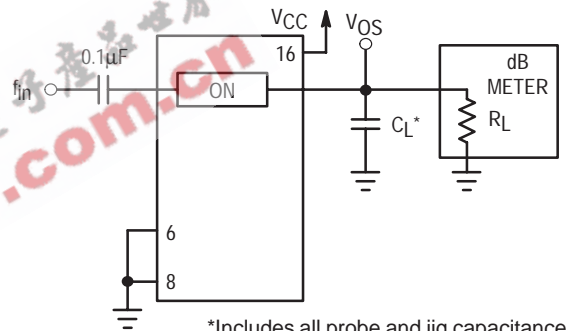
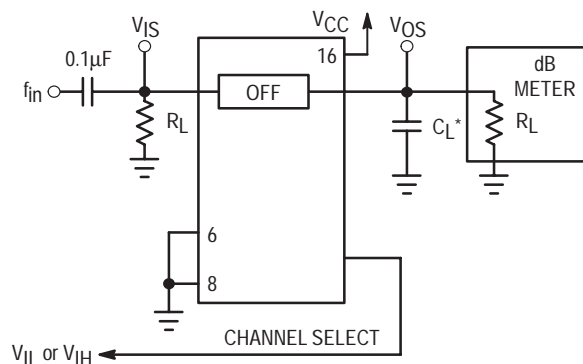

Figure 5. Maximum On Channel Leakage Current, Channel to Channel, Test Set-Up



*Includes all probe and jig capacitance

Figure 6. Maximum On Channel Bandwidth, Test Set-Up



*Includes all probe and jig capacitance

Figure 7. Off Channel Feedthrough Isolation, Test Set-Up

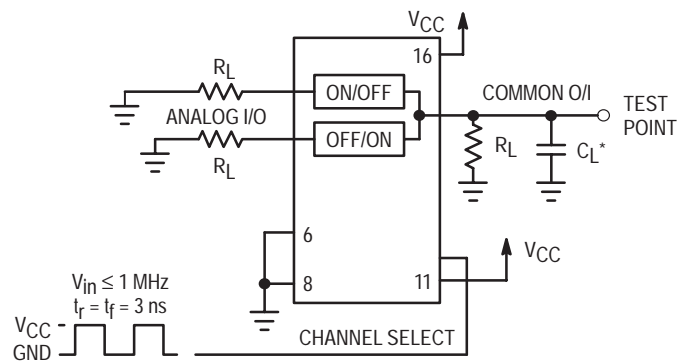

*Includes all probe and jig capacitance

Figure 8. Feedthrough Noise, Channel Select to Common Out, Test Set-Up

MC74LVX8053

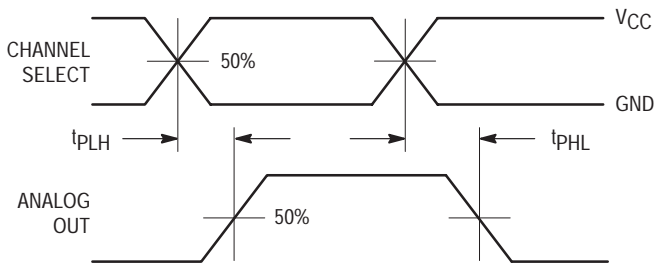
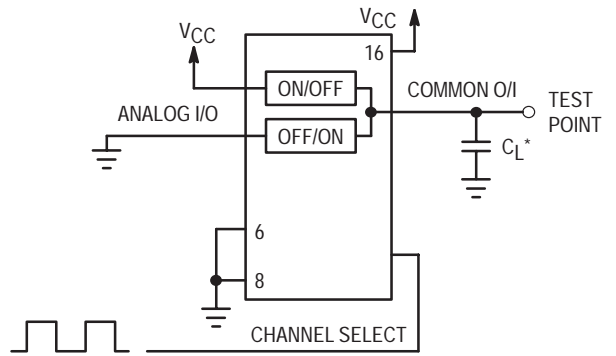

Figure 9a. Propagation Delays, Channel Select to Analog Out



*Includes all probe and jig capacitance

Figure 9b. Propagation Delay, Test Set-Up Channel Select to Analog Out

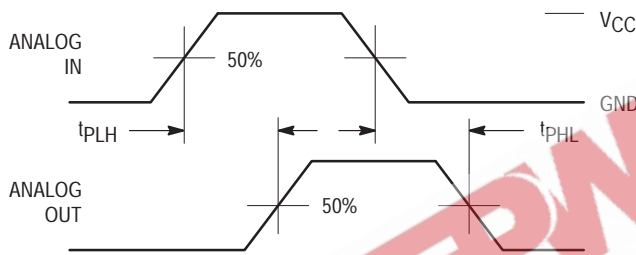
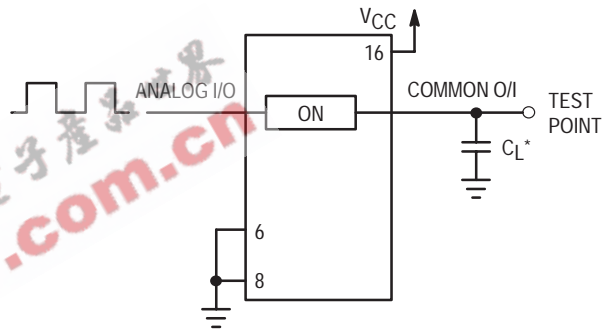

Figure 10a. Propagation Delays, Analog In to Analog Out



*Includes all probe and jig capacitance

Figure 10b. Propagation Delay, Test Set-Up Analog In to Analog Out

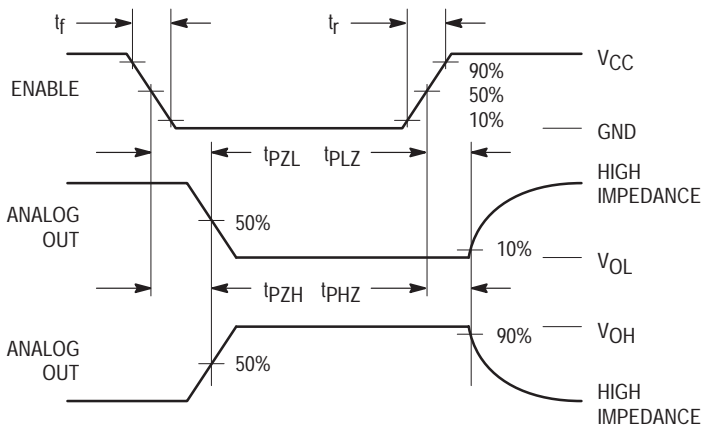

Figure 11a. Propagation Delays, Enable to Analog Out

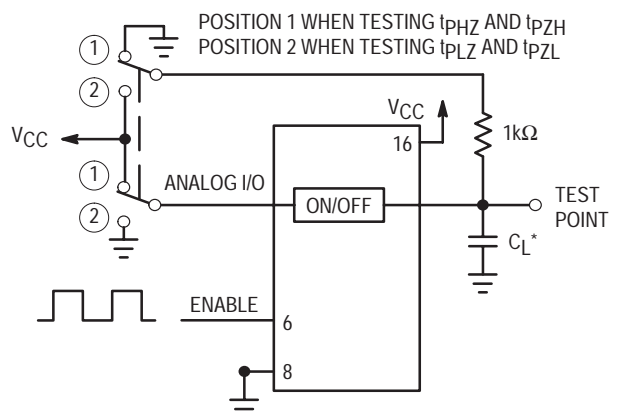
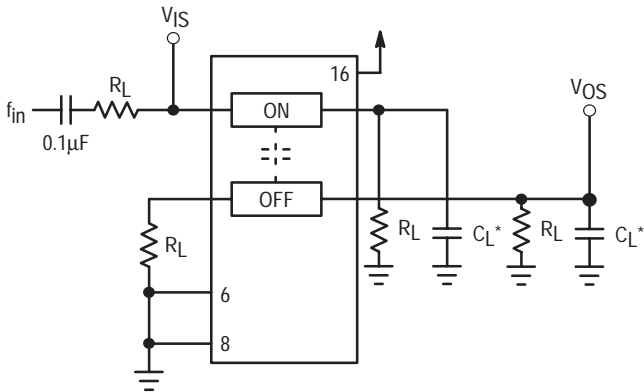

Figure 11b. Propagation Delay, Test Set-Up Enable to Analog Out

MC74LVX8053



*Includes all probe and jig capacitance

Figure 12. Crosstalk Between Any Two Switches, Test Set-Up

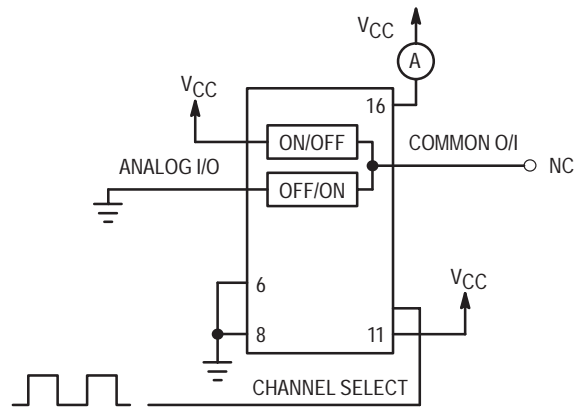
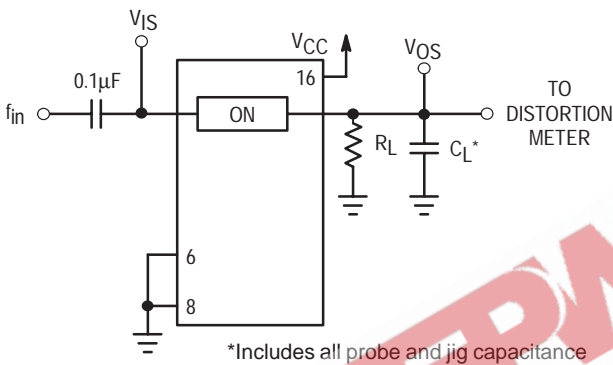

Figure 13. Power Dissipation Capacitance, Test Set-Up



*Includes all probe and jig capacitance

Figure 14a. Total Harmonic Distortion, Test Set-Up

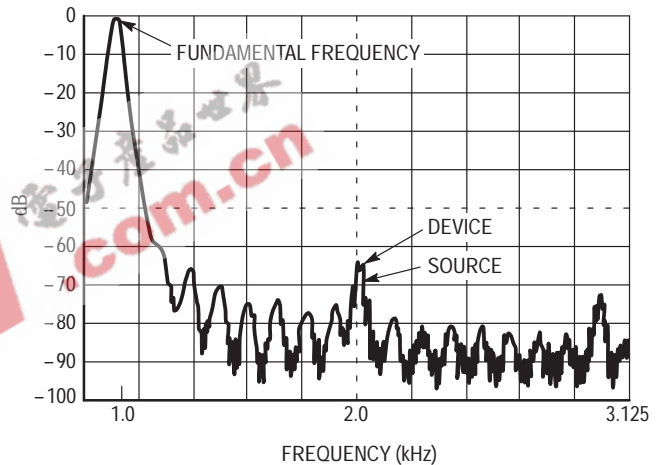

Figure 14b. Plot, Harmonic Distortion

APPLICATIONS INFORMATION

The Channel Select and Enable control pins should be at V_{CC} or GND logic levels. V_{CC} being recognized as a logic high and GND being recognized as a logic low. In this example:

$$\begin{aligned} V_{CC} &= +5V = \text{logic high} \\ GND &= 0V = \text{logic low} \end{aligned}$$

The maximum analog voltage swing is determined by the supply voltages V_{CC} . The positive peak analog voltage should not exceed V_{CC} . Similarly, the negative peak analog voltage should not go below GND. In this example, the difference between V_{CC} and GND is five volts. Therefore, using the configuration of Figure 15, a maximum analog signal of five volts peak-to-peak can be controlled. Unused analog inputs/outputs may be left floating (i.e., not

connected). However, tying unused analog inputs and outputs to V_{CC} or GND through a low value resistor helps minimize crosstalk and feedthrough noise that may be picked up by an unused switch.

Although used here, balanced supplies are not a requirement. The only constraints on the power supplies are that:

$$V_{CC} - GND = 2 \text{ to } 6 \text{ volts}$$

When voltage transients above V_{CC} and/or below GND are anticipated on the analog channels, external Germanium or Schottky diodes (D_X) are recommended as shown in Figure 16. These diodes should be able to absorb the maximum anticipated current surges during clipping.

MC74LVX8053

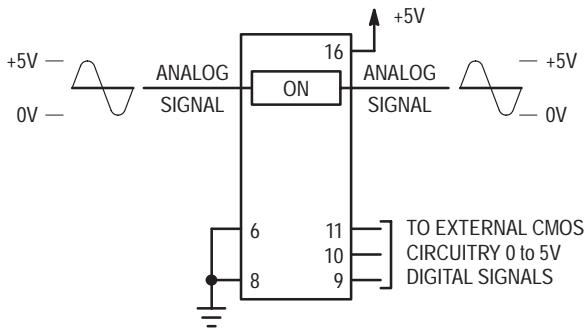

Figure 15. Application Example

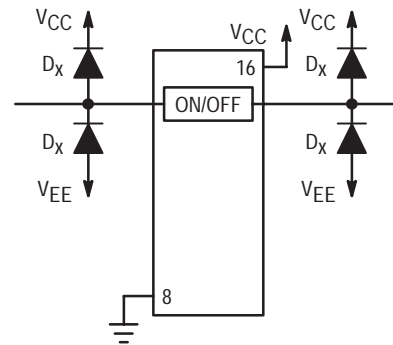
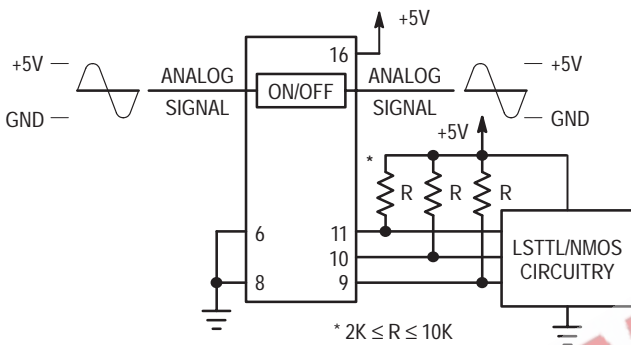
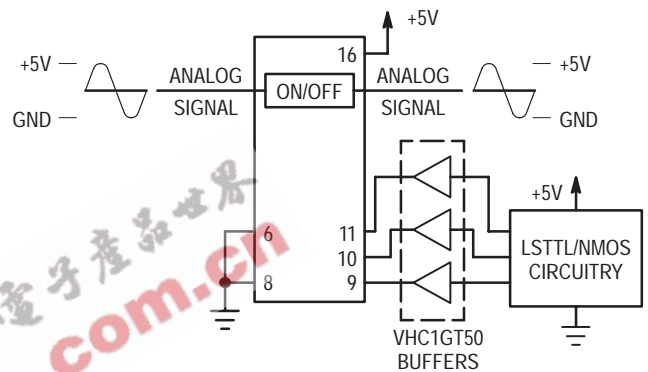

Figure 16. External Germanium or Schottky Clipping Diodes



a. Using Pull-Up Resistors



b. Using HCT Interface

Figure 17. Interfacing LSTTL/NMOS to CMOS Inputs

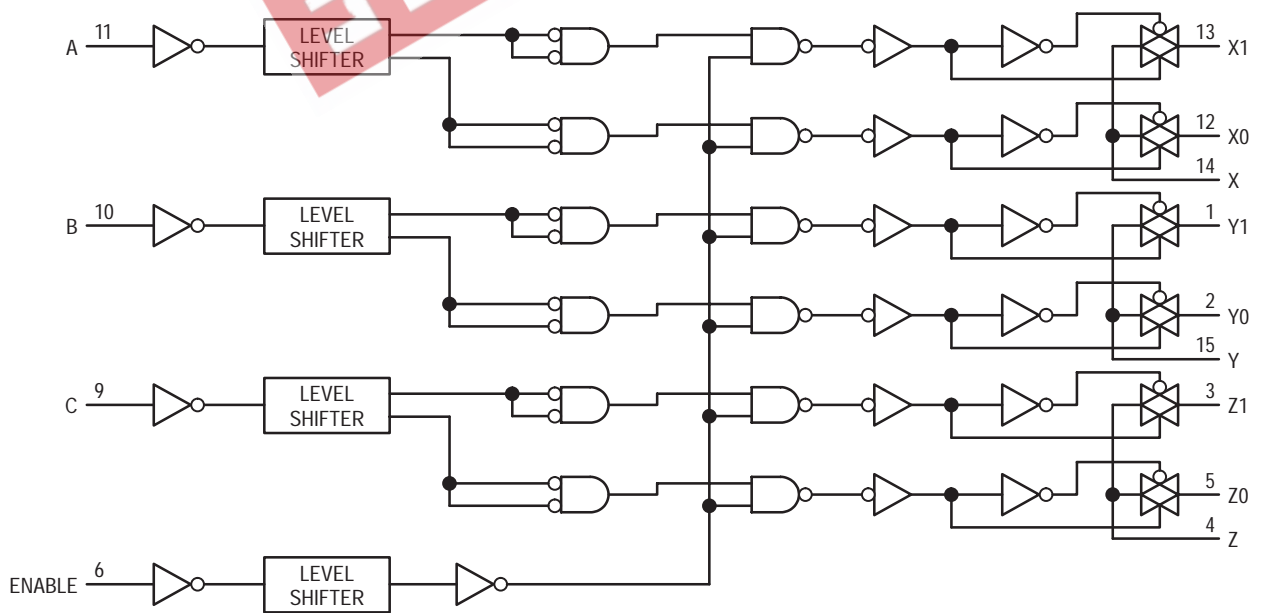
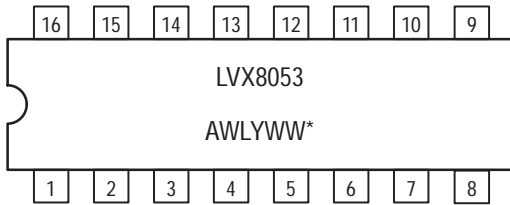

Figure 18. Function Diagram, LVX8053

MC74LVX8053

MARKING DIAGRAMS (Top View)



16-LEAD SOIC
D SUFFIX
CASE 751B

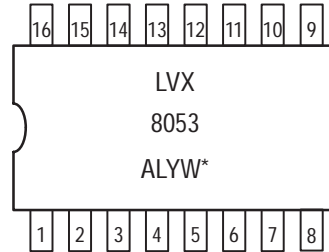

16-LEAD TSSOP
DT SUFFIX
CASE 948F

*See Applications Note #AND8004/D for date code and traceability information.

PACKAGE DIMENSIONS

D SUFFIX PLASTIC SOIC PACKAGE CASE 751B-05 ISSUE J

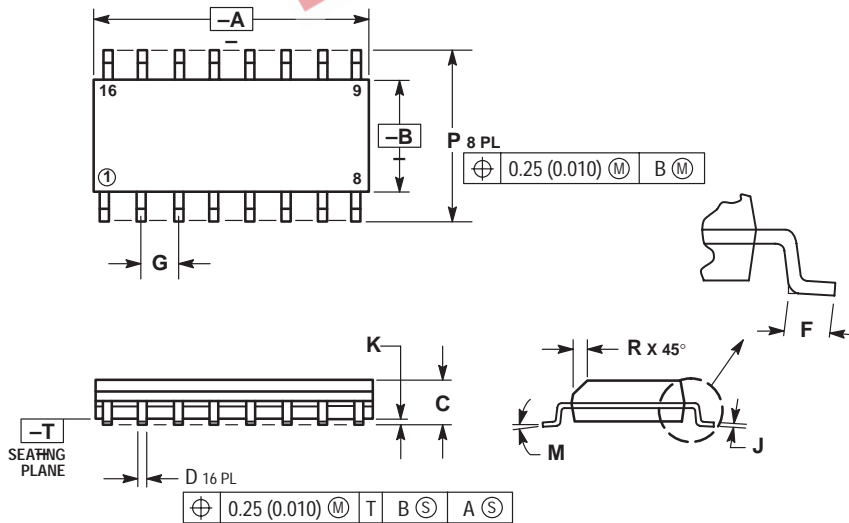

NOTES:

1. DIMENSIONING AND TOLERANCING PER ANSI Y14.5M, 1982.
2. CONTROLLING DIMENSION: MILLIMETER.
3. DIMENSIONS A AND B DO NOT INCLUDE MOLD PROTRUSION.
4. MAXIMUM MOLD PROTRUSION 0.15 (0.006) PER SIDE.
5. DIMENSION D DOES NOT INCLUDE DAMBAR PROTRUSION. ALLOWABLE DAMBAR PROTRUSION SHALL BE 0.127 (0.005) TOTAL IN EXCESS OF THE D DIMENSION AT MAXIMUM MATERIAL CONDITION.

DIM	MILLIMETERS		INCHES	
	MIN	MAX	MIN	MAX
A	9.80	10.00	0.386	0.393
B	3.80	4.00	0.150	0.157
C	1.35	1.75	0.054	0.068
D	0.35	0.49	0.014	0.019
F	0.40	1.25	0.016	0.049
G	1.27 BSC		0.050 BSC	
J	0.19	0.25	0.008	0.009
K	0.10	0.25	0.004	0.009
M	0°	7°	0°	7°
P	5.80	6.20	0.229	0.244
R	0.25	0.50	0.010	0.019

MC74LVX8053

PACKAGE DIMENSIONS

DT SUFFIX
PLASTIC TSSOP PACKAGE
CASE 948F-01
ISSUE O

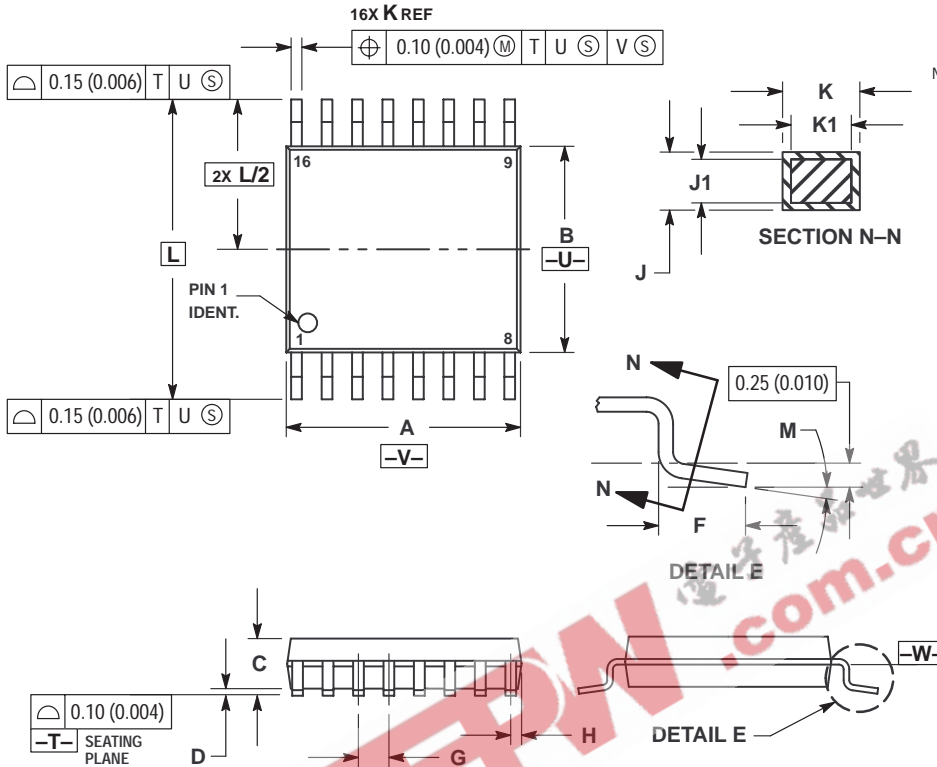

- NOTES:
- DIMENSIONING AND TOLERANCING PER ANSI Y14.5M, 1982.
 - CONTROLLING DIMENSION: MILLIMETER.
 - DIMENSION A DOES NOT INCLUDE MOLD FLASH, PROTRUSIONS OR GATE BURRS. MOLD FLASH OR GATE BURRS SHALL NOT EXCEED $0.15 (0.006)$ PER SIDE.
 - DIMENSION B DOES NOT INCLUDE INTERLEAD FLASH OR PROTRUSION. INTERLEAD FLASH OR PROTRUSION SHALL NOT EXCEED $0.25 (0.010)$ PER SIDE.
 - DIMENSION K DOES NOT INCLUDE DAMBAR PROTRUSION. ALLOWABLE DAMBAR PROTRUSION SHALL BE $0.08 (0.003)$ TOTAL IN EXCESS OF THE K DIMENSION AT MAXIMUM MATERIAL CONDITION.
 - TERMINAL NUMBERS ARE SHOWN FOR REFERENCE ONLY.
 - DIMENSION A AND B ARE TO BE DETERMINED AT DATUM PLANE -W-.

DIM	MILLIMETERS		INCHES	
	MIN	MAX	MIN	MAX
A	4.90	5.10	0.193	0.200
B	4.30	4.50	0.169	0.177
C	—	1.20	—	0.047
D	0.05	0.15	0.002	0.006
F	0.50	0.75	0.020	0.030
G	0.65 BSC		0.026 BSC	
H	0.18	0.28	0.007	0.011
J	0.09	0.20	0.004	0.008
J1	0.09	0.16	0.004	0.006
K	0.19	0.30	0.007	0.012
K1	0.19	0.25	0.007	0.010
L	6.40 BSC		0.252 BSC	
M	0°	8°	0°	8°

ON Semiconductor and are trademarks of Semiconductor Components Industries, LLC (SCILLC). SCILLC reserves the right to make changes without further notice to any products herein. SCILLC makes no warranty, representation or guarantee regarding the suitability of its products for any particular purpose, nor does SCILLC assume any liability arising out of the application or use of any product or circuit, and specifically disclaims any and all liability, including without limitation special, consequential or incidental damages. "Typical" parameters which may be provided in SCILLC data sheets and/or specifications can and do vary in different applications and actual performance may vary over time. All operating parameters, including "Typicals" must be validated for each customer application by customer's technical experts. SCILLC does not convey any license under its patent rights nor the rights of others. SCILLC products are not designed, intended, or authorized for use as components in systems intended for surgical implant into the body, or other applications intended to support or sustain life, or for any other application in which the failure of the SCILLC product could create a situation where personal injury or death may occur. Should Buyer purchase or use SCILLC products for any such unintended or unauthorized application, Buyer shall indemnify and hold SCILLC and its officers, employees, subsidiaries, affiliates, and distributors harmless against all claims, costs, damages, and expenses, and reasonable attorney fees arising out of, directly or indirectly, any claim of personal injury or death associated with such unintended or unauthorized use, even if such claim alleges that SCILLC was negligent regarding the design or manufacture of the part. SCILLC is an Equal Opportunity/Affirmative Action Employer.

PUBLICATION ORDERING INFORMATION

NORTH AMERICA Literature Fulfillment:

Literature Distribution Center for ON Semiconductor
P.O. Box 5163, Denver, Colorado 80217 USA
Phone: 303-675-2175 or 800-344-3860 Toll Free USA/Canada
Fax: 303-675-2176 or 800-344-3867 Toll Free USA/Canada
Email: ONlit@hibbertco.com
Fax Response Line: 303-675-2167 or 800-344-3810 Toll Free USA/Canada

N. American Technical Support: 800-282-9855 Toll Free USA/Canada

EUROPE: LDC for ON Semiconductor – European Support

German Phone: (+1) 303-308-7140 (M-F 1:00pm to 5:00pm Munich Time)
Email: ONlit-german@hibbertco.com
French Phone: (+1) 303-308-7141 (M-F 1:00pm to 5:00pm Toulouse Time)
Email: ONlit-french@hibbertco.com
English Phone: (+1) 303-308-7142 (M-F 12:00pm to 5:00pm UK Time)
Email: ONlit@hibbertco.com

EUROPEAN TOLL-FREE ACCESS*: 00-800-4422-3781

*Available from Germany, France, Italy, England, Ireland

CENTRAL/SOUTH AMERICA:

Spanish Phone: 303-308-7143 (Mon-Fri 8:00am to 5:00pm MST)
Email: ONlit-spanish@hibbertco.com

ASIA/PACIFIC: LDC for ON Semiconductor – Asia Support

Phone: 303-675-2121 (Tue-Fri 9:00am to 1:00pm, Hong Kong Time)
Toll Free from Hong Kong & Singapore:
001-800-4422-3781
Email: ONlit-asia@hibbertco.com

JAPAN: ON Semiconductor, Japan Customer Focus Center

4-32-1 Nishi-Gotanda, Shinagawa-ku, Tokyo, Japan 141-8549
Phone: 81-3-5740-2745
Email: r14525@onsemi.com

ON Semiconductor Website: <http://onsemi.com>

For additional information, please contact your local Sales Representative.