



4-BIT BIDIRECTIONAL UNIVERSAL SHIFT REGISTER

The MC74F194 is a high-speed 4-bit bidirectional universal shift register. As a high-speed multifunctional, sequential building block, it is useful in a wide variety of applications. It may be used in serial-serial, shift left, shift right, serial-parallel, parallel-serial, and parallel-parallel data register transfers. The F194 is similar in operation to the S195 universal shift register, with added features of shift left without external connections and hold (do nothing) modes of operation.

- Typical Shift Frequency of 150 MHz
- Asynchronous Master Reset
- Hold (Do Nothing) Mode
- Fully Synchronous Serial or Parallel Data Transfers

FUNCTIONAL DESCRIPTION

The F194 contains four edge-triggered D flip-flops and the necessary interstage logic to synchronously perform shift right, shift left, parallel load and hold operations. Signals applied to the Select (S_0 , S_1) inputs determine the type of operation, as shown in the Function Table. Signals on the Select, Parallel data (P_0 – P_3) and Serial data (DSR , DSL) inputs can change when the clock is in either state, provided only that the recommended setup and hold times, with respect to the clock rising edge, are observed. A LOW signal on Master Reset (\overline{MR}) overrides all other inputs and forces the outputs LOW.

CONNECTION DIAGRAM

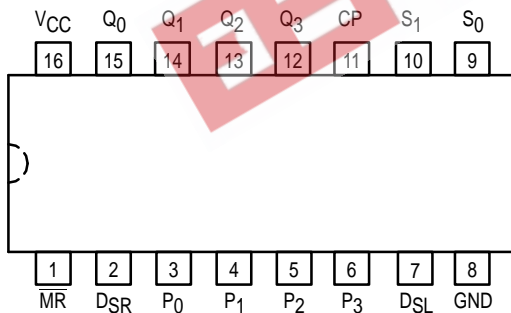

FUNCTION TABLE

Operating Mode	Inputs						Outputs			
	MR	S ₁	S ₀	DSR	DSL	P _n	Q ₀	Q ₁	Q ₂	Q ₃
Reset	L	X	X	X	X	X	L	L	L	L
Hold	H	l	l	X	X	X	q ₀	q ₁	q ₂	q ₃
Shift Left	H	h	l	X	l	X	q ₁	q ₂	q ₃	L
	H	h	l	X	h	X	q ₁	q ₂	q ₃	H
Shift Right	H	l	h	l	X	X	L	q ₀	q ₁	q ₂
	H	l	h	h	X	X	H	q ₀	q ₁	q ₂
Parallel Load	H	h	h	X	X	p _n	p ₀	p ₁	p ₂	p ₃

l = LOW voltage level one setup time prior to the LOW-to-HIGH clock transition.
h = HIGH voltage level one setup time prior to the LOW-to-HIGH clock transition.
p_n, q_n = Lower case letters indicate the state of the referenced input or output one setup time prior to the LOW-to-HIGH clock transition.
H = HIGH Voltage Level
L = LOW Voltage Level
X = Immaterial

MC74F194

4-BIT BIDIRECTIONAL UNIVERSAL SHIFT REGISTER

FAST™ SCHOTTKY TTL

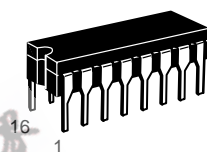

J SUFFIX
CERAMIC
CASE 620-09

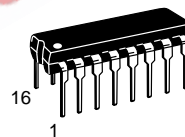

N SUFFIX
PLASTIC
CASE 648-08

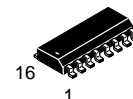

D SUFFIX
SOIC
CASE 751B-03

ORDERING INFORMATION

MC74FXXXJ Ceramic
MC74FXXXN Plastic
MC74FXXXD SOIC

LOGIC SYMBOL

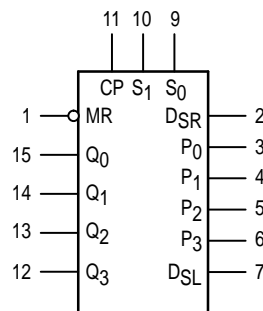

V_{CC} = PIN 16
GND = PIN 8

MC74F194

LOGIC DIAGRAM

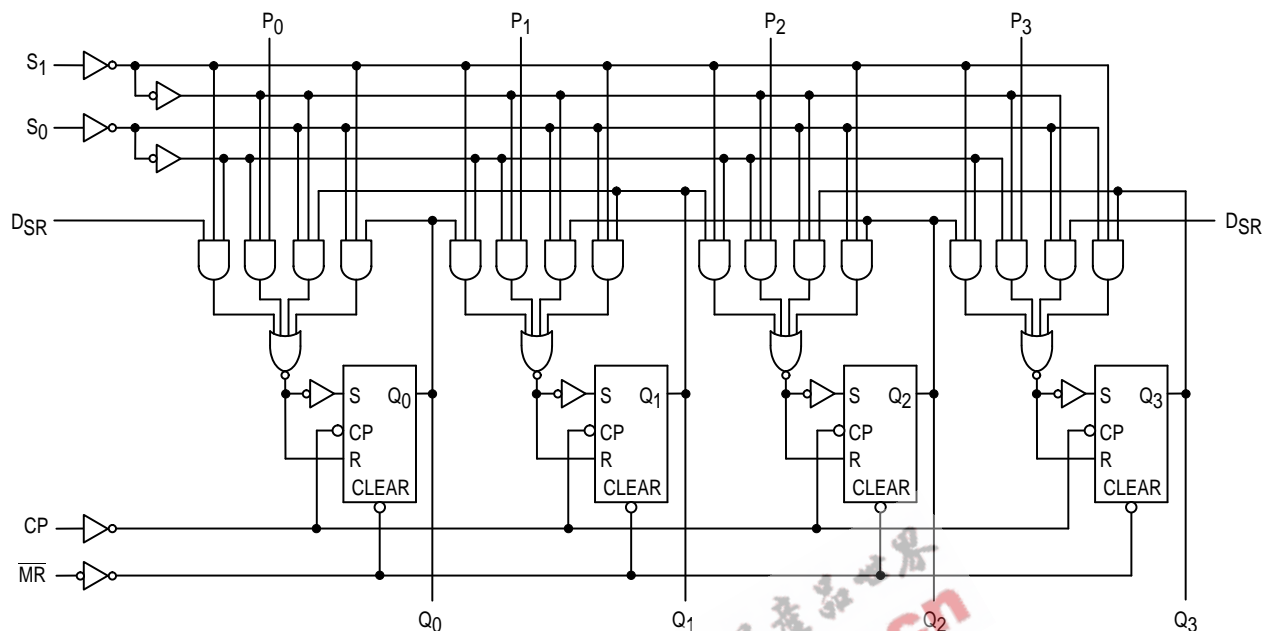

Please note that this diagram is provided only for the understanding of logic operations and should not be used to estimate propagation delays.

GUARANTEED OPERATING RANGES

Symbol	Parameter	74	Min	Typ	Max	Unit
V _{CC}	Supply Voltage	74	4.5	5.0	5.5	V
T _A	Operating Ambient Temperature Range	74	0	25	70	°C
I _{OH}	Output Current — High	74			-1.0	mA
I _{OL}	Output Current — Low	74			20	mA

DC CHARACTERISTICS OVER OPERATING TEMPERATURE RANGE (unless otherwise specified)

Symbol	Parameter	Limits			Unit	Test Conditions
		Min	Typ	Max		
V _{IH}	Input HIGH Voltage	2.0			V	Guaranteed Input HIGH Voltage
V _{IL}	Input LOW Voltage			0.8	V	Guaranteed Input LOW Voltage
V _{IK}	Input Clamp Diode Voltage			-1.2	V	I _{IN} = -18 mA V _{CC} = MIN
V _{OH}	Output HIGH Voltage	74	2.5	3.4	V	I _{OH} = -1.0 mA V _{CC} = 4.5 V
		74	2.7	3.4	V	I _{OH} = -1.0 mA V _{CC} = 4.75 V
V _{OL}	Output LOW Voltage		0.35	0.5	V	I _{OL} = 20 mA V _{CC} = MIN
I _{IH}	Input HIGH Current			20	μA	V _{IN} = 2.7 V V _{CC} = MAX
				100	μA	V _{IN} = 7.0 V
I _{IL}	Input LOW Current			-0.6	mA	V _{IN} = 0.5 V V _{CC} = MAX
I _{OS}	Output Short Circuit Current (Note 2)	-60		-150	mA	V _{OUT} = 0 V V _{CC} = MAX
I _{CC}	Power Supply Current		33	46	mA	S _n , MR, DSR, D _{SL} = 4.5 V P _n = Gnd, CP = ⌋

NOTES:

- For conditions such as MIN or MAX, use the appropriate value specified under guaranteed operating ranges.
- Not more than one output should be shorted at a time, nor for more than 1 second.

MC74F194

AC CHARACTERISTICS

Symbol	Parameter	74F		74F		Unit
		T _A = +25°C V _{CC} = +5.0 V C _L = 50 pF		T _A = 0 to +70°C V _{CC} = 5.0 V ±10% C _L = 50 pF		
		Min	Max	Min	Max	
f _{max}	Maximum Shift Frequency	105		90		MHz
t _{PLH} t _{PHL}	Propagation Delay CP to Q _N	3.0 3.5	7.0 7.5	3.5 3.5	8.0 8.0	ns
t _{PHL}	Propagation Delay MR to Q _N	4.5	12	4.5	14	ns

AC OPERATING REQUIREMENTS

Symbol	Parameter	74F		74F		Unit
		T _A = +25°C V _{CC} = +5.0 V		T _A = 0 to +70°C V _{CC} = 5.0 V ±10%		
		Min	Max	Min	Max	
t _s (H) t _s (L)	Set up Time, HIGH or LOW P _N or D _{SR} or D _{SL} to CP	4.0 4.0		4.0 4.0		ns
t _h (H) t _h (L)	Hold Time, HIGH or LOW P _N or D _{SR} or D _{SL} to CP	0 0		1.0 1.0		
t _s (H) t _s (L)	Set up Time, HIGH or LOW S _N to CP	8.0 8.0		9.0 8.0		ns
t _h (H) t _h (L)	Hold Time, HIGH or LOW S _N to CP	0 0		0 0		
t _w (H)	CP Pulse Width HIGH	5.0		5.5		ns
t _w (L)	$\overline{\text{MR}}$ Pulse Width LOW	5.0		5.0		ns
t _{rec}	Recovery Time $\overline{\text{MR}}$ to CP	7.0		8.0		ns