



M-FIAM5

Military 28Vin Filter Input Attenuator Module



Shown actual size:
2.28 x 2.2 x 0.5 in
57,9 x 55,9 x 12,7 mm

Features

- EMI filtering-MIL-STD-461E
- Transient protection-MIL-STD-704E¹
- Environments-MIL-STD-810, MIL-STD-202
- Environmental stress screening
- Low profile mounting options
- Output current up to 20 Amps
- Mini sized package
- Inrush current limiting
- Reverse polarity protection

Product Highlights

The M-FIAM5 is a DC front-end module that provides EMI filtering and transient protection required in military applications. The M-FIAM5 enables designers using Vicor 2nd Generation 24V DC-DC converters to meet conducted emission/conducted susceptibility per MIL-STD-461E; and input transients per MIL-STD-704E¹. The M-FIAM5 accepts an input voltage of 18-36Vdc and delivers output current up to 20 Amps.

M-FIAM5 is housed in an industry standard "half brick" module measuring 2.28" x 2.2" x 0.5" and depending upon model selected, may be mounted on-board or in-board for height critical applications.

Compatible Products

- 2nd Generation 24V Input DC-DC converters

Part Number Format

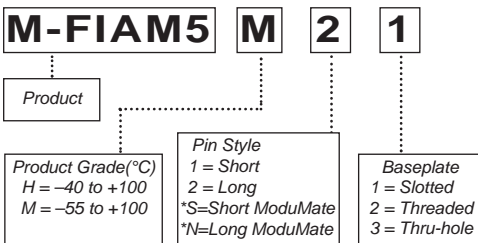

^{*}Compatible with SurfMate and InMate socketing system.

Thermal Resistance

Parameter	Typ
Baseplate to sink; flat, greased surface	0.16°C/Watt
Baseplate to sink; thermal pad (P/N 20264)	0.1°C/Watt
Baseplate to ambient	7.9°C/Watt
Baseplate to sink; 1000 LFM	2.2°C/Watt

Absolute Maximum Rating

Parameter	Rating	Unit	Notes
+In to -In	36	Vdc	Continuous
+In to -In	50	Vdc	100ms
Mounting torque	5(0.57)	in-lbs	6 each, #4-40 or M3
Pin Soldering temperature	500 (260)	°F(°C)	<5 sec; wave solder
Pin Soldering temperature	750 (390)	°F(°C)	<7 sec; hand solder
Operating temperature H-Grade	-40 to +100	°C	Baseplate
Storage temperature H-Grade	-55 to +125	°C	
Operating temperature M-Grade	-55 to +100	°C	Baseplate
Storage temperature M-Grade	-65 to +125	°C	

Specifications

(typical at TBP = 25°C, nominal line, 75% load, unless otherwise specified)

Parameter	Min	Typ	Max	Remarks
Input voltage	18Vdc	28Vdc	36Vdc	Continuous
Output current			20A	
Inrush limiting			0.007A/μF	
Transient immunity	MIL-STD-704E			See footnote 1
EMI:MIL-STD-461E				
Conducted emissions:	CE101, CE102			
Conducted susceptibility:	CS101, CS114, CS115, CS116			
Dielectric withstand		1,500Vrms 2,121Vdc		Input/Output to Base Input/Output to Base
Efficiency	96%	98%		
Internal voltage drop		0.5	1.0	@20A, 100°C baseplate
ON/OFF control				
Enable (ON)	0.0Vdc		1.0Vdc	Referenced to -Vout.
Disable (OFF)	3.5Vdc		5.0Vdc	100kΩ internal pull-up resistor
External capacitance		330μF	1000μF	See illustration C1 on page 3.
Weight		3.1 (88)	4 (113)	Ounces (grams)
Warranty			2	Years

¹ MIL-STD-704E Compliance requires an external circuit. See addendum A

MTBF per MIL-HDBK-217F

Temp	Environment	MTBF	Unit
25°C	Ground Benign:G.B.	3,334,295	Hrs
50°C	Naval Sheltered:N.S.	786,893	Hrs
65°C	Airborne Inhabited Cargo:A.I.C.	650,187	Hrs

Environmental Qualification

Altitude	MIL-STD-810C, Method 500.2, Procedure I & II, 40,000 ft. and 70,000 ft. Operational.
Explosive Atmosphere	MIL-STD-810F, Method 511.4, Procedure I, Operational.
Vibration	MIL-STD-810F, Method 514.5, Procedure I, Category 14, Sine and Random vibration per Table 514.5C for Helicopter AH-6J Main Rotor with overall level of 5.6 grams for 4 hours per axis. MIL-STD-810F, Method 514.5C, General Minimum Integrity Curve per Figure 514.5C-17 with overall level of 7.7 grams for 1 hour per axis.
Shock	MIL-STD-810-F, Method 516.5, Procedure I, Functional Shock, 40 G's. MIL-S-901D, Lightweight Hammer Shock, 3 impacts/axis, 1,3,5 ft. MIL-STD-202F, Method 213B, 60 G's, 9ms half sine. MIL-STD-202F, Method 213B, 75 G's, 11ms Saw Tooth Shock.
Acceleration	MIL-STD-810F, Method 513.5, Procedure II, table 513.5-II, Operational, 2-7 G's, 6 directions.
Humidity	MIL-STD-810F, Method 507.4, Procedure I, Cycle I, 240 hrs, 95% RH.
Solder Test	MIL-STD-202F, Method 208, 8 hour aging.

Environmental Stress Screening

	H Grade	M Grade
Operating Temp.	-40°C to +100°C	-55°C to +100°C
Storage Temp.	-55°C to +125°C	-65°C to +125°C
Temp. Cycling:*	12 cycles -65°C to +100°C	12 cycles -65°C to +100°C
Ambient Test @ 25°C	Yes	Yes
Power Cycling Burn-In:	12 hours, 28 cycles	24 hours, 56 cycles
Functional and Parametric ATE Tests:	-40°C and +100°C	-55°C and +100°C
Hi-Pot Test	Yes	Yes
Visual Inspection:	Yes	Yes
Test Data	vicorpower.com	vicorpower.com

*Temperature cycled with power off, 17°C per minute rate of change.

Conducted Noise

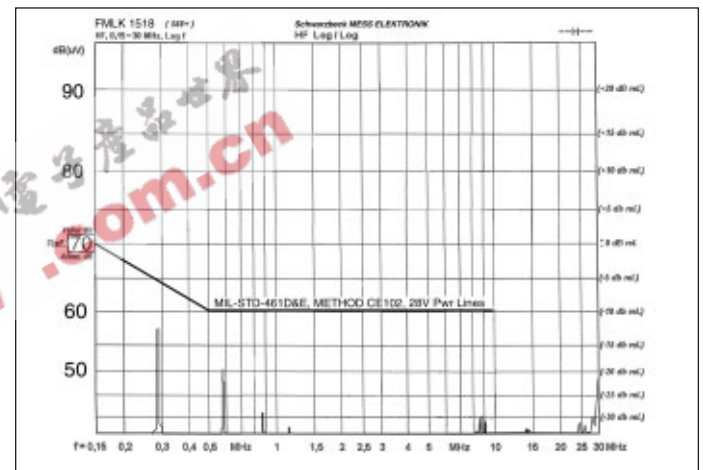

Figure 1– M-FIAM5 and Model V24A12M400A DC-DC converter operating at 28Vdc, 400W.

Transient Immunity

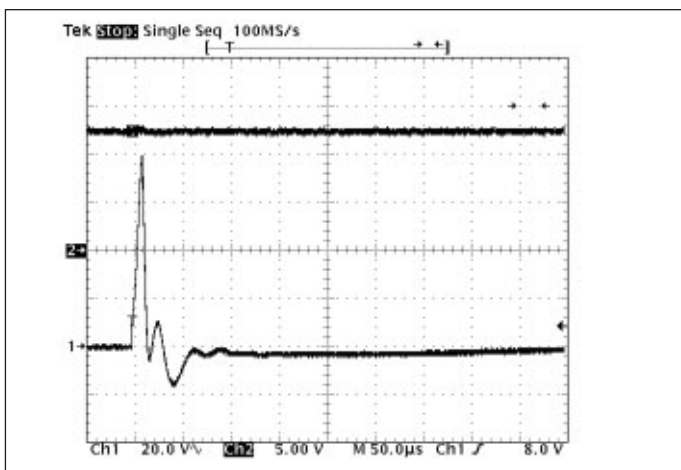

Figure 2 – Transient Immunity: M-FIAM5 output response to an input transient.

Inrush Limiting

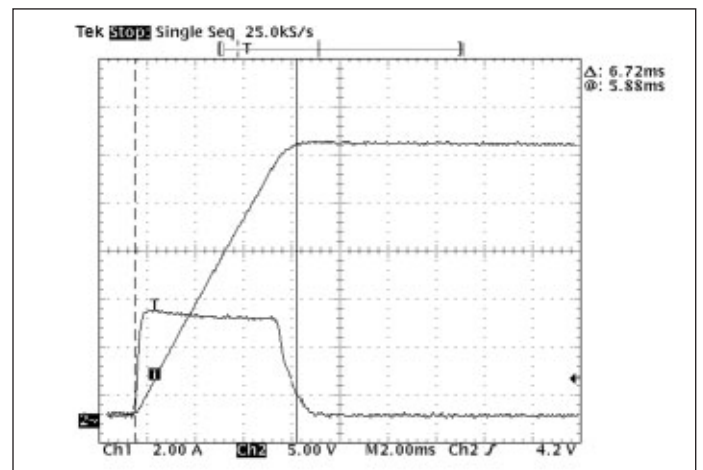
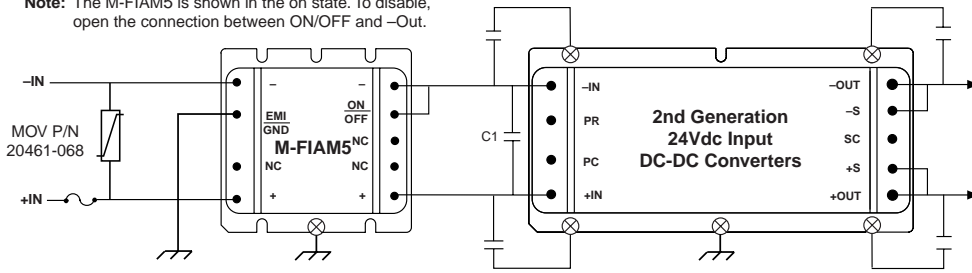

Figure 3– Inrush Limiting: Inrush current with 1000µF external capacitance.

Transient and Surge Protection

Note: The M-FIAM5 is shown in the on state. To disable, open the connection between ON/OFF and -Out.



Capacitance (C1)
330µF(min), 1000µF(max)
Recommended Fuse:
20A Max., F03A Type

Mechanical Diagram

Module Pins		
No.	Function	Label
1	+In	+
2	No Connection	NC
3	Ground	EMI/GND
4	-In	-
5	-Out	-
6	ON/OFF	ON/OFF
7	No Connection	NC
8	No Connection	NC
9	+Out	+

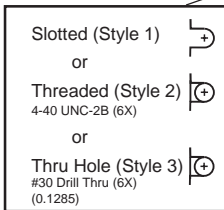
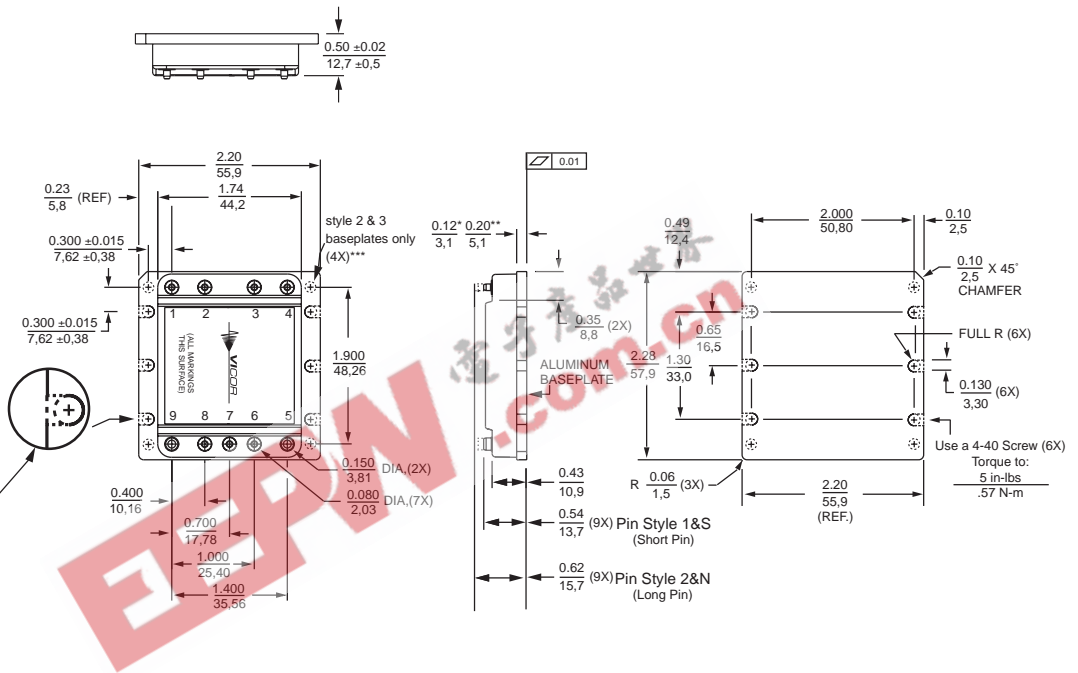

* Style 1 baseplate only
** Style 2 & 3 baseplates
*** Reserved for Vicor accessories
Not for mounting

PCB Mounting Specifications

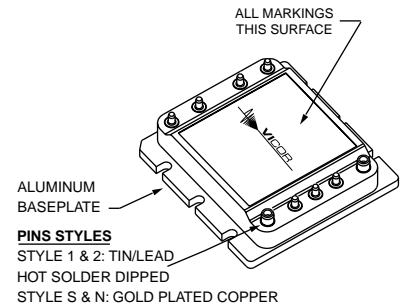
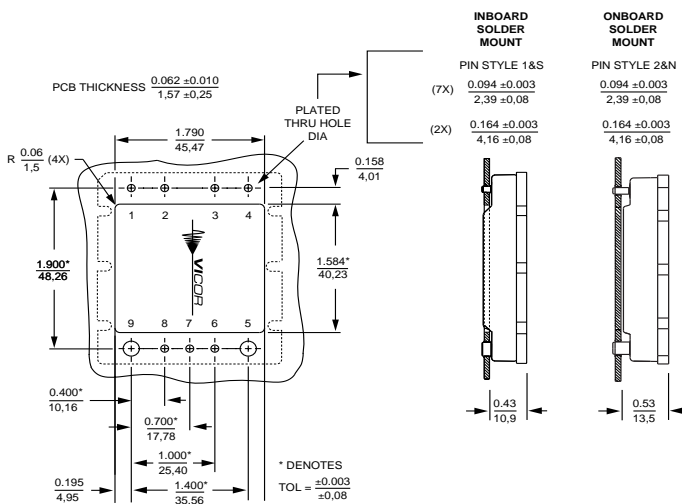

Addendum A

MIL-STD-704E Transient / Overvoltage Protection

The standard (COTS) 24V input 2nd Generation Converter Modules may be used in Military 28 volt applications. The M-FIAM5 provides compliance to MIL-STD-461E conducted emissions and susceptibility standards. Additional circuitry, as illustrated in the accompanying schematic (see Fig. 1), provides compliance to the MIL-STD-704E transient overvoltage specification. The 24V input modules employ undervoltage and overvoltage protection. These converters, shut down if the input falls below 18V or rises to 36V or above. 18V is consistent with the MIL-STD-704E specification, but the standard also requires uninterrupted performance in the event of an input voltage transient to 50V for a period of 12.5 millisecc. The above referenced circuit clamps the input voltage, in the event that it exceeds 32V, as illustrated in figure 2. This performance prevents the converter from shutting down, thus meeting the transient overvoltage specification of MIL- STD-704E.

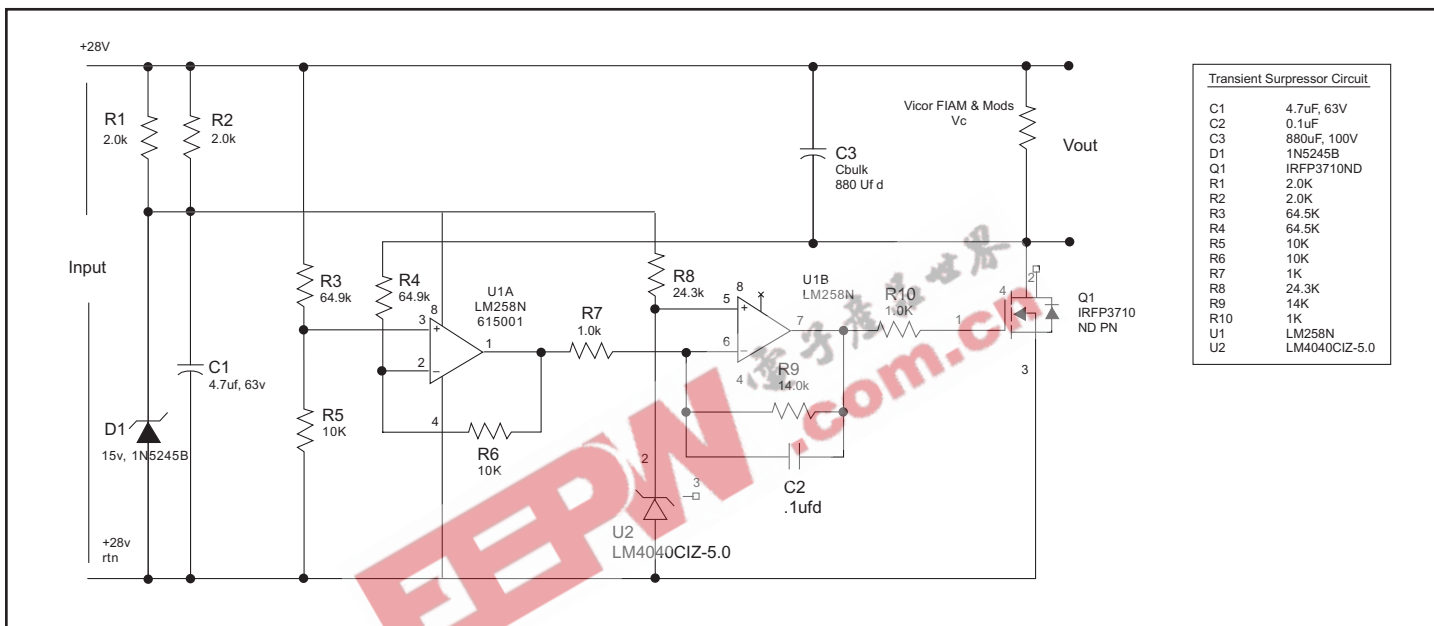

Figure 1– Transient / Overvoltage protection circuit.

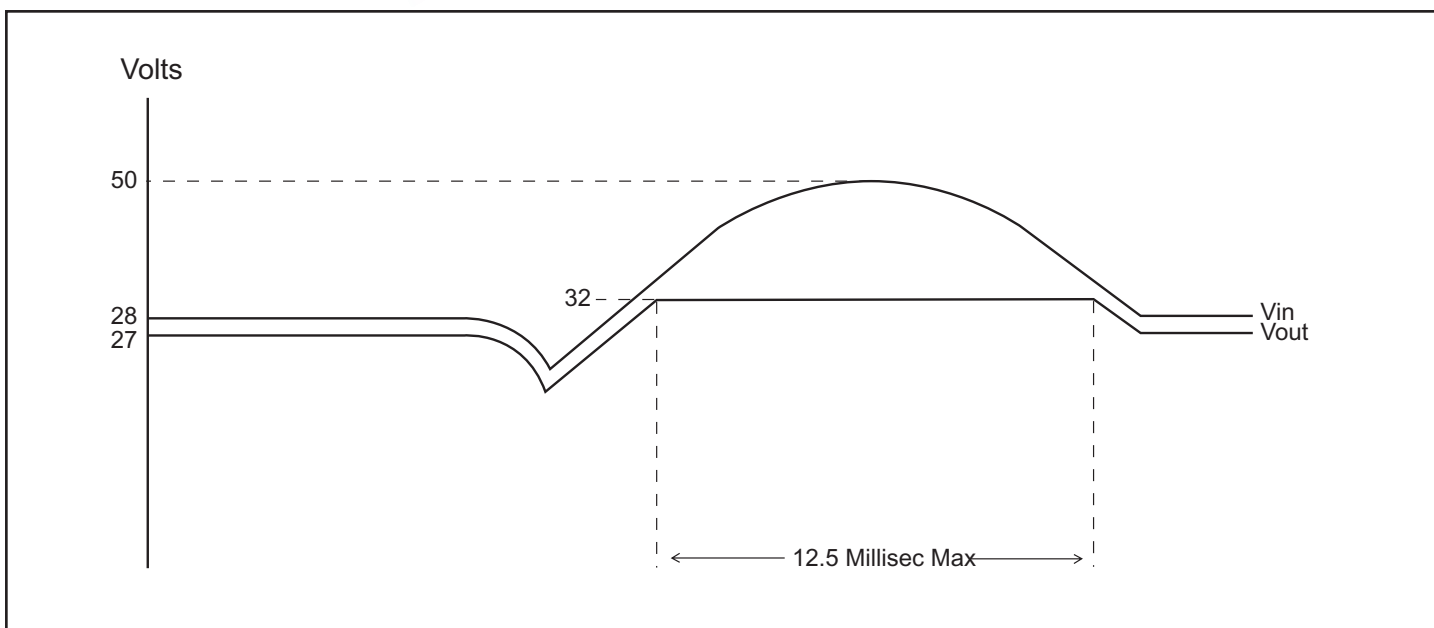

Figure 2– Overvoltage clamping

Vicor's comprehensive line of power solutions includes modular, high density DC-DC converters and accessory components, configurable power supplies, and custom power systems.

Information furnished by Vicor is believed to be accurate and reliable. However, no responsibility is assumed by Vicor for its use. No license is granted by implication or otherwise under any patent or patent rights of Vicor. Vicor components are not designed to be used in applications, such as life support systems, wherein a failure or malfunction could result in injury or death. All sales are subject to Vicor's Terms and Conditions of Sale, which are available upon request.

Specifications are subject to change without notice.



*Component Solutions
for Your Power System*

Vicor Corporation
25 Frontage Road
Andover, MA, USA 01810
Tel: 800-735-6200
978-470-2900
Fax: 978-475-6715

Email

Vicor Express: vicorexp@vicr.com
Technical Support: apps@vicr.com