

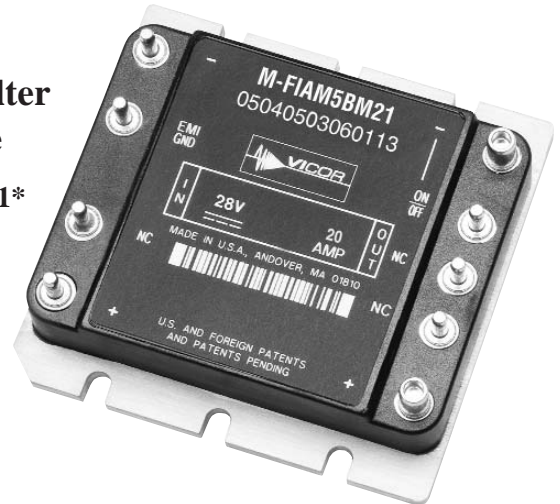

M-FIAM5

Military COTS 28 Vin Filter Input Attenuator Module

Model Number: M-FIAM5BM21*



Shown actual size:
2.28 x 2.2 x 0.5 in
57,9 x 55,9 x 12,7 mm

Features

- EMI filtering-MIL-STD-461E
- Transient protection-MIL-STD-704E/F
- Environments-MIL-STD-810, MIL-STD-202
- Environmental stress screening
- Low profile mounting options
- Output current up to 20 Amps
- Mini sized package
- Inrush current limiting
- Reverse polarity protection

Product Highlights

The M-FIAM5 is a DC front-end module that provides EMI filtering and transient protection. The M-FIAM5 enables designers using Vicor 2nd Generation 24 V DC-DC converters to meet conducted emission/ conducted susceptibility per MIL-STD-461E; and input transients per MIL-STD-704E/F. The M-FIAM5 accepts an input voltage of 18-36 Vdc and delivers output current up to 20 Amps.

M-FIAM5 is housed in an industry standard "half brick" module measuring 2.28" x 2.2" x 0.5" and depending upon model selected, may be mounted onboard or inboard for height critical applications.

Compatible Products

- 2nd Generation 24 V Input DC-DC converters

*Part Number Format

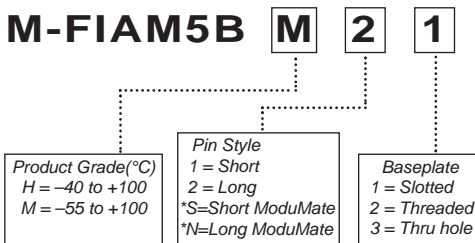

*Compatible with SurfMate and InMate socketing system.

Absolute Maximum Rating

Parameter	Rating	Unit	Notes
+In to -In	36	Vdc	Continuous
+In to -In	50	Vdc	See Fig.1
Mounting torque	5 (0.57)	in-lbs	6 each, #4-40 or M3
Pin soldering temperature	500 (260)	°F(°C)	<5 sec; wave solder
Pin soldering temperature	750 (390)	°F(°C)	<7 sec; hand solder
Operating temperature H-Grade	-40 to +100	°C	Baseplate
Storage temperature H-Grade	-55 to +125	°C	
Operating temperature M-Grade	-55 to +100	°C	Baseplate
Storage temperature M-Grade	-65 to +125	°C	

Specifications

(typical at TBP = 25°C, nominal line, 75% load, unless otherwise specified)

Parameter	Min	Typ	Max	Remarks
Input voltage	18 Vdc	28 Vdc	36 Vdc	Continuous
Output current			20 A	
Inrush limiting			0.007 A/μF	
Transient immunity			50 Vdc	12.5 mS per MIL-STD-704E/F, continuous operation
EMI:MIL-STD-461E				
Conducted emissions: CE101, CE102				
Conducted susceptibility: CS101, CS114, CS115, CS116				
Dielectric withstand		1,500 Vrms 2,121 Vdc		Input/Output to Base Input/Output to Base
Efficiency	96%	98%		
Internal voltage drop		0.5	0.7	@20 A, 100°C baseplate
ON/OFF control				
Enable (ON)	0.0 Vdc		1.0 Vdc	Referenced to -Vout
Disable (OFF)	3.5 Vdc		5.0 Vdc	100 kΩ internal pull-up resistor
External capacitance				See illustration C1 on page 3
		330μF	1000 μF	50 V
Weight		3.3 (94)		Ounces (grams)
Warranty			2	Years

Thermal Resistance

Parameter	Typ
Baseplate to sink; flat, greased surface	0.16°C/Watt
Baseplate to sink; thermal pad (P/N 20264)	0.1°C/Watt
Baseplate to ambient	7.9°C/Watt
Baseplate to ambient; 1000 LFM	2.2°C/Watt

MTBF per MIL-HDBK-217F (M-FIAM5BM21)

Temp	Environment	MTBF	Unit
25°C	Ground Benign: G.B.	2,581	1,000 Hrs
50°C	Naval Sheltered: N.S.	464	1,000 Hrs
65°C	Airborne Inhabited Cargo: A.I.C.	364	1,000 Hrs

Environmental Qualification

Altitude

MIL-STD-810C, Method 500.2, Procedure I & II, 40,000 ft. and 70,000 ft. Operational.

Explosive Atmosphere

MIL-STD-810F, Method 511.4, Procedure I, Operational.

Vibration

MIL-STD-810F, Method 514.5, Procedure I, Category 14, Sine and Random vibration per Table 514.5C for Helicopter AH-6J Main Rotor with overall level of 5.6 grams for 4 hours per axis. MIL-STD-810F, Method 514.5C, General Minimum Integrity Curve per Figure 514.5C-17 with overall level of 7.7 grams for 1 hour per axis.

Shock

MIL-STD-810-F, Method 516.5, Procedure I, Functional Shock, 40 G's. MIL-S-901D, Lightweight Hammer Shock, 3 impacts/axis, 1,3,5 ft. MIL-STD-202F, Method 213B, 60 G's, 9ms half sine. MIL-STD-202F, Method 213B, 75 G's, 11ms Saw Tooth Shock.

Acceleration

MIL-STD-810F, Method 513.5, Procedure II, table 513.5-II, Operational, 2-7 G's, 6 directions.

Humidity

MIL-STD-810F, Method 507.4, Procedure I, Cycle I, 240 hrs, 95% RH.

Solder Test

MIL-STD-202F, Method 208, 8 hour aging.

Shut Down Time vs. Overvoltage

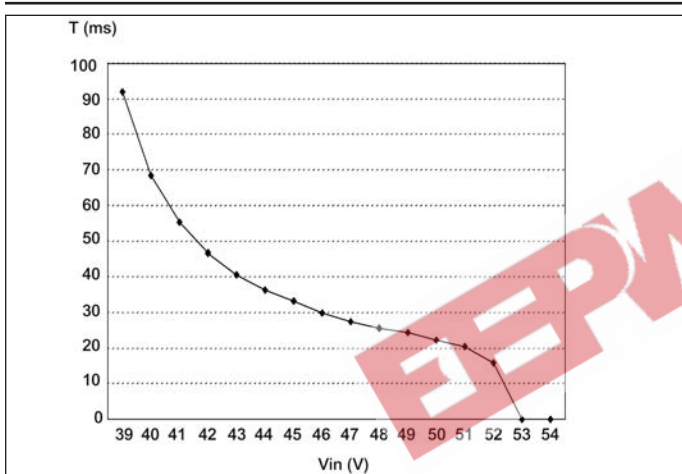

Figure 1– T = Time period before over-voltage protection
Vin = Input voltage (switching up from 28 V)

Conducted Noise

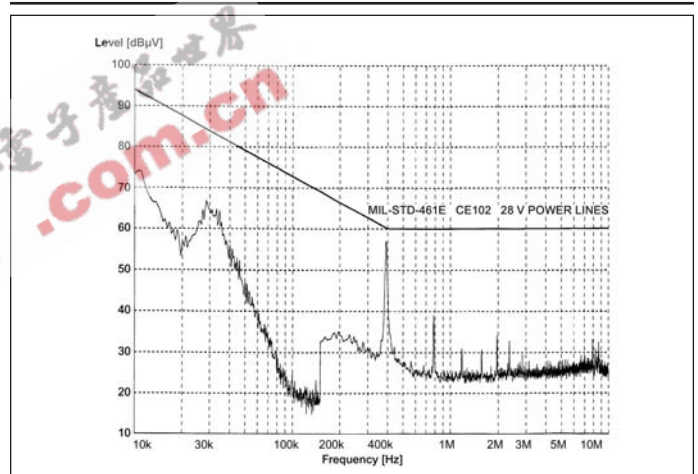

Figure 2– M-FIAM5 and Model V24A12M400A DC-DC converter operating at 28 Vdc, 400 W.

Transient Immunity

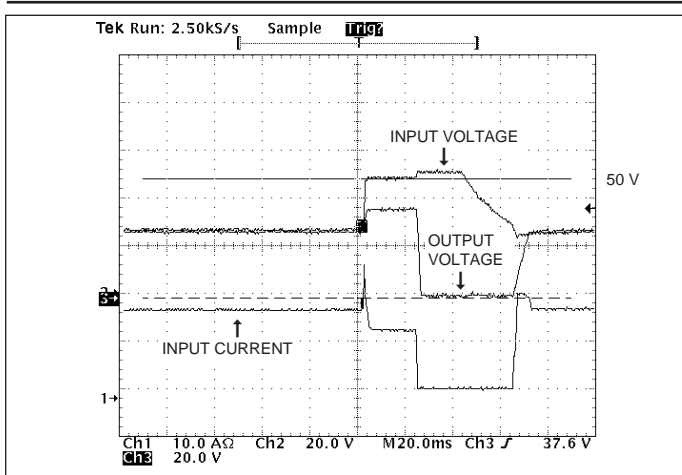

Figure 3 – Transient Immunity: M-FIAM5 output response to an input transient.

Inrush Limiting

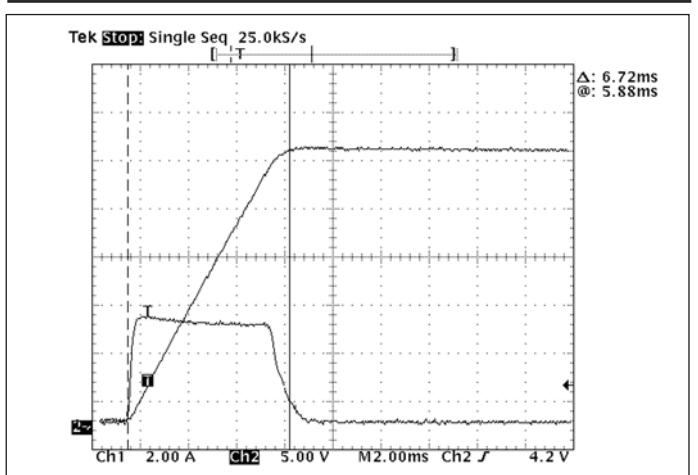

Figure 4– Inrush Limiting: Inrush current with 1000 µF external capacitance.

Environmental Stress Screening

	H Grade	M Grade
Operating temp.	-40°C to +100°C	-55°C to +100°C
Storage temp.	-55°C to +125°C	-65°C to +125°C
Temp. cycling:*	12 cycles -65°C to +100°C	12 cycles -65°C to +100°C
Ambient test @ 25°C	Yes	Yes
Power cycling	12 hours,	24 hours,
Burn-In:	28 cycles	56 cycles
Functional and parametric ATE tests:	-40°C and +100°C	-55°C and +100°C
Hi-Pot test	Yes	Yes
Visual inspection:	Yes	Yes
Test data	vicorpower.com	vicorpower.com

*Temperature cycled with power off, 17°C per minute rate of change.

Transient and Surge Protection

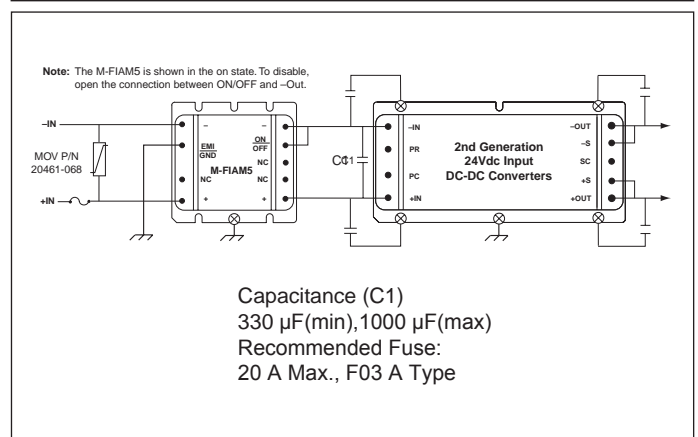

Mechanical Diagram

No.	Function	Label
1	+In	+
2	No Connection	NC
3	Ground	EMI/GND
4	-In	-
5	-Out	-
6	ON/OFF	ON/OFF
7	No Connection	NC
8	No Connection	NC
9	+Out	+

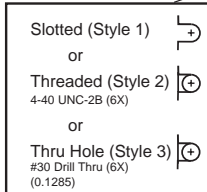
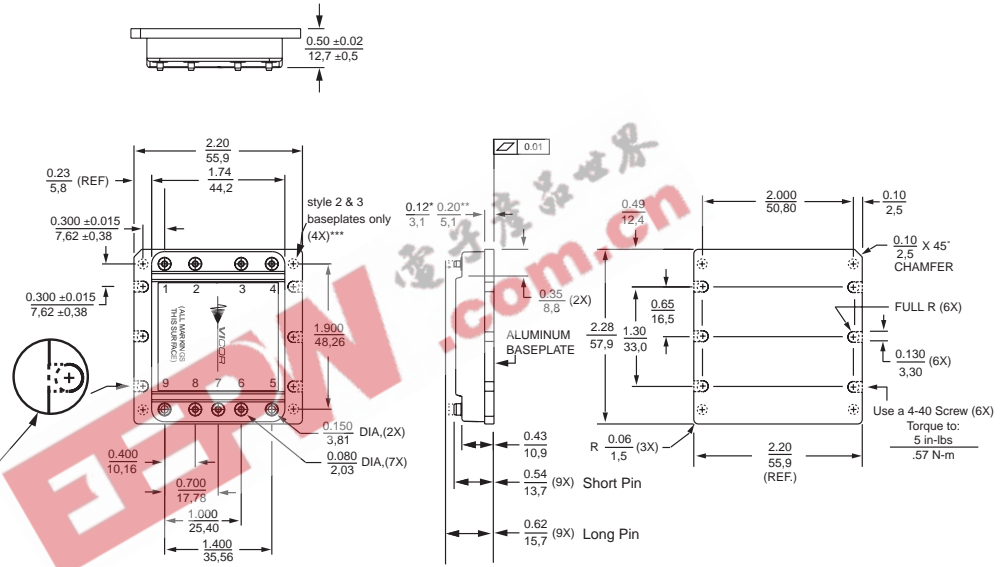

* Style 1 baseplate only
** Style 2 & 3 baseplates
*** Reserved for Vicor accessories
Not for mounting

PCB Mounting Specifications

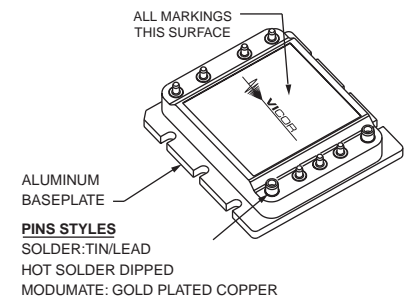
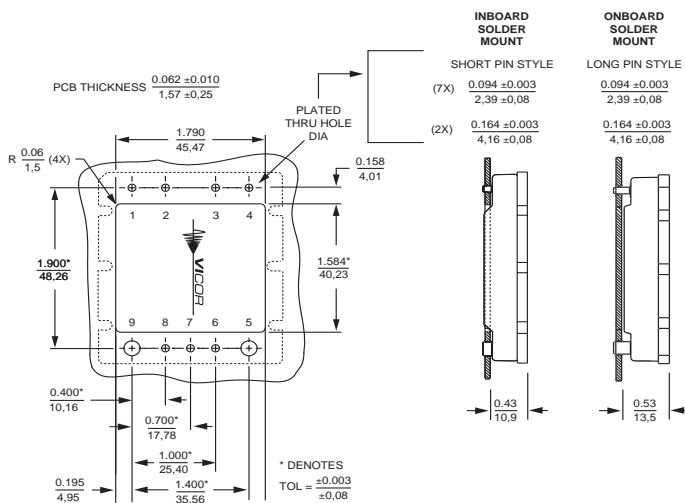

Vicor's comprehensive line of power solutions includes high density AC-DC and DC-DC modules and accessory components, fully configurable AC-DC and DC-DC power supplies, and complete custom power systems.

Information furnished by Vicor is believed to be accurate and reliable. However, no responsibility is assumed by Vicor for its use. Vicor components are not designed to be used in applications, such as life support systems, wherein a failure or malfunction could result in injury or death. All sales are subject to Vicor's Terms and Conditions of Sale, which are available upon request.

Specifications are subject to change without notice.



*Component Solutions
for Your Power System*

Vicor Corporation
25 Frontage Road
Andover, MA, USA 01810
Tel: 800-735-6200
978-470-2900
Fax: 978-475-6715

email

Vicor Express: vicorexp@vicr.com
Technical Support: apps@vicr.com