

DATA SHEET

EEPW 电子产品世界
.com.cn

74F3893

Quad futurebus backplane transceiver

Product specification

1991 Jan 18

IC15 Data Handbook

Quad Futurebus backplane transceiver

74F3893

FEATURES

- Quad backplane transceiver
- Drives heavily loaded backplanes with equivalent load impedances down to 10 ohms
- Futurebus drivers sink 100mA
- Reduced voltage swing (1 volt) produces less noise and reduces power consumption
- High speed operation enhances performance of backplane buses and facilitates incident wave switching
- Compatible with IEEE 896 and IEEE 1194.1 Futurebus Standards
- Built-in precision band-gap (BG) reference provides accurate receiver thresholds and improved noise immunity
- Glitch-free power up/power down operation on all outputs
- Pin and function compatible with NSC DS3893

DESCRIPTION

The 74F3893 is a quad backplane transceivers and is intended to be used in very high speed bus systems.

The 74F3893 interfaces to 'Backplane Transceiver Logic' (BTL). BTL features a reduced (1V to 2V) voltage swing for lower power consumption and a series diode on the drivers to reduce capacitive loading (< 5pF).

Incident wave switching is employed, therefore BTL propagation delays are short. Although the voltage swing is

much less for BTL, so is its receiver threshold region, therefore noise margins are excellent.

BTL offers low power consumption, low ground bounce, EMI and crosstalk, low capacitive loading, superior noise margin and low propagation delays. This results in a high bandwidth, reliable backplane.

The 74F3893 has four TTL outputs (R_n) on the receiver side with a common receiver enable input (\overline{RE}). It has four data inputs (D_n) which are also TTL. These data inputs are NANDed with the data enable input (DE). The four I/O pins (bus side) are futurebus compatible, sink a minimum of 100mA, and are designed to drive heavily loaded backplanes with load impedances as low as 10 ohms. All outputs are designed to be glitch-free during power up and down.

TYPE	TYPICAL PROPAGATION DELAY	TYPICAL SUPPLY CURRENT(TOTAL)
74F3893	3.0ns	55mA

ORDERING INFORMATION

DESCRIPTION	ORDER CODE	PKG DWG #
	COMMERCIAL RANGE $V_{CC} = 5V \pm 10\%$, $T_{amb} = 0^{\circ}C \text{ to } +70^{\circ}C$	
20-pin PLCC	N74F3893A	SOT380-1

INPUT AND OUTPUT LOADING AND FAN OUT TABLE

PINS	DESCRIPTION	74F (U.L.) HIGH/LOW	LOAD VALUE HIGH/LOW
D0 – D3	Data inputs	1.0/0.067	20 μ A/40 μ A
DE	Data enable input	1.0/0.33	20 μ A/200 μ A
\overline{RE}	Receiver enable input	1.0/0.067	20 μ A/40 μ A
I/O0 – I/O3	Bus inputs	5.0/0.033	100 μ A/20 μ A
I/O0 – I/O3	Bus outputs	OC/166.7	OC/100mA
R0 – R7	Receiver outputs	150/40	3mA/24mA

Notes to input and output loading and fan out table

One (1.0) FAST unit load is defined as: 20 μ A in the high state and 0.6mA in the low state.
OC= Open collector.

Quad Futurebus backplane transceiver

74F3893

PIN CONFIGURATION

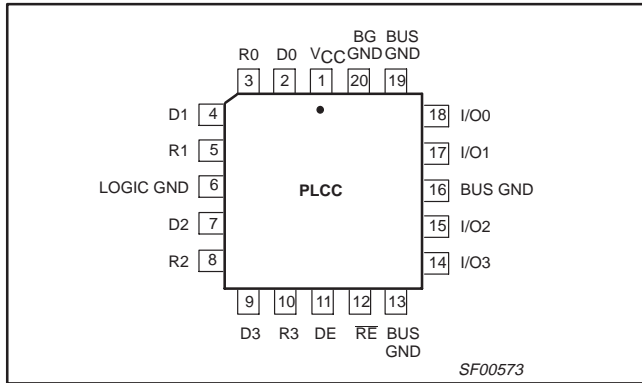

FUNCTION TABLE

INPUTS		INPUT/OUTPUT	OUTPUT	OPERATING MODE
DE	RE	Dn	I/On	
H	L	L	H	Transmit to bus
H	L	H	L	
H	H	Dn	$\bar{D}n$	Receiver 3-state, transmit to bus
L	H	X	H	
L	L	X	H	Receive, I/On = inputs
L	L	X	L	

Notes to function table

1. H = High voltage level
2. L = Low voltage level
3. X = Don't care
4. Z = High impedance "off" state

LOGIC SYMBOL

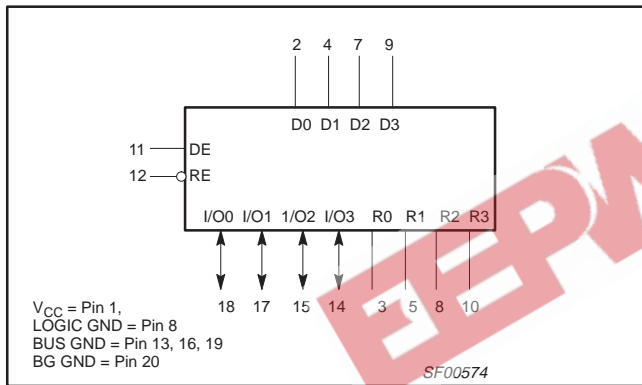

LOGIC DIAGRAM

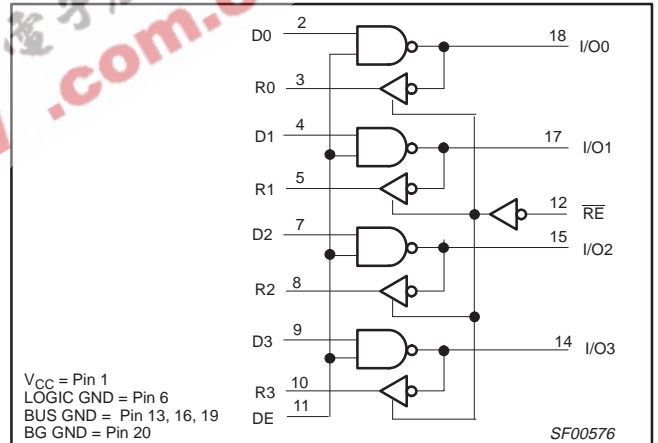

IEC/IEEE SYMBOL

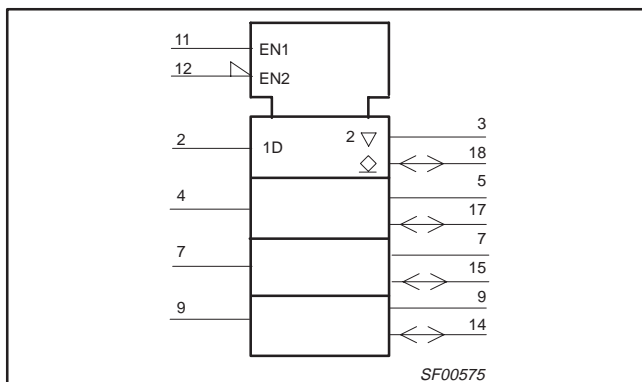

Quad Futurebus backplane transceiver

74F3893

ABSOLUTE MAXIMUM RATINGS

(Operation beyond the limit set forth in this table may impair the useful life of the device. Unless otherwise noted these limits are over the operating free air temperature range.)

SYMBOL	PARAMETER	RATING	UNIT
V _{CC}	Supply voltage	-1.5 to +6.5	V
V _{IN}	Input voltage	-1.5 to +6.5	V
I _{IN}	Input current	-30 to +5	mA
V _{OUT}	Voltage applied to output in high output state	-0.5 to 5.5	V
I _{OUT}	Current applied to output in low output state	200	mA
T _{amb}	Operating free air temperature range	0 to +70	°C
T _{stg}	Storage temperature range	-65 to +150	°C

RECOMMENDED OPERATING CONDITIONS

SYMBOL	PARAMETER	LIMITS			UNIT
		MIN	NOM	MAX	
V _{CC}	Supply voltage	4.5	5.0	5.5	V
V _{IH}	High-level input voltage	2.0			V
V _{IL}	Low-level input voltage			0.8	V
I _{Ik}	Input clamp current			-18	mA
V _{TH}	Bus input threshold	1.475	1.55	1.625	mV
I _{OH}	High-level output current			-3	mA
I _{OL}	Low-level output current			100	mA
T _{amb}	Operating free air temperature range	0		+70	°C

Quad Futurebus backplane transceiver

74F3893

DC ELECTRICAL CHARACTERISTICS

(Over recommended operating free-air temperature range unless otherwise noted.)

SYMBOL	PARAMETER		TEST CONDITIONS ¹	LIMITS			UNIT
				MIN	TYP ²	MAX	
I _{OH}	High-level output current	I/On	V _{CC} = MAX, V _{IL} = MAX, V _{IH} = MIN, V _{OH} = 1.5V		10	100	μA
V _{OH}	High-level output voltage	Rn	V _{CC} = MAX, V _{IL} = 1.3V, R _E = 0.8V, I _{OH} = MAX	2.5			V
V _{OHB}	High-level output bus voltage	I/On	V _{CC} = MAX, Dn = DE = 0.8V, V _T = 2.0V, R _T = 10Ω, R _E = 2.0V	2.5			V
V _{OL}	Low-level output voltage	Rn	V _{CC} = MIN, V _{IN} = 1.8V, R _E = 0.8V, I _{OL} = 6mA		0.35	0.5	V
V _{OLB}	Low-level output bus voltage	I/On	Dn = DE = V _{IH} , I _{OL} = 100mA	0.75	1.0	1.2	V
			Dn = DE = V _{IH} , I _{OL} = 80mA	0.75	1.0	1.1	V
V _{OCB}	Driver output positive clamp voltage	I/On	V _{CC} = MAX or 0V,	I/On = 1mA	1.9	2.9	V
			Dn = DE = 0.8V, R _E = 2.0V	I/On = 10mA	2.3	3.2	V
V _{IK}	Input clamp voltage		V _{CC} = MIN, I _I = I _{IK}		-0.73	-1.2	V
I _I	Input current at maximum input voltage		V _{CC} = MAX, V _I = 7.0V, DE = R _E = Dn = V _{CC}			100	μA
I _{IH}	High-level input current	Dn, R _E , DE	V _{CC} = MAX, DE = R _E = Dn = 5.5V			20	μA
I _{IHB}	High-level I/O bus current (power off)	I/On	V _{CC} = 0V, Dn = DE = 0.8V, I/On = 1.2V, R _E = 0V			100	μA
I _{IL}	Low-level input current	Dn, R _E	V _{CC} = MAX, V _I = 0.5V, DE = 4.5V			-40	μA
			DE	V _{CC} = MAX, V _I = 0.5V, Dn = 4.5V			-200
I _{ILB}	Low-level I/O bus current (power on)	I/On	V _{CC} = MAX, Dn = DE = 0.8V, I/On = 0.75V, R _E = 0V	-20		20	μA
I _{OZH}	Off-state output current, high-level voltage applied	Rn	V _{CC} = MAX, V _I = 2.7V, R _E = 2V			20	μA
I _{OZL}	Off-state output current, low-level voltage applied		V _{CC} = MAX, V _I = 0.5V, R _E = 2V			-20	μA
I _{OS}	Short circuit output current ³	Rn	V _{CC} = MAX	-60		-150	mA
I _{CC}	Supply current ⁴ (total)		V _{CC} = MAX, (R _E = V _{IH} or V _{IL})		55	80	mA

Notes to DC electrical characteristics

- For conditions shown as MIN or MAX, use the appropriate value specified under recommended operating conditions for the applicable type.
- All typical values are at V_{CC} = 5V, T_{amb} = 25°C.
- Not more than one output should be shorted at a time. For testing I_{OS}, the use of high-speed test apparatus and/or sample-and-hold techniques are preferable in order to minimize internal heating and more accurately reflect operational values. Otherwise, prolonged shorting of a high output may raise the chip temperature well above normal and thereby cause invalid readings in other parameter tests. In any sequence of parameter tests, I_{OS} tests should be performed last.

Quad Futurebus backplane transceiver

74F3893

AC ELECTRICAL CHARACTERISTICS FOR DRIVER AND DRIVER ENABLE

SYMBOL	PARAMETER	TEST CONDITION	LIMITS					UNIT
			T _{amb} = +25°C V _{CC} = +5.0V C _D = 50pF, R _T = 10Ω			T _{amb} = 0°C to +70°C V _{CC} = +5.0V ± 10% C _D = 50pF, R _T = 10Ω		
			MIN	TYP	MAX	MIN	MAX	
t _{PLH} t _{PHL}	Propagation delay Dn to I/On	Waveform 1	1.0 1.5	2.0 3.0	5.0 5.5	1.0 1.5	5.5 6.0	ns
t _{PLH} t _{PHL}	Propagation delay DE to I/On	Waveform 1	1.0 1.5	2.0 3.0	4.5 5.5	1.0 1.5	5.5 6.0	ns
t _{TLH} t _{THL}	Dn to I/O transition time 10% to 90%, 90% to 10%	Waveform 1	1.0 1.0		4.0 4.0	1.0 1.0	5.0 5.0	ns
t _{sk(o)}	Skew between drivers in same package			1.0				ns

AC ELECTRICAL CHARACTERISTICS FOR RECEIVER

SYMBOL	PARAMETER	TEST CONDITION	LIMITS					UNIT
			T _{amb} = +25°C V _{CC} = +5.0V C _L = 50pF, R _L = 1kΩ			T _{amb} = 0°C to +70°C V _{CC} = +5.0V ± 10% C _L = 50pF, R _L = 1kΩ		
			MIN	TYP	MAX	MIN	MAX	
t _{PLH} t _{PHL}	Propagation delay I/On to Rn	Waveform 2	1.0 3.6	2.0 5.5	4.5 7.5	1.0 3.6	5.5 8.5	ns

AC ELECTRICAL CHARACTERISTICS FOR RECEIVER ENABLE

SYMBOL	PARAMETER	TEST CONDITION	A PORT LIMITS					UNIT
			T _{amb} = +25°C V _{CC} = +5.0V C _L = 50pF, R _L = 500Ω			T _{amb} = 0°C to +70°C V _{CC} = +5.0V ± 10% C _L = 50pF, R _L = 500Ω		
			MIN	TYP	MAX	MIN	MAX	
t _{PZH} t _{PZL}	Output enable time to high or low level, RE to Rn	Waveform 3, 4	1.5 2.5	3.0 4.0	5.5 7.0	1.5 2.0	6.0 7.5	ns
t _{PHZ} t _{PLZ}	Output disable time from high or low level, RE to Rn	Waveform 3, 4	1.5 1.5	3.0 3.0	5.5 5.5	1.0 1.0	6.5 6.0	ns

Quad Futurebus backplane transceiver

74F3893

AC WAVEFORMS

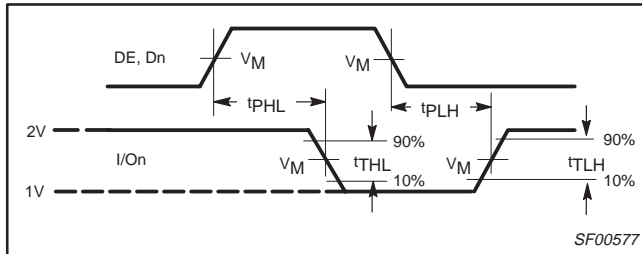

Waveform 1. Propagation delay for driver

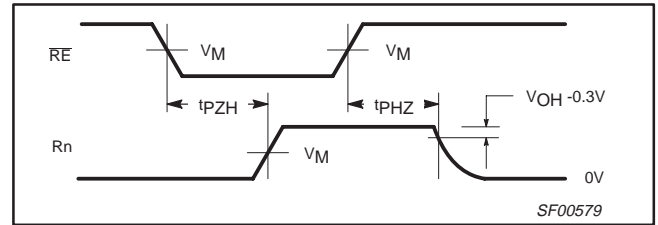

Waveform 3. 3-state output enable time to high level and output disable time from high level

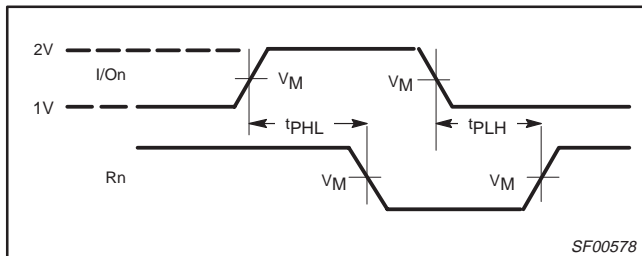

Waveform 2. Propagation delay for receiver

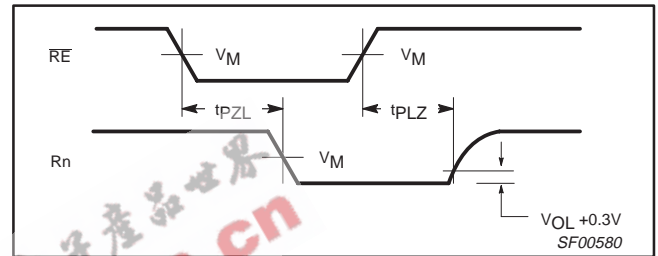

Waveform 4. 3-state output enable time to low level and output disable time from low level

Notes to AC waveforms

- For all waveforms, V_M = 1.5V.
- The shaded areas indicate when the input is permitted to change for predictable output performance.

TEST CIRCUITS AND WAVEFORMS

TEST	SWITCH
t _{PLZ} , t _{PZL}	closed
All other	open

Test circuit for 3-state outputs on D port

Test circuit for outputs on I/O port

Input pulse definition

family	INPUT PULSE REQUIREMENTS						
	amplitude	Low V	V _M	rep. rate	t _w	t _{TLH}	t _{THL}
D port	3.0V	0.0V	1.5V	1MHz	500ns	2.5ns	2.5ns
I/O port	2.0V	1.0V	1.5V	1MHz	500ns	4.0ns	4.0ns

DEFINITIONS:
 R_L = Load resistor; see AC electrical characteristics for value.
 C_L = Load capacitance includes jig and probe capacitance; see AC electrical characteristics for value.
 R_U = Pull up resistor; see AC Electrical Characteristics for value.
 C_D = Load capacitance includes jig and probe capacitance; see AC electrical characteristics for value.
 R_T = Termination resistance should be equal to Z_{OUT} of pulse generators.

SF00581

Quad futurebus backplane transceiver

74F3893

PLCC20: plastic leaded chip carrier; 20 leads

SOT380-1

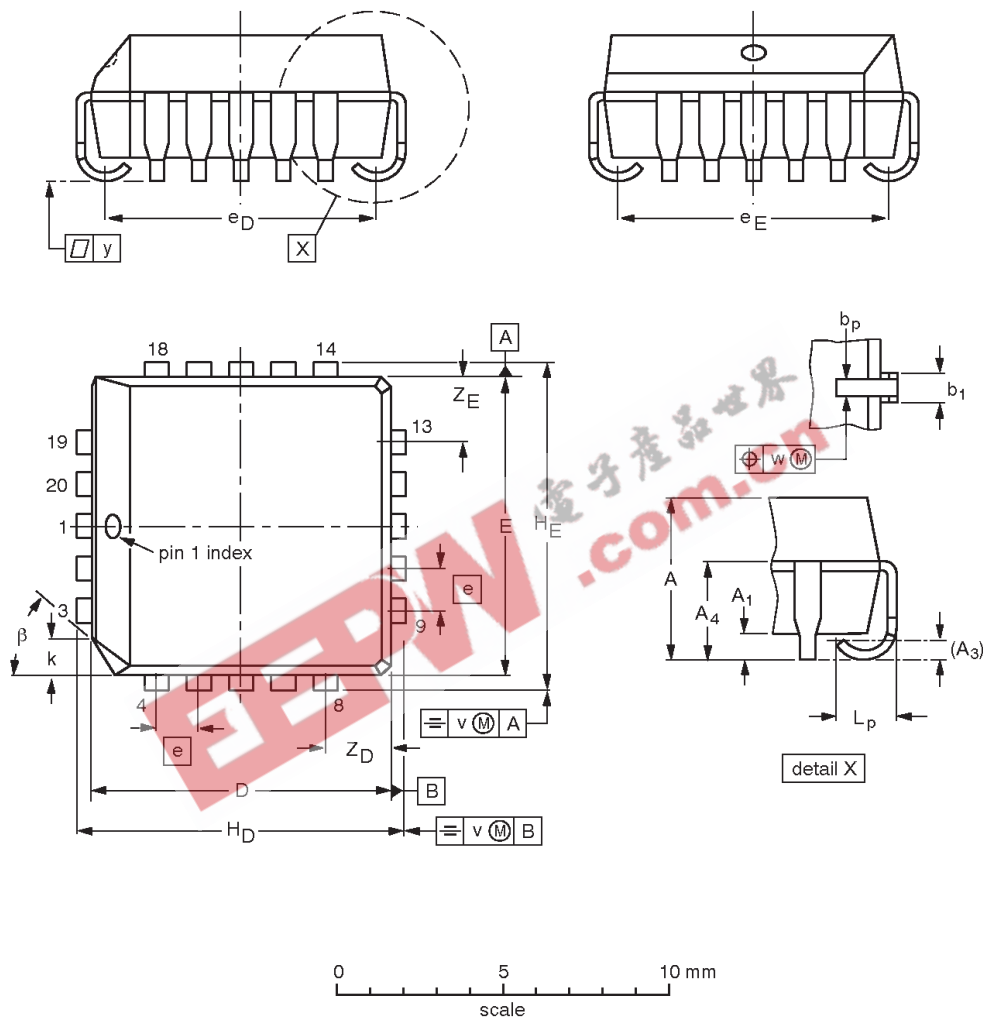

DIMENSIONS (millimetre dimensions are derived from the original inch dimensions)

UNIT	A	A ₁ min.	A ₃	A ₄ max.	b _p	b ₁	D ⁽¹⁾	E ⁽¹⁾	e	e _D	e _E	H _D	H _E	k	L _p	v	w	y	Z _D ⁽¹⁾ max.	Z _E ⁽¹⁾ max.	β
mm	4.57 4.19	0.51	0.25	3.05	0.53 0.33	0.81 0.66	9.04 8.89	9.04 8.89	1.27	8.38 7.37	8.38 7.37	10.03 9.78	10.03 9.78	1.22 1.07	1.44 1.02	0.18	0.18	0.10	2.16	2.16	45°
inches	0.180 0.165	0.020	0.01	0.12	0.021 0.013	0.032 0.026	0.356 0.350	0.356 0.350	0.05	0.330 0.290	0.330 0.290	0.395 0.385	0.395 0.385	0.048 0.042	0.057 0.040	0.007	0.007	0.004	0.085	0.085	

Note

1. Plastic or metal protrusions of 0.01 inches maximum per side are not included.

OUTLINE VERSION	REFERENCES				EUROPEAN PROJECTION	ISSUE DATE
	IEC	JEDEC	EIAJ			
SOT380-1		MO-047AA				95-02-25 97-12-16

Quad futurebus backplane transceiver

74F3893

NOTES



Quad futurebus backplane transceiver

74F3893

Data sheet status

Data sheet status	Product status	Definition [1]
Objective specification	Development	This data sheet contains the design target or goal specifications for product development. Specification may change in any manner without notice.
Preliminary specification	Qualification	This data sheet contains preliminary data, and supplementary data will be published at a later date. Philips Semiconductors reserves the right to make changes at any time without notice in order to improve design and supply the best possible product.
Product specification	Production	This data sheet contains final specifications. Philips Semiconductors reserves the right to make changes at any time without notice in order to improve design and supply the best possible product.

[1] Please consult the most recently issued datasheet before initiating or completing a design.

Definitions

Short-form specification — The data in a short-form specification is extracted from a full data sheet with the same type number and title. For detailed information see the relevant data sheet or data handbook.

Limiting values definition — Limiting values given are in accordance with the Absolute Maximum Rating System (IEC 134). Stress above one or more of the limiting values may cause permanent damage to the device. These are stress ratings only and operation of the device at these or at any other conditions above those given in the Characteristics sections of the specification is not implied. Exposure to limiting values for extended periods may affect device reliability.

Application information — Applications that are described herein for any of these products are for illustrative purposes only. Philips Semiconductors make no representation or warranty that such applications will be suitable for the specified use without further testing or modification.

Disclaimers

Life support — These products are not designed for use in life support appliances, devices or systems where malfunction of these products can reasonably be expected to result in personal injury. Philips Semiconductors customers using or selling these products for use in such applications do so at their own risk and agree to fully indemnify Philips Semiconductors for any damages resulting from such application.

Right to make changes — Philips Semiconductors reserves the right to make changes, without notice, in the products, including circuits, standard cells, and/or software, described or contained herein in order to improve design and/or performance. Philips Semiconductors assumes no responsibility or liability for the use of any of these products, conveys no license or title under any patent, copyright, or mask work right to these products, and makes no representations or warranties that these products are free from patent, copyright, or mask work right infringement, unless otherwise specified.

Philips Semiconductors
811 East Arques Avenue
P.O. Box 3409
Sunnyvale, California 94088-3409
Telephone 800-234-7381

© Copyright Philips Electronics North America Corporation 1998
All rights reserved. Printed in U.S.A.

print code

Date of release: 10-98

Document order number:

9397-750-05206

Let's make things better.