

FAST DMOS FET Switches

N-Channel Enhancement-Mode



SST211 / SST213 / SST215

FEATURES

- High Speed Switching..... $t_{d(ON)}$ 1ns
- Low Capacitance..... 2.4pF typical
- Low ON Resistance..... 50Ω typical
- High Gain
- Surface Mount Package

APPLICATIONS

- Ultra High Speed Analog Switching
- Sample and Hold
- Multiplexers
- High Gain Amplifiers

DESCRIPTION

Designed for audio, video and high frequency applications, the SST211 Series is a high speed, ultra low capacitance SPST analog switch. Utilizing Calogic's proprietary DMOS processing the SST211 Series features an integrated zener diode designed to protect the gate from electrical over stress.

ORDERING INFORMATION

Part	Package	Temperature Range
SST211	SOT-143 Surface Mount	-55°C to +125°C
SST213	SOT-143 Surface Mount	-55°C to +125°C
SST215	SOT-143 Surface Mount	-55°C to +125°C
XSST211	Sorted Chips in Carriers	-55°C to +125°C
XSST213	Sorted Chips in Carriers	-55°C to +125°C
XSST215	Sorted Chips in Carriers	-55°C to +125°C

PIN CONFIGURATION

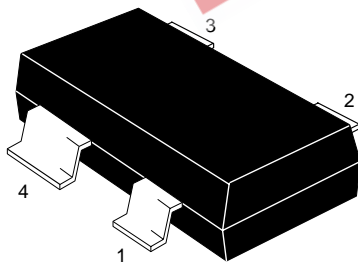

CD1-1

PRODUCT MARKING

SST211	211
SST213	213
SST215	215

SCHEMATIC DIAGRAM

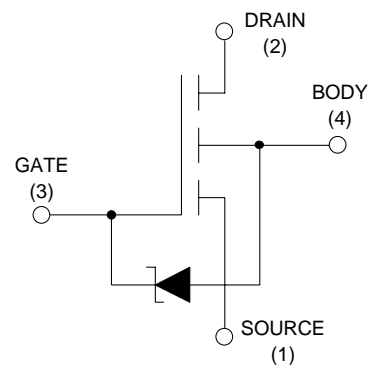



SST211 / SST213 / SST215

ABSOLUTE MAXIMUM RATINGS (T_c = +25°C unless otherwise noted)

Parameter	SST211	SST213	SST215	Unit
Breakdown Voltages				
V _{DS}	+30	+10	+20	V
V _{SD}	+10	+10	+20	V
V _{DB}	+30	+15	+25	V
V _{SB}	+15	+15	+25	V
V _{GS}	-15	-15	-25	V
V _{GB}	+25	+25	+30	V
V _{GD}	-0.3	-0.3	-0.3	V
	+25	+25	+30	V
	-30	-15	-25	V
	+25	+25	+30	V

I_D Continuous Drain Current 50mA
 P_T Power Dissipation (at or below T_c = +25°C) 360mW
 Linear Derating Factor 3.6mW/°C
 T_j Operating Junction Temperature Range . . -55 to +125°C
 T_s Storage Temperature Range -55 to +150°C

ELECTRICAL CHARACTERISTICS (T_c = +25°C unless otherwise noted)

SYMBOL	CHARACTERISTICS	SST211			SST213			SST215			UNIT	TEST CONDITIONS
		MIN	TYP	MAX	MIN	TYP	MAX	MIN	TYP	MAX		
STATIC												
B _{VDS}	Drain-Source Breakdown Voltage	30	35								V	I _D = 10μA, V _{GS} = V _{BS} = 0
		10	25		10	25		20	25			I _D = 10nA, V _{GS} = V _{BS} = -5V
B _{VSD}	Source-Drain Breakdown Voltage	10			10			20				I _S = 10nA, V _{GD} = V _{BD} = -5V
B _{VDB}	Drain-Body Breakdown Voltage	15			15			25				I _D = 10nA, V _{GB} = 0 Source OPEN
B _{VSB}	Source-Body Breakdown Voltage	15			15			25				I _S = 10μA, V _{GB} = 0 Drain OPEN
I _{D(OFF)}	Drain-Source OFF Current		0.2	10		0.2	10				nA	V _{DS} = 10V
									0.2	10		V _{GS} = V _{BS} = -5V
I _{S(OFF)}	Source-Drain OFF Current		0.6	10		0.6	10				nA	V _{SD} = 10V
									0.6	10		V _{GD} = V _{BD} = -5V
I _{GBS}	Gate-Body Leakage Current			10			10				μA	V _{GB} = 25V
										10		V _{DB} = V _{SB} = 0
V _{GS(th)}	Gate Threshold Voltage	0.5	1.0	2.0	0.1		2.0	0.1	1.0	2.0	V	V _{DS} = V _{GS} , I _D = 1μA, V _{SB} = 0
r _{ds(on)}	Drain-Source ¹ ON Resistance		50	70		50	70		50	70	ohms	V _{GS} = 5V
			30	45		30	45		30	45		V _{GS} = 10V
DYNAMIC												
g _{fs}	Common-Source ¹ Forward Transcond.	10	12		10	12		10	12		mS	V _{DS} = 10V, I _D = 20mA f = 1KHz, V _{SB} = 0
C _(gs + gd + gb)	Gate Node Capacitance		2.4	3.5		2.4	3.5		2.4	3.5	pF	V _{DS} = 10V V _{GS} = V _{BS} = -15V f = 1MHz
C _(gd + db)	Drain Node Capacitance		1.3	1.5		1.3	1.5		1.3	1.5		
C _(gs + sb)	Source Node Capacitance		3.5	4.0		3.5	4.0		3.5	4.0		
C _(dg)	Reverse Transfer Capacitance		0.3	0.5		0.3	0.5		0.3	0.5		
t _{d(ON)}	Turn ON Delay Time		0.7	1.0		0.7	1.0		0.7	1.0	ns	V _{DD} = 5V, V _{G(ON)} = 10V R _L = 680, R _G = 51
t _r	Rise Time		0.8	1.0		0.8	1.0		0.8	1.0		
t _(OFF)	Turn OFF Time		10			10			10			

NOTE 1: Pulse Test, 80 Sec, 1% Duty Cycle
 Typical Performance Characteristics: See SD211-215 Series